

(No Model.)

H. H. SANNER.
AUTOMATIC FIRE KINDLER.

No. 522,353.

Patented July 3, 1894.

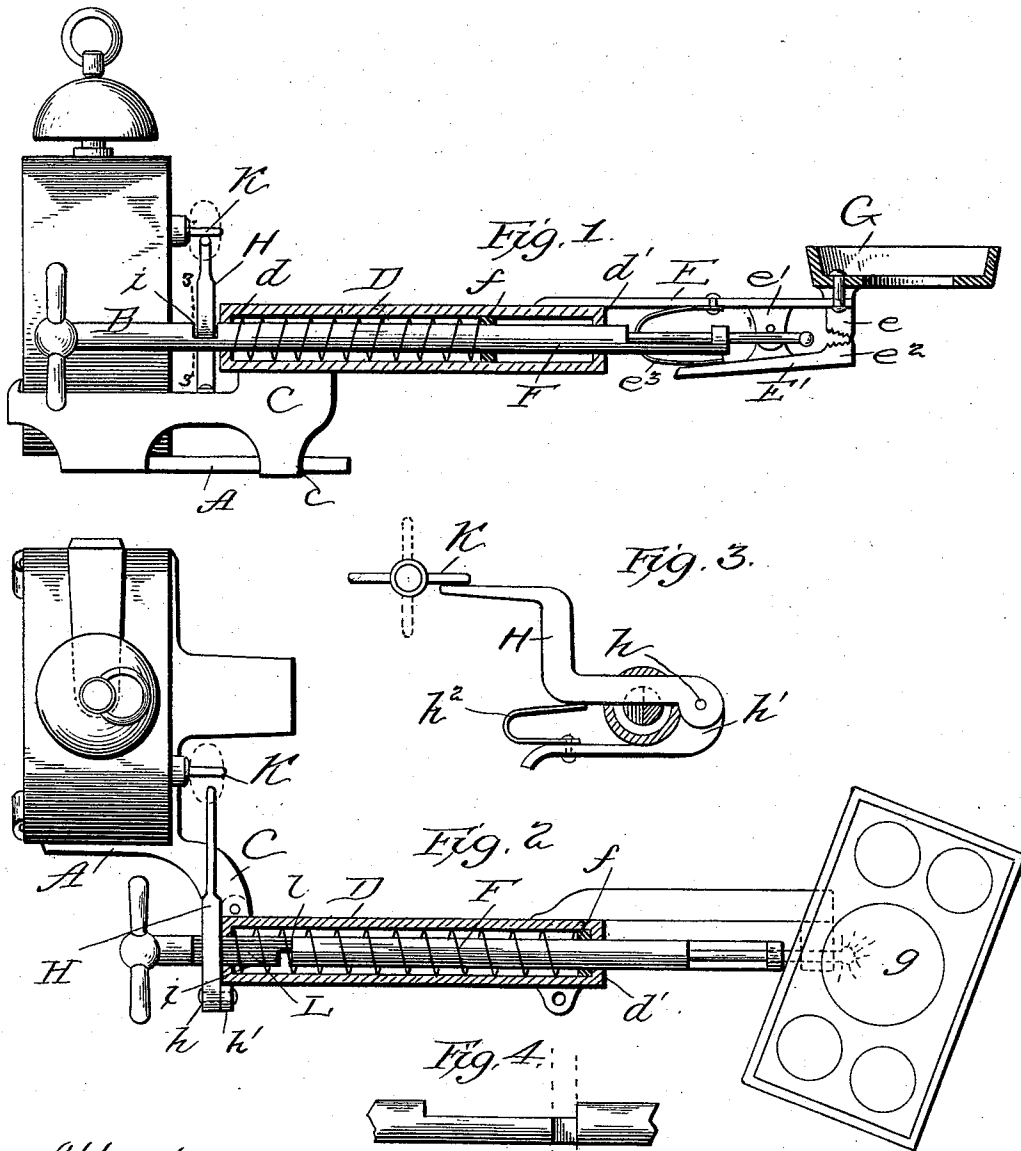

Attest
Walter Maedson
F. L. Maddison

Inventor
Henry H. Sanner
by Ellis Spear
Att'y.

UNITED STATES PATENT OFFICE.

HENRY H. SANNER, OF QUINCY, ILLINOIS, ASSIGNOR OF ONE-HALF TO
JOHN J. FISHER, OF SAME PLACE.

AUTOMATIC FIRE-KINDLER.

SPECIFICATION forming part of Letters Patent No. 522,353, dated July 3, 1894.

Application filed August 4, 1893. Serial No. 482,380. (No model.)

To all whom it may concern:

Be it known that I, HENRY H. SANNER, a citizen of the United States of America, residing at Quincy, in the county of Adams and State of Illinois, have invented certain new and useful Improvements in Automatic Lighting Devices, of which the following is a specification.

The invention above referred to relates to devices for automatically igniting a fire at a predetermined time, and the objects of the invention are to simplify the construction and increase the effectiveness of the device.

A fire lighter constructed in accordance with my invention is illustrated in the accompanying drawings, in which—

Figure 1, is a longitudinal section through the lighting device, showing different positions assumed by some of the parts in dotted lines. Fig. 2, is a plan view. Fig. 3, is a section on line 3—3 of Fig. 1, showing the rear of the clock for releasing the parts in elevation. Fig. 4, is a detail view.

Referring more particularly to the drawings A represents a frame or plate of metal which is designed to rest upon or be secured to the hearth of a stove in any suitable or desired manner. This plate is adapted to have an ordinary alarm clock mounted upon it, as shown at B, which is preferably securely connected to it so as to be firmly held thereon. A projection or extension C is located on one side of the plate and to this extension is connected a hollow arm or casing D which has an extension E projecting beneath the grate of the stove (not shown). The hollow arm or casing may be formed integral with the extension from the plate A, or it may be connected thereto by a rivet *c* as shown in the present instance.

Within the hollow arm or casing is located a reciprocating plunger F of less size than the interior diameter of the casing, thus forming an annular space within which is located a helical spring which bears at one end against the contracted end *d*, by which the plunger is guided, and at the other against a shoulder *f* on the plunger, and tends to keep the plunger forced normally to the right. The forward portion of the plunger is guided in the contracted portion *d'*.

The extension E which extends beneath the grate is set slightly to one side of the casing D so as not to interfere with the plunger and it carries upon its extreme end a pan or receptacle G which is secured by one edge and has an open bottom as shown at *g*. The forward end of the plunger is fitted to receive a match, and when the plunger is pressed forward by the spring the head of the match will be directly beneath the open bottom of the pan and in position to ignite whatever combustible material may have been placed thereon. The plunger is held back against the pressure of the spring and released by the alarm clock by means of a construction which will be hereinafter described, and when so released is driven forward to ignite the match and hold it beneath the plate.

In order to ignite the match as it is carried forward I have provided a lug or projection *e* depending from the portion E which has a beveled or inclined serrated face. An arm or lever E' is pivotally mounted upon a depending lug *e'* on one side of portion E and this lever carries a beveled serrated portion *e²* corresponding to the portion *e* and so arranged that when the portions *e* and *e²* are in contact a V shaped notch is provided with the open end of the V toward the plunger. The portion *e²* is normally held in contact with the portion *e* by means of a spring *e³* which is secured to the extension E and bears against the rear end of lever E'.

For retaining the plunger against the pressure of the spring a lever H is provided pivoted at *h* on the extension *h'* and this lever is forced normally upward away from the plunger by a spring *h²*, but when forced down into contact with the retracted plunger it engages with a notch or recess *i* in the plunger and thus holds it in its retracted position. When so depressed the free end of the lever extends directly under the wing of the clock key K when said key is in a horizontal position as shown in full lines Fig. 3, but when the key is in a vertical position as shown in dotted lines the lever is free to be forced upward by its spring and release the plunger.

I prefer to construct the plunger with a cut away portion as shown at L, thus forming a plane flat face at right angles to the notch,

and in setting the device the clock is wound up leaving the key in a horizontal position and the lever is depressed and its end held by the wing of the key with the portion of the lever adjacent the plunger in contact with the said flat face. The plunger is then drawn back until the shoulder *l* is in contact therewith when the plunger is given a quarter turn to cause the lever to engage the notch when the plunger will be held in its retracted position.

It will of course be understood that at the hour for which the alarm is set the key will be turned, releasing the lever and allowing the plunger to be driven forward forcing the head of the match between the inclined faces, and igniting the same, when it will be held beneath the igniting pan. It will be observed that the spring will cause the said faces to accommodate themselves to any size match head and will cause sufficient friction to ignite the match at all times.

Having thus described my invention, what I claim is—

1. An automatic lighter for stoves comprising a frame, jaws under spring tension connected thereto, a plunger under spring tension for holding a match in rear of said jaws, and mechanism for automatically releasing the plunger to force the match through said jaws beneath the fuel to be lighted, substantially as described.

2. In combination, the cylinder having a match carrying plunger therein under spring tension, an extension carried by said cylinder having a beveled serrated projection, a

lever under spring tension pivoted to said extension having a second serrated projection bearing against the first and forming a V shaped opening, means for holding the plunger retracted and means for automatically releasing it to force the match through said V shaped opening, substantially as described.

3. In an automatic lighting device, a frame, a plunger under spring tension adapted to carry the match, a spring lever pivoted in the frame adapted to engage the plunger when retracted and an alarm clock having its alarm key in one position directly above the end of the spring lever to act as a stop to limit its movement and moving out of the path of said lever when turned to a vertical position, substantially as described.

4. In an automatic lighting device, a frame, a match carrying plunger reciprocating therein under spring tension, a contact for igniting the match, an alarm clock mounted on the frame, a lever pivoted in the frame having its free end extending into proximity to the clock key and engaged and released thereby, said plunger having a cut away portion adapted to permit limited longitudinal movement, and a notch whereby the plunger when retracted may be turned to cause said notch to engage the lever, substantially as described.

In testimony whereof I affix my signature in presence of two witnesses.

HENRY H. SANNER.

Witnesses:

OLIVER C. GERRY, Jr.,
THOMAS E. BURNS.