

(No Model.)

2 Sheets—Sheet 1.

I. D. WRIGHT.
BOW FACING OAR.

No. 522,545.

Patented July 3, 1894.

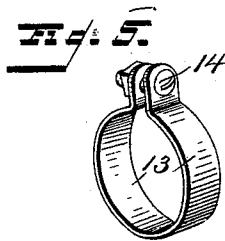
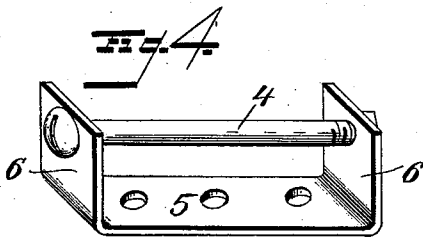
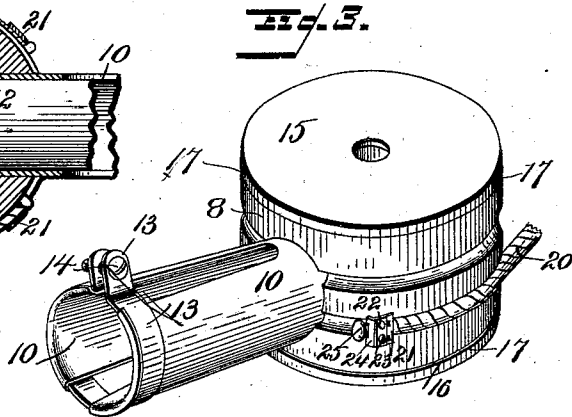
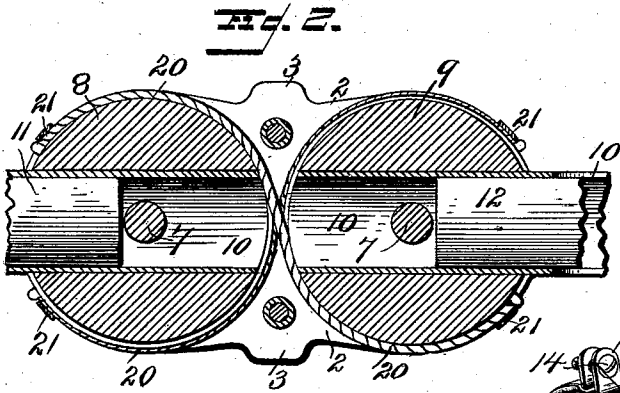
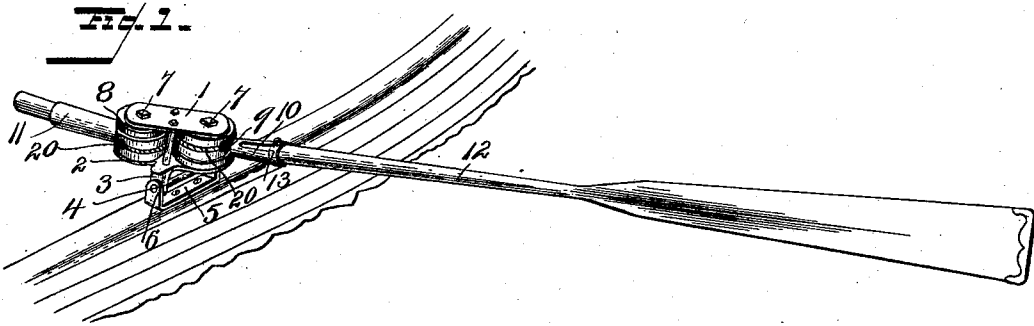

Witnesses
L. E. Hunt.
A. S. Shepard

Inventor
Isaac D. Wright
by *J. R. Little,*
Attorney

(No Model.)

2 Sheets—Sheet 2.

I. D. WRIGHT.
BOW FACING OAR.

No. 522,545.

Patented July 3, 1894.

Fig. 6.

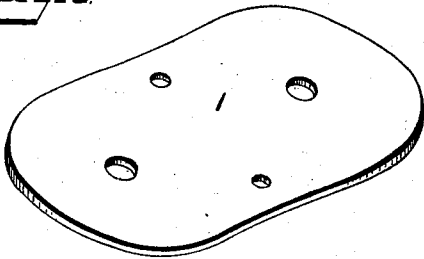

Fig. 7.

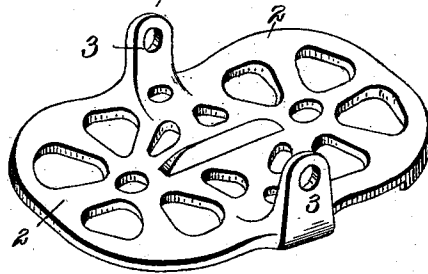

Fig. 8.

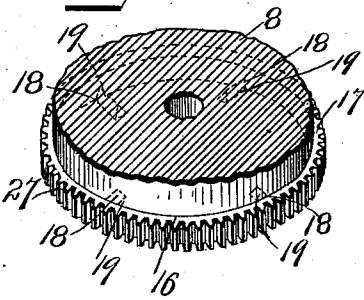

Fig. 9.

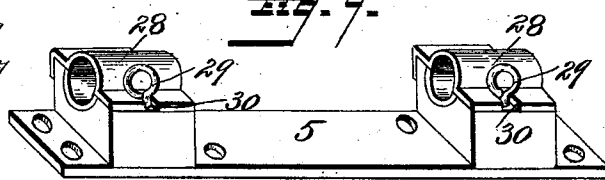
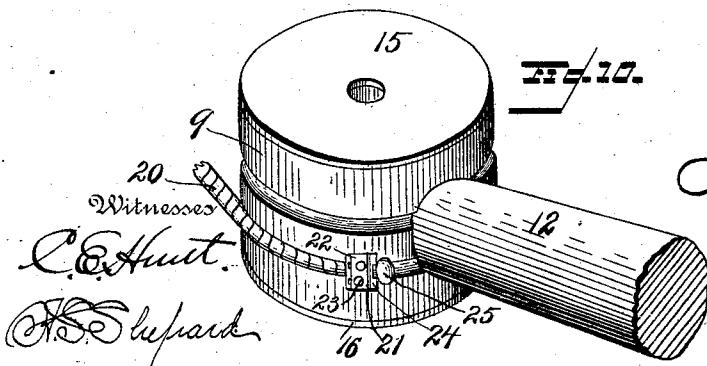

Fig. 10.



Witnesses
C. E. Hunt.
A. S. Shepard

Isaac D. Wright
Inventor
By *J. R. Little*
his Attorney

UNITED STATES PATENT OFFICE.

ISAAC D. WRIGHT, OF SEDALIA, MISSOURI.

BOW-FACING OAR.

SPECIFICATION forming part of Letters Patent No. 522,545, dated July 3, 1894.

Application filed June 6, 1893. Serial No. 476,779. (No model.)

To all whom it may concern:

Be it known that I, ISAAC D. WRIGHT, a citizen of the United States, residing at Sedalia, in the county of Pettis and State of Missouri, have invented certain new and useful Improvements in Bow-Facing Oars; and I do hereby declare that the following is a full, clear, and exact description of the invention, which will enable others skilled in the art to which it appertains to make and use the same.

My invention relates to bow-facing oars; and has for its object to provide improved, simple and efficient means for communicating a reverse motion from an oar-handle to the oar-blade, whereby the oarsman is enable to face in the direction of progress while applying power in the ordinary manner to the oar-handle, and also to provide means for folding the oar-handle and blade so as to lie within the line of the gunwale when the same are not in use.

Further objects and advantages of the invention will appear from the following description, and the novel features of my invention are embraced in the appended claims.

Referring to the accompanying drawings forming a part of this specification:—Figure 1 is a perspective view of a device embodying my invention, shown in operative position. Fig. 2 is a horizontal central sectional view of the motion-communicating devices. Fig. 3 is a detail view in perspective of one of the rotary heads within its attached ferrule, the upper and lower blades being shown detached. Fig. 4 is a similar view of the gunwale-strap and spindle. Fig. 5 is a similar view of the binding yoke for fastening the oar-handle and blade in the ferrules. Figs. 6 and 7 are similar views of the top and bottom connecting-plates, respectively, the latter being reversed to show the depending ears. Fig. 8 is a detail view of a lower cap-plate provided with peripheral teeth for communicating motion by intermeshing gears. Fig. 9 is a perspective view showing a gunwale-strap, journals, lower connecting-plate, and spindle, illustrating a different mode of attaching the device to the gunwale. Fig. 10 is a detail view of a modified form of head, showing the ferrule omitted and the oar inserted and secured in a socket in the said head. In this

view the flanges of the caps of the head are also omitted.

In all the views of the drawings, like numerals of reference indicate like or corresponding parts.

1 and 2 represent, respectively, the upper and lower connecting-plates, of which the latter is swiveled by suitable means to the gunwale of the boat, to permit of vertical movement of the oar, and is provided (in the arrangement shown in Figs. 1 and 7) with depending perforated ears, 3, which are mounted upon a spindle, 4, held in a position parallel to the gunwale by a gunwale-strap, 5, having up-turned perforated terminals, 6. These connecting plates carry vertical pivot-bolts, 7, upon which are secured rotatable heads, 8 and 9, having radially-disposed split ferrules, 10. In the ferrule which is carried by the head 8 is fitted the oar-handle, 11, and in the ferrule of the head 9 is fitted the shank of the oar-blade, 12. The oar-handle and blade are fixed securely in their respective ferrules by means of split yokes, 13, which embrace said ferrules near their outer ends and have their free extremities connected by adjusting bolts, 14.

The heads are cylindrical in shape, and upon their upper and lower ends may be fitted caps, 15 16, which are flanged, as shown at 17, (Fig. 3) and are provided with inwardly-extending pins, 18, to engage notches, 19, in the edges of the heads. In Fig. 10 the caps 15 16 are shown without flanges.

In the construction shown in Fig. 1, the heads are connected by flexible bands, 20, which are crossed intermediate the heads, and the extremities of which are connected, respectively, to opposite sides of the same by clips, 21. These clips are angular in shape, their body-portion, 22, being secured by means of screws, 23, to the bodies of the heads, and the upturned ends, 24, thereof are notched to receive the enlarged ends, 25, of the bands.

From the foregoing description it will be understood that a backward movement of the free end of the oar-handle will produce a similar or corresponding movement of the free end of the blade.

The connecting-plates may be provided with terminal segmental flanges, 26, to embrace the outer sides of the heads, as shown

at one end of the bottom plate in Fig. 7, but such flange may be omitted without materially affecting the operativeness or efficiency of the invention.

5 Fig. 8 shows a modified form of connection between the heads, in which the lower cap-plate is provided with peripheral teeth, 27, to mesh with a corresponding series of teeth upon the other cap-plate, thus constituting
10 another method of transmitting motion from the oar-carrying to the blade-carrying head.

In Fig. 9, I have shown a somewhat different form of the means for connecting the lower plate 2 to the gunwale, the same consisting of journals having hinged caps, 28, to
15 receive the ends of the spindle 4, such caps being held in position by rotatable headed pins, 29, engaging notches, 30, in the free ends of the caps.

20 Wire rope, metal straps, or chain may be employed as the material for forming the flexible motion-transmitting bands, as preferred.

The space or interval between the free
25 edges of the flanges upon the cap-plates forms a groove for the reception of the flexible bands to prevent vertical displacement thereof.

Lost motion or slack in bands may be com-
30 pensated for by the adjustment of the clips 21, which latter may be provided with slots or perforations for this purpose of taking up the slack.

In practice, I may, under some circum-
35 stances, modify the exact construction as herein illustrated and described, and it is obvious that numerous changes and variations may be made as mechanical expedients or equivalents. I therefore, reserve the right to make
40 all variations, changes, and departures as to form, proportion, and minor details of construction which come within the spirit and scope of my invention as defined and set forth in the appended claims.

45 Instead of employing a rotary head of metal

provided with a split ferrule and tightening yoke, I may use the form of head shown in Fig. 10, which consists of a hollow wooden drum having end caps flush with the side of the drum and devoid of overlapping flanges. 50 In this instance, it will also appear that I have dispensed with the oar-receiving ferrule, the oar being simply secured in socket or opening in the head and then fastened by screws or otherwise. 55

Having thus described my invention, what I claim and desire to secure by Letters Patent, is—

1. In a device of the class described, the combination, with oscillating heads provided
60 with means for the attachment of an oar-handle and blade respectively, and flexible connections between such heads, of clips, 21, for adjustably securing said flexible connections to the heads, said clips consisting each of the
65 body portion 22 and the notched upturned ends, substantially as set forth.

2. In a device of the class described, the combination of independent oscillating cylindrical heads, detachable flanged caps provided with inwardly extending pins to engage notches in the edges of said heads, means for connecting the oar-handle and blade to the said heads, and operating connections between the heads, substantially as set forth. 75

3. In a device of the class described, the combination, with the connecting plates 1 and 2, the heads 8 and 9 swiveled thereto, and the plate 2 having the perforated ears 3 depending therefrom, of the gunwale strap 5 having
80 upturned perforated terminals 6, and the spindle 4 carried thereby and upon which the connecting plates 1 and 2 are mounted by means of the ears 3, substantially as set forth.

In testimony whereof I affix my signature in
85 presence of two witnesses.

ISAAC D. WRIGHT.

Witnesses:

ALBERT E. MCCLURE,
CARLON C. VAN WAGNER.