



(51) International Patent Classification:

F02C 3/00 (2006.01) F02C 3/14 (2006.01)  
F02C 3/20 (2006.01) F02C 7/22 (2006.01)

(21) International Application Number:

PCT/US2013/038962

(22) International Filing Date:

30 April 2013 (30.04.2013)

(25) Filing Language:

English

(26) Publication Language:

English

(30) Priority Data:

61/640,692 30 April 2012 (30.04.2012) US

(71) Applicant: **CLEARSIGN COMBUSTION CORPORATION** [US/US]; 12870 Interurban Avenue South, Seattle, Washington 98168 (US).

(72) Inventors: **COLANNINO, Joseph**; 2836 78TH AVENUE SE #502, Mercer Island, Washington 98040 (US). **KRICHTAFOVICH, Igor A.**; 6827 117TH AVE NE,

Kirkland, Washington 98033 (US). **BREIDENTHAL, Robert E.**; 5722 NE 56TH STREET, Seattle, Washington 98105 (US). **WIKLOF, Christopher A.**; 3531 99TH STREET SE, Everett, Washington 98208 (US).

(74) Agents: **LAUNCHPAD INTELLECTUAL PROPERTY, INC.** et al.; 914 164th St., SE, Ste. B12 #433, Mill Creek, Washington 98012 (US).

(81) Designated States (unless otherwise indicated, for every kind of national protection available): AE, AG, AL, AM, AO, AT, AU, AZ, BA, BB, BG, BH, BN, BR, BW, BY, BZ, CA, CH, CL, CN, CO, CR, CU, CZ, DE, DK, DM, DO, DZ, EC, EE, EG, ES, FI, GB, GD, GE, GH, GM, GT, HN, HR, HU, ID, IL, IN, IS, JP, KE, KG, KM, KN, KP, KR, KZ, LA, LC, LK, LR, LS, LT, LU, LY, MA, MD, ME, MG, MK, MN, MW, MX, MY, MZ, NA, NG, NI, NO, NZ, OM, PA, PE, PG, PH, PL, PT, QA, RO, RS, RU, RW, SC, SD, SE, SG, SK, SL, SM, ST, SV, SY, TH, TJ, TM, TN, TR, TT, TZ, UA, UG, US, UZ, VC, VN, ZA, ZM, ZW.

[Continued on next page]

(54) Title: GAS TURBINE AND GAS TURBINE AFTERBURNER

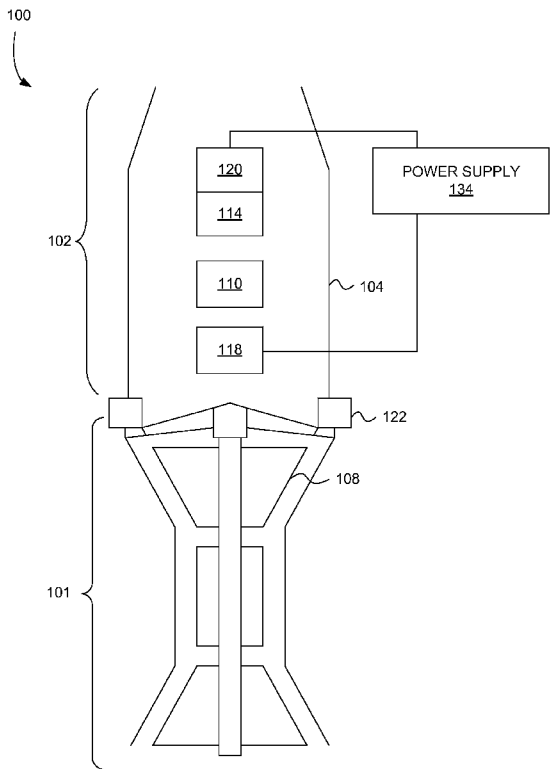

(57) Abstract: A gas turbine afterburner includes a gutter electrode that helps to hold an afterburner flame. A charge source applies a majority charge to be carried by a turbine exhaust gas. Electrical attraction between the majority charge and the gutter electrode helps to hold the afterburner flame.

WO 2013/166084 A1

- (84) Designated States** (*unless otherwise indicated, for every kind of regional protection available*): ARIPO (BW, GH, GM, KE, LR, LS, MW, MZ, NA, RW, SD, SL, SZ, TZ, UG, ZM, ZW), Eurasian (AM, AZ, BY, KG, KZ, RU, TJ, TM), European (AL, AT, BE, BG, CH, CY, CZ, DE, DK, EE, ES, FI, FR, GB, GR, HR, HU, IE, IS, IT, LT, LU, LV, MC, MK, MT, NL, NO, PL, PT, RO, RS, SE, SI, SK, SM, TR), OAPI (BF, BJ, CF, CG, CI, CM, GA, GN, GQ, GW, ML, MR, NE, SN, TD, TG).
- Published:**
- *with international search report (Art. 21(3))*
  - *before the expiration of the time limit for amending the claims and to be republished in the event of receipt of amendments (Rule 48.2(h))*

# **GAS TURBINE AND GAS TURBINE AFTERBURNER**

5

## **CROSS-REFERENCE TO RELATED APPLICATIONS**

The present application claims priority benefit from U.S. Provisional Patent Application No. 61/640,692, entitled "HIGH VELOCITY COMBUSTOR", filed April 10 30, 2012, which to the extent not inconsistent with the disclosure herein, is incorporated by reference.

## **BACKGROUND**

15 In gas turbine engines, an afterburner can be added to support an increase thrust for short periods. Afterburners are also referred to as "reheat systems" in the literature. Afterburners work by spraying fuel into hot exhaust gas exiting the final turbine stage of a gas turbine. The sprayed fuel is ignited to react with residual oxygen present in the exhaust gas from the final turbine stage. 20 While afterburners are inefficient with respect to fuel consumption, they can increase thrust dramatically and are especially useful for increasing thrust at take-off or transonic transition (between about Mach 0.95 and Mach 1.2 to 1.7, for example). Afterburners can be particularly useful in military aircraft.

Afterburners use flame holders, also referred to as gutters, to hold the 25 afterburner flame and prevent flame blow-out. Afterburner gutters in the prior art operate as bluff bodies that cause heat recycling into the fuel spray by the formation vortices formed on the trailing edge of the gutter.

## SUMMARY

5 An afterburner with reduced gutter size would be useful for decreasing aerodynamic drag and thereby increasing thrust produced by the afterburner or reducing fuel consumed by the afterburner.

According to an embodiment, a gas turbine afterburner includes a gutter configured as an aerodynamic bluff body to produce vortices in exhaust gas from the gas turbine, a charge source configured to apply a majority charge to the exhaust gas or the fuel, and a gutter electrode configured to attract the majority charge toward the gutter. By augmenting flame holding with the electrical attraction between the exhaust gas and the gutter electrode, the vortices can be formed to cause less parasitic pressure drop through the afterburner.

According to an embodiment, a method for operating a gas turbine afterburner includes applying a majority electrical charge to be carried by a hot exhaust gas, applying a holding voltage to a gutter electrode, and holding a flame in a gas turbine exhaust pipe with a combination of an aerodynamic gutter and an attractive force between the holding voltage applied to the gutter electrode and the majority charge carried by the hot exhaust gas.

20

## BRIEF DESCRIPTION OF THE DRAWINGS

25 **FIG. 1A** is a block diagram of a gas turbine with afterburner, according to an embodiment.

**FIG. 1B** is a combination perspective and block diagram view of the afterburner of **FIG. 1A**, according to an embodiment.

**FIG. 2** is a sectional diagram of a portion of the afterburner of **FIGS. 1A and 1B**, according to an embodiment.

30

**FIG. 3** is a diagram of the afterburner wherein the charge source includes a dielectric tube aligned to convey charged air into the exhaust gas, according to an embodiment.

**FIG. 4** is a diagram of the gas turbine with afterburner of **FIGS. 1B and 1C** wherein the gutter and gutter electrode are formed integrally with one another, according to an embodiment.

**FIG. 5** is a flow chart showing a method for using the gas turbine with afterburner, according to an embodiment.

10

## DETAILED DESCRIPTION

In the following detailed description, reference is made to the accompanying drawings, which form a part hereof. In the drawings, similar symbols typically identify similar components, unless context dictates otherwise. Other embodiments may be used and/or other changes may be made without departing from the spirit or scope of the disclosure.

**FIG. 1A** is a block diagram of a gas turbine 100 including a turbine portion 101 and an afterburner 102, according to an embodiment. **FIG. 1B** is a perspective view of the afterburner 102 of **FIG. 1A**, according to an embodiment. **FIG. 2** is a side sectional diagram of a portion of the afterburner 102 of **FIGS. 1A and 1B**, according to an embodiment 200. Referring to **FIGS 1A, 1B, and 2**, a gas turbine 100 includes an afterburner 102 with an exhaust pipe 104 aligned to receive exhaust gas from a gas turbine stage 108. A fuel sprayer 110 is configured to spray fuel 112 into the exhaust gas. A gutter 114 is configured as an aerodynamic bluff body to produce vortices in the exhaust gas help in holding an afterburner flame 106. Compared to the prior art, the gutter 114 may be made to have a smaller frontal area and/or smaller in aerodynamic drag because the vortices are aided by electrical attraction between charged particles carried in the exhaust gas and a gutter electrode 120 to hold the afterburner flame 106.

**SUBSTITUTE SHEET IN CLEAN COPY**

According to embodiments, a charge source 118 is configured to apply a majority charge to the exhaust gas or the fuel 112. For example, as shown in FIG. 2, the charge source can include a plurality of sharp projections forming a corona electrode in a portion of the fuel sprayer 110. A gutter electrode 120 is  
5 configured to attract the majority charge toward the gutter 114. The gutter 114 and the gutter electrode 120 can be electrically isolated from one another. An electrical isolation flange 122 can be configured to electrically insulate the exhaust pipe 104 from the gas turbine stage 108. Additionally or alternatively, the exhaust pipe 104 can be at least partially formed from a dielectric material. A  
10 fuel isolator 124 can be configured to electrically insulate the fuel sprayer 110 from the gas turbine 100.

A plurality of mounting rods 126 can be configured to support the fuel sprayer 110 and the gutter 114 from a turbine hub 128. Alternatively, the fuel sprayer 110 and the gutter 114 can be supported from the exhaust pipe 104.  
15 One or more mounting rod electrical insulators can be configured to electrically insulate the mounting rods 126 from the turbine hub 128. Additionally, one or more mounting rod electrical insulators 130 can be configured to electrically insulate the fuel sprayer 110, the gutter 114, and the charge source 118 from the mounting rods 126 and the turbine hub 128. The charge source 118 can take  
20 various forms.

The charge source 118 can include a high voltage wire configured to contact the sprayed fuel 112. An anvil 132 can be included and configured to deflect the sprayed fuel 112.

According to an embodiment, the anvil 132 can be configured to deflect  
25 the sprayed fuel 112. The charge source 118 and the anvil 132 can be combined. Additionally or alternatively, the charge source 118 and the anvil 132 can be formed contiguously.

FIG. 3 is a diagram of an embodiment 300 of the gas turbine with afterburner 102 of FIGS. 1A and 1B wherein the charge source 118 includes a  
30 dielectric tube 302 aligned to convey charged air into the exhaust gas, according to an embodiment.

**SUBSTITUTE SHEET IN CLEAN COPY**

Referring to FIGS. 1-4, a power supply 134 can be included and configured to apply a high voltage to the charge source 118. The power supply 134 can be configured to output a voltage selected to cause plasma emissions to form along a portion of the fuel 112 and the exhaust gas 106 to the gutter electrode 120. The plasma emissions may continuously ignite an afterburner flame. Additionally or alternatively, the power supply 134 can be configured to output a voltage selected to cause a luminous emission along a portion of the fuel 112 and the exhaust gas 106 to the gutter electrode 120. The luminous emission may be associated with ignition of the exothermic reaction.

5 The power supply 134 can be configured to apply a voltage to the exhaust gas 106 to cause the gutter 114 to hold an afterburner flame in an exhaust gas stream 106 having a velocity greater than the flame propagation velocity along the exhaust gas stream 106 absent the gutter electrode 120.

The power supply 134 can be configured to apply an alternating current voltage and/or a time-varying voltage to the charge source 118. The time-varying voltage can include a periodic voltage waveform having a 50 to 10,000 Hertz frequency. According to another embodiment, the time-varying voltage can include a periodic voltage waveform having a 200 to 800 Hertz frequency. The time-varying voltage can include a square waveform, sine waveform, triangular waveform, truncated triangular waveform, sawtooth waveform, logarithmic waveform, and/or exponential waveform. The time-varying voltage can include a waveform having  $\pm 1000$  volt to  $\pm 115,000$  volt amplitude. According to another embodiment, the time-varying voltage can include a waveform having  $\pm 8000$  volt to  $\pm 40,000$  volt amplitude.

25 The power supply 134 can be configured to hold the gutter electrode 120 at a voltage different than the voltage applied to the charge source 118. The voltage source can be configured to apply a second time-varying voltage to the gutter electrode 120, the second time-varying voltage being opposite in sign to the time-varying voltage applied to the charge source 118.

30 The power supply 134 can be configured to hold the gutter electrode 120 substantially at voltage ground and/or can be at a voltage opposite in polarity to

**SUBSTITUTE SHEET IN CLEAN COPY**

the voltage applied to the charge source 118. The gutter electrode 120 can be electrically isolated from ground and from voltages other than the voltage applied to the gutter electrode 120.

5 A flame detector may be included and configured to detect a presence of an afterburner flame by measuring a presence of the majority charge in a volume occupied by the afterburner flame. Additionally or alternatively, the flame detector can be configured to detect an absence of an afterburner flame by measuring an absence of the majority charge in a volume that would be occupied by the afterburner flame.

10 The charge source 118 and the gutter electrode 120 can be configured to cooperate to produce an ignition arc selected to maintain ignition of an afterburner flame.

15 **FIG. 4** shows an embodiment wherein the gutter 114 is formed from a dielectric material and the gutter electrode 120 is plated on a vacuum side of the gutter.

**FIG. 5** is a flow chart showing a method 500 for using the gas turbine 100 with afterburner 102, according to an embodiment. In step 502 a majority electrical charge may be applied to be carried by a hot exhaust gas. The majority charge may be applied to a combustion reaction in a combustor.

20

In other words, the majority charge can be applied to a combustion reaction prior to flowing the combustion reaction toward a first stage of the gas turbine.

25 The majority electrical charge may be applied to the hot exhaust gas at a gas flow node arranged to receive the hot exhaust gas from the gas turbine. The majority electrical charge may be applied to the fuel, and /or may be applied to the exhaust gas. The majority charge may be applied in an exhaust pipe 104 aligned to receive exhaust gas 106 from a gas turbine stage 108.

30 In step 502 the charge source can include a high voltage wire contacting the sprayed fuel and/or an anvil that deflects the sprayed fuel. Step 502 can

**SUBSTITUTE SHEET IN CLEAN COPY**

include flowing a charged fluid through a dielectric tube 202 aligned to convey the charged fluid into the exhaust gas.

Proceeding to step 504, the hot exhaust gas can be received from a gas turbine. Step 504 may include passing the hot combustion gas through at least one gas turbine stage and/or can include receiving the hot exhaust gas from the last stage of the turbine.

In step 506, fuel may be sprayed into the hot exhaust gas. Continuing to step 508, the fuel may be ignited to form a flame.

Proceeding to step 510, a holding voltage may be applied to a gutter electrode. In step 510, a voltage can be maintained to produce an ignition arc selected to maintain ignition of an afterburner flame between the hot exhaust gas majority charge and the gutter electrode.

In step 512 the flame may be held in a gas turbine exhaust pipe with a combination of an aerodynamic gutter and an attractive force between the holding voltage applied to the gutter electrode and a majority charge carried by the hot exhaust gas. Step 512 may include producing vortices with an aerodynamic bluff body and attracting the majority charge toward the gutter with a gutter electrode. Step 512 may include a cooperation between an aerodynamic gutter and a gutter electrode that are in electrical continuity with one another. The gutter electrode can include a conductive surface. The conductive surface can be electrically insulated and/or electrically isolated in intermittent electrical continuity with the (charged) hot exhaust gas (not shown).

The method 500 can include operating a power supply to apply a high voltage to the charge source (not shown). Step 512 may include outputting a voltage selected to cause plasma emissions to form along a portion of the fuel and the exhaust gas to the gutter electrode with the power supply. The plasma emissions may continuously ignite an afterburner flame (not shown). According to another embodiment, step 512 may include outputting a voltage selected to cause a luminous emission along a portion of the fuel and the exhaust gas proximate the gutter electrode. The luminous emission may continuously ignite an afterburner flame with (not shown).

**SUBSTITUTE SHEET IN CLEAN COPY**

Operating a power supply to apply a high voltage to the charge source may include applying an alternating current voltage, a time-varying voltage, and/or a periodic voltage waveform having a 50 to 10,000 Hertz frequency. According to another embodiment, a periodic voltage waveform having a 200 to  
5 800 Hertz frequency may be applied. The time-varying voltage can include a square waveform, sine waveform, triangular waveform, truncated triangular waveform, sawtooth waveform, logarithmic waveform, and/or exponential waveform. The time-varying voltage can include a waveform having  $\pm 1000$  volt to  $\pm 115,000$  volt amplitude. According to another embodiment, the time-varying  
10 voltage can include a waveform having  $\pm 8000$  volt to  $\pm 40,000$  volt amplitude.

Operating a power supply to apply a high voltage to the charge source may include holding the gutter electrode at a voltage different than the voltage applied to the charge source and/or applying a second time-varying voltage to the gutter electrode, the second time-varying voltage being opposite in sign to  
15 the time-varying voltage applied to the charge source.

Operating a power supply to apply a high voltage to the charge source may include holding the gutter electrode substantially at voltage ground and/or at a voltage opposite in polarity to the voltage applied to the charge source. The gutter electrode can be electrically isolated from ground and from voltages other  
20 than the voltage applied to the gutter electrode and a voltage attributable to the majority charge.

A flame detector can be included and operated to detect a presence of an afterburner flame by measuring a presence of a flow of the majority charge in continuity with the gutter electrode.  
25

While various aspects and embodiments have been disclosed herein, other aspects and embodiments are contemplated. The various aspects and embodiments disclosed herein are for purposes of illustration and are not intended to be limiting, with the true scope and spirit being indicated by the  
30 following claims.

## CLAIMS

What is claimed is:

1. A gas turbine afterburner, comprising:  
an exhaust pipe aligned to receive exhaust gas from a gas turbine stage;  
a fuel sprayer configured to spray fuel into the exhaust gas;  
a gutter configured as an aerodynamic bluff body to produce vortices in the exhaust gas ;  
a charge source configured to apply a majority charge to the exhaust gas or the fuel; and  
a gutter electrode configured to attract the majority charge toward the gutter.
2. The gas turbine afterburner of claim 1, wherein the gutter and the gutter electrode are electrically isolated from one another.
3. The gas turbine afterburner of claim 1, wherein the gutter is formed from a dielectric material.
4. The gas turbine afterburner of claim 1, further comprising: an electrical isolation flange configured to electrically insulate the exhaust pipe from the gas turbine stage.
5. The gas turbine afterburner of claim 1, wherein the exhaust pipe is at least partially formed from a dielectric material.
6. The gas turbine afterburner of claim 1, further comprising: a fuel isolator configured to electrically insulate the fuel sprayer from the gas turbine.
7. The gas turbine afterburner of claim 1, further comprising:

a plurality of mounting rods configured to support the fuel sprayer, the gutter, and the charge source from a turbine hub; and

one or more mounting rod electrical insulators configured to electrically insulate the mounting rods from the turbine hub.

8. The gas turbine afterburner of claim 1, further comprising:

a plurality of mounting rods configured to support the fuel sprayer, the gutter, and the charge source from a turbine hub; and

one or more mounting rod electrical insulators configured to electrically insulate the fuel sprayer, the gutter, and the charge source from the mounting rods and the turbine hub.

9. The gas turbine afterburner of claim 1, wherein the charge source includes a high voltage wire configured to contact the sprayed fuel.

10. The gas turbine afterburner of claim 1, further comprising an anvil configured to deflect the sprayed fuel.

11. The gas turbine afterburner of claim 1, wherein the charge source includes a dielectric tube aligned to convey charged air into the exhaust gas.

12. The gas turbine afterburner of claim 1, further comprising: an anvil configured to deflect the sprayed fuel;

wherein the charge source and the anvil are combined.

13. The gas turbine afterburner of claim 1, further comprising: an anvil configured to deflect the sprayed fuel;

wherein the charge source and the anvil are formed contiguously.

14. The gas turbine afterburner of claim 1, wherein the gutter and the gutter electrode are in electrical continuity with one another.

15. The gas turbine afterburner of claim 1, further comprising: a power supply configured to apply a high voltage to the charge source.

16. The gas turbine afterburner of claim 15, wherein the power supply is configured to output a voltage selected to cause plasma emissions to form along a portion of the fuel and the exhaust gas to the gutter electrode.

17. The gas turbine afterburner of claim 16, wherein the plasma emissions continuously ignite an afterburner flame.

18. The gas turbine afterburner of claim 15, wherein the power supply is configured to output a voltage selected to cause a luminous emission along a portion of the fuel and the exhaust gas to the gutter electrode.

19. The gas turbine afterburner of claim 18, wherein the luminous emission is associated with ignition of the exothermic reaction.

20. The gas turbine afterburner of claim 15, wherein the power supply is configured to apply a voltage to the exhaust gas to cause the gutter to hold an afterburner flame in an exhaust gas stream having a velocity greater than the flame propagation velocity along the exhaust gas stream absent the gutter electrode.

21. The gas turbine afterburner of claim 15, wherein the power supply is configured to apply an alternating current voltage to the charge source.

22. The gas turbine afterburner of claim 15, wherein the power supply is configured to apply a time-varying voltage to the charge source.

23. The gas turbine afterburner of claim 22, wherein the time-varying voltage includes a periodic voltage waveform having a 50 to 10,000 Hertz frequency.

24. The gas turbine afterburner of claim 23, wherein the time-varying voltage includes a periodic voltage waveform having a 200 to 800 Hertz frequency.

25. The gas turbine afterburner of claim 22, wherein the time-varying voltage includes a square waveform, sine waveform, triangular waveform, truncated triangular waveform, sawtooth waveform, logarithmic waveform, or exponential waveform.

26. The gas turbine afterburner of claim 22, wherein the time-varying voltage includes a waveform having  $\pm 1000$  volt to  $\pm 115,000$  volt amplitude.

27. The gas turbine afterburner of claim 26, wherein the time-varying voltage includes a waveform having  $\pm 8000$  volt to  $\pm 40,000$  volt amplitude.

28. The gas turbine afterburner of claim 22, wherein the power supply is configured to hold the gutter electrode at a voltage different than the voltage applied to the charge source.

29. The gas turbine afterburner of claim 22, wherein the voltage source is configured to apply a second time-varying voltage to the gutter electrode, the second time-varying voltage being opposite in sign to the time-varying voltage applied to the charge source.

30. The gas turbine afterburner of claim 15, wherein the power supply is configured to hold the gutter electrode substantially at voltage ground.

31. The gas turbine afterburner of claim 15, wherein the power supply is further configured to hold the gutter electrode at a voltage opposite in polarity to the voltage applied to the charge source.
32. The gas turbine afterburner of claim 15, wherein the gutter electrode is electrically isolated from ground and from voltages other than the voltage applied to the gutter electrode.
33. The gas turbine afterburner of claim 1, further comprising:  
a flame detector configured to detect a presence of an afterburner flame by measuring a presence of the majority charge in a volume occupied by the afterburner flame.
34. The gas turbine afterburner of claim 1, further comprising:  
a flame detector configured to detect an absence of an afterburner flame by measuring an absence of the majority charge in a volume that would be occupied by the afterburner flame.
35. The gas turbine afterburner of claim 1, wherein the charge source and the gutter electrode are configured to cooperate to produce an ignition arc selected to maintain ignition of an afterburner flame.
36. A method for operating a gas turbine afterburner, comprising:  
applying a majority electrical charge to be carried by a hot exhaust gas;  
receiving the hot exhaust gas from a gas turbine;  
spraying fuel into the hot exhaust gas;  
igniting the fuel to form a flame;  
applying a holding voltage to a gutter electrode; and  
holding the flame in a gas turbine exhaust pipe with a combination of an aerodynamic gutter and an attractive force between the holding voltage applied to the gutter electrode and a majority charge carried by the hot exhaust gas.

37. The method for operating a gas turbine afterburner of claim 36, wherein receiving the hot exhaust gas from the gas turbine comprises receiving the hot exhaust gas from the last stage of the turbine.

38. The method for operating a gas turbine afterburner of claim 36, wherein applying a majority electrical charge to be carried by a hot exhaust gas includes applying a majority charge to a combustion reaction in a combustor; and wherein receiving the hot exhaust gas from the last stage of the gas turbine includes passing the hot combustion gas through at least one gas turbine stage.

39. The method for operating a gas turbine afterburner of claim 36, wherein applying the majority charge includes applying the majority charge to a combustion reaction prior to flowing the combustion reaction toward a first stage of the gas turbine.

40. The method for operating a gas turbine afterburner of claim 36, wherein applying a majority electrical charge to be carried by a hot exhaust gas includes applying the majority electrical charge to the hot exhaust gas at a gas flow node arranged to receive the hot exhaust gas from the gas turbine.

41. The method for operating a gas turbine afterburner of claim 36, wherein applying the majority charge includes applying the majority charge to the fuel.

42. The method for operating a gas turbine afterburner of claim 36, wherein applying the majority charge includes applying the majority charge to the exhaust gas.

43. The method for operating a gas turbine afterburner of claim 36, wherein applying the majority electrical charge to be carried by a hot exhaust gas

includes applying the majority charge in an exhaust pipe aligned to receive exhaust gas from a gas turbine stage.

44. The method for operating a gas turbine afterburner of claim 36, wherein holding the flame in a gas turbine exhaust pipe with a combination of an aerodynamic gutter and an attractive force between the holding voltage applied to the gutter electrode and a majority charge carried by the hot exhaust gas includes producing vortices with an aerodynamic bluff body and attracting the majority charge toward the gutter with a gutter electrode.

45. The method for operating a gas turbine afterburner of claim 36, further comprising:

electrically insulating a conductive surface in intermittent electrical continuity with the (charged) hot exhaust gas.

46. The method for operating a gas turbine afterburner of claim 36, further comprising:

electrically isolating a conductive surface in intermittent electrical continuity with the (charged) hot exhaust gas.

47. The method for operating a gas turbine afterburner of claim 36, wherein applying a majority electrical charge to be carried by a hot exhaust gas with a charge source including a high voltage wire contacting the sprayed fuel.

48. The method for operating a gas turbine afterburner of claim 36, wherein applying a majority electrical charge to be carried by a hot exhaust gas with a charge source including an anvil that deflects the sprayed fuel.

49. The method for operating a gas turbine afterburner of claim 36, wherein applying a majority electrical charge to be carried by a hot exhaust gas includes

flowing a charged fluid through a dielectric tube aligned to convey the charged fluid into the exhaust gas.

50. The method for operating a gas turbine afterburner of claim 36, wherein holding the flame in a gas turbine exhaust pipe with a combination of an aerodynamic gutter and an attractive force between the holding voltage applied to the gutter electrode and a majority charge carried by the hot exhaust gas includes a cooperation between an aerodynamic gutter and a gutter electrode that are in electrical continuity with one another.

51. The method for operating a gas turbine afterburner of claim 36, further comprising: operating a power supply to apply a high voltage to the charge source.

52. The method for operating a gas turbine afterburner of claim 51, wherein holding the flame in a gas turbine exhaust pipe with a combination of an aerodynamic gutter and an attractive force between the holding voltage applied to the gutter electrode and a majority charge carried by the hot exhaust gas includes outputting a voltage selected to cause plasma emissions to form along a portion of the fuel and the exhaust gas to the gutter electrode with the power supply.

53. The method for operating a gas turbine afterburner of claim 52, further comprising:  
continuously igniting an afterburner flame with the plasma emissions.

54. The method for operating a gas turbine afterburner of claim 51, wherein holding the flame in a gas turbine exhaust pipe with a combination of an aerodynamic gutter and an attractive force between the holding voltage applied to the gutter electrode and a majority charge carried by the hot exhaust gas

includes outputting a voltage selected to cause a luminous emission along a portion of the fuel and the exhaust gas proximate the gutter electrode.

55. The method for operating a gas turbine afterburner of claim 54, further comprising:

continuously igniting an afterburner flame with the luminous emission.

56. The method for operating a gas turbine afterburner of claim 51, wherein operating a power supply to apply a high voltage to the charge source includes applying an alternating current voltage to the charge source.

57. The method for operating a gas turbine afterburner of claim 51, wherein operating a power supply to apply a high voltage to the charge source includes applying a time-varying voltage to the charge source.

58. The method for operating a gas turbine afterburner of claim 57, wherein operating a power supply to apply a high voltage to the charge source includes applying a periodic voltage waveform having a 50 to 10,000 Hertz frequency.

59. The method for operating a gas turbine afterburner of claim 58, wherein operating a power supply to apply a high voltage to the charge source includes applying a periodic voltage waveform having a 200 to 800 Hertz frequency.

60. The method for operating a gas turbine afterburner of claim 57, wherein the time-varying voltage includes a square waveform, sine waveform, triangular waveform, truncated triangular waveform, sawtooth waveform, logarithmic waveform, or exponential waveform.

61. The method for operating a gas turbine afterburner of claim 57, wherein the time-varying voltage includes a waveform having  $\pm 1000$  volt to  $\pm 115,000$  volt amplitude.

62. The method for operating a gas turbine afterburner of claim 61, wherein the time-varying voltage includes a waveform having  $\pm 8000$  volt to  $\pm 40,000$  volt amplitude.

63. The method for operating a gas turbine afterburner of claim 57, wherein operating a power supply to apply a high voltage to the charge source includes holding the gutter electrode at a voltage different than the voltage applied to the charge source.

64. The method for operating a gas turbine afterburner of claim 57, wherein operating a power supply to apply a high voltage to the charge source includes applying a second time-varying voltage to the gutter electrode, the second time-varying voltage being opposite in sign to the time-varying voltage applied to the charge source.

65. The method for operating a gas turbine afterburner of claim 51, wherein operating a power supply to apply a high voltage to the charge source includes holding the gutter electrode substantially at voltage ground.

66. The method for operating a gas turbine afterburner of claim 65, wherein operating a power supply to apply a high voltage to the charge source includes holding the gutter electrode at a voltage opposite in polarity to the voltage applied to the charge source.

67. The method for operating a gas turbine afterburner of claim 51, wherein the gutter electrode is electrically isolated from ground and from voltages other than the voltage applied to the gutter electrode and a voltage attributable to the majority charge.

68. The method for operating a gas turbine afterburner of claim 36, further comprising:

operating a flame detector to detect a presence of an afterburner flame by measuring a presence of a flow of the majority charge in continuity with the gutter electrode.

69. The method for operating a gas turbine afterburner of claim 36, wherein applying a holding voltage to a gutter electrode includes maintaining a voltage to produce an ignition arc selected to maintain ignition of an afterburner flame between the hot exhaust gas majority charge and the gutter electrode.

FIG. 1A

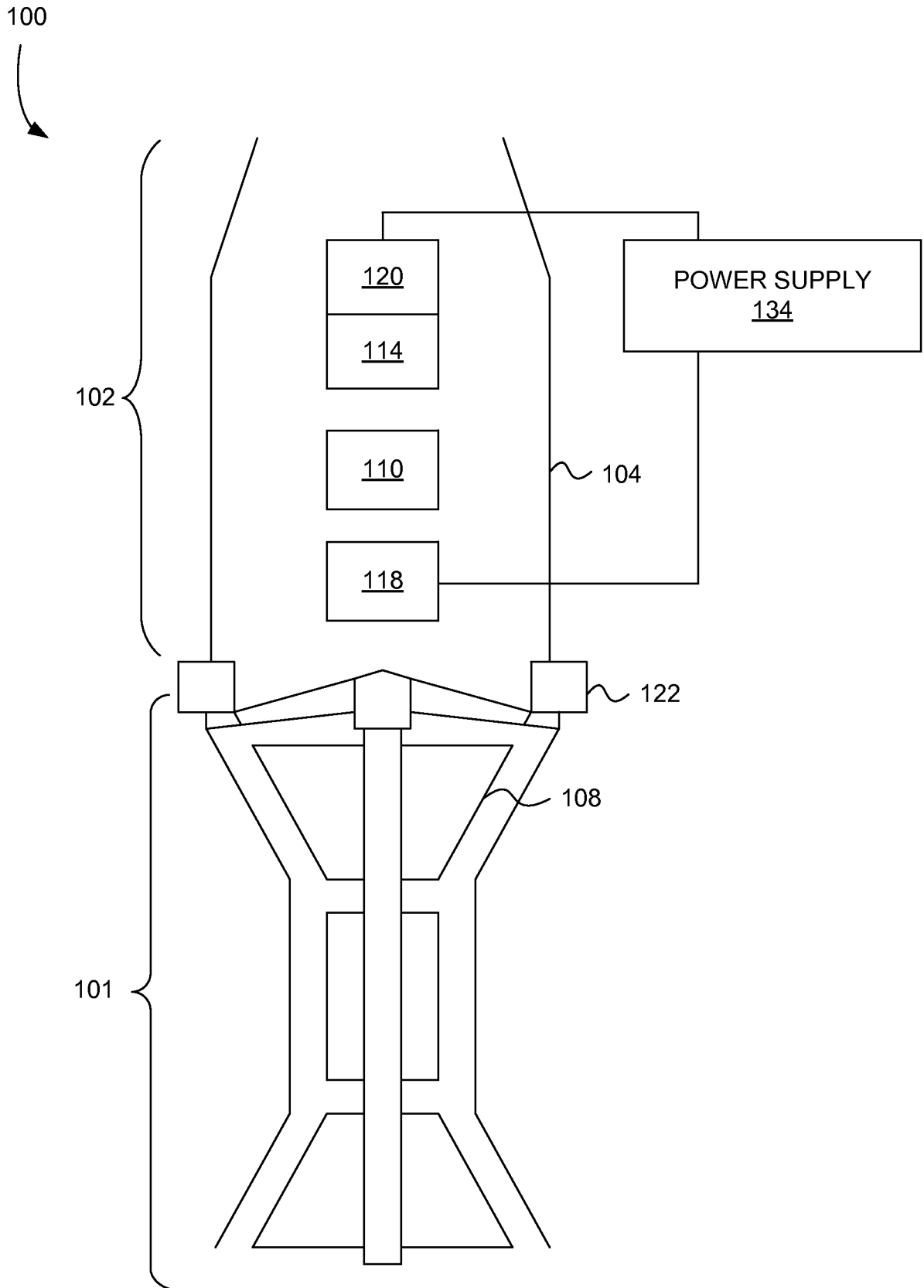
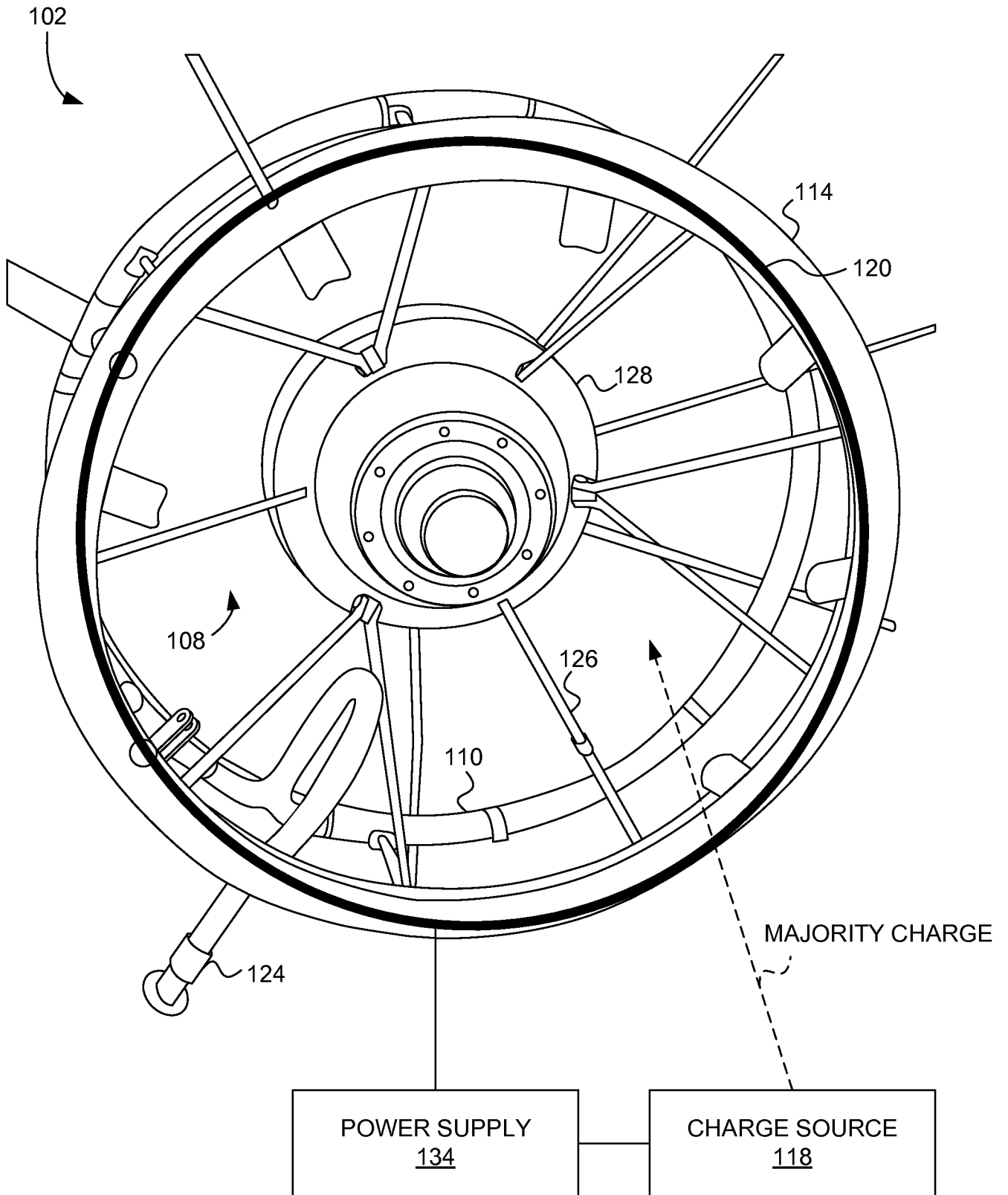
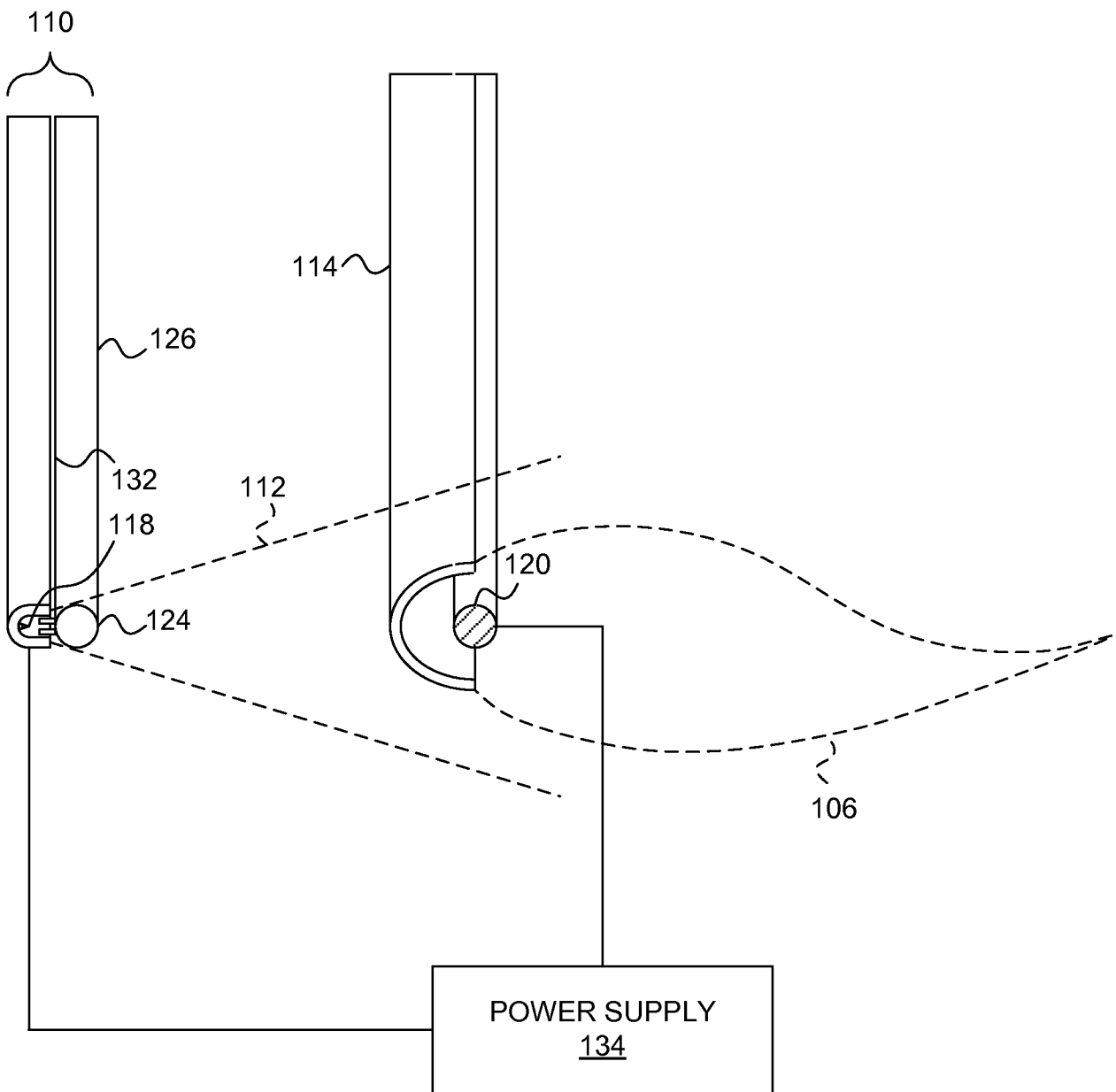

FIG. 1B



200

FIG. 2



SUBSTITUTE SHEET IN CLEAN COPY

300 ↘

FIG. 3

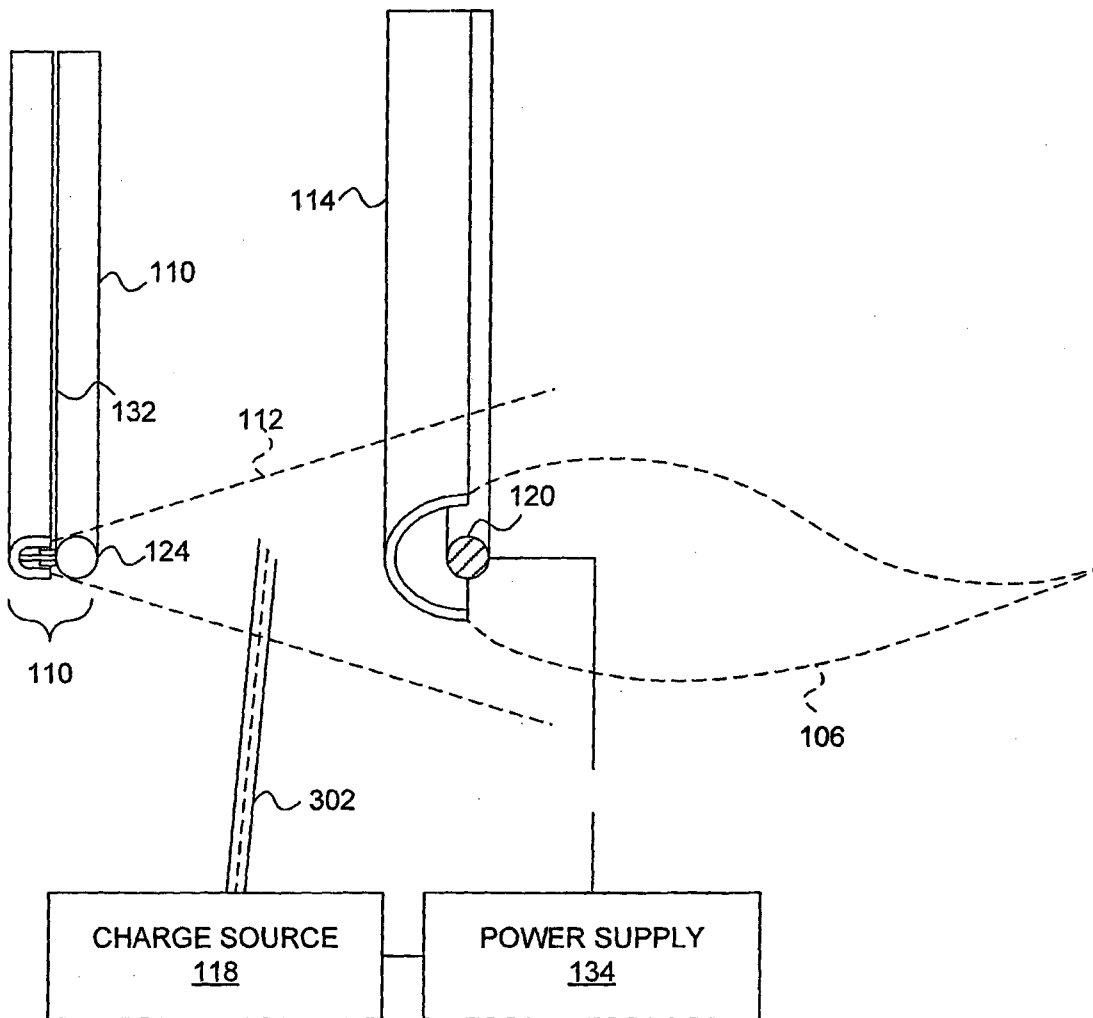

**RECTIFIED SHEET**

400

FIG. 4

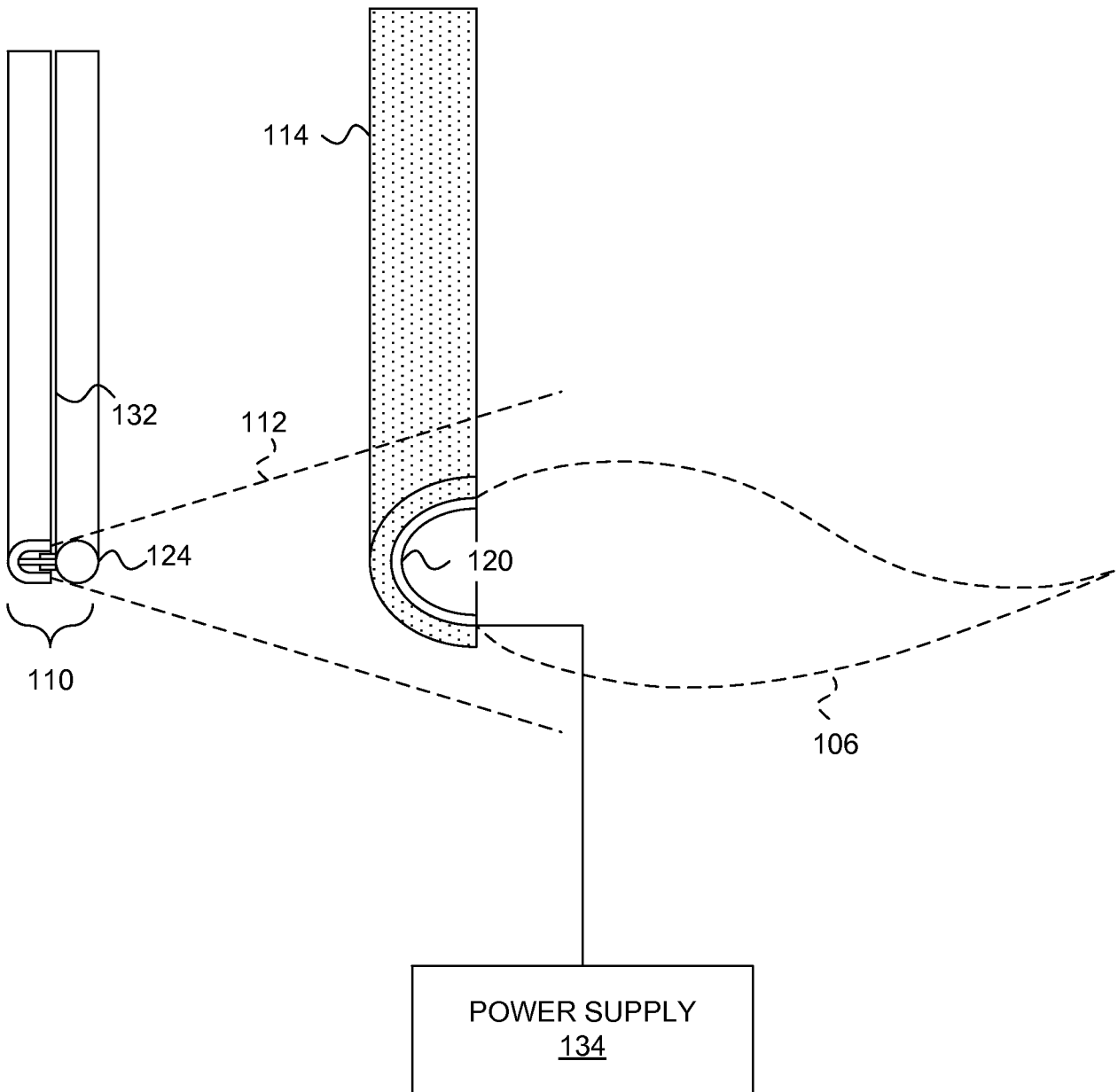
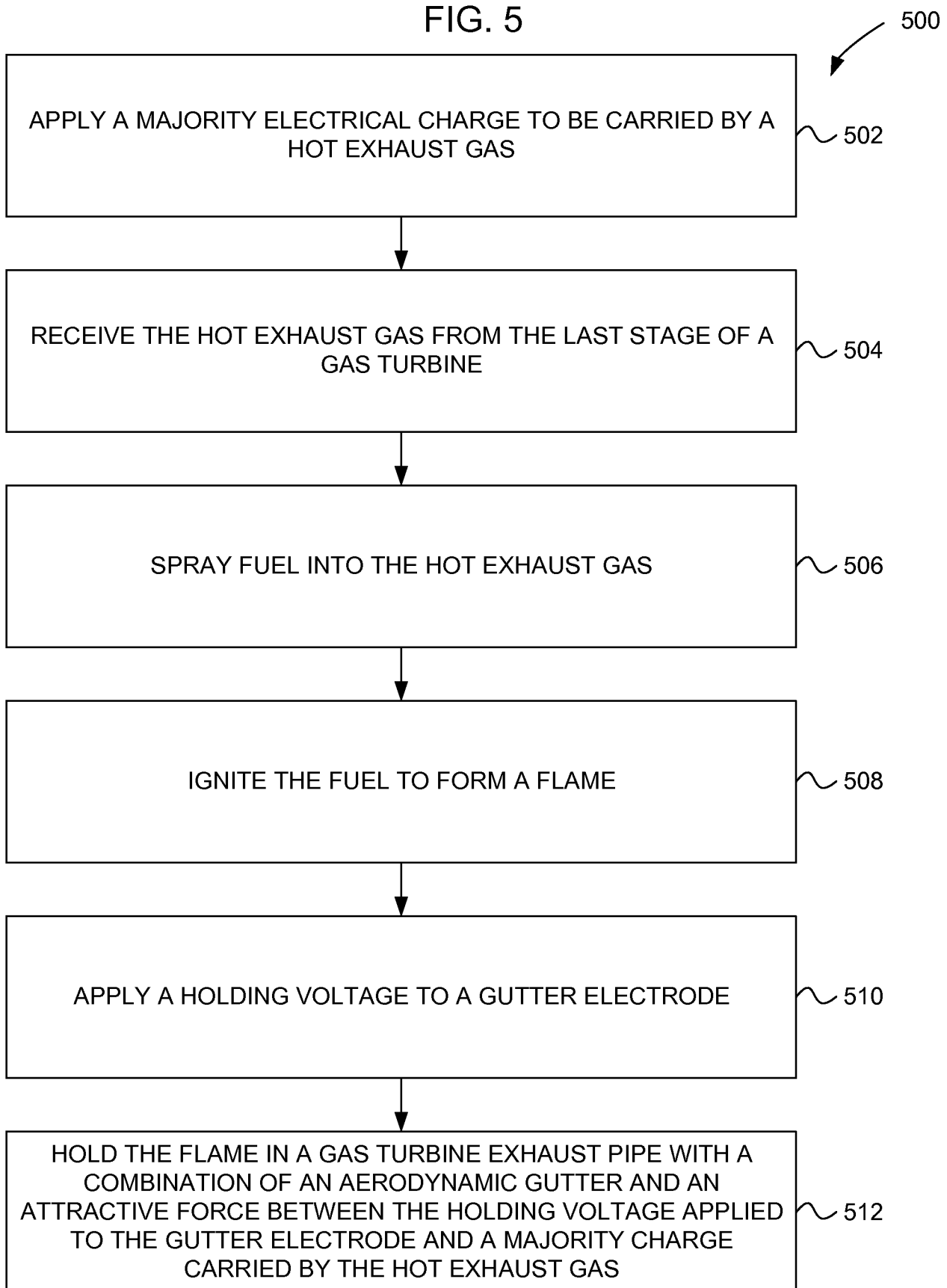

FIG. 5



**A. CLASSIFICATION OF SUBJECT MATTER****F02C 3/00(2006.01)i, F02C 3/20(2006.01)i, F02C 3/14(2006.01)i, F02C 7/22(2006.01)i**

According to International Patent Classification (IPC) or to both national classification and IPC

**B. FIELDS SEARCHED**

Minimum documentation searched (classification system followed by classification symbols)

F02C 3/00; G01L 23/22; F02K 1/38; F02R 3/10; F02K 3/10; F23R 3/20; F02C 3/20; F02C 3/14; F02C 7/22

Documentation searched other than minimum documentation to the extent that such documents are included in the fields searched

Korean utility models and applications for utility models

Japanese utility models and applications for utility models

Electronic data base consulted during the international search (name of data base and, where practicable, search terms used)

eKOMPASS(KIPO internal) &amp; Keywords: turbine, exhaust, afterburner, tailpipe burner, reheater, gutter, flame holder, electrode, charge

**C. DOCUMENTS CONSIDERED TO BE RELEVANT**

Category*	Citation of document, with indication, where appropriate, of the relevant passages	Relevant to claim No.
A	US 5,685,142 A (BREWER et al.) 11 November 1997 See column 3, line 34 - column 4, line 32; figures 2-4.	1-69
A	US 2004-0123653 A1 (BENSON, KELLY J.) 1 July 2004 See paragraphs [0025]-[0027]; figures 1-6.	1-69
A	JP 2006-010179 A (ISHIKAWAJIMA HARIMA HEAVY IND. CO., LTD.) 12 January 2006 See paragraphs [0029]-[0035]; figures 1,3,5.	1-69
A	US 8,061,143 B1 (MAGUIRE, ADDISON CHARLES) 22 November 2011 See column 2, lines 11-56; figures 1-3.	1-69
A	US 2005-0198940 A1 (KOSHOFFER et al.) 15 September 2005 See paragraphs [0055]-[0058]; figures 1,4-5.	1-69



Further documents are listed in the continuation of Box C.



See patent family annex.

\* Special categories of cited documents:

"A" document defining the general state of the art which is not considered to be of particular relevance

"E" earlier application or patent but published on or after the international filing date

"L" document which may throw doubts on priority claim(s) or which is cited to establish the publication date of citation or other special reason (as specified)

"O" document referring to an oral disclosure, use, exhibition or other means

"P" document published prior to the international filing date but later than the priority date claimed

"T" later document published after the international filing date or priority date and not in conflict with the application but cited to understand the principle or theory underlying the invention

"X" document of particular relevance; the claimed invention cannot be considered novel or cannot be considered to involve an inventive step when the document is taken alone

"Y" document of particular relevance; the claimed invention cannot be considered to involve an inventive step when the document is combined with one or more other such documents, such combination being obvious to a person skilled in the art

"&amp;" document member of the same patent family

Date of the actual completion of the international search

05 September 2013 (05.09.2013)

Date of mailing of the international search report

**06 September 2013 (06.09.2013)**

Name and mailing address of the ISA/KR



 Korean Intellectual Property Office  
 189 Cheongsa-ro, Seo-gu, Daejeon Metropolitan City,  
 302-701, Republic of Korea

Facsimile No. +82-42-472-7140

Authorized officer

HAN Joong Sub

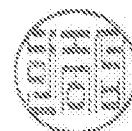
Telephone No. +82-42-481-5606



**INTERNATIONAL SEARCH REPORT**

Information on patent family members

International application No.

**PCT/US2013/038962**

Patent document cited in search report	Publication date	Patent family member(s)	Publication date
US 05685142 A	11/11/1997	None	
US 2004-0123653 A1	01/07/2004	AU 2003-291023 A1 EP 1583945 A1 EP 1618363 A2 EP 1618363 A4 EP 1618363 B1 JP 2006-512531 A JP 2006-523297 A JP 4634807 B2 US 2004-0123652 A1 US 2006-0000260 A1 US 6993960 B2 US 7096722 B2 US 7204133 B2 WO 2004-061403 A1 WO 2004-092650 A2 WO 2004-092650 A3	29/07/2004 12/10/2005 25/01/2006 08/06/2011 12/06/2013 13/04/2006 12/10/2006 23/02/2011 01/07/2004 05/01/2006 07/02/2006 29/08/2006 17/04/2007 22/07/2004 28/10/2004 17/02/2005
JP 2006-010179 A	12/01/2006	None	
US 8061143 B1	22/11/2011	GB 1605456 A	16/07/2008
US 2005-0198940 A1	15/09/2005	DE 602005004572 T2 EP 1574699 A1 EP 1574699 B1 RU 2005106776 A RU 2382894 C2 US 7251941 B2	29/01/2009 14/09/2005 30/01/2008 20/08/2006 27/02/2010 07/08/2007