

E. G. DENISON.  
HEN'S NEST.

APPLICATION FILED AUG. 3, 1904.

2 SHEETS—SHEET 1.

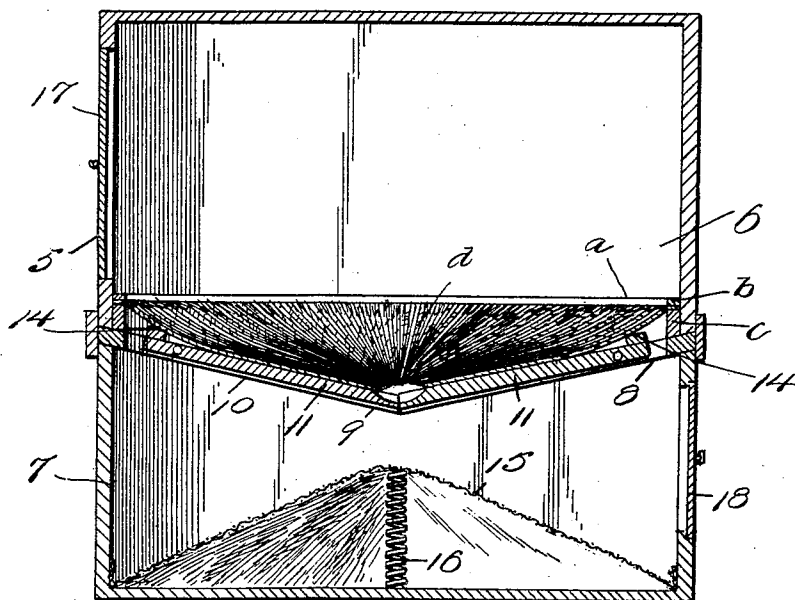

*Fig. 1.*

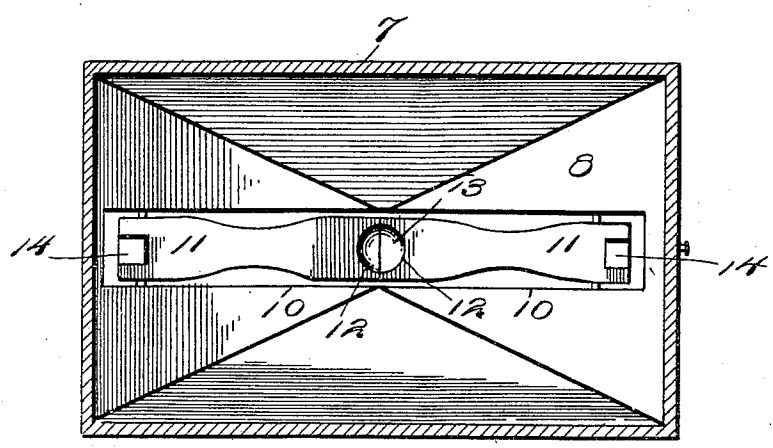

*Fig. 2.*

Witnesses  
*Ambergarn*  
*W. C. Meyer*

Inventor  
*E. G. Denison*  
By *Charles Chandler*  
Attorneys

No. 792,007.

PATENTED JUNE 13, 1905.

E. G. DENISON.  
HEN'S NEST.

APPLICATION FILED AUG. 3, 1904.

2 SHEETS—SHEET 2.

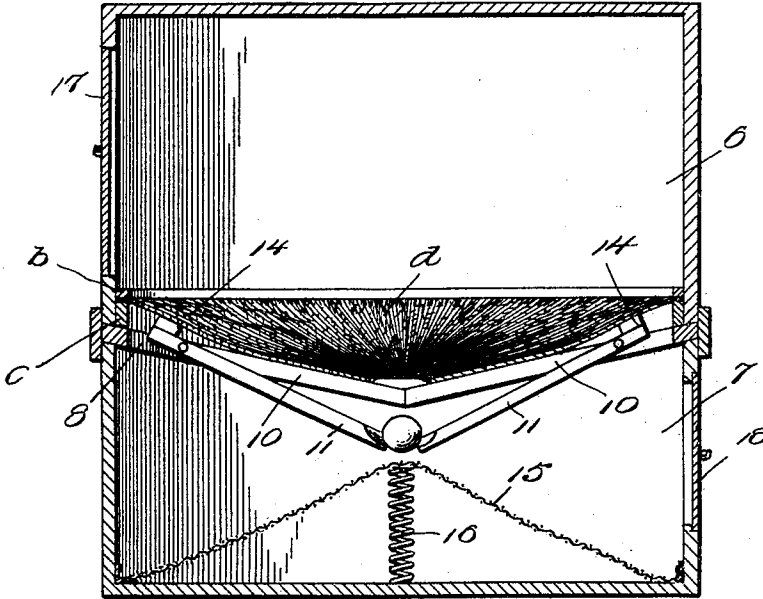

Fig. 3.

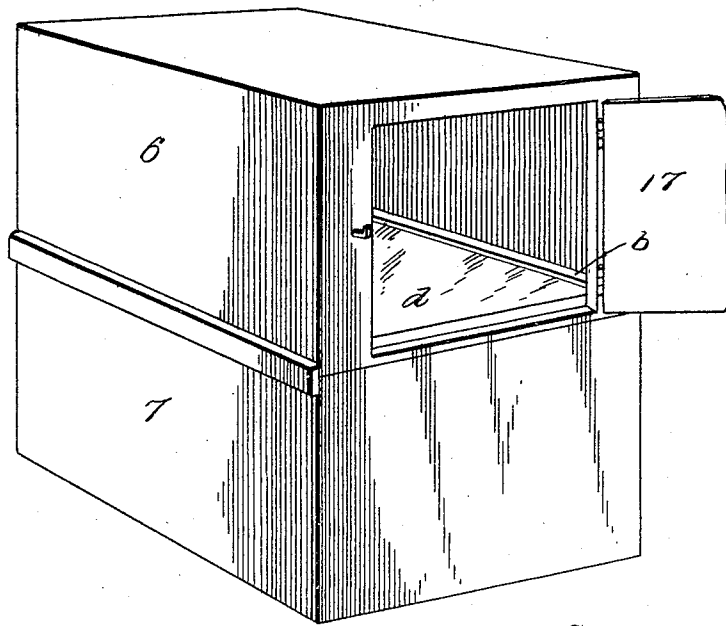

Fig. 4.

Witnesses  
C. M. Simpson  
W. C. Keyes

Inventor  
E. G. Denison  
By  
Charles J. Francis  
Attorneys

# UNITED STATES PATENT OFFICE.

EVERETT G. DENISON, OF SPICKARD, MISSOURI.

## HEN'S NEST.

SPECIFICATION forming part of Letters Patent No. 792,007, dated June 13, 1905.

Application filed August 3, 1904. Serial No. 219,341.

*To all whom it may concern:*

Be it known that I, EVERETT G. DENISON, a citizen of the United States, residing at Spickard, in the county of Grundy, State of Missouri, have invented certain new and useful Improvements in Hens' Nests; and I do hereby declare the following to be a full, clear, and exact description of the invention, such as will enable others skilled in the art to which it appertains to make and use the same.

This invention relates to nests for hens, and has for its object to provide a nest so arranged that when an egg is laid therein it will be automatically conveyed to a compartment beneath the nest proper, thus preventing breakage of the eggs by the fowls.

A further object is to provide a construction which will permit of removal of the eggs from the lower compartment without disturbing a hen which may be upon the nest.

Other objects and advantages will be apparent from the following description, and it will be understood that modifications of the specific construction shown may be made and any suitable materials may be used without departing from the spirit of the invention.

In the drawings forming a portion of this specification, and in which like characters of reference indicate similar parts in the several views, Figure 1 is a sectional view of the present invention, taken vertically thereof. Fig. 2 is a top plan view of the partition. Fig. 3 is a view similar to Fig. 1, showing an egg in the act of passing to the lower compartment. Fig. 4 is a perspective view of the complete invention, showing one of the doors open.

Referring now to the drawings, the present invention comprises a hollow body portion 5, divided into upper and lower compartments 6 and 7 by means of a horizontal partition or floor 8, which slants downwardly from its edges to its center, at which point it is provided with a slot 10, which passes through the lowest point, and pivoted in this slot are levers 11, which meet at their inner ends, and these levers have recesses 12 in their upper faces communicating with their meeting ends, which together form a pocket 13.

The levers 11 are pivoted adjacent to their outer ends, and each is provided at its outer

end with a weight 14 to hold them with their inner ends normally raised and in engagement with each other, and these weights are of such a size that they will be overbalanced by the weight of an egg resting in the pocket 13, 55 the levers being moved upon their pivots to permit the egg to pass therebetween into the compartment 7. This compartment has secured to its walls and spaced from its bottom a cloth 15, and disposed between the cloth at 60 its center and the bottom of the compartment is a helical spring 16, which holds the center of the cloth normally raised, and it will be apparent that an egg passing from the compartment 6 will fall upon the raised portion of 65 the cloth and will roll therefrom to the side portions thereof, the cloth thus acting as a cushion to prevent breaking of the egg.

The compartment 6 is provided with a door 17 at one side of the body portion, which may 70 be opened to permit a fowl to enter the nest, and at the opposite side of the body portion the compartment 7 is provided with a door 18, through which the eggs may be removed from the compartment. The doors being thus 75 disposed at opposite sides of the body portion, the eggs may be removed without disturbing a hen which may be upon the nest.

A framework *a* is provided, consisting of two portions *b* and *c*, the latter being disposed 80 above the former, and between these two portions are secured the outer ends of cords *d*, which thus extend inwardly from the framework. The framework is of such a size that it may be disposed upon the floor 8 and will 85 rest thereupon at the edges of the floor, and it will be readily understood that when the frame is thus disposed the cords will lie upon the floor and will extend in the direction of the central opening 9 and will present an ap- 90 pearance similar to that of a real nest.

What is claimed is—

1. A device of the class described, comprising a hollow body portion having a horizontal partition therewithin, said partition slanting downwardly from its sides to its center and having a slot therewithin extending through 95 its lowest point, levers pivoted in the slot and arranged for mutual engagement of their inner ends, the meeting ends of said levers lying 100

at the lowest point of the partition, said levers having recesses in their upper faces at their meeting ends arranged to form together an egg-receiving pocket, and means for holding the levers yieldably with their meeting ends in engagement with each other, said levers being arranged for movement under the weight of an egg resting upon their meeting ends to permit of the passage of said egg between their ends.

2. A device of the class described comprising a hollow body portion having a horizontal partition therewithin, said partition slanting downwardly from its sides to its center and having an opening therethrough at its center, said opening being of a size to permit of the passage of an egg therethrough, pivotally-mounted levers lying with their inner ends in engagement with each other, said ends lying at the center of the partition and arranged to receive an egg thereupon through the opening of the partition, means for holding the levers yieldably with their inner ends in engagement with each other, said levers being arranged for movement under the weight of an egg resting upon their meeting ends to permit of the passage of said egg between their

ends, and a cushion disposed within the lower compartment and arranged to receive eggs from the upper compartment.

3. A device of the class described comprising a hollow body portion having a horizontal partition therewithin to form an upper nest-compartment and a lower egg-receiving compartment, said partition slanting downwardly from its sides to its center and having an opening therethrough for the passage of eggs from the upper to the lower compartment, and a framework arranged for disposal upon the partition and to rest thereupon adjacent to the edges thereof, said framework comprising upper and lower portions and cords secured each with an end between the portions of the frame and extending inwardly of the frame and arranged to lie upon the partition and to extend in the direction of the central opening when the frame is in position.

In testimony whereof I affix my signature in presence of two witnesses.

EVERETT G. DENISON.

Witnesses:

E. E. SANDERS,  
ESTHER GOBEN.