

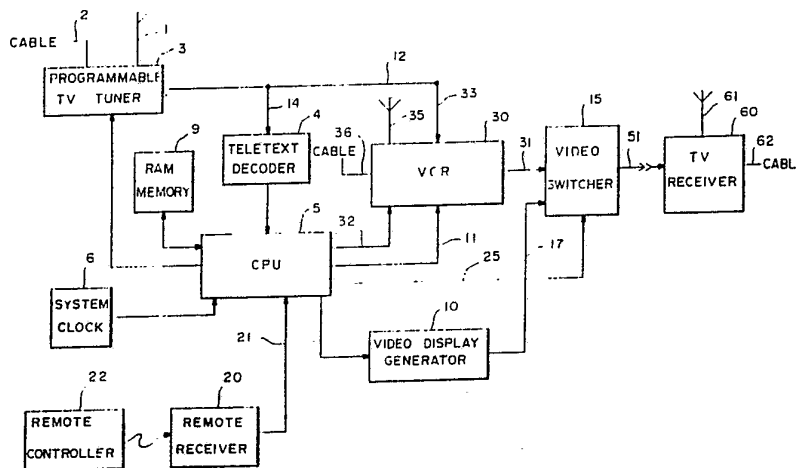

INTERNATIONAL APPLICATION PUBLISHED UNDER THE PATENT COOPERATION TREATY (PCT)

<p>(51) International Patent Classification⁴ : H04N 7/087, 7/04, G11B 27/02 H04H 1/00</p>	<p>A1</p>	<p>(11) International Publication Number: WO 90/00847 (43) International Publication Date: 25 January 1990 (25.01.90)</p>
<p>(21) International Application Number: PCT/US89/02927 (22) International Filing Date: 10 July 1989 (10.07.89) (30) Priority data: 219,971 15 July 1988 (15.07.88) US (71) Applicant: INSIGHT TELECAST, INC. [US/US]; 1496 Cherrywood Drive, San Mateo, CA 94403 (US). (72) Inventor: YOUNG, Patrick ; 1496 Cherrywood Drive, San Mateo, CA 94403 (US). (74) Agents: NISHIMURA, Keiichi et al.; Flehr, Hohbach, Test, Albritton & Herbert, Four Embarcadero Center, Suite 3400, San Francisco, CA 94111-4187 (US).</p>		<p>(81) Designated States: AT (European patent), AU, BE (European patent), CH (European patent), DE (European patent), FR (European patent), GB (European patent), IT (European patent), JP, KR, LU (European patent), NL (European patent), SE (European patent). Published <i>With international search report.</i> <i>With amended claims.</i></p>

(54) Title: SYSTEM AND PROCESS FOR VCR SCHEDULING



(57) Abstract

A VCR schedule controller receives broadcast data over antenna (1) or cable (2) by a programmable tuner (3), which is connected to a teletext receiver (4). The teletext receiver (4) is connected to a microprocessor (5). Microprocessor output (11) is connected to a video display generator (10), used to create text for television receiver (60) to display a message from the microprocessor (5). After processing embedded data in a broadcast, the microprocessor (5) generates a cue for display on TV receiver (60). Remote control receiver (20) receives a command from a remote controller (22) from a viewer input in response to the cue. Remote control receiver (20) supplies a control signal to cause the microprocessor to store the embedded data in memory (9). The microprocessor then issues a message to the display generator (10) as an acknowledgement of the viewer input. The microprocessor (5) monitors the system clock (6) and compares it with stored schedules from the embedded supplemental data. When the system time corresponds to one of the scheduled times, the microprocessor (5) sets the programmable tuner (3) to the stored channel and initiates recording on VCR (30).

FOR THE PURPOSES OF INFORMATION ONLY

Codes used to identify States party to the PCT on the front pages of pamphlets publishing international applications under the PCT.

AT	Austria	ES	Spain	MG	Madagascar
AU	Australia	FI	Finland	ML	Mali
BB	Barbados	FR	France	MR	Mauritania
BE	Belgium	GA	Gabon	MW	Malawi
BF	Burkina Fasso	GB	United Kingdom	NL	Netherlands
BG	Bulgaria	HU	Hungary	NO	Norway
BJ	Benin	IT	Italy	RO	Romania
BR	Brazil	JP	Japan	SD	Sudan
CA	Canada	KP	Democratic People's Republic of Korea	SE	Sweden
CF	Central African Republic	KR	Republic of Korea	SN	Senegal
CG	Congo	LI	Liechtenstein	SU	Soviet Union
CH	Switzerland	LK	Sri Lanka	TD	Chad
CM	Cameroon	LU	Luxembourg	TG	Togo
DE	Germany, Federal Republic of	MC	Monaco	US	United States of America
DK	Denmark				

- 1 -

SYSTEM AND PROCESS FOR VCR SCHEDULING

CROSS REFERENCE TO RELATED INVENTION

This invention relates to an improvement in the invention described in my earlier U.S. Patent 4,706,121, issued November 10, 1987 and entitled "TV Schedule System and Process."
5

BACKGROUND OF THE INVENTION

1. Field of the Invention:

The present invention further relates generally to a system and process in which television supplemental data is embedded in a televised broadcast and, on cue, the viewer can store the supplemental data. Such supplemental data can include schedule information, such as time, channel, program name and program type. The stored data is used to program a VCR automatically for recording a supplemental televised program as defined by the schedule information.
10
15

2. Description of the Prior Art:

The above-referenced related patent describes a system and process which allows user selection of broadcast programs from schedule information for presentation to a television set and/or recording by a VCR. The prior art discussed in that patent and of record in its application shows a variety of systems and processes for increasing the functionality of a television set and/or a VCR.
20
25

- 2 -

While a number of such systems and processes are known in this art, none of these systems and processes deal with a way to provide supplemental information about material being broadcast to a viewer. An example of such supplemental information that would be of substantial interest to certain viewers is further information on a product that is advertised during a regular broadcast. Such commercial time is very expensive, particularly during prime time or televised sporting events with very large audiences, so that commercials have a typical length of from 30 seconds to one minute. For many advertised products, viewers need more information than can be provided during the commercials on, for example, features, prices and local availability before they make a decision to purchase the product. The ability to provide such supplemental information selectively to viewers who desire it would be of substantial value to advertisers and other suppliers of televised information.

SUMMARY OF THE INVENTION

Accordingly, it is an object of this invention to provide a system and process which will allow a viewer to select interactively to receive supplemental information related to material in a television broadcast.

It is another object of the invention to provide such a system and process which will provide the supplemental information for recording when broadcast time is inexpensive.

It is a further object of the invention to provide such a system and process which will allow viewers to select supplemental information from a menu.

It is another object of the invention to provide a VCR schedule controller that provides an improved index of recorded material on a tape.

The attainment of these and related objects may be achieved through use of the novel system and process for

- 3 -

VCR scheduling herein disclosed. A system and process for VCR scheduling in accordance with this invention has a recording device, a broadcast receiver and a data processor connected to the recording device and to the broadcast receiver. The data processor includes means for presenting a cue on the broadcast receiver during the broadcast. A means is connected to the data processor for receiving a user response to the cue. A means responsive to the user response to the cue controls the recording device to record the supplemental information.

A process for presenting supplemental information about a broadcast in accordance with the invention includes providing a cue during a broadcast indicating the availability of supplemental information relating to the broadcast. A response to the cue is received from the user. The supplemental information is supplied to the user after receiving the cue response from the user. Preferably, the supplemental information is broadcast at a later time. Schedule information for the supplemental information is provided with the broadcast. The schedule information is stored after the user response to the cue and used to record the supplemental information with a recording device when the supplemental information is broadcast.

This apparatus allows supplemental information to be delivered to the viewer selectively, at a time that is beneficial and convenient for broadcasters, and retrieved by the viewer in a prompt and convenient way. One method of sending supplemental data is using the video blanking interval (VBI) segment of the video signal to carry teletext-formatted data. A teletext receiver-based apparatus is used to decode the supplemental data.

The cue may be a caption on the screen, an audio signal or message, an indicator on the apparatus, or anything that can alert the viewer. The cue may be generated selectively by the apparatus, based on the

- 4 -

content of the supplemental data received, or the cue may be contained in the normal televised video picture or sound. The viewer responds to the cue by pushing a key on a remote controller, by a switch on the apparatus, by making a loud sound, or by any other means that will activate the system to store the supplemental data in memory.

When the viewer successfully stores the data on cue, the system may issue an acknowledgement. This may be another caption, an audio signal or message, or anything else to inform the viewer that the response to the cue has been entered. The system will then automatically tune the VCR to the scheduled channel and time defined by the supplemental data.

The attainment of the foregoing and related objects, advantages and features of the invention should be more readily apparent to those skilled in the art, after review of the following more detailed description of the invention, taken together with the drawings, in which:

BRIEF DESCRIPTION OF THE DRAWINGS

Figure 1 is a block diagram of a system for VCR scheduling in accordance with the invention.

Figure 2 is a block diagram of another system for VCR scheduling in accordance with the invention.

DETAILED DESCRIPTION OF THE INVENTION

Turning now to the drawings, more particularly to Figure 1, there is shown a block diagram of an integrated VCR schedule controller in accordance with the invention. In this embodiment, the controller is provided built into a VCR, but it can also be provided separate from the VCR, such as by using the remote facility of the VCR to provide inputs to the VCR.

Broadcast data is received over antenna 1 or cable 2 by a programmable tuner 3, which has an output connected

- 5 -

to input 14 of a teletext receiver 4. The teletext receiver may be a Sears Caption Decoder. The output of the teletext receiver 4 is connected to a microprocessor 5. Microprocessor output 11 is connected to a video display generator 10, used to create text for television receiver 60. Video switcher 15 connects the display generator 10 output 17 to the TV receiver 60 to display a message from the microprocessor 5.

The microprocessor 5 has a random access memory 9 and a system clock/calendar 6. After processing the embedded data, the microprocessor 5 generates a cue by outputting a symbol or message to the display generator 10 for display on TV receiver 60. Remote control receiver 20 receives a command from a remote controller 22 from a viewer input in response to the cue. Remote control receiver 20 is connected to an input line 21 and supplies a control signal to cause the microprocessor to store the embedded data in memory 9. The microprocessor then issues a message to the display generator 10 as an acknowledgement of the viewer input.

The cue can be implemented in many ways other than through the microprocessor 5. The simplest is an audio or visual stimulus that is part of the sound or video portion of the broadcast. In this case, both the display generator 10 and the video switcher 15 are unnecessary. The provision of the cue separate from the sound or video portion of the broadcast, such as in the VBI, which is then added to the sound or video portion of the signal provided to the TV receiver 60 by the microprocessor, is not distracting to viewers without the system of this invention.

The microprocessor 5 monitors the system clock 6 and compares it with the stored schedules from the embedded supplemental data. When the system time corresponds to one of the scheduled times, the microprocessor 5 sets the programmable tuner 3 to the stored channel and initiates

- 6 -

recording on VCR 30 by a control signal on line 32. The VCR receives its signal from antenna 35 or cable 36.

In addition to obtaining schedule information as part of a broadcast, in a system 90 as shown in Figure 2, the
5 schedule information can be received by a computer 5 using a modem 94 and processed by the computer 5. Based on user selections, one or more program schedule listings is stored in computer memory. At the time of the broad-
10 casts, the computer 5 activates a VCR 30 for recording of the selected programs. Serial output port 32 of the computer 5 connects to a control bus of the VCR 30 to turn on the VCR, control channel selection and enable recording of the program.

The system 90 incorporates a feature for automatical-
15 ly converting television guide station listings to channel selections for cable users. To eliminate need to convert station listings to local channel numbers each time the VCR 30 is to be programmed for unattended recording, a memory is provided so that the user only needs to enter
20 the conversion once. After that, the conversion is handled by the computer 5. An entry table is provided on-screen requesting the user to enter a cable channel number corresponding to each station name or number. Alternativa-
25 tively, both the station name or number and the cable number may be read from a bar-code conversion guide, using a bar-code reader. In either method, the conversion data is stored in a table in memory. During unattended
30 recording, the channel number corresponding to the station name is used by the computer 5 to control channel selection on the VCR 30. With such a conversion stored locally in the system 90, cable schedule information can be supplied under cable channel names (e.g., ESPN) on a regional or national basis and selection of the appropriate local channel number for that cable service made by
35 the controller 90.

- 7 -

The system 90 uses electronic indexing for automatic retrieval of programs. During recording, the location of the program is identified by a capstan counter with a digital readout. This index information identifying where a program to be recorded is stored into a log along with the name of the program. During playback, the VCR 30 will automatically go to the indexed location and start playback.

Line 101 from the VCR 30 is a serial bus containing the index data. It is connected to a serial input port of the computer 5. Search is made by comparing the present index value and the stored index value. Search is completed when the index value from the VCR 30 matches the stored index value.

The system 90 also provides self-indexed cassette recordings. At the start of each cassette tape, a complete description of the start and end positions of every program recorded on the cassette is stored along with the program names. During playback, this information is read by the teletext decoder of the VCR 30 and presented on the screen, allowing the user to identify quickly what is recorded and to access the desired program automatically. Access is made by name selection from the log.

During recording, a complete log is created for each tape as described above. Before the tape is removed from the VCR 30, the tape is rewound to the start, and the log information is recorded onto video blanking interval (VBI) tracks of the tape using a VBI data encoder 110 of the type described in my above-referenced issued patent. Line 102 is a serial output from the computer 5 to the VBI encoder 110 and line 103 is the video signal with the embedded log information connecting to the video input port of the VCR 30. While the log information is recorded, the VCR 30 receives its signals from the antenna input 35 to the video input.

- 8 -

During playback, a VBI teletext decoder 108 receives data from the VCR on line 107, which is the video output port of VCR 30. After decoding, the data is received on line 106 by computer 5 on a second input port. Other than
5 as shown and described, the construction and operation of the Figure 2 embodiment of the invention is the same as that of the Figure 1 embodiment.

Further details on implementing systems of this invention are available in my above-referenced issued
10 patent, the disclosure of which is incorporated by reference herein.

It should now be apparent to those skilled in the art that a novel VCR schedule system and process capable of achieving the stated objects of the invention has been
15 provided. The system and process allows interactive selection by a viewer of further information related to information being broadcast, which may be made with a menu selection. The further information can be broadcast for recording by a viewer at a different time, when broadcast
20 time is less costly and/or underutilized.

It should further be apparent to those skilled in the art that various changes in form and details of the invention as shown and described may be made. It is intended that such changes be included within the spirit
25 and scope of the claims appended hereto.

- 9 -

WHAT IS CLAIMED IS:

1. A system to allow interactive selection for presentation to a user of supplemental information pertaining to a broadcast, which comprises a recording device, a broadcast receiver, a data processor connected to said recording device and to said broadcast receiver, said data processor including means for presenting a cue on the broadcast receiver during the broadcast, means connected to the data processor for receiving a user response to the cue, and means responsive to the user response to the cue for controlling said recording device to record the supplemental information.

2. The system to allow interactive selection for presentation to a user of supplemental information pertaining to a broadcast of Claim 1 in which the supplemental information is broadcast at a later time, schedule information for the supplemental information is provided with the broadcast, and said data processor is configured to store the schedule information in response to the user response to the cue and to use the schedule information to record the supplemental information with said recording device when the supplemental information is broadcast.

3. The system to allow interactive selection for presentation to a user of supplemental information pertaining to a broadcast of Claim 2 in which said recording device is a video cassette recorder and said broadcast receiver is a television set.

4. The system to allow interactive selection for presentation to a user of supplemental information pertaining to a broadcast of Claim 1 in which said data processor is further configured to provide acknowledgment to the user of the user response to the cue.

- 10 -

5 5. The system to allow interactive selection for
presentation to a user of supplemental information
pertaining to a broadcast of Claim 1 in which said data
processor is further configured to provide a menu display
to the user in response to a user response to the cue and
to receive user menu selections.

10 6. The system to allow interactive selection for
presentation to a user of supplemental information
pertaining to a broadcast of Claim 1 in which said system
includes means for creating and storing an index of
recorded material.

15 7. The system to allow interactive selection for
presentation to a user of supplemental information
pertaining to a broadcast of Claim 6 in which said system
includes means for recording the index on a tape including
the recorded material.

20 8. A system for recording and indexing broadcast
information, which comprises a recording device for
receiving and recording the broadcast information, means
for receiving and storing schedule information, a data
processor connected to said recording device, said data
processor including means for creating and storing an
index of location and identification of recorded broadcast
information from index inputs received from the schedule
information and from said recording device.

30 9. A system for recording and indexing broadcast
information, which comprises a recording device for
receiving and recording the broadcast information, a data
processor connected to said recording device, and data
processor including means for creating and storing an
index of recorded broadcast information, said system

35

- 11 -

including means for recording the index on a recording medium including the recorded material.

5 10. The system for recording and indexing broadcast information of Claim 9 in which said system includes means for selecting broadcast information for recording from schedule information and said means for creating and storing the index is configured to compile the index from the schedule information.

10

 11. A process to allow interactive selection for presentation to a user of supplemental information pertaining to a broadcast, which comprises providing a cue during a broadcast indicating the availability of supplemental information relating to the broadcast, receiving a response to the cue from the user, and supplying the supplemental information to the user after receiving the cue response from the user.

15

 12. The process to allow interactive selection for presentation to a user of supplemental information pertaining to a broadcast of Claim 11 in which the supplemental information is broadcast at a later time, schedule information for the supplemental information is provided with the broadcast, the process further comprising storing the schedule information after the user response to the cue and using the schedule information to record the supplemental information with a recording device when the supplemental information is broadcast.

20

25

30

 13. The process to allow interactive selection for presentation to a user of supplemental information pertaining to a broadcast of Claim 11 additionally comprising providing acknowledgment to the user of the user response to the cue.

35

- 12 -

14. The process to allow interactive selection for presentation to a user of supplemental information pertaining to a broadcast of Claim 11 additionally comprising providing a menu display to the user in response to a user response to the cue, receiving user menu selections, and supplying the supplemental information in accordance with the user menu selections.

15. The process to allow interactive selection for presentation to a user of supplemental information pertaining to a broadcast of Claim 11 additionally comprising creating and storing an index of recorded material.

16. The process to allow interactive selection for presentation to a user of supplemental information pertaining to a broadcast of Claim 15 additionally comprising recording the index on a tape including the recorded material.

17. A process for recording and indexing broadcast information, which comprises receiving and recording the broadcast information, creating and storing an index of recorded broadcast information, and recording the index on a recording medium including the recorded material.

18. The process for recording and indexing broadcast information of Claim 17 additionally comprising selecting broadcast information for recording from schedule information and in which the index is created from the schedule information.

19. The system of Claim 8 in which said means for creating and storing an index is configured to store at least a title of the broadcast information as the index input from the schedule information.

- 13 -

20. The system of Claim 19 in which said means for
creating and storing an index is configured to store at
least a numeric location of the recorded information as
5 the index input from the recording device.

AMENDED CLAIMS

[received by the International Bureau
on 18 December 1989 (18.12.89);
original claims 1-20 replaced by amended claims 1-20 (5 pages)]

1. A system which comprises a recording device, a broadcast receiver, and a data processor connected to said recording device and to said broadcast receiver, characterized by said system allowing interactive selection for presentation to a user of supplemental broadcast information pertaining to a primary broadcast, said data processor including means for presenting a cue on the broadcast receiver during the primary broadcast at a first time, means connected to the data processor for receiving a user response to the cue, and means responsive to the user response to the cue for controlling said recording device to record the supplemental broadcast information at a second time later than the first time.

2. The system to allow interactive selection for presentation to a user of supplemental broadcast information pertaining to a primary broadcast of Claim 1 further characterized in that schedule information for the supplemental broadcast information is provided with and in addition to the primary broadcast, and said data processor is configured to store the schedule information in response to the user response to the cue and to use the schedule information to record the supplemental broadcast information with said recording device when the supplemental broadcast information is broadcast.

3. The system to allow interactive selection for presentation to a user of supplemental broadcast information pertaining to a primary broadcast of Claim 2 further characterized in that said recording device is a video cassette recorder and said broadcast receiver is a television set.

4. The system to allow interactive selection for presentation to a user of supplemental broadcast informa-

tion pertaining to a primary broadcast of Claim 1 further characterized in that said data processor is configured to provide acknowledgment to the user of the user response to the cue.

5 5. The system to allow interactive selection for presentation to a user of supplemental broadcast information pertaining to a primary broadcast of Claim 1 further characterized in that said data processor is configured to provide a menu display to the user in response to a user
10 response to the cue and to receive user menu selections.

6. The system to allow interactive selection for presentation to a user of supplemental broadcast information pertaining to a primary broadcast of Claim 1 further characterized in that said system includes means for
15 creating and storing an index of recorded material.

7. The system to allow interactive selection for presentation to a user of supplemental broadcast information pertaining to a primary broadcast of Claim 6 further characterized in that said system includes means for
20 recording the index on a tape including the recorded material.

8. A system for recording broadcast information, including a recording device for receiving and recording the broadcast information, means for receiving and storing
25 schedule information and a data processor connected to said recording device, characterized by said data processor including means for creating and storing an index of location and identification of recorded broadcast information from index inputs received from the schedule information
30 and from said recording device.

9. A system for recording and indexing broadcast information, which comprises a recording device for receiving and recording the broadcast information and a data processor connected to said recording device, characterized in that said data processor includes means for creating and storing an index of recorded broadcast information and said system includes means for recording the index on a recording medium including the recorded material.

10. The system for recording and indexing broadcast information of Claim 9 further characterized in that said system includes means for selecting broadcast information for recording from schedule information and said means for creating and storing the index is configured to compile the index from the schedule information.

11. A process including providing a primary broadcast and receiving the primary broadcast, characterized by the process allowing interactive selection for presentation to a user of supplemental broadcast information pertaining to the primary broadcast, the process including the steps of providing a cue during the primary broadcast at a first time indicating the availability at a second time later than the first time of the supplemental broadcast information relating to the primary broadcast, receiving a response to the cue from the user, and supplying the supplemental broadcast information to the user at the second time after receiving the cue response from the user.

12. The process to allow interactive selection for presentation to a user of supplemental broadcast information pertaining to a primary broadcast of Claim 11 further characterized in that schedule information for the supplemental broadcast information is provided with the

primary broadcast, the process further comprising storing the schedule information after the user response to the cue and using the schedule information to record the supplemental broadcast information with a recording device
5 when the supplemental broadcast information is broadcast.

13. The process to allow interactive selection for presentation to a user of supplemental broadcast information pertaining to a primary broadcast of Claim 11 further characterized by providing acknowledgment to the user of
10 the user response to the cue.

14. The process to allow interactive selection for presentation to a user of supplemental broadcast information pertaining to a primary broadcast of Claim 11 further characterized by providing a menu display to the user in
15 response to a user response to the cue, receiving user menu selections, and supplying the supplemental broadcast information in accordance with the user menu selections.

15. The process to allow interactive selection for presentation to a user of supplemental broadcast information pertaining to a primary broadcast of Claim 11 further
20 characterized by recording the supplemental program information, creating an index of the recorded supplemental program information and storing the index.

16. The process to allow interactive selection for presentation to a user of supplemental broadcast information pertaining to a primary broadcast of Claim 15 further
25 characterized by recording the index on a tape including the recorded supplemental program information.

17. A process for recording broadcast information,
30 which comprises receiving and recording the broadcast information, characterized by creating and storing an

index of the recorded broadcast information, and recording the index on a recording medium including the recorded broadcast information.

5 18. The process for recording and indexing broadcast information of Claim 17 further characterized by selecting broadcast information for recording from schedule information and creating the index from the schedule information.

10 19. The system for recording and indexing broadcast information of Claim 8 further characterized in that said means for creating and storing an index is configured to store at least a title of the broadcast information as the index input from the schedule information.

15 20. The system for recording and indexing broadcast information of Claim 19 further characterized in that said means for creating and storing an index is configured to store at least a numeric location of the recorded information as the index input from the recording device.

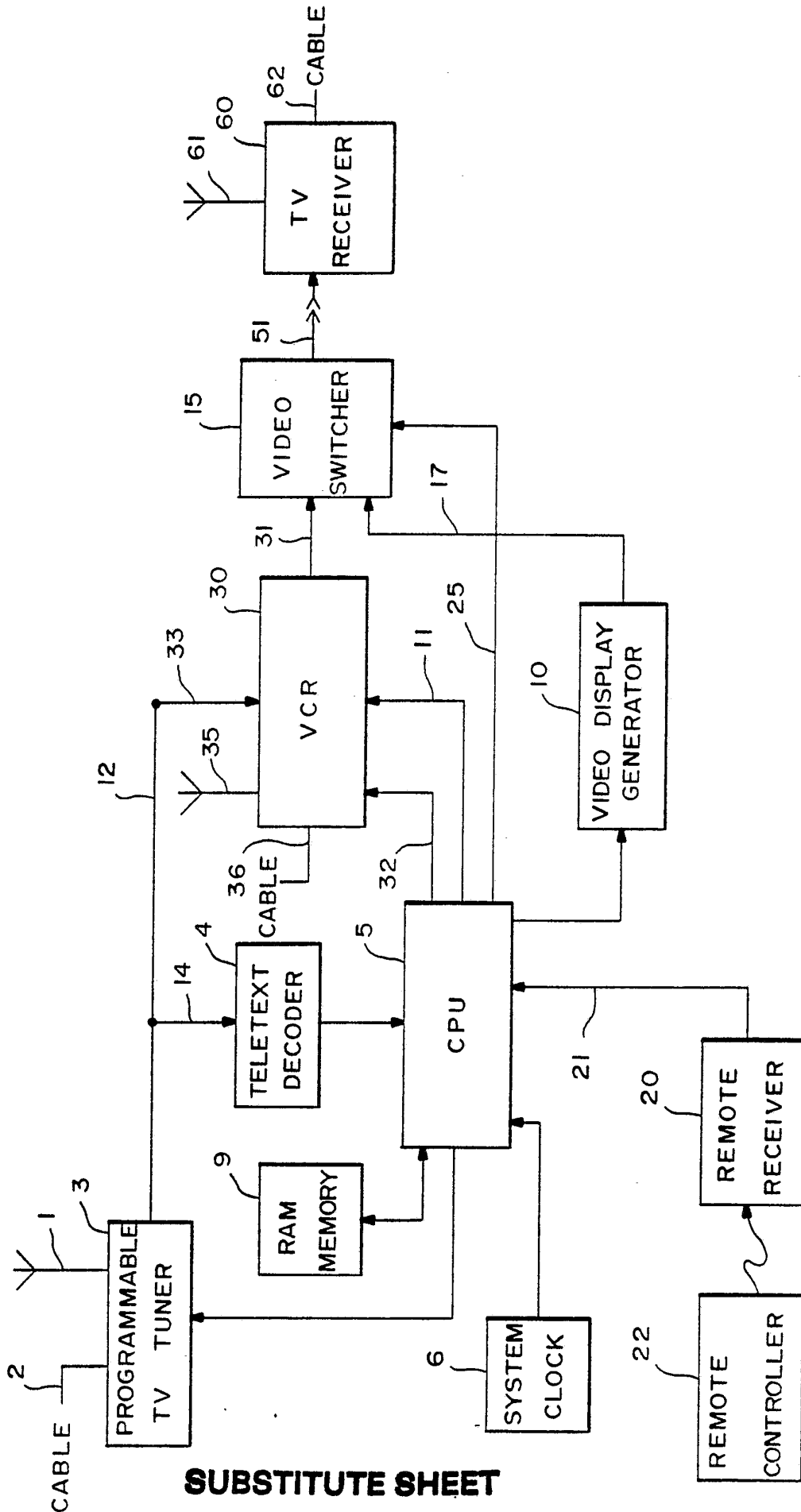

SUBSTITUTE SHEET

FIG. 1

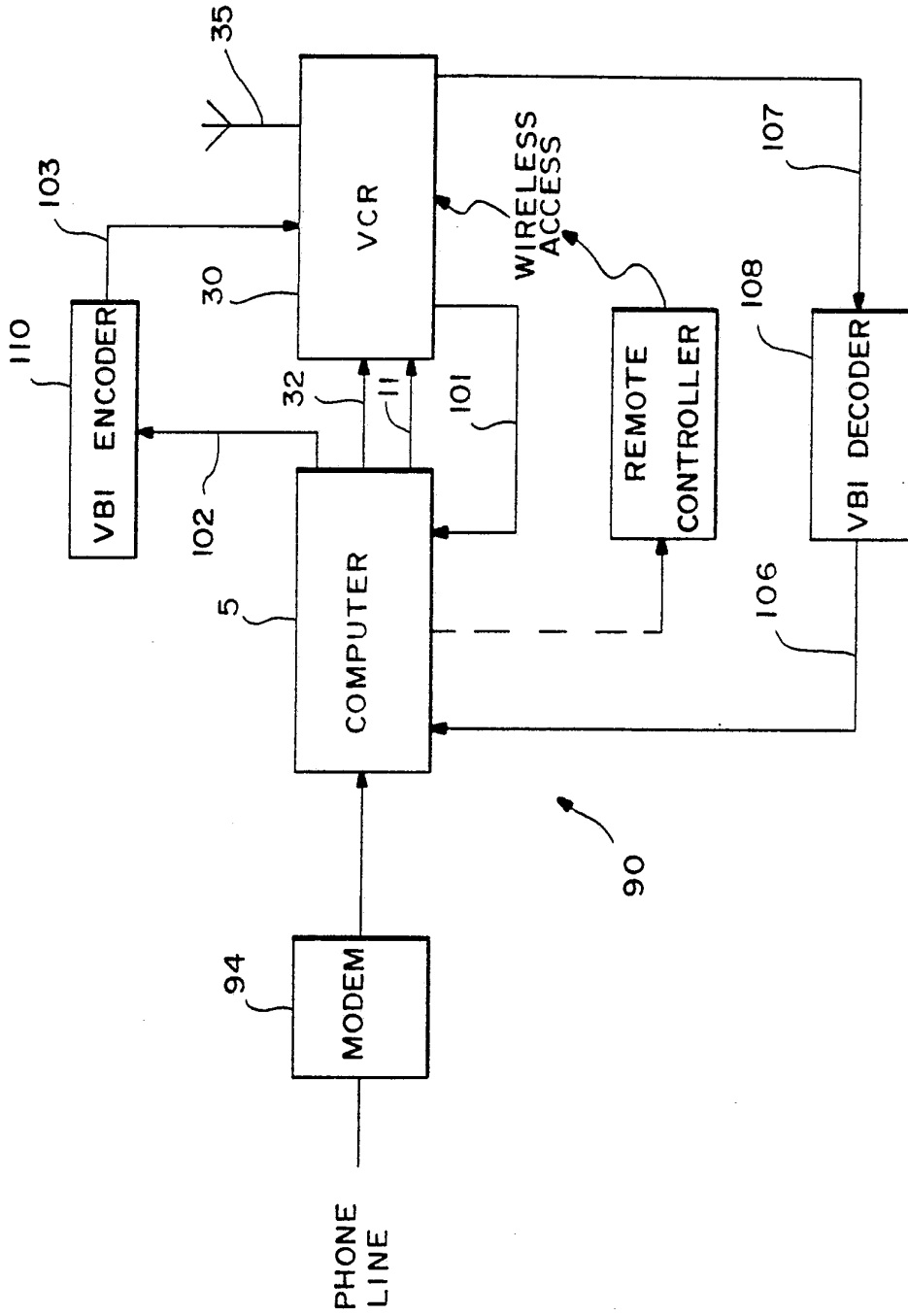

FIG.—2

INTERNATIONAL SEARCH REPORT

International Application No. PCT/US 89/02927

I. CLASSIFICATION OF SUBJECT MATTER (if several classification symbols apply, indicate all) ⁶		
According to International Patent Classification (IPC) or to both National Classification and IPC IPC(4): H04N 7/087, 7/04; G11B 27/02; H04H 1/00 US. CL.: 358/86, 142, 147; 360/13, 72.1; 455/2, 4		
II. FIELDS SEARCHED		
Minimum Documentation Searched ⁷		
Classification System	Classification Symbols	
U.S.	358/85, 86, 142, 146, 147, 194.1, 311, 335, 908 360/13, 69, 72.1, 72.2 455/2, 4	
Documentation Searched other than Minimum Documentation to the Extent that such Documents are Included in the Fields Searched ⁸		
III. DOCUMENTS CONSIDERED TO BE RELEVANT ⁹		
Category [*]	Citation of Document, ¹¹ with indication, where appropriate, of the relevant passages ¹²	Relevant to Claim No. ¹³
X	WO, A 88/04507 (Chambers) British Broadcasting Corporation 16 June 1988 See Entire Document	1-5, 11-14
&,A	US, A 4,706,121 (Young) 10 November 1987	1-7, 11-16
P,A	GB, A 2,207,314 (Kingham) Philips Electronic and Associated Industries Limited 25 January 1989	
A	US, A 4,305,101 (Yarbrough et al.) 08 December 1981	
P,A	US, A 4,821,102 (Ichikawa et al.) 11 April 1989	
A	GB, A 2,185,670 (Calif) 22 July 1987	
<p>[*] Special categories of cited documents: ¹⁰</p> <p>"A" document defining the general state of the art which is not considered to be of particular relevance</p> <p>"E" earlier document but published on or after the international filing date</p> <p>"L" document which may throw doubts on priority claim(s) or which is cited to establish the publication date of another citation or other special reason (as specified)</p> <p>"O" document referring to an oral disclosure, use, exhibition or other means</p> <p>"P" document published prior to the international filing date but later than the priority date claimed</p> <p>"T" later document published after the international filing date or priority date and not in conflict with the application but cited to understand the principle or theory underlying the invention</p> <p>"X" document of particular relevance; the claimed invention cannot be considered novel or cannot be considered to involve an inventive step</p> <p>"Y" document of particular relevance; the claimed invention cannot be considered to involve an inventive step when the document is combined with one or more other such documents, such combination being obvious to a person skilled in the art.</p> <p>"&" document member of the same patent family</p>		
IV. CERTIFICATION		
Date of the Actual Completion of the International Search		Date of Mailing of this International Search Report
04 October 1989		20 OCT 1989
International Searching Authority		Signature of Authorized Officer
ISA/US		<i>Michael Parker</i> Michael Parker

FURTHER INFORMATION CONTINUED FROM THE SECOND SHEET

V. OBSERVATIONS WHERE CERTAIN CLAIMS WERE FOUND UNSEARCHABLE ¹

This international search report has not been established in respect of certain claims under Article 17(2) (a) for the following reasons:

1. Claim numbers _____ because they relate to subject matter ¹ - not required to be searched by this Authority, namely.

2. Claim numbers _____, because they relate to parts of the international application that do not comply with the prescribed requirements to such an extent that no meaningful international search can be carried out ¹, specifically:

3. Claim numbers _____, because they are dependent claims not drafted in accordance with the second and third sentences of PCT Rule 6.4(a).

VI. OBSERVATIONS WHERE UNITY OF INVENTION IS LACKING ²

This International Searching Authority found multiple inventions in this international application as follows:

- I. Claims 1-7 and 11-16 drawn to recording supplemental data in response to a user's response to a cue classified in Class 358 subclass 147.
 - II. Claims 8, 9 and 17-20 drawn to a recording device recording an index of received and recorded information classified in class 360 subclass 13.
1. As all required additional search fees were timely paid by the applicant, this international search report covers all searchable claims of the international application. Telephone Practice
 2. As only some of the required additional search fees were timely paid by the applicant, this international search report covers only those claims of the international application for which fees were paid, specifically claims:
 3. No required additional search fees were timely paid by the applicant. Consequently, this international search report is restricted to the invention first mentioned in the claims; it is covered by claim numbers:
 4. As all searchable claims could be searched without effort justifying an additional fee, the International Searching Authority did not invite payment of any additional fee.
- Remark on Protest
- The additional search fees were accompanied by applicant's protest.
 - No protest accompanied the payment of additional search fees.