

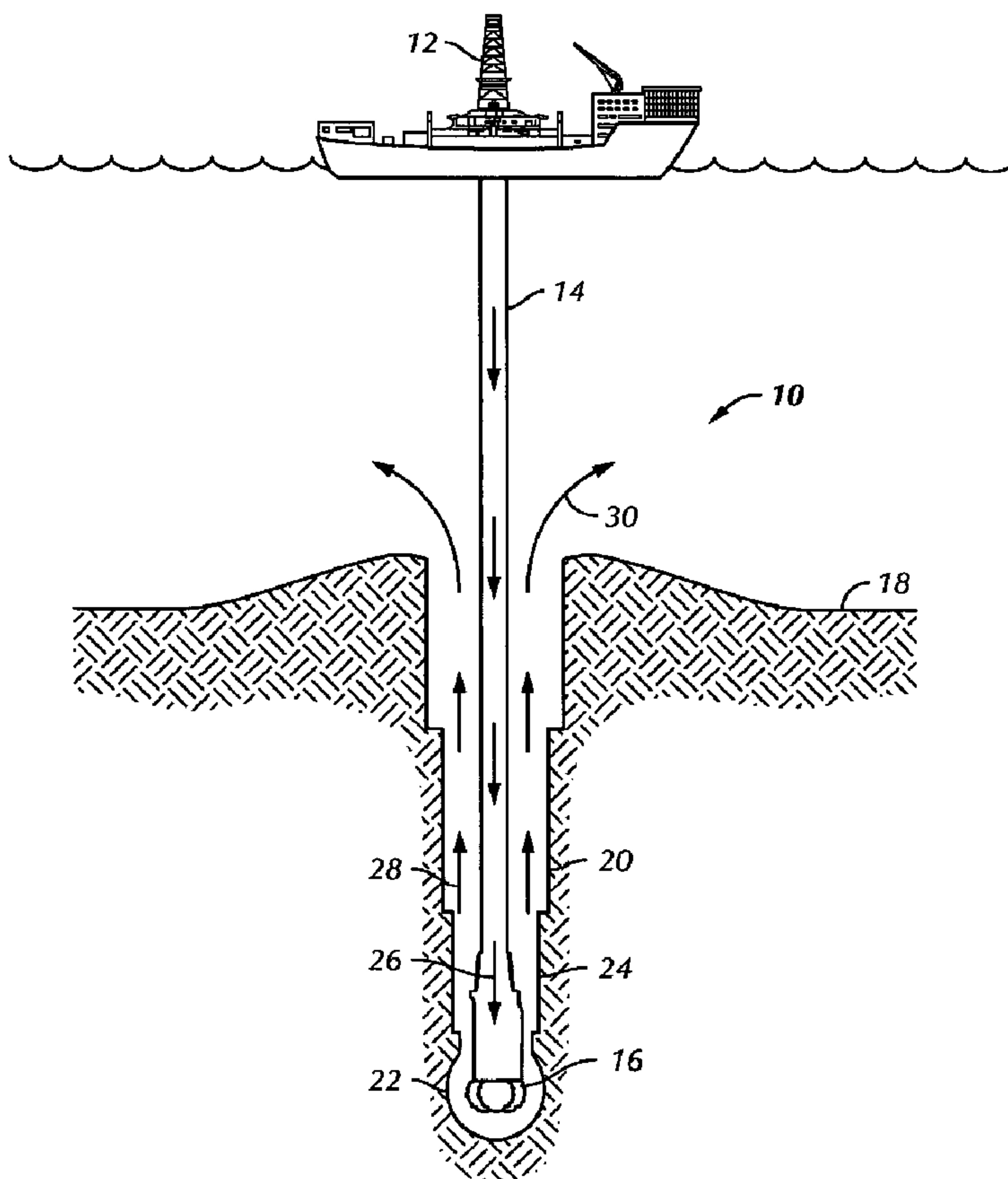

(86) Date de dépôt PCT/PCT Filing Date: 2007/04/19
 (87) Date publication PCT/PCT Publication Date: 2007/11/01
 (45) Date de délivrance/Issue Date: 2011/09/20
 (85) Entrée phase nationale/National Entry: 2008/10/15
 (86) N° demande PCT/PCT Application No.: US 2007/066983
 (87) N° publication PCT/PCT Publication No.: 2007/124368
 (30) Priorités/Priorities: 2006/04/19 (US60/793,031);
 2007/04/18 (US11/737,058)

(51) Cl.Int./Int.Cl. *C09K 8/16* (2006.01),
E21B 7/12 (2006.01), *E21B 7/20* (2006.01)
 (72) Inventeurs/Inventors:
 JONES, DOUG, US;
 RAY, RANDY, US;
 FORRESTER, JAY, US
 (73) Propriétaire/Owner:
 M-I LLC, US
 (74) Agent: SMART & BIGGAR

(54) Titre : FLUIDE DISPERSIF DE FORAGE SANS TUBE PROLONGATEUR
 (54) Title: DISPERSIVE RISERLESS DRILLING FLUID



(57) **Abrégé/Abstract:**

A method for drilling riserless that includes providing a drilling fluid to a drilling assembly for drilling a borehole on a seafloor, the drilling assembly comprising a drill string and a bottomhole assembly, and wherein the drilling fluid includes a brine, and a non-hydratable clay, wherein the drilling fluid is substantially free of hydrating clays, and flowing the drilling fluid and cuttings through an annulus formed by the drill string and the borehole into sea water is disclosed.

(12) INTERNATIONAL APPLICATION PUBLISHED UNDER THE PATENT COOPERATION TREATY (PCT)

(19) World Intellectual Property Organization
International Bureau(43) International Publication Date
1 November 2007 (01.11.2007)

PCT

(10) International Publication Number
WO 2007/124368 A3(51) International Patent Classification:
E21B 43/00 (2006.01) *E21B 43/11* (2006.01)(74) Agents: BERGMAN, Jeffrey, S. et al.; Osha. Liang LLP,
1221 McKinney St., Suite 2800, Houston, TX 77010 (US).(21) International Application Number:
PCT/US2007/066983(81) Designated States (*unless otherwise indicated, for every kind of national protection available*): AE, AG, AL, AM, AT, AU, AZ, BA, BB, BG, BH, BR, BW, BY, BZ, CA, CH, CN, CO, CR, CU, CZ, DE, DK, DM, DZ, EC, EE, EG, ES, FI, GB, GD, GE, GH, GM, GT, HN, HR, HU, ID, IL, IN, IS, JP, KE, KG, KM, KN, KP, KR, KZ, LA, LC, LK, LR, LS, LT, LU, LY, MA, MD, MG, MK, MN, MW, MX, MY, MZ, NA, NG, NI, NO, NZ, OM, PG, PH, PL, PT, RO, RS, RU, SC, SD, SE, SG, SK, SL, SM, SV, SY, TJ, TM, TN, TR, TT, TZ, UA, UG, US, UZ, VC, VN, ZA, ZM, ZW.

(22) International Filing Date: 19 April 2007 (19.04.2007)

(25) Filing Language: English

(26) Publication Language: English

(30) Priority Data:
60/793,031 19 April 2006 (19.04.2006) US
11/737,058 18 April 2007 (18.04.2007) US(71) Applicant (*for all designated States except US*): M-ILLC
[US/US]; 5950 North Course Drive, Houston, TX 77072 (US).

(72) Inventors; and

(75) Inventors/Applicants (*for US only*): JONES, Doug
[US/US]; 11934 Summerdale Street, Houston, TX 77077 (US). RAY, Randy [US/US]; 3924 University Blvd., Houston, TX 77005 (US). FORRESTER, Jay [US/US]; 4510 Holly Street, Bellaire, TX 77401 (US).(84) Designated States (*unless otherwise indicated, for every kind of regional protection available*): ARIPO (BW, GH, GM, KE, LS, MW, MZ, NA, SD, SL, SZ, TZ, UG, ZM, ZW), Eurasian (AM, AZ, BY, KG, KZ, MD, RU, TJ, TM), European (AT, BE, BG, CH, CY, CZ, DE, DK, EE, ES, FI, FR, GB, GR, HU, IE, IS, IT, LT, LU, LV, MC, MT, NL, PL, PT, RO, SE, SI, SK, TR), OAPI (BF, BJ, CF, CG, CI, CM, GA, GN, GQ, GW, ML, MR, NE, SN, TD, TG).

[Continued on next page]

(54) Title: DISPERSIVE RISERLESS DRILLING FLUID

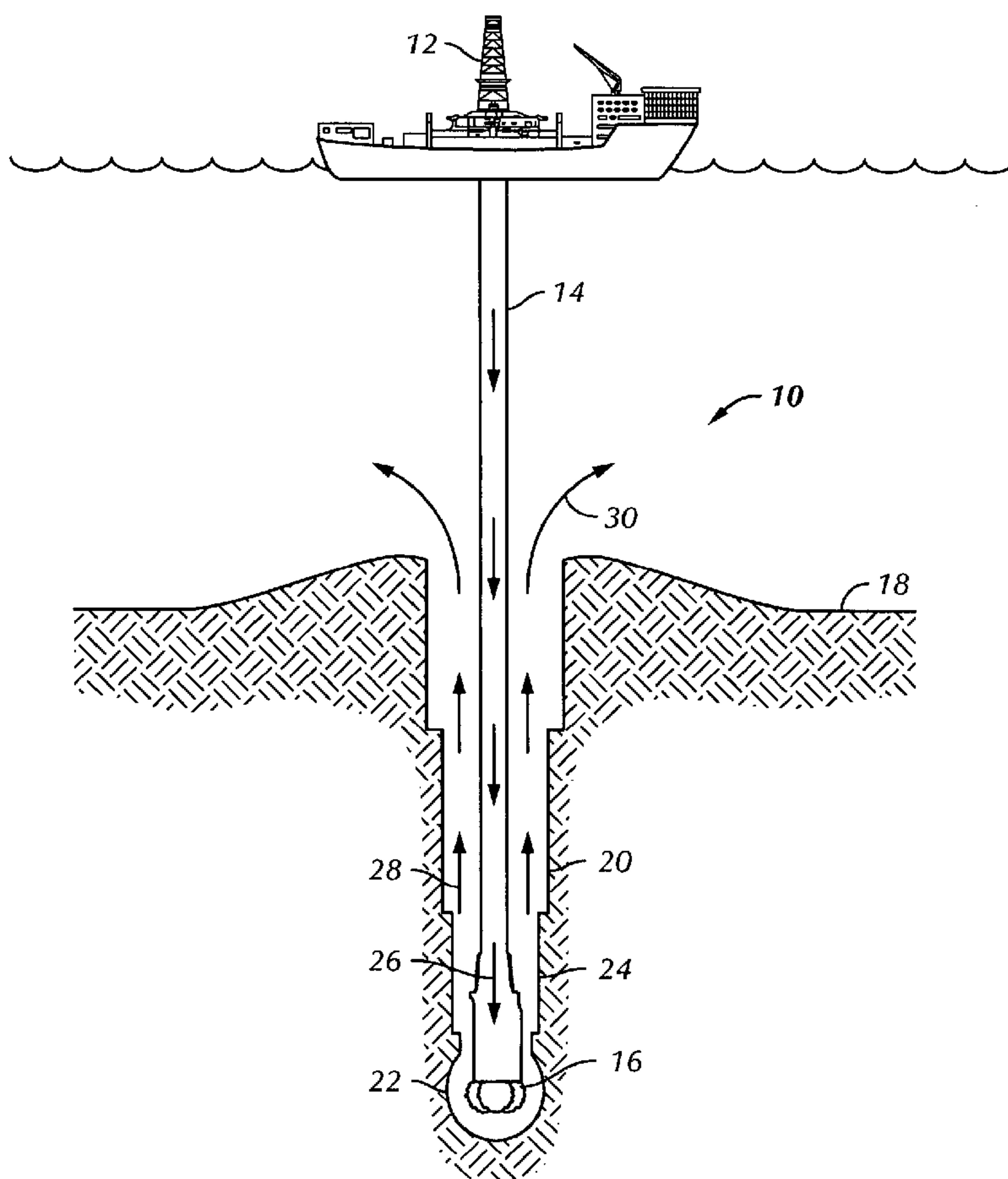

(57) Abstract: A method for drilling riserless that includes providing a drilling fluid to a drilling assembly for drilling a borehole on a seafloor, the drilling assembly comprising a drill string and a bottomhole assembly, and wherein the drilling fluid includes a brine, and a non-hydratable clay, wherein the drilling fluid is substantially free of hydrating clays, and flowing the drilling fluid and cuttings through an annulus formed by the drill string and the borehole into sea water is disclosed.

WO 2007/124368 A3

WO 2007/124368 A3



Published:

- *with international search report*
- *before the expiration of the time limit for amending the claims and to be republished in the event of receipt of amendments*

For two-letter codes and other abbreviations, refer to the "Guidance Notes on Codes and Abbreviations" appearing at the beginning of each regular issue of the PCT Gazette.

(88) Date of publication of the international search report:

6 December 2007

DISPERSIVE RISERLESS DRILLING FLUID

BACKGROUND OF INVENTION

Field of the Invention

[0001] Embodiments relate generally to drilling fluids. More specifically, embodiments relate to drilling fluids used in a riserless section.

Background Art

[0002] When drilling or completing wells in earth formations, various fluids typically are used in the well for a variety of reasons. Common uses for well fluids include: lubrication and cooling of drill bit cutting surfaces while drilling generally or drilling-in (i.e., drilling in a targeted petroliferous formation), transportation of “cuttings” (pieces of formation dislodged by the cutting action of the teeth on a drill bit) to the surface, controlling formation fluid pressure to prevent blowouts, maintaining well stability, suspending solids in the well, minimizing fluid loss into and stabilizing the formation through which the well is being drilled, fracturing the formation in the vicinity of the well, displacing the fluid within the well with another fluid, cleaning the well, testing the well, transmitting hydraulic horsepower to the drill bit, fluid used for emplacing a packer, abandoning the well or preparing the well for abandonment, and otherwise treating the well or the formation.

[0003] During traditional drilling practices, mud is pumped down the drill string, through the bit and up the casing-drill string annulus to the surface. The mud’s viscosity is designed to carry drill cuttings back to surface for disposal and its density to contain the well’s natural pressure.

[0004] Drilling for oil and gas in very deep water presents problems not found in terrestrial or shallow water oil and gas exploration. One problem encountered in deep water is drilling fluid management. A drilling fluid is a fluid specially designed to be circulated through a wellbore as the wellbore is being drilled to facilitate the drilling operation. The circulation path of the drilling fluid typically extends from the drilling rig down through the drill pipe string to the bit face and back up through the annular space between the drill pipe string and wellbore face to the wellhead and/or riser, returning to the rig. In addition to the typical functions, the drilling fluid also

desirably prevents sloughing and wellbore cave-ins when drilling through water sensitive formations.

[0005] Offshore drillers have to get mud down to the bottom of the sea, where the borehole starts. To do that, they run a steel tube, called a riser, to extend the borehole from the bottom of the sea to the rig. One of the basic and most challenging problems in deep water operations is the use of the marine riser, which provides a connection between the drilling vessel and the wellhead. The riser serves as a guide for the drill pipe into the hole and as a mud return path to the vessel and also supports control cables and choke and kill lines. Floating drilling operations in deep water presently involve the use of a 21 inch outer diameter (OD) marine riser.

[0006] In shallow water drilling, a riser system, which is a separate casing rising from the sea floor to the base of a drilling ship or drilling rig, can be used to return drilling mud to a drilling ship or platform for reuse. The use of a riser is not without problems, and these problems can be exaggerated in deep water drilling projects. One such problem is weight. A 6,000-foot riser, 21 inches in diameter, holding drilling mud has been estimated to weigh from about 1,000 to 1,500 tons. It is for this reason that riserless drilling methods have been disclosed, particularly for deep water drilling, in patents such as U.S. Pat. No. 6,102,673 to Mott, et al., and U.S. Pat. No. 4,149,603 to Arnold.

[0007] Additionally, current drilling technology and required pressure ratings may limit the riser diameter to 18 $\frac{3}{4}$ inches when drilling in overpressured environments. However, because significant thicknesses of salt ranging from 1,000 to 10,000 feet may be encountered within a few thousand feet of the mudline, large-diameter hole sections are typically needed at shallow depth to accommodate the multiple casing strings required to reach the deep reservoir formations. Thus, to drill hole diameters greater than 18 $\frac{3}{4}$ inches (e.g., the 28 and 24 inch hole sections) or to reduce the costs related to conventional riser drilling, the initial, shallow portion of the well may be drilled riserless, with returns (the drilling fluid used and the formation cuttings) being discharged to the seabed.

[0008] There are a number of different types of conventional drilling fluids including compositions termed "drilling muds." Drilling muds comprise high-density dispersions of fine solids in an aqueous liquid. Because muds used in riserless drilling

are not typically circulated to the rig, the cost of “pumping and dumping” must be balanced with the benefits provided by the mud, when muds are pumped at a minimum of 1,200 gallons per minute into a well. For example, when drilling riserless, seawater alone, or blends of sea water with muds containing polymers, hydrating clays, and salts to improve inhibition, density, viscosity, and other rheological properties have been typically used. However, while these economically efficient muds may improve some properties, difficulties in drilling have still resulted from cuttings accretion and agglomeration, build up of cuttings that cover the wellhead, bit balling, and hole cleaning issues, such as swabbing, surging, and packing off, which may lead to downhole pressure issues. These drilling difficulties have been especially problematic when higher density drilling fluids are required.

[0009] Accordingly, there exists a need for a highly dispersive drilling fluid that will reduce potential problems with cuttings accretion and agglomeration, cuttings build up, bit balling, and hole cleaning.

SUMMARY OF INVENTION

[0010] In one aspect, embodiments relate to a method for drilling riserless that includes providing a drilling fluid to a drilling assembly for drilling a borehole on a seafloor, the drilling assembly comprising a drill string and a bottomhole assembly, and wherein the drilling fluid includes a brine, and a non-hydratable clay, wherein the drilling fluid is substantially free of hydrating clays, and flowing the drilling fluid and cuttings through an annulus formed by the drill string and the borehole into sea water.

[0011] In another aspect, embodiments relate to a a method for drilling riserless that includes providing a drilling fluid to a drilling assembly for drilling a borehole on a seafloor, the drilling assembly comprising a drill string and a bottomhole assembly, and wherein the drilling fluid includes a brine, attapulgite clay, and a salt of an alkali metal or alkaline earth metal wherein the drilling fluid is substantially free of hydrating clays, and flowing the drilling fluid and cuttings through an annulus formed by the drill string and the borehole into sea water.

[0012] In yet another aspect, embodiments relate to a wellbore fluid that includes an aqueous fluid, attapulgite clay, and a salt of an alkali metal or alkaline earth metal, wherein the wellbore fluid is substantially free of hydrating clays.

[0013] Other aspects and advantages of the invention will be apparent from the following description and the appended claims.

BRIEF DESCRIPTION OF DRAWINGS

[0014] FIG. 1 is a schematic view of open hole drilling according to one embodiment disclosed herein.

DETAILED DESCRIPTION

[0015] In one aspect, embodiments disclosed herein relate to dispersive drilling fluids and methods of drilling with these fluids. In particular, embodiments disclosed herein relate to drilling fluids useful in drilling a section of a borehole without a riser.

[0016] In one embodiment, a drilling fluid may include a brine and a non-hydratable clay. As used herein, "brine" is defined as including any aqueous saline solution and "non-hydratable clay" is defined as those clays which do not swell appreciably in either fresh water or salt water.

[0017] **Brine**

[0018] In various embodiments of the drilling fluid disclosed herein, the brine may include seawater, aqueous solutions wherein the salt concentration is less than that of sea water, or aqueous solutions wherein the salt concentration is greater than that of sea water. The salinity of seawater may range from about 1 percent to about 4.2 percent salt by weight based on total volume of seawater. Salts that may be found in seawater include, but are not limited to, sodium, calcium, sulfur, aluminum, magnesium, potassium, strontium, silicon, lithium, and phosphorus salts of chlorides, bromides, carbonates, iodides, chlorates, bromates, formates, nitrates, oxides, and fluorides. Salts that may be incorporated in a given brine include any one or more of those present in natural seawater or any other organic or inorganic dissolved salts. Additionally, brines that may be used in the drilling fluids disclosed herein may be natural or synthetic, with synthetic brines tending to be much simpler in constitution. In one embodiment, the density of the drilling fluid may be controlled by increasing the salt concentration in the brine (up to saturation). In a particular embodiment, a brine may include halide or carboxylate salts of mono- or divalent cations of metals, such as cesium, potassium, calcium, zinc, and/or sodium.

[0019] Clays

[0020] The drilling fluids disclosed herein may also contain a non-hydratable clay. In some embodiments, the non-hydratable clay may be a clay having a needle-like or chain-like structure. In various other embodiments, the non-hydratable clay may be selected from at least one of attapulgite and sepiolite clays. In a particular embodiment, the non-hydratable clay includes attapulgite clay. While the non-hydratable clays do not substantially swell in either fresh or salt water, they may still operate to thicken salt solutions. This thickening may be attributed to what is believed to be a unique orientation of charged colloidal clay particles in the dispersion medium, and not actual "hydration."

[0021] As the term "non-hydratable" refers to the clay's characteristic lack of swelling, i.e., measurable volume increase, in the presence of salt water, a given clay's swellability in sea water may be tested by a procedure described in an article by K. Norrish, published as "The swelling of Montmorillonite," *Disc. Faraday Soc.* vol. 18, 1954 pp. 120-134. This test involves submersion of the clay for about 2 hours in a solution of deionized water and about 4 percent sodium chloride by weight per volume of the salt solution. Similarly, a given clay's swellability in fresh water may be tested by an analogous procedure in which the sodium chloride is excluded. A "non-hydratable" clay is defined in one embodiment as one that, under this test, swells less than 8 times by volume compared with its dry volume. In another embodiment, a non-hydratable clay exhibits swelling on the order of less than 2 times; less than 0.3 times in another embodiment; and less than 0.2 times in yet another embodiment.

[0022] In further embodiments, the drilling fluids disclosed herein may be substantially free of hydrating clays. As used herein, "hydrating clays" is defined as those clays which swell appreciably (i.e., increase their volume by an amount of at least about 8 times) in either fresh water or salt water, and "substantially free" is defined as an amount that does not significantly affect dispersibility. Hydrating clays may include those clays which swell appreciably in contact with fresh water, but not when in contact with salt water, include, for example, clays containing sodium montmorillonite, such as bentonite. Many hydrating clays have a sheet- or plate-like structure.

[0023] Salts

[0024] In various embodiments, the drilling fluid disclosed herein may also contain at least one additional salt, including any salt that may be incorporated in brines, as disclosed herein. In particular embodiments, at least one of sodium chloride, calcium chloride, potassium chloride, and sodium carbonate may be incorporated in the drilling fluids disclosed here. In one embodiment, the at least one additional salt may be incorporated into the drilling fluid disclosed herein in an amount ranging from about 0.5 weight percent to salt saturation.

[0025] Additives

[0026] The wellbore fluids disclosed herein may optionally contain various additives, depending on the end use of the fluid. For example, weighting agents, deflocculants, and combinations thereof may be added to the fluid compositions disclosed herein for additional functional properties. The addition of such agents should be well known to one of skill in the art of formulating drilling fluids and muds. However, it should be noted that the addition of such agents should not adversely interfere with the properties associated with the mud's ability to disperse cuttings as disclosed herein.

[0027] Weighting agents or density materials suitable for use in the fluids disclosed herein include, for example, galena, hematite, magnetite, iron oxides, ilmenite, barite, siderite, celestite, dolomite, calcite, and the like. The quantity of such material added, if any, depends upon the desired density of the final composition. Typically, weight material is added to result in a drilling fluid density of up to about 19 pounds per gallon in one embodiment; and ranging from 9.5 to 14 pounds per gallon in another embodiment.

[0028] Deflocculants or thinners that may be used in the drilling fluids disclosed herein include, for example, lignosulfonates, modified lignosulfonates, polyphosphates, tannins, and low molecular weight water soluble polymers, such as polyacrylates. Deflocculants are typically added to a drilling fluid to reduce flow resistance and control gelation tendencies. In a particular embodiment, a deflocculant may be desirable when a drilling fluid is formed from a heavier mud diluted with sea water. TANNATHIN[®], an oxidized lignite, is an example of a deflocculant which is available from M-I L.L.C. (Houston, Texas).

77680-75

[0029] Formulations

[0030] In one embodiment, the drilling fluid may be formulated to have a density range from about 9 to 14 pounds per gallon. The drilling fluid may be initially formulated to have the desired formulation. Alternatively, the drilling fluid may be formed from a concentrated mud, such as a 16 pound per gallon mud, or heavier which is be blended with a brine prior to use to the desired formulation. Those having ordinary skill in the art will appreciate that other densities may be used as desired. When blended from a mud and a brine, the mud may optionally contain a salt, such as a salt of an alkali metal or alkaline earth metal. In one embodiment, the drilling fluid may have a pH greater than about 6. In another embodiment, the drilling fluid may have a pH ranging from about 7.5 to 12. The pH of the drilling fluid may be tailored with the addition of acidic or basic additives, as recognized by one skilled in the art. For example, caustic soda and citric acid may be used to increase or decrease the pH of a fluid, respectively.

[0031] Method of Drilling

[0032] When drilling from a vessel or floating platform, the upper portion of the well is often drilled by open hole drilling in that no conduit is provided for the drilling fluid/cutting returns to flow to the platform. As shown in FIG. 1, to drill the initial upper portion of the well 10, a drill string 14 typically extends unsupported from a vessel or platform 12 through the water to the seafloor 18 without a riser. In more detail, first an outer casing 20, known as "structural casing," typically having a diameter of up to 30-inches or 36-inches, is installed in the uppermost section of the well, with a low-pressure wellhead housing (not shown separately) connected thereto. In soft formations, the structural casing 20 may be jetted into place. In this process, a drilling assembly that includes the drill string 14 and a bottom hole assembly (BHA) (not shown separately), and casing 20 is lowered to the seafloor via the drill string 14. The BHA includes a drill bit 16, and may also include other components such as, drill collars and a downhole motor (not shown separately). The bit 16 is positioned just below the bottom end of the structural casing 20 and is sized to drill a borehole 22 with a slightly smaller diameter than the diameter of the casing 20. As the borehole 22 is drilled, the structural casing 20 moves downwardly with the BHA. The weight of the structural casing 20 and BHA drives the casing 20 into the sediments. The

structural casing 20, in its final position, may extend downwardly to a depth of 150 to 400 feet, depending upon the formation conditions and the final well design. After the structural casing 20 is in place, it may be released from the drill string 14 and BHA. The drill string 14 and BHA may be tripped back to the platform, or alternatively, may be lowered to drill below the structural casing.

[0033] Alternatively, the structural casing 20 may be installed in a two-step process. First, a borehole larger than the structural casing is drilled. Then the structural casing 20 is run into the borehole 22 and cemented into place. Typically, the low-pressure wellhead housing (not shown separately) is connected to the upper end of the structural casing 20 and installed at the same time, such that the structural casing 20 extends below the seafloor with the low-pressure wellhead housing above the seafloor.

[0034] Once the structural casing 20 and the low-pressure wellhead housing are installed, the bit 16 on the drill string 14 drills downwardly below the structural casing 20 to drill a new borehole section using open hole drilling for an intermediate casing 24, known as "conductor casing," which may be, for example, 20-inches in diameter. Thus, the structural casing 20 guides the BHA as it begins to drill the conductor casing 24 interval. After the borehole section for the conductor casing 24 is drilled, the BHA is tripped to the surface. Then conductor casing 24, with a high-pressure wellhead housing connected to its upper end, and a float valve disposed in its lower end (not shown separately), is run into the drilled conductor borehole section extending below the structural casing 20. The conductor casing 24 is cemented into place in a well known manner, with the float valve preventing cement from flowing upwardly into the conductor casing after cement placement. The conductor casing 24 generally may extend downwardly to a depth of 1,000 to 3,000 feet below the seafloor, depending on the formation conditions and the final well design. The high-pressure wellhead housing (not shown separately) may engage the low-pressure wellhead housing (not shown separately) to form the subsea wellhead, thereby completing the riserless portion of the drilling operations. Installation of a subsea blowout preventer (BOP) stack may be conveyed down to the seafloor by a riser and latched onto the subsea wellhead housing for subsequent riser drilling.

[0035] During the open hole drilling shown in FIG. 1, drilling fluid flows through the drill string 14 and out of the drill bit 16 as shown by downward arrows 26. The flow

of the drilling fluid continues through the annulus between the borehole 22 and the drilling assembly 14, 16. As the drilling fluid flows through this annulus, it may carry drilled cuttings through the borehole, indicated by upward arrows 28 and may exit the well to be dispersed into the sea, as indicated by arrows 30. Therefore, in open hole drilling the returns, i.e. the drilling fluid, cuttings, and well fluids, are discharged onto the seafloor and are not conveyed to the surface.

[0036] EXAMPLE

[0037] The following examples were used to test the effectiveness of the drilling fluids disclosed herein in dispersing cuttings.

[0038] Drilling muds were formulated having the following components, all of which are commercially available, as shown below in Table 1. M-I GEL[®] is an example of a bentonite clay, SALT GEL[®] is an example of an attapulgite clay, TANNATHIN[®] is a lignite, and DUOVIS[®] is a xanthan gum, all of which are commercially available from M-I L.L.C. (Houston, Texas).

Table 1: 16 ppg Mud Formulations

	A	B	C	D	E	F	G	H	I	J
Tap water (bbl)	0.699	0.697	0.691	0.706	0.691	0.691	0.691	0.691	0.691	0.691
M-I GEL (ppb)	20.0	-	-	-	-	-	-	-	-	-
NaCl (ppb)	-	-	7.48	7.64	7.48	7.48	7.48	7.48	7.48	32.43
SALT GEL (ppb)	-	20.0	20.0	-	20.0	20.0	20.0	20.0	20.0	20.0
DUOVIS (ppb)	-	-	-	2.0	-	-	-	-	-	-
Caustic Soda (ppb)	0.50	0.50	0.75	0.5	0.75	0.75	3.0	0.75	0.75	0.75
TANNATHIN (ppb)	2.0	0.10	2.0	-	1.25	1.25	1.25	0.75	1.25	3.0
Barite (ppb)	405.0	407.4	399.97	415.4	399.97	399.97	399.97	399.97	399.97	379.51
Citric Acid (ppb)	-	-	-	-	-	2.0	-	-	-	-
Soda ash (ppb)	-	-	-	-	-	-	-	-	3.0	-

[0039] The various mud formulations were then blended with sea water, and their rheological properties were determined using a Fann Model 35 Viscometer, available from Fann Instrument Company. The muds were then subjected to dispersion testing, where 20 grams of shale, dried for 16 hours at 200°F and sized to -6/+20 mesh, was added to the mud blends and hot-rolled for 16 hours at 150°F. Seawater was used as a blank. After hot-rolling, the samples were cooled. An 80 mesh screen was used to recover un-dispersed shale. A percent recovery can be determined by comparing the amount of shale recovered to the initial 20 grams of shale used. A lower percent recovery indicates greater dispersion of the shale by the fluid. The results are shown below in Tables 2a and 2b.

Table 2a: Dispersion Test

	Sample Number							
	1	2	3	4	5	6	7	8
Mud Formulation	-	A	A	A	A	B	C	D
16 ppg Mud (bbl)	-	0.128	0.262	0.396	0.53	0.53	0.53	0.53
Seawater (bbl)	1.0	0.872	0.738	0.604	0.47	0.47	0.47	0.47
Mud Weight	-	9.5	10.5	11.5	12.5	12.5	12.5	12.5
Rheology Temperature (°F)	-	120	120	120	120	120	120	120
600 rpm	-	6	13	25	44	33	28	34
300 rpm	-	4	10	21	36	29	24	21
200 rpm	-	3	9	20	34	23	21	17
100 rpm	-	2	8	18	30	20	19	12
6 rpm	-	2	5	12	21	15	3	3
3 rpm	-	1	4	12	21	15	3	2
Plastic Viscosity (cps)	-	2	3	4	8	4	4	13
Yield Point (lbs/100 ft ²)	-	2	7	17	28	25	20	8
10 Second Gel	-	2	6	11	22	17	17	3
10 Minute Gel	-	2	11	22	47	22	37	10
pH	-	7.7	7.8	8.0	8.1	9.3	9.36	9.69
Recovery (%)	3.4	10.3	85.8	87.8	89.0	69.80	44.65	76.0

Table 2b: Dispersion Test

	Sample Number							
	9	10	11	12	13	14	15	16
Mud Formulation	E	E	E	F	G	H	I	J
16 ppg Mud (bbl)	0.128	0.262	0.396	0.128	0.262	0.396	0.396	0.396
Seawater (bbl)	0.872	0.738	0.604	0.872	0.738	0.604	0.604	0.604
Mud Weight	9.5	10.5	11.5	11.5	11.5	11.5	11.5	11.5
Rheology Temperature (°F)	120	120	120	120	120	120	120	120
600 rpm	7	12	16	13	22	15	20	17
300 rpm	5	8	12	9	16	10	16	12
200 rpm	4	6	10	8	14	8	14	10
100 rpm	3	5	8	6	12	7	12	9
6 rpm	2	2	5	5	9	5	10	6
3 rpm	2	2	4	5	9	5	10	6
Plastic Viscosity (cps)	2	4	4	4	6	5	4	5
Yield Point (lbs/100 ft ²)	3	4	8	5	10	5	12	8
10 Second Gel	3	3	5	6	6	3	8	6
10 Minute Gel	3	5	11	22	12	5	15	10
pH	8.6	8.8	8.9	7.2	12.0	9.3	9.7	8.2
Recovery (%)	6.05	24.75	51.55	50.8	32.7	63.6	59.5	72.4

[0040] From the results shown in Tables 2a and 2b, a comparison of Samples 9-11 (Mud E) to Samples 2-5 (Mud A) shows increased dispersion of the shale into the drilling fluid containing attapulgite clay over that containing bentonite clay. Similarly, a comparison of Samples 7 (Mud C) to Sample 8 (Mud D) shows increased dispersion of the shale into the drilling fluid containing attapulgite over that containing polymer. Additionally, dispersion may be further increased at higher pHs, as shown by comparing Samples 12-16 (Muds F-J) to each other, and upon the addition of a salt, as shown by comparing Samples 6 (Mud B) to Sample 7 (Mud C).

[0041] Advantageously, embodiments disclosed herein may provide for a drilling fluid that may be used in open hole drilling. The fluids disclosed herein may provide the rheological properties needed for drilling without a riser. Additionally, by increasing the amount of dispersion of cuttings into the fluids and subsequently into the sea water, the fluids may at least reduce cuttings accretion and agglomeration, build up of cuttings that cover the wellhead, bit balling, and hole cleaning issues, such as swabbing, surging, and packing off, which may lead to pressure issues.

[0042] While the invention has been described with respect to a limited number of embodiments, those skilled in the art, having benefit of this disclosure, will appreciate that other embodiments can be devised which do not depart from the scope of the invention as disclosed herein. Accordingly, the scope of the invention should be limited only by the attached claims.

77680-75

CLAIMS:

1. A method for drilling riserless, comprising:
providing a drilling fluid to a drilling assembly for drilling a borehole on a seafloor, the drilling assembly comprising a drill string and a bottomhole assembly, and wherein the drilling fluid comprises:
a brine; and
a non-hydratable clay, wherein the drilling fluid is free of hydrating clays; and
flowing the drilling fluid and cuttings through an annulus formed by the drill string and the borehole into sea water.
2. The method of claim 1, further comprising:
inserting a casing into the borehole.
3. The method of claim 2, wherein the casing is inserted in the borehole as the borehole is drilled.
4. The method of claim 2, wherein the casing is inserted in the borehole after the borehole is drilled.
5. The method of claim 1, wherein the non-hydratable clay comprises at least one of attapulgite and sepiolite clays.
6. The method of claim 1, wherein the drilling fluid density ranges from about 9.0 to 14 ppg.
7. The method of claim 1, wherein the drilling fluid has a pH ranging from about 7.5 to 12.
8. The method of claim 1, wherein the drilling fluid further comprises at least one of a weighting agent, a deflocculant, a fluid loss control agent, and combinations thereof.
9. The method of claim 1, wherein the drilling fluid further comprises a salt of an alkali metal or alkaline earth metal.

77680-75

10. A method of drilling a formation, comprising:

providing a drilling fluid to a drilling assembly for drilling a borehole on a seafloor, the drilling assembly comprising a drill string and a bottomhole assembly, and wherein the drilling fluid comprises:

a brine;

attapulgate clay; and

a salt of an alkali metal or alkaline earth metal, wherein the mud is free of hydrating clays; and

flowing the drilling fluid and cuttings through an annulus formed by the drill string and the borehole into sea water.

11. The method of claim 10, wherein the drilling fluid density ranges from about 9.0 to 14 ppg.

12. The method of claim 10, wherein the drilling fluid has a pH ranging from about 7 to 12.

13. The method of claim 10, wherein the drilling fluid further comprises at least one of a weighting agent, a deflocculant, a fluid loss control agent, and combinations thereof.

14. A wellbore fluid, comprising:

an aqueous fluid;

attapulgate clay; and

a salt of an alkali metal or alkaline earth metal, wherein the wellbore fluid is free of hydrating clays.

15. The wellbore fluid of claim 14, wherein the non-hydratable clay comprises at least one of attapulgate and sepiolite clays.

16. The wellbore fluid of claim 14, wherein the drilling fluid density ranges from about 9.0 to 14 ppg.

17. The wellbore fluid of claim 14, wherein the drilling fluid has a pH ranging from about 7 to 12.

77680-75

18. The wellbore fluid of claim 14, further comprising:

at least one of a weighting agent, a deflocculant, and combinations thereof.

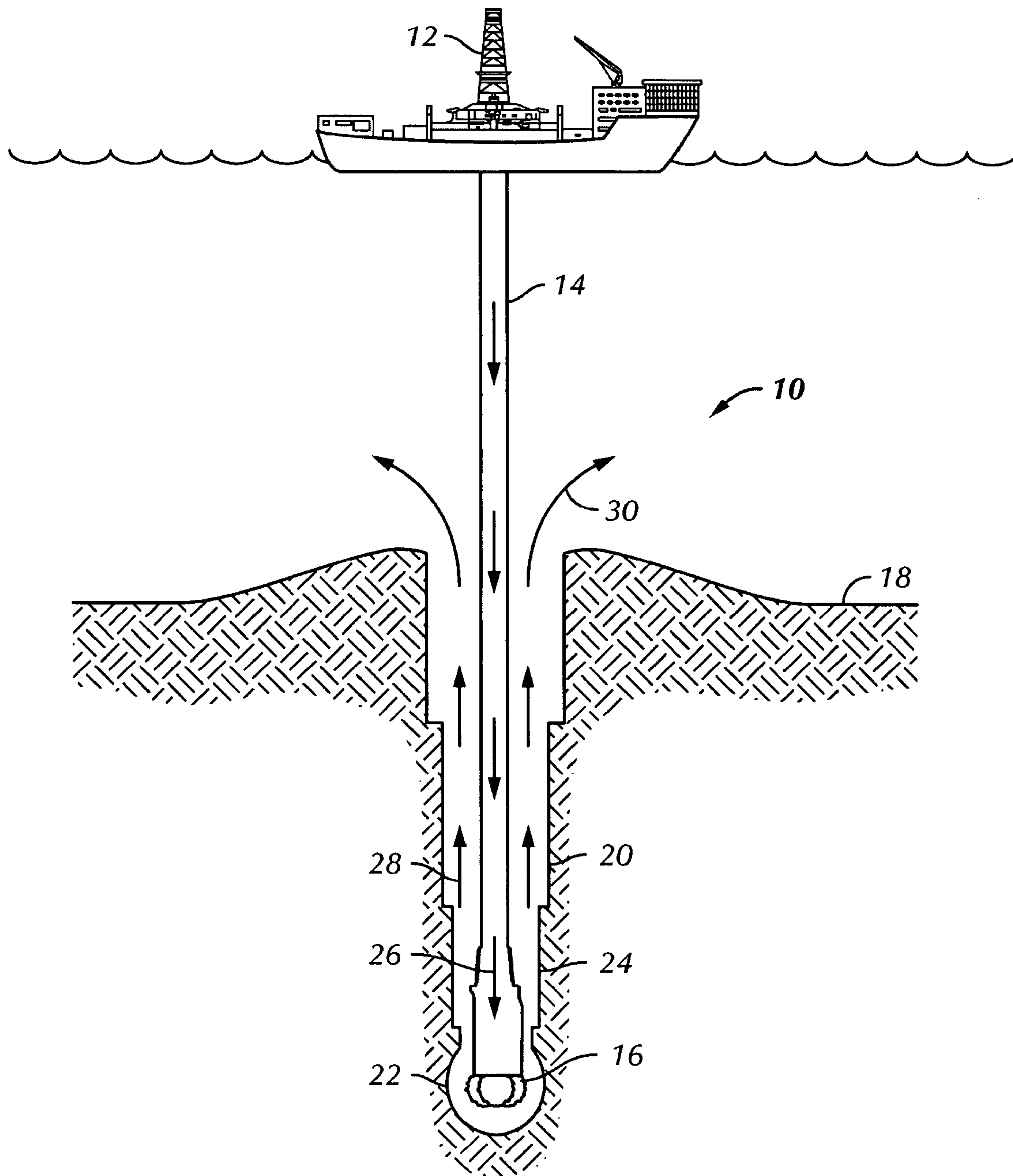

FIG. 1

