



- (51) International Patent Classification: Not classified
  - (21) International Application Number: PCT/EP2011/058604
  - (22) International Filing Date: 26 May 2011 (26.05.2011)
  - (25) Filing Language: English
  - (26) Publication Language: English
  - (30) Priority Data: 201010189908.3 28 May 2010 (28.05.2010) CN
  - (71) Applicant (for all designated States except US): **BSH BOSCH UND SIEMENS HAUSGERÄTE GMBH** [DE/DE]; Carl-Wery-Str. 34, 81739 München (DE).
  - (72) Inventors; and
  - (75) Inventors/Applicants (for US only): **DING, Yulei** [CN/CN]; NO.208,yao xin da dao,xingang jingji development zone, Nanjing, Jiangsu 210046 (CN). **MA, Jingdong** [CN/CN]; No. 1 Ximenzi Lu Chuzhou Anhui Province P. R. China, Chuzhou, Anhui 239016 (CN). **YANG, Zhenyu** [CN/CN]; No. 1 Ximenzi Road, Chuzhou, Anhui 239016 (CN). **ZHAO, Defei** [CN/CN]; Li Jingjing forward to Zhao, Dawang bridewell of Chuzhou public security bureau, Chuzhou, Anhui 239000 (CN).
  - (74) Common Representative: **BSH BOSCH UND SIEMENS HAUSGERÄTE GMBH**; 83 01 01, 81701 München (DE).
  - (81) Designated States (unless otherwise indicated, for every kind of national protection available): AE, AG, AL, AM, AO, AT, AU, AZ, BA, BB, BG, BH, BR, BW, BY, BZ, CA, CH, CL, CN, CO, CR, CU, CZ, DE, DK, DM, DO, DZ, EC, EE, EG, ES, FI, GB, GD, GE, GH, GM, GT, HN, HR, HU, ID, IL, IN, IS, JP, KE, KG, KM, KN, KP, KR, KZ, LA, LC, LK, LR, LS, LT, LU, LY, MA, MD, ME, MG, MK, MN, MW, MX, MY, MZ, NA, NG, NI, NO, NZ, OM, PE, PG, PH, PL, PT, RO, RS, RU, SC, SD, SE, SG, SK, SL, SM, ST, SV, SY, TH, TJ, TM, TN, TR, TT, TZ, UA, UG, US, UZ, VC, VN, ZA, ZM, ZW.
  - (84) Designated States (unless otherwise indicated, for every kind of regional protection available): ARIPO (BW, GH, GM, KE, LR, LS, MW, MZ, NA, SD, SL, SZ, TZ, UG, ZM, ZW), Eurasian (AM, AZ, BY, KG, KZ, MD, RU, TJ, TM), European (AL, AT, BE, BG, CH, CY, CZ, DE, DK, EE, ES, FI, FR, GB, GR, HR, HU, IE, IS, IT, LT, LU, LV, MC, MK, MT, NL, NO, PL, PT, RO, RS, SE, SI, SK, SM, TR), OAPI (BF, BJ, CF, CG, CI, CM, GA, GN, GQ, GW, ML, MR, NE, SN, TD, TG).
- Published:**
- without international search report and to be republished upon receipt of that report (Rule 48.2(g))



WO 2011/147896 A2

(54) Title: REFRIGERATION APPLIANCE AND LOW-PRESSURE STORAGE UNIT THEREFOR

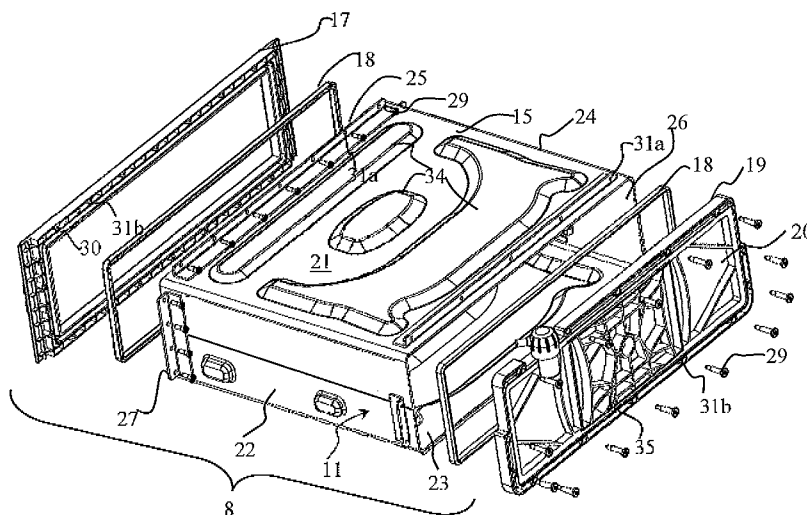

Figure 4

(57) Abstract: The present invention relates to a low-pressure storage unit for a refrigeration appliance and a refrigeration appliance having the same. The low-pressure storage unit comprises a first member (11) and a second member (16, 17) which forms different parts of a wall of the storing chamber (32) and are constructed independently from each other and then connected together, as well as a sealing element (18) connecting the first member (11) with the second member (16, 17) in an air-tightness manner. The securing unit comprises a hole (31a, 31b) that is provided in at least one of the first member (11) and the second member (16, 17), and a securing member (29) inserted into the hole (31a, 31b), wherein the securing unit is constructed in such a way that the interior of the storing chamber (32) is not in fluid communication with the exterior thereof.

## REFRIGERATION APPLIANCE AND LOW-PRESSURE STORAGE UNIT THEREFOR

### FIELD OF THE INVENTION

5

The present invention relates to a low-pressure storage unit for a refrigeration appliance and to a refrigeration appliance having the low-pressure storage unit.

### BACKGROUND

10

Such a refrigeration appliance is well-known in the prior art, in which refrigeration appliance items can be stored in a low-pressure environment. Said refrigeration appliance generally comprises an evacuable storing chamber, wherein by evacuating gas in the storing chamber off, the air content in the storing chamber is reduced such that the hyperoxidation of foods is weakened to prolong the storing period and quality of the foods.

15

In a refrigeration appliance disclosed by Chinese patent application CN 103243942A and having an evacuable storing chamber (also called as "a low-pressure chamber" or "a vacuum chamber"), a main body of the low-pressure chamber having a food access opening is constructed to have: an external contour, which is formed by resin in a box shape and forms the food access opening, a glass plate made of tempered glass, and a plate-shaped member made of metal, which member extends along a plurality of wall faces of the external contour. In this way, because the external contour that is easy to deform is supported by the plate-shaped member made of metal, the deformation of the external contour under pressure is reduced, such that the air tightness at the access site between the external contour and the low-pressure chamber door is improved. However, when the endured pressure difference is large, the external contour made of resin is easy to deform and thus the air tightness of the low-pressure

20

25

chamber is weakened. Although a larger thickness can be adopted to prevent the wall of the storing chamber from deforming, in the case that the external contour made of resin is of a box shape, the larger thickness reduces the thermal conductive effect between the exterior and the interior of the storing chamber, and in this case the cabinet molding process is more complex and the defect rate of finished articles is high.

Furthermore, the glass plate is supported tightly on an upper opening of the external contour made of plastic by a ring-shaped gasket, wherein the ring-shaped gasket is provided such that it covers the side ends of the glass member, an opening part is formed in the upper of the external contour made of resin, a step is formed on the opening part, and the ring-shaped gasket is placed on the step. The ring-shaped gasket is elastic such that it is adapted for maintaining the tightness between the glass plate and the opening for supporting the glass plate. Therefore, the gasket is deformed due to the deadweight of the glass plate and the pressure difference between the interior and the exterior, such that a sealing is formed between the glass plate and the external contour made of resin. When the refrigeration appliance is acted by an external force, the positions of the glass plate and the external contour made of resin are possibly variable, such that the sealing between them becomes not reliable.

20

Therefore, it is desired to improve the traditional low-pressure storage unit.

## **SUMMARY OF THE INVENTION**

It is an objective of the present invention to solve at least one of the above-mentioned problems, such that the independently constructed members of the low-pressure storage unit can be more reliably secured without degrading the air tightness of the low-pressure storage unit.

Therefore, on the one hand, the present invention relates to a low-pressure storage unit for a refrigeration appliance, wherein the low-pressure storage unit defines an evacuable storing chamber, and the low-pressure storage unit comprises: a first member, which first member forms a part of a wall of the storing chamber; a second member, which second member is constructed independently from the first member and forms a part of the wall of the storing chamber, and a sealing element for connecting the first member with the second member in an airtight manner; characterized in that the low-pressure storage unit further comprises at least one securing unit for securing the first member and the second member, wherein the securing unit comprises a hole that is at least provided in at least one of the first member and the second member, and a securing member inserted into the hole, wherein the securing unit is constructed in such a way that the interior of the storing chamber is not in fluid communication with the exterior thereof.

Therefore, by use of the securing unit comprising the hole provided on the first member and/or the second member and the securing member inserted into the hole, the independently constructed first and second members can be reliably secured. On the other hand, although the hole is provided, the securing unit is provided such that the storing chamber is not in fluid communication with fluid from the exterior. Therefore, the hole has no influence on the air tightness of the low-pressure storage unit. That is, no additional sealing measure needs be adopted for the hole of the securing unit.

Other individual features or features which are combined with other features so as to be considered as belonging to the characteristic of the present invention will be described in the attached claims.

According to a preferred embodiment of the present invention, the hole is entirely located inside or outside the storing chamber.

According to a preferred embodiment of the present invention, the hole is isolated from the storing chamber.

5 According to a preferred embodiment of the present invention, the first member and the second member each comprise a first connecting portion and a second connecting portion, both of which portions are located outside the storing chamber, and the securing unit is provided on the first connecting portion and the second connecting portion.

10 According to a preferred embodiment of the present invention, at least one of the first connecting portion and the second connecting portion is formed integrally on a corresponding one of the members.

15 According to a preferred embodiment of the present invention, the first member comprises at least one mounting plate secured to the first member and forming the first connecting portion, and the mounting plate comprises a foot connected to an outer surface of the first member and an extension folding from the foot and then extending outwardly to form the first connecting portion. In a preferred embodiment, the mounting plate has an L-shaped cross section.

20

According to a preferred embodiment of the present invention, the securing unit is constructed to provide a pretension force for the first member, the second member and the sealing element.

25 In an embodiment that is particularly easily carried out, the securing member is a screw. In an alternative embodiment, the securing member comprises a rod-shaped part formed integrally on the first member and/or the second member.

According to a preferred embodiment of the present invention, the first member and

the second member are made of different materials whose elastic ratios are different from each other respectively.

According to a preferred embodiment of the present invention, the first member is  
5 made of metal, such as steel or aluminum.

According to a preferred embodiment of the present invention, the second member is made of plastic.

10 According to a preferred embodiment of the present invention, the first member forms at least a majority of a plurality of interconnected walls of the storing chamber. This facilitates improving the pressure enduring capability of the low-pressure storage unit.

According to a preferred embodiment of the present invention, the first member is of a  
15 box-structure and has at least one opening, and the second member is secured to the first member along the opening.

According to a preferred embodiment of the present invention, the low-pressure storage unit comprises a plurality of securing units that are spaced apart from one  
20 another, and these securing units are provided around the opening and form at least one frame surrounding the opening.

According to a preferred embodiment of the present invention, the low-pressure storage unit comprises a door, wherein said at least one opening comprises a front  
25 opening that can be selectively opened and closed by the door, and the second member has a close-loop-frame shape and is connected to the entire edge of the front opening such that a connection frame is formed to abut with the door.

According to a preferred embodiment of the present invention, the hole provided in the

second member is a blind hole, one end of which is opened to a rear surface of the second member.

According to a preferred embodiment of the present invention, the second member has  
5 a planar abutting surface for abutting with the door.

According to a preferred embodiment of the present invention, the second member is  
of a generally plate-shaped structure, and forms an entire wall of the storing chamber,  
and the hole is located on the peripheral region of the second member.

10

According to a preferred embodiment of the present invention, the second member has  
a ring-shaped groove for receiving at least a part of the sealing element, and the  
securing unit is located on the outer periphery of the ring-shaped groove.

15 On the other hand, the present invention relates to a refrigeration appliance (1),  
comprising a low-pressure storage unit claimed as above.

The configuration of the present invention and other objectives and beneficial effects  
thereof will be well understood by description of preferred embodiment in accompany  
20 of the drawings.

## **BRIEF DESCRIPTION OF THE DRAWINGS**

As a part of the description and in order to provide further explanation of the present  
25 invent, the drawings illustrate preferred embodiments of the present invention, and  
together with the description are used to explain the principle of the present invention.  
In the drawings:

Figure 1 shows a schematic perspective view of a refrigeration appliance according to

a preferred embodiment of the present invention, wherein a door of the refrigeration appliance is not shown;

Figure 2 shows a schematic assembled perspective view of a low-pressure storage unit according to a preferred embodiment of the present invention;

Figure 3 is a schematic perspective view, showing that the low-pressure storage unit according to the preferred embodiment of the present invention is opened;

Figure 4 is a schematic exploded view, showing a main body of the low-pressure storage unit according to the preferred embodiment of the present invention; and

Figure 5 is a schematic partial cross-sectional view taken in a direction A-A in figure 2.

## DETAILED DESCRIPTION OF THE INVENTION

As shown in figure 1, a refrigeration appliance 1 comprises a thermally insulated cabinet 2, which cabinet 2 includes an outer shell 2a, an inner shell 2b and a thermal insulation layer (not shown) therebetween. The cabinet 2 defines a plurality of thermally insulated storage compartments 3, 4 and 5 to store items such as foods. In the present embodiment, these storage compartments are an upper refrigeration compartment 3, a lower freezing compartment 5 and a preservation compartment 4 which is located between the upper and lower compartments and is maintained at a temperature of slightly higher than zero Degree Celsius. These storage compartments 3, 4 and 5 can be closed by respective doors (not shown).

It should be understood that the present invention is not limited by the specific arrangement of the storage compartments of the refrigeration appliance. The present invention can be applied for other types of refrigeration appliance, such as a

refrigerator having refrigerating and freezing compartments arranged one above the other, a side-by-side combination refrigerator as well as a refrigerator having a drawer-typed door and/or a French door refrigerator or the like.

5 The refrigeration appliance 1 has a close-looped evaporative refrigeration system. The refrigeration system comprises at least a compressor (not shown), a condenser (not shown), a throttling device (not shown) and an evaporator (not shown). Since this kind of refrigeration system is well-known in the prior art, its detailed explanation is omitted here.

10

The refrigeration appliance 1 is provided with a low-pressure storage unit 7, having an evacuable storing chamber 32, and an evacuation device (not shown) for evacuating gas out of the storing chamber 32. The evacuation device can comprise a vacuum pump and a pipeline (not shown) connecting between the vacuum pump and the  
15 low-pressure storage unit 7.

In the present embodiment, the low-pressure storage unit 7 is provided in the preservation compartment 4. The low-pressure storage unit 7 is located at a bottom of the preservation compartment 4, and is supported on a bottom wall of the preservation  
20 compartment 4. In the present embodiment, a preservation container 6 is provided above the low-pressure storage unit 7, which preservation container has a higher humidity and is adapted for storing foods such as vegetables. It should be understood that, in an alternative embodiment, the low-pressure storage unit 7 can be provided in other storage compartments, such as the refrigerating compartment 3 or a variable  
25 compartment whose temperature zone can be changed between a refrigerating temperature zone and a freezing temperature zone.

Figurer 2 is a schematic assembly perspective view showing the low-pressure storage unit 7 according to a preferred embodiment of the present invention. Figure 3 is a

schematic perspective view showing that the low-pressure storage unit 7 according to the preferred embodiment of the present invention is opened. As shown in figures 2 and 3, in this embodiment, the low-pressure storage unit 7 is generally in the form of a flat rectangular parallelepiped and comprises a main body 8 being opened at one end and a drawer-typed container 9 which is movably received in the main body 8.

The main body 8 defines a flat receiving space having a front opening. The drawer-typed container 9, at its front wall, is formed with a door 10 for closing the front opening of the main body 8. A tray-shaped container body 12 is connected at a rear side of the door 10 for storing items. The main body 8 is received and secured in the cabinet 2. It is preferable that the main body 8 is detachably secured in the preservation compartment 4. A user can draw out the draw-typed container 9 to have access to the items in the low-pressure storage unit 7.

The main body 8 and the door 10 have widths which each are slightly less than the width of the preservation compartment 4. Thus it is ensured that the main body 8 and the door 10 can be inserted into the preservation compartment 4 or be pulled out of the preservation compartment 4. Therefore, gaps can be formed between both sides of the low-pressure storage unit 7 and the inner shell 2b of the preservation compartment 4 respectively. In order to shield these gaps, the low-pressure storage unit 7 can comprise a deformable gap shielding member 50 which is provided at the front end of the main body 8.

The low-pressure storage unit 7 has a housing 40 which is constituted by the main body 8 and the door 10 of the drawer-typed container 9. The housing 40 defines the evacuable storing chamber 32, wherein the tray-shaped container body 12 is located in the storing chamber 32. In the present embodiment, the storing chamber 32 is essentially formed by the receiving space of the main body 8.

When the storing chamber 32 is closed by the door 10 and the evacuation device is switched on, gas in the storing chamber 32 is evacuated off and the storing chamber 32 is in a low-pressure state. According to a preferred embodiment of the present invention, after the evacuation procedure is completed, the storing chamber 32 has a  
5 pressure therein, which pressure is between one standard atmospheric pressure and the absolute vacuum (for example, the absolute vacuum being less than 690 millibars). Because the gas pressure in the storing chamber 32 is less than one standard atmospheric pressure, this chamber can also be called as "a vacuum chamber" by the skilled in the art. In the present embodiment, the storing chamber 32 has a volume of  
10 about 20 L.

A sealing element (not shown) can be provided at the front end of the main body 8 and/or at the door 10, such that there is a gas tightness engagement formed between the main body 8 and the door 10 after the drawer-typed container 9 is completely  
15 closed. Therefore, gas is prevented from entering into the storing chamber 32 via the engagement site between the main body 8 and the door 10.

A telescopic guide unit 14 is provided between the drawer-typed container 9 and the main body 8, such that the drawer-typed container 9 can be smoothly pulled out of the  
20 main body 8 or pushed into the main body 8.

The door 10 is provide with a gas filling passage (not shown), which gas filling passage fluidly communicates with the interior and exterior of the storing chamber 32, and a gas filling valve (not shown) for opening or closing the gas filling passage. When the gas  
25 filling passage is opened by the gas filling valve, gas from the exterior can enter into the storing chamber 32 via the gas filling passage such that the low-pressure state of the storing chamber 32 is released.

The door 10 is provided with a handle 13 at the front end. The user can operate the

drawer-typed container 9 by the handler 13. In one preferred embodiment, the gas filling valve is provided in such a way that it is associated with the handle 13. That is, when the handle 13 is operated, the gas filling valve is opened such that the storing chamber 32 fluidly communicates with the exterior. Therefore, gas can enter into the storing chamber 32 such that the low-pressure state of the storing chamber 32 is released. In an alternative embodiment, the gas filling valve can be provided independently from the handle 13. For example, the door 10 is provided with a button thereon. The gas filling valve is opened by pressing the button. Then, the user can operate the handle 13 to open the door 10.

10

The door 10, constituting the front wall of the storing chamber 32, is made of plastic which is easily molded, because some complex structures such as the gas filling valve and the handler 13 and so on will be formed. In the present embodiment, the door 10 is made of ABS resin (acrylonitrile butadiene styrene).

15

The inner surface of the door 10 is exposed to the storing chamber 32, and the outer surface of the door constitutes a part of the external contour of the low-pressure storage unit 7 so as to form a part of the wall of the storing chamber 32. When the storing chamber 32 is in the low-pressure state, the door 10 must endure a pressure difference between the interior and the exterior. However, the tray-shaped container body 12 endures no pressure because it is located in the storing chamber 32.

20

Therefore, the door 10 has a thickness which is larger than the tray-shaped container body 12. In the present embodiment, the thickness of the door 10 is 6 millimeters, and the tray-shaped container body 12 can have a thickness of about 1 to 2 millimeters.

25

Figure 4 is a schematic exploded perspective view showing the main body 8 according to a preferred embodiment of the present invention. As shown in figures 2 and 3 by combination with figure 4, the main body 8 comprises a box-shaped box body 11 which is opened at front and rear ends, a rear cover 16 which is secured at the rear end of the

box body 11 to close a rear opening 26 of the box body 11, and a front jointing unit 17, which is secured at an edge of a front opening 25 of the box body 11.

5 A sealing element 18 is provided between the box body 11 and the rear cover 16 as well as between the box body 11 and the front jointing unit 17 respectively, such that the box body 11 forms a gas tightness engagement with the rear cover 16 and a gas tightness engagement with the front jointing unit 17 respectively.

10 In the present embodiment, the box body 11 comprises a top wall 21, a bottom wall 23, left and right side walls 22 which are connected between the top wall 21 and the bottom wall 32. The top, bottom, left and right side walls are made of metal having a larger material strength. The box body 11 constitutes a main part of the housing 40. In the present embodiment, the top wall 21, the bottom wall 23 and the left and right side walls 22, all of which are made of metal, are exposed at their inner sides to the storing chamber 32 respectively. Outer surfaces of these walls constitute a part of the external contour of the low-pressure storage unit 7, and constitute a majority of the upper wall, the lower wall and two side walls of the storing chamber 32. The front jointing unit 17 is also exposed at its inner side to the storing chamber 32. Therefore, it constitutes a minority of the upper boundary, the lower boundary and the two side boundaries of the storing chamber 32. When the storing chamber 32 is in the low-pressure state, the box body 11, the front jointing unit 17 and the rear cover 16 endure a pressure caused by the pressure in the storing chamber 32 being less than the pressure of the exterior. It should be understood that, in an alternative embodiment, it is also possible that all of the upper, lower and two side walls of the storing chamber 32 are completely formed by the box body 11 made of metal.

The top wall 21, the bottom wall 23 as well as the left and right side walls 22 can be produced by a metal sheet, whose thickness is not more than 4 millimeters. Preferably, the thicknesses of these walls 21 to 23 are 2 millimeters to 2.5 millimeters.

The top wall 21, the bottom wall 23 as well as the left and right side walls 22 of the box body 11 are preferably formed in a one-piece structure, such that any jointing seam between these walls can be reduced or even eliminated. In the present embodiment, the top wall 21, the bottom wall 23 as well as the left and right side walls 22 are formed by a piece of metal sheet (cold rolled plate), which is bent into a rectangular shape and then is welded. As shown in figures 3 and 4, a welding seam 33 is located at the middle site of the right side wall 22. On the one hand, because the side wall 22 endures a less pressure than the top wall 21 and the bottom wall 23, this may facilitate reducing a possibility that air leakage occurs at the welding seam 33 under pressure. On the other hand, this may also facilitate arranging a clamp during the welding procedure. Furthermore, because the welding seam is located at a side wall which cannot be readily noticed by the user, this may facilitate achieving a better aesthetic of the refrigeration appliance 1.

15

It should be understood that, in an alternative embodiment, it is also possible that the top wall 21, the bottom wall 23 as well as the left and right side walls 22 of the box body 11 are formed by a plurality of metal sheets, which are jointed (such as welded) together.

20

Furthermore, the box body 11 can also be made of other metal such as aluminum. On the case that the box body is made of aluminum, the box body is preferably achieved by an integrally extruding procedure. Because the modulus of elasticity of aluminum is less than that of steel, it is preferable that the box body made of aluminum has a thickness of larger than 2 millimeters, for example being 4 millimeters.

25

In the present embodiment, the top wall 21 is symmetrical to the bottom wall 23. The two walls constitute a majority of the total wall area of the box body 11. When the low-pressure storage unit 7 is in a low-pressure state, the top wall 21 and the bottom

wall 23 endure more pressure than the other walls of the low-pressure storage unit 7. In order to increase moments of inertia of the top wall 21 and the bottom wall 23, the top wall 21 and the bottom wall 23 each are stamped with a plurality of protruding zones 34 which protrude outwardly.

5

According to a preferred embodiment of the present invention, as shown in figures 3, 4 and 5, mounting plates 27 are provided at the front and rear ends of the box body 11 and at outer sides of the top wall 21, the bottom wall 23 as well as the left and right side walls 22, such that no through hole needs be provided on the top wall 21, the bottom  
10 wall 23 as well as the left and right side walls 22 to secure the front jointing unit 17 and the rear cover 6 to the box body 11. The mounting plates 27 can be made of metal, for example made by steel sheets.

Each mounting plate 27 comprises a jointing foot 27a, which is horizontally secured on  
15 a corresponding one of the walls 21 to 23. In the present embodiment, the mounting plate 27 is secured on the box body 11 by welding the jointing foot 27a to the corresponding one of the walls 21 to 23. In an alternative embodiment, the mounting plate 27 can be secured on the box body 11 in other ways, for example is adhered on the box body 11.

20

The mounting plate 27 comprises an extension 27b, which folds from the jointing foot 27a and then extends outwardly. In the present embodiment, the extension 27b is substantially perpendicular to the corresponding one of the walls 21 to 23. The extension 27b has a plate shape. It has planar front and rear surfaces. The extensions  
25 27b at the front and rear ends of the box body 11 each are at a distance from the front and rear end faces of the box body 11.

In the present embodiment, the mounting plate 27 has an L-shape in its cross-section, which is formed by the extension 27b and the jointing foot 27a. However, in an

alternative embodiment, the extension 27b can be formed integrally on the corresponding one of the walls 21 to 23 such that the extension extends outwardly directly from the corresponding one of the walls 21 to 23 of the box body 11.

5 Each extension 27b is provided with a plurality of first holes 31a which extend through the front and rear surfaces of the extension. Preferably, the first holes 31a of each extension 27b are arranged at a predetermined interval with each other, and they are arrayed in a row. The first holes 31a located at the front and rear ends of the box body 11 each form a rectangular frame, whose size is larger than the front/rear opening 25,  
10 26. The corresponding rectangular frame encloses the box body 11 therein. The first holes 31a at the rear end of the box body 11 are threaded. However, the first holes 31a at the front end of the box body 11 are not threaded.

The rear cover 16 and the front jointing unit 17 according to a preferred embodiment of  
15 the present invention are particularly explained in their structures in detail below.

The rear cover 16 is connected to the rear opening 26 of the box body 11, constitutes the rear wall of the housing 40 and delimits the rear boundary of the storing chamber 32. The rear cover 16 is in the form of a square plate, which corresponds to the rear  
20 opening 26. The rear cover 16 has a size which is larger than that of the rear opening 26. The rear cover 16 extends beyond the rear opening 26.

The rear cover 16 is provided with an evacuation passage (not shown) extending all the way through the rear cover 16 and an evacuation valve unit 36 for selectively  
25 closing or opening the evacuation passage. In the present embodiment, the evacuation valve unit 36 extends above the top wall 21, and has a jointing opening 39 above the top wall 21. The low-pressure storage unit 7 connects with a pipeline secured on the cabinet 2 via the jointing opening 39, such that the low-pressure storage unit 7 can fluidly communicate with the evacuation device.

The rear cover 16 comprises a main wall portion 20 constituting the most part of the rear cover and a rear jointing portion 19, which is provided around the main wall portion 20 and connects the rear cover 16 to the edge of the rear opening 26. The rear jointing portion 19 connects with the entire edge of the rear opening 26.

In the present embodiment, the rear jointing portion 19 and the main wall portion 20 are produced by integral injection molding of plastic, whose modulus of elasticity is less than metal. Preferably, the rear cover 16 is made of material having a larger material strength, such as polycarbonate (PC). The main wall portion 20 made of PC has a thickness of about 6 millimeters. In order to enhance the strength of the main wall portion 20, the main wall portion 20 is provided with a plurality of reinforcing ribs 35 on its rear surface.

It should be understood that, in an alternative embodiment, the rear jointing portion 19 and the main wall portion 20 can be provided independently with each other, and then they are airtightly secured to form the rear cover 16. This will be particularly beneficial in the case that the rear jointing portion 19 and the main wall portion 20 are made of different materials.

The front jointing unit 17 connects at the entire edge of the front opening 25, and has a square framed structure forming a close-loop. The front jointing unit 17 has an abutting face 37 for abutting with the door 10. In the present embodiment, the abutting face 37 is planar, and is in the same longitudinal plane. When the door 10 is closed, the sealing element on the door 10 is pressed between the abutting face 37 and the door 10 to make a sealing effect.

In order that the front jointing unit 17 and the rear cover 16 are airtightly connected on the box body 11 respectively, the front jointing unit 17 and the rear cover 16 each are

provided with a ring-shaped groove 30 at a side facing the box body 11, which groove is used to receive a ring-shaped sealing element 18. The front and rear ends of the top wall 21, the side walls 22 and the bottom wall 23 of the box body 11 each are inserted into the corresponding groove 30. The sealing element 18 is located between the  
5 groove 30 and the box body 11.

Outside of the groove 30, the front jointing unit 17 and the rear cover 16 each are provided with a plurality of second holes 31b. These second holes 31b are provided on the outer surface portions of the front jointing unit 17 and the rear jointing unit 19  
10 beyond the top wall 21, the side walls 22 and the bottom wall 23, and are located outside of the storing chamber 32. The second holes 31b on the front jointing portion 17 and the rear cover 16 form rectangular frames respectively, each of which rectangular frames has a size which is larger than the front/rear opening 25, 26.

15 In the present embodiment, the second holes 31b on the front jointing unit 17 extend forwards from the rear side of the front jointing unit 17, do not extend through the front jointing unit 17 and thus form blind holes, which are threaded therein for attaching screws 29. The second holes 31b on the rear cover 16 extend forwards from the rear side of the rear jointing portion 19 through the rear jointing portion 19 and form through  
20 holes to be inserted by corresponding screws 29.

The front jointing unit 17 is formed by integral injection molding of plastic. In the present embodiment, because the front jointing unit 17 is provided with the threaded holes for attaching the screws 29, the front jointing unit 17 is formed from a mixture of  
25 PC resin having a larger strength and ABS resin having a better toughness by injection molding, such that the strength and the toughness of the unit is balanced.

The securing manner between the front jointing unit 17, the rear cover 16 and the box body 11 will be particularly explained below.

The front jointing unit 17 and the rear cover 16 are secured on the front and rear ends of the box body 11 by a plurality of securing units respectively.

5 In the present embodiment, each securing unit comprises the screw 29, the first hole 31a provided on the mounting plate 27 of the box body 11 and the second hole 31b provided on the front jointing unit 17/the rear cover 16. By inserting the screw 29 into the first hole 31a and the second hole 31b and then screwing the screw 29 with the threaded first hole 31a or the threaded second hole 31b, the front jointing unit 17/the rear cover 16 each can be reliably secured on the box body 11. By use of the screw 29, the securing unit provides a pretension force between the front jointing unit 17 and the box body 11 as well as between the rear cover 16 and the box body 11, such that the sealing elements 18 located between the front jointing unit 17/the rear cover 16 and the box body 11 can be pressed and thus the sealing effect between the front jointing unit 17/the rear cover 16 and the box body 11 can be enhanced.

In an alternative embodiment, the securing unit can adopt another securing piece which can provide the pretension force. For example, the screw can be replaced by a rod-shaped piece which is integrally injection molded on the front jointing unit 17 and the rear cover 16. In this case, the second holes 31b on the jointing frame 17 and the rear cover 16 can be omitted.

In the present embodiment, because all of the first holes 31a and the second holes 31b are located outside of the storing chamber 32, the interior of the storing chamber 32 cannot fluidly communicate with the exterior due to the arrangement of the first holes 31a and the second holes 31b. Furthermore, because the first holes 31a and the second holes 31b are located outside of the ring-shaped sealing element 18, the first holes 31a and the second holes 31b is in fact separated from the storing chamber 32 and does not communicate with it. In this way, a possibility that gas from the exterior

enters into the storing chamber 32 via the first holes 31a and the second holes 31b is eliminated. That is, these first and second holes 31a, 31b cannot have a negative effect on the air tightness of the storing chamber 32, such that the air tightness of the low-pressure storage unit 7 is improved.

5

In the embodiment of the present invention, the holes of the securing unit, which is used to secure the independently constructed box body, front jointing frame and rear cover, are arranged in such a manner that the evacuable storing chamber is not in fluid communication with fluid from the exterior. Thus this improves the air tightness of the housing which is obtained by several members being secured together to define the storing chamber. Although in the present embodiment the securing unit is used to secure different members made of different materials, it should be understood that this securing measure can be used to secure different members which are made of the same material but are constructed independently from each other.

15

Furthermore, in the embodiment of the present invention, the housing 40 of the low-pressure storage unit 7 comprises a first member (such as the box body 11) which is made of metal having a larger material strength, and a plurality of second members (such as the front jointing unit 17, the rear cover 16 and the door 10) which are made of plastic having a relatively smaller material strength and being easily molded. Therefore, on the one hand, the first member can obtain a larger strength by a smaller thickness to endure the exterior pressure, such that any deformation of the storing chamber 32 in the low-pressure state can be prevented; otherwise, it will influence the air tightness of the storing chamber 32. This advantage is particularly prominent in the case that the walls (such as the top wall 21 and the bottom wall 23) of the storing chamber 32 occupying the largest area are mainly or completely made of metal. Especially, when the housing 40 is mainly made of metal, this advantage is particularly prominent. On the other hand, because the housing comprises the second members (such as the front jointing unit 17, the rear cover 16 and the door 10), which are made of plastic and

20  
25

endure the pressure when the storing chamber 32 is in the low-pressure state, provided on these second members can be relatively complex, high accuracy requiring and perfect air tightness requiring structures (such as a perfect air tightness requiring gas filling valve, an evacuation valve unit and so on) so as to improve the air tightness of the low-pressure storage unit. Further, because the first member made of metal can have a smaller thickness and a good thermal conductivity, heat can be well conducted between the exterior and the interior of the storing chamber even if the second member has a larger thickness. Furthermore, when the second members constitute only a small portion of the housing and especially they are not provided in a box-shaped structure, the molding process of them is relatively easy. Meanwhile, because they are only the small portion of the low-pressure storage unit 7, they do not have a significant effect on the heat conducting between the exterior and the interior of the low-pressure storage unit 7. It can be seen that, by constructing the housing by different members made of different materials, an improved air tightness can be obtained by the producer and it is prospective that the low-pressure storage unit is easily manufactured.

## CLAIMS

1. A low-pressure storage unit (7) for a refrigeration appliance (1), wherein the  
5 low-pressure storage unit (7) defines an evacuable storing chamber (32), and the  
low-pressure storage unit (7) comprises:  
a first member (11), which first member (11) forms a part of a wall of the storing  
chamber (32);  
a second member (16, 17), which second member (16, 17) is constructed  
10 independently from the first member (11) and forms a part of the wall of the storing  
chamber (32), and  
a sealing element (18) for connecting the first member (11) with the second member  
(16, 17) in an airtight manner;  
characterized in that the low-pressure storage unit further comprises  
15 at least one securing unit for securing the first member (11) and the second member  
(16, 17), wherein the securing unit comprises a hole (31a, 31b) that is at least provided  
in at least one of the first member (11) and the second member (16, 17), and a  
securing member (29) inserted into the hole (31a, 31b), wherein the securing unit is  
constructed in such a way that the interior of the storing chamber (32) is not in fluid  
20 communication with the exterior thereof.
2. The low-pressure storage unit (7) according to claim 1, characterized in that the hole  
(31a, 31b) is entirely located inside or outside the storing chamber (32).
- 25 3. The low-pressure storage unit (7) according to claim 1, characterized in that the hole  
(31a, 31b) is isolated from the storing chamber (32).
4. The low-pressure storage unit (7) according to claim 1, 2 or 3, characterized in that  
the first member (11) and the second member (16, 17) each comprise a first

connecting portion (27b) and a second connecting portion, both of which portions are located outside the storing chamber (32), and that the securing unit is provided on the first connecting portion (27b) and the second connecting portion.

5 5. The low-pressure storage unit (7) according to claim 4, characterized in that at least one of the first connecting portion (27b) and the second connecting portion is formed integrally on a corresponding one of the members (11, 16, 17).

10 6. The low-pressure storage unit (7) according to claim 4, characterized in that the first member (11) comprises at least one mounting plate (27) secured to the first member (11) and forming the first connecting portion (27b), and that the mounting plate (27) comprises a foot (27a) connected to an outer surface of the first member (11) and an extension folding from the foot (27a) and then extending outwardly to form the first connecting portion (27b).

15

7. The low-pressure storage unit (7) according to claim 6, characterized in that the mounting plate (27) has an L-shaped cross section.

20 8. The low-pressure storage unit (7) according to any one of the preceding claims, characterized in that the securing unit is constructed to provide a pretension force for the first member (11) and the second member (16, 17).

9. The low-pressure storage unit (7) according to any one of the preceding claims, characterized in that the securing member (29) is a screw (29).

25

10. The low-pressure storage unit (7) according to any one of claims 1 to 8, characterized in that the securing member comprises a rod-shaped part formed integrally on the first member and/or the second member.

11. The low-pressure storage unit (7) according to any one of the preceding claims, characterized in that the first member (11) and the second member (16, 17) are made of different materials whose elastic ratios are different from each other respectively.

5 12. The low-pressure storage unit (7) according to any one of the preceding claims, characterized in that the first member (11) is made of metal, such as steel or aluminum.

13. The low-pressure storage unit (7) according to claim 12, characterized in that the second member (16 and 17) is made of plastic.

10

14. The low-pressure storage unit (7) according to claim 12 or 13, characterized in that the first member (11) forms at least a majority of a plurality of interconnected walls of the storing chamber (32).

15 15. The low-pressure storage unit (7) according to any one of the preceding claims, characterized in that the first member (11) is of a box-structure and has at least one opening (25, 26), and that the second member (16, 17) is secured to the first member (11) along the opening (25, 26).

20 16. The low-pressure storage unit (7) according to claim 15, characterized in that it comprises a plurality of securing units that are spaced apart from one another, and that these securing units are provided around the opening (25, 26) and form at least one frame surrounding the opening (25, 26).

25 17. The low-pressure storage unit (7) according to claim 15 or 16, characterized in that it comprises a door (10), wherein said at least one opening (25, 26) comprises a front opening (25) that can be selectively opened and closed by the door (10), and that the second member (17) has a close-loop-frame shape and is connected to the entire edge of the front opening (25) such that a connection frame is formed to abut with the

door (10).

18. The low-pressure storage unit (7) according to claim 17, characterized in that the hole (31b) provided in the second member (17) is a blind hole, one end of which is  
5 opened to a rear surface of the second member (17).
19. The low-pressure storage unit (7) according to claim 17 or 18, characterized in that the second member (17) has a planar abutting surface for abutting with the door (10).
- 10 20. The low-pressure storage unit (7) according to any one of claims 1 to 16, characterized in that the second member (16) is of a generally plate-shaped structure, and forms an entire wall of the storing chamber (32), and the hole (31b) is located on the peripheral region of the second member (16).
- 15 21. The low-pressure storage unit (7) according to any one of the preceding claims, characterized in that the second member (16, 17) has a ring-shaped groove (30) for receiving at least a part of the sealing element (18), and that the securing unit is located on the outer periphery of the ring-shaped groove (30).
- 20 22. A refrigeration appliance (1), comprising a low-pressure storage unit (7) according to any one of the preceding claims.

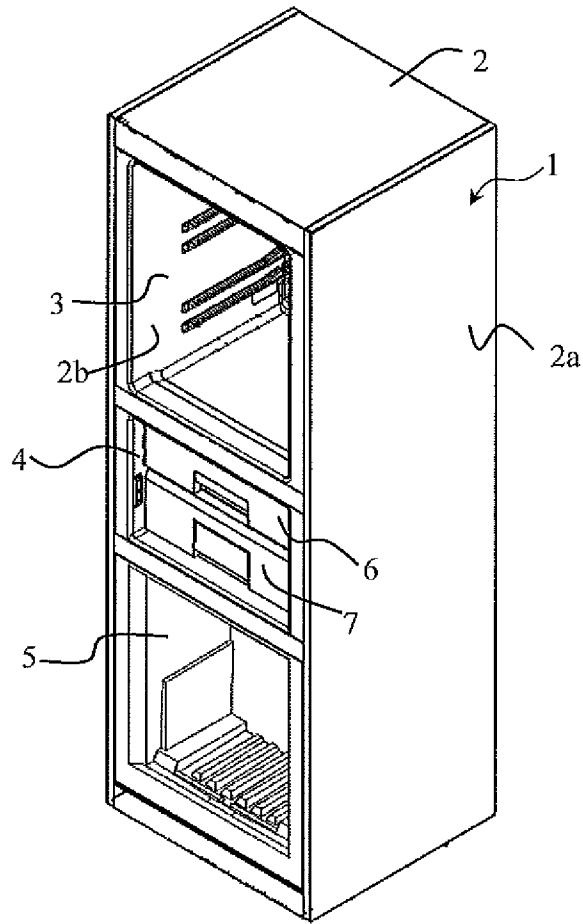

Figure 1

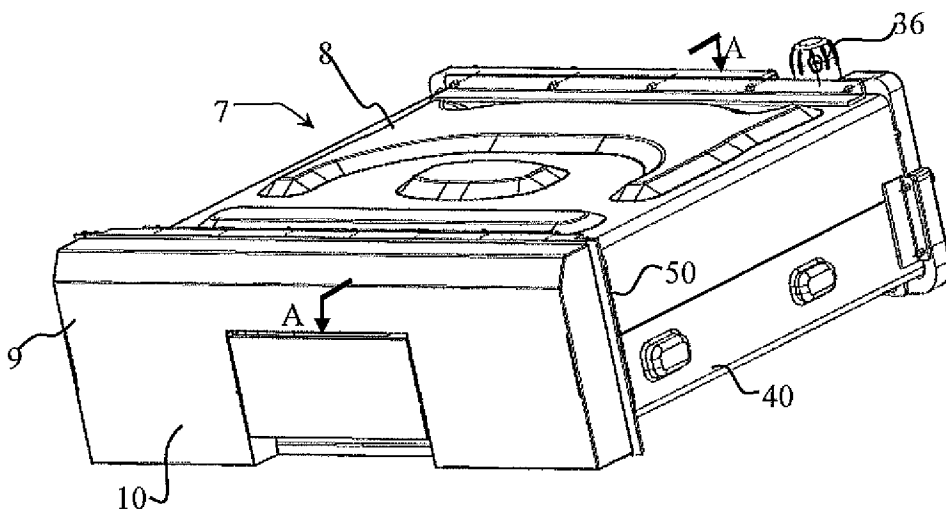

Figure 2



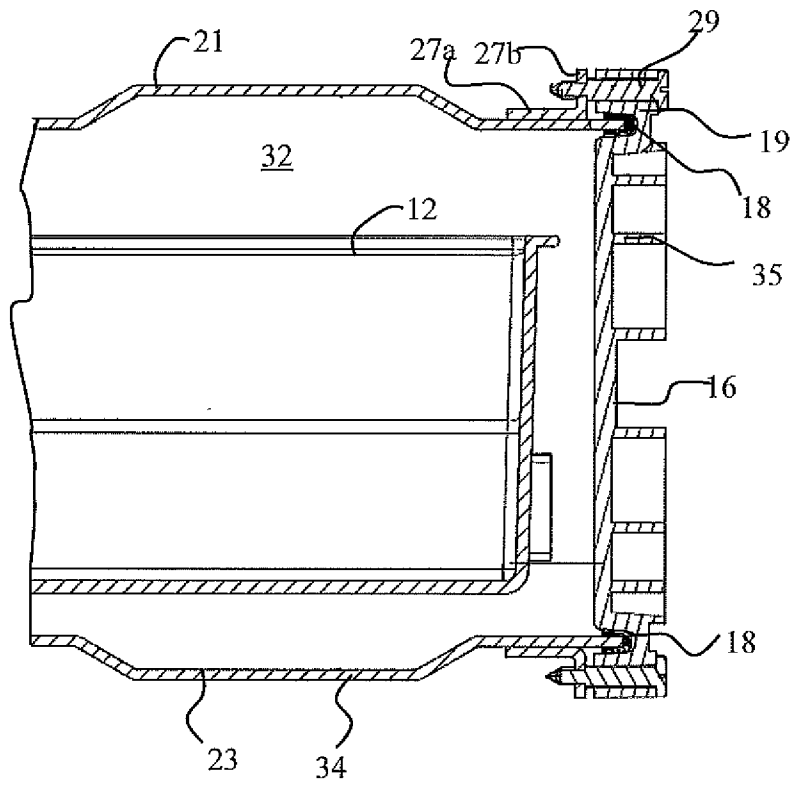

Figure 5