



US 20150300639A1

(19) **United States**
(12) **Patent Application Publication**
STADLER et al.

(10) **Pub. No.: US 2015/0300639 A1**
(43) **Pub. Date: Oct. 22, 2015**

(54) **ROTARY PLOUGHS FOR GASIFIERS**

(52) **U.S. Cl.**

(71) Applicant: **SASOL TECHNOLOGY (PROPRIETARY) LIMITED, Johannesburg (ZA)**

CPC . **F23H 15/00** (2013.01); **C10J 3/42** (2013.01); **C10J 2200/09** (2013.01)

(72) Inventors: **Jacobus Andreas STADLER, Parys (ZA); Andrei Frederik KOEKEMOER, Parys (ZA); Marnus Tertius BEUKMAN, Sasolburg (ZA); Nkosinathi HADEBE, (US); Daniel FRANCIS, Sandton (ZA); Gavin Shawn DEAS, Sasolburg (ZA); Johannes Marthinus DU TOIT, Secunda (ZA)**

(57) **ABSTRACT**

A solids handling equipment rotary plough includes a metal body defining a pair of opposed spaced non-parallel elongate faces extending between a bottom and a top and from a first end to a second end of each opposed elongate face, the first end and the second end being spaced further from each other than the top and the bottom are spaced from each other providing each opposed elongate face with a length greater than a height. The opposed elongate faces are on opposite sides and facing away from a first imaginary vertical plane, each of said opposed elongate faces having at least two elongate major surfaces which are not co-planar, an upper, elongate, non-vertical, major surface being angled towards the first imaginary vertical plane to slope upwardly and a lower, elongate, vertical, major surface being angled in a horizontal plane so that the first ends of the opposed elongate faces are closer to each other than the second ends. The elongate faces are joined by a connector defining mounting means to mount the rotary plough to a rotatable grate component.

(21) Appl. No.: **14/481,646**

(22) Filed: **Sep. 9, 2014**

(30) **Foreign Application Priority Data**

Apr. 16, 2014 (ZA) 2014/02831

Publication Classification

(51) **Int. Cl.**
F23H 15/00 (2006.01)
C10J 3/42 (2006.01)

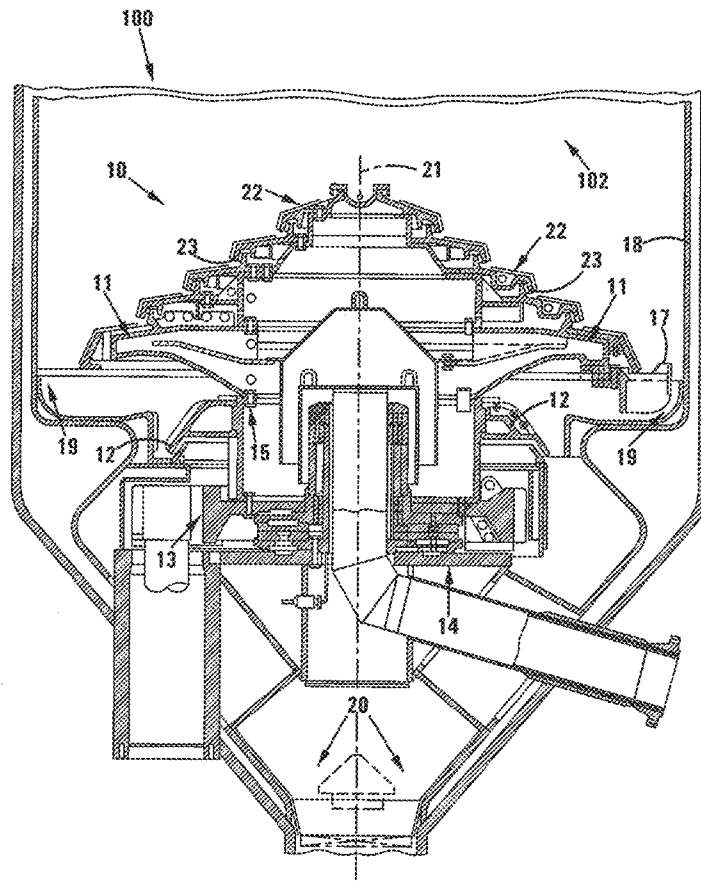

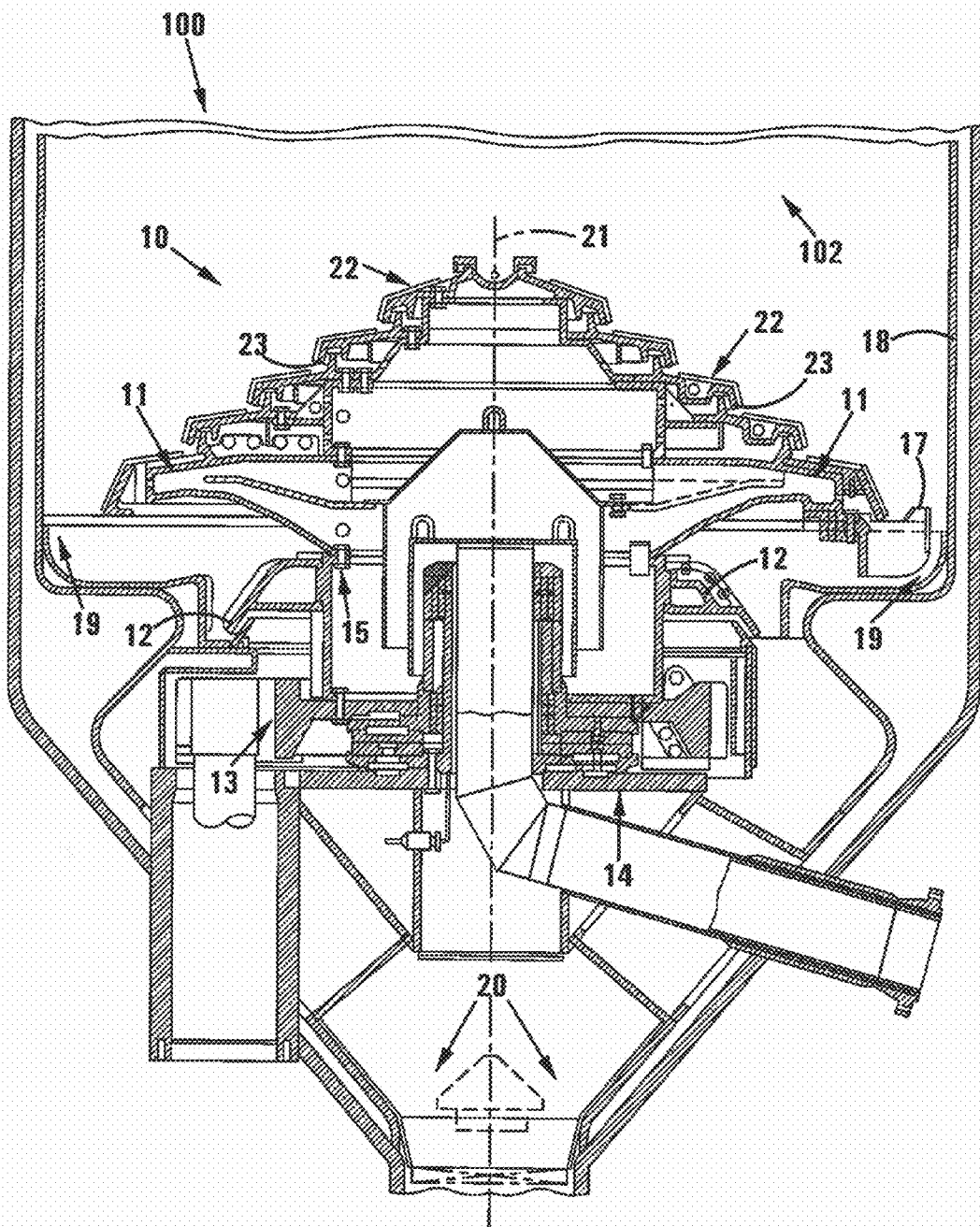

FIG 1

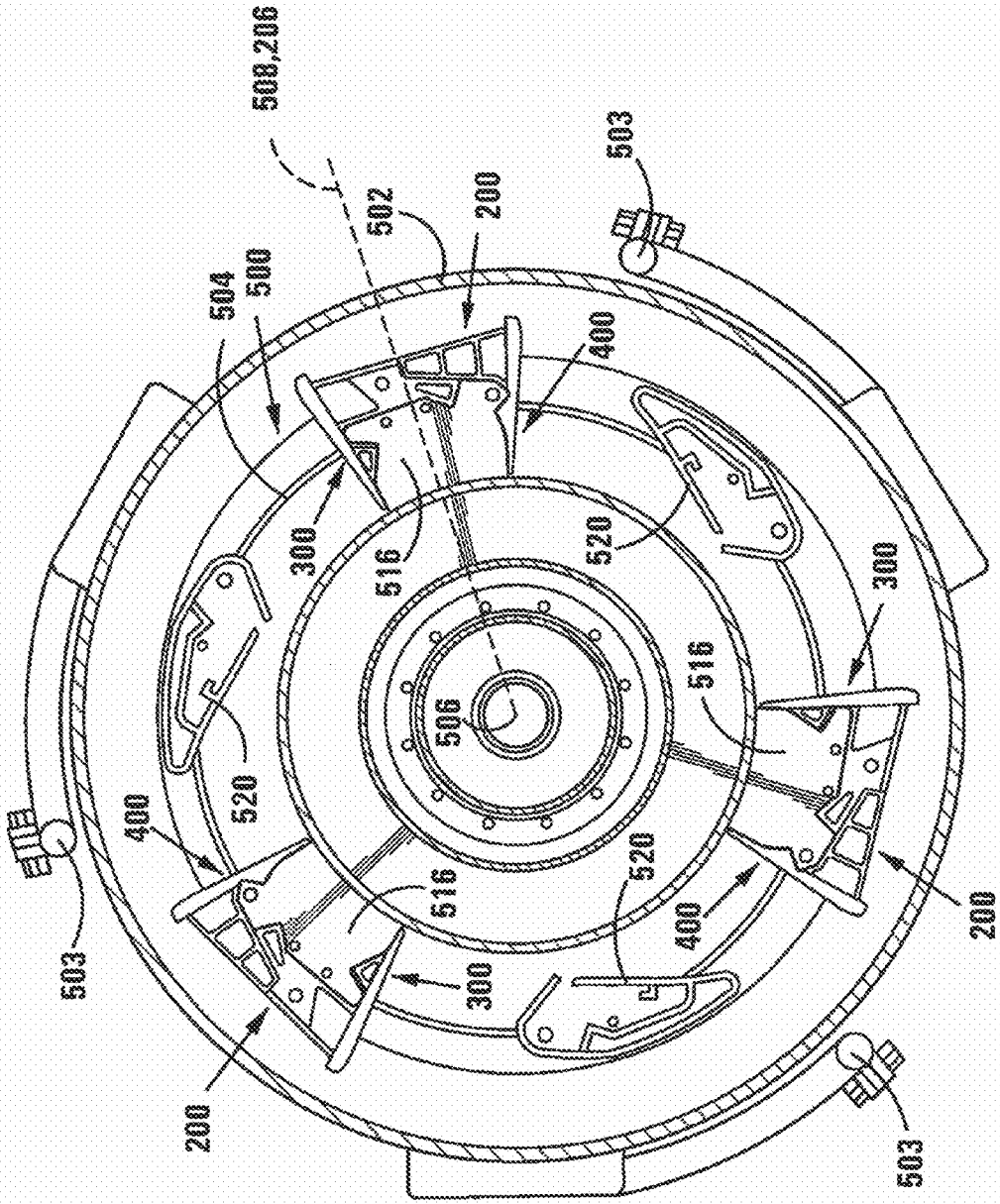
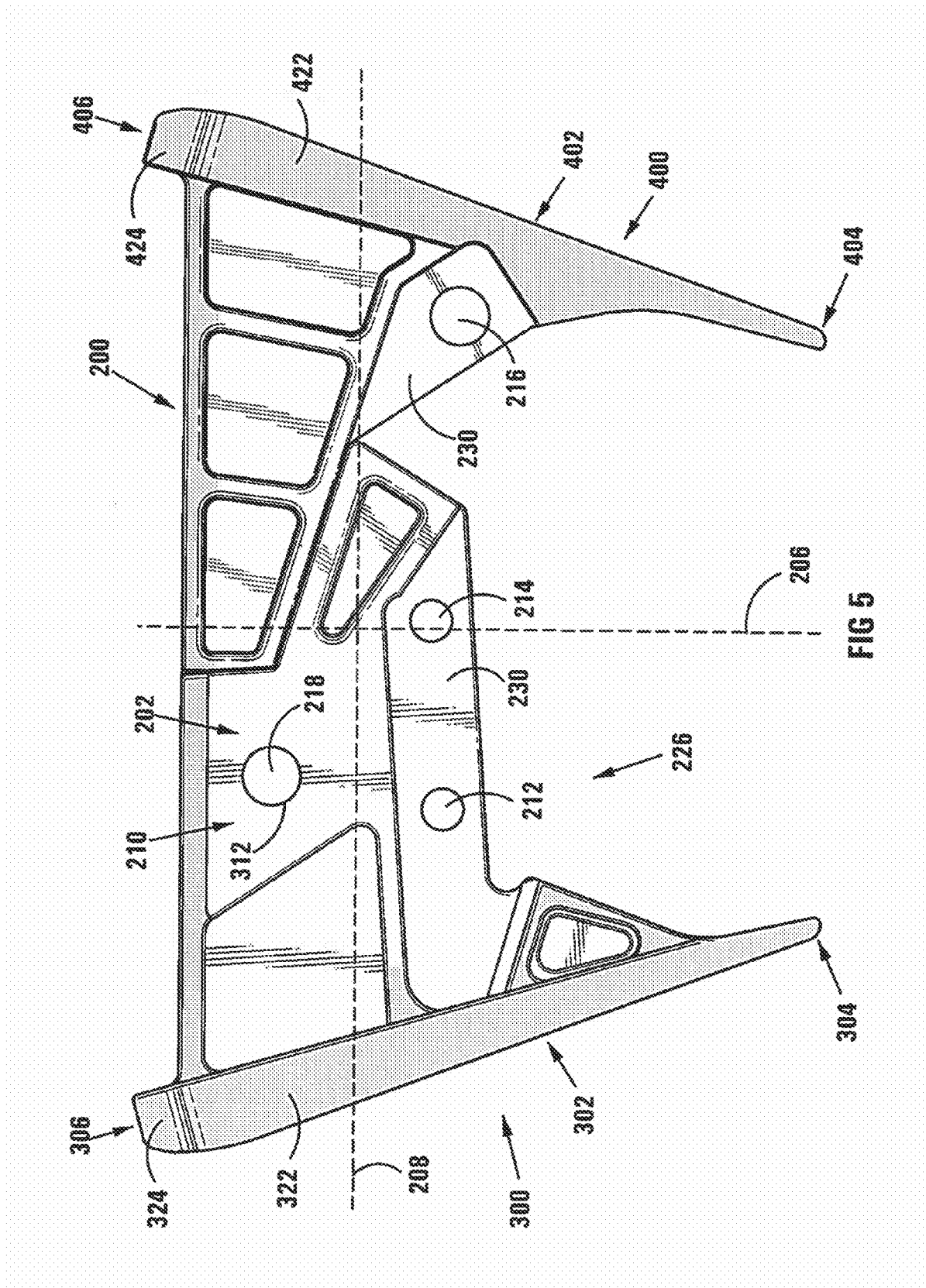

FIG 2



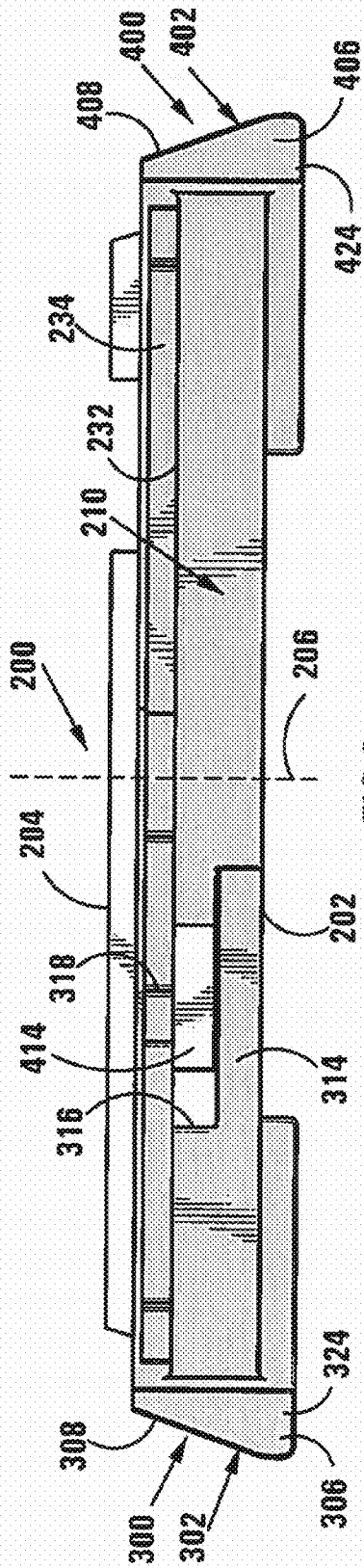

FIG 6

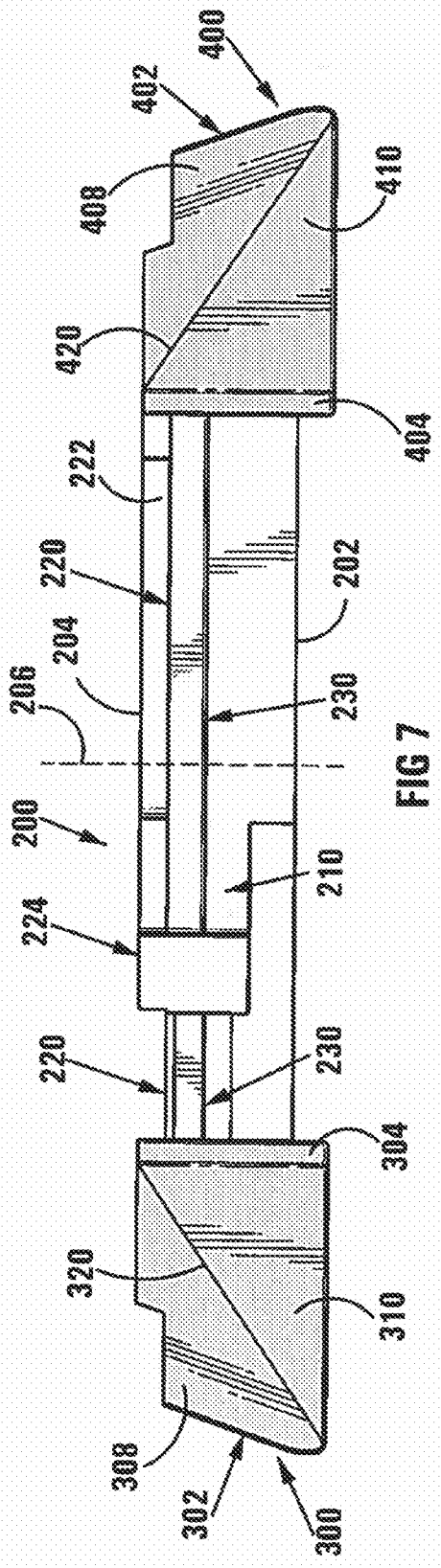

FIG 7

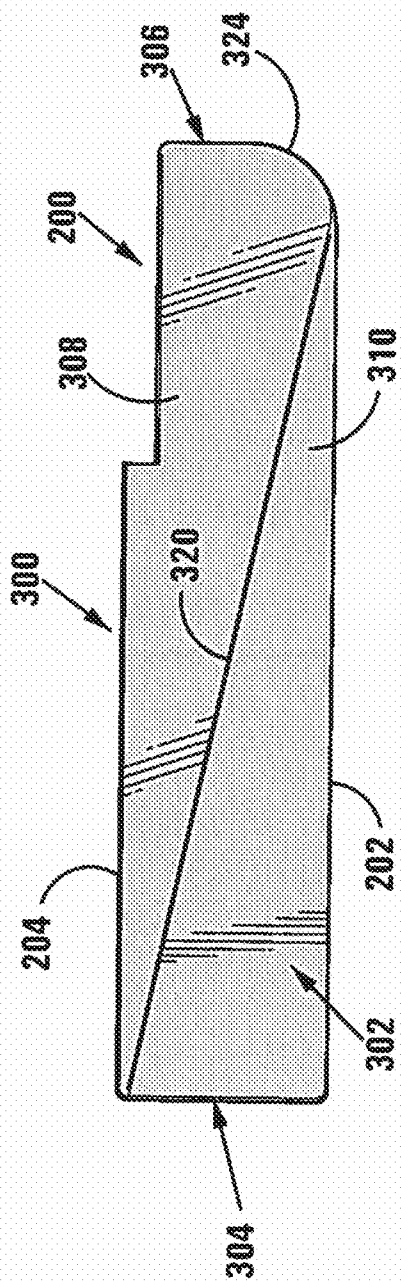

FIG 8

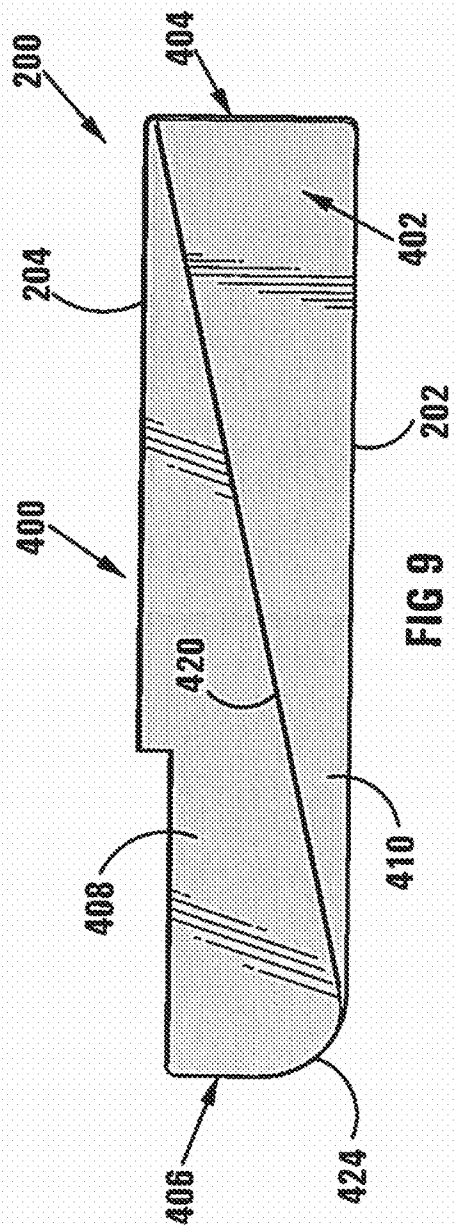
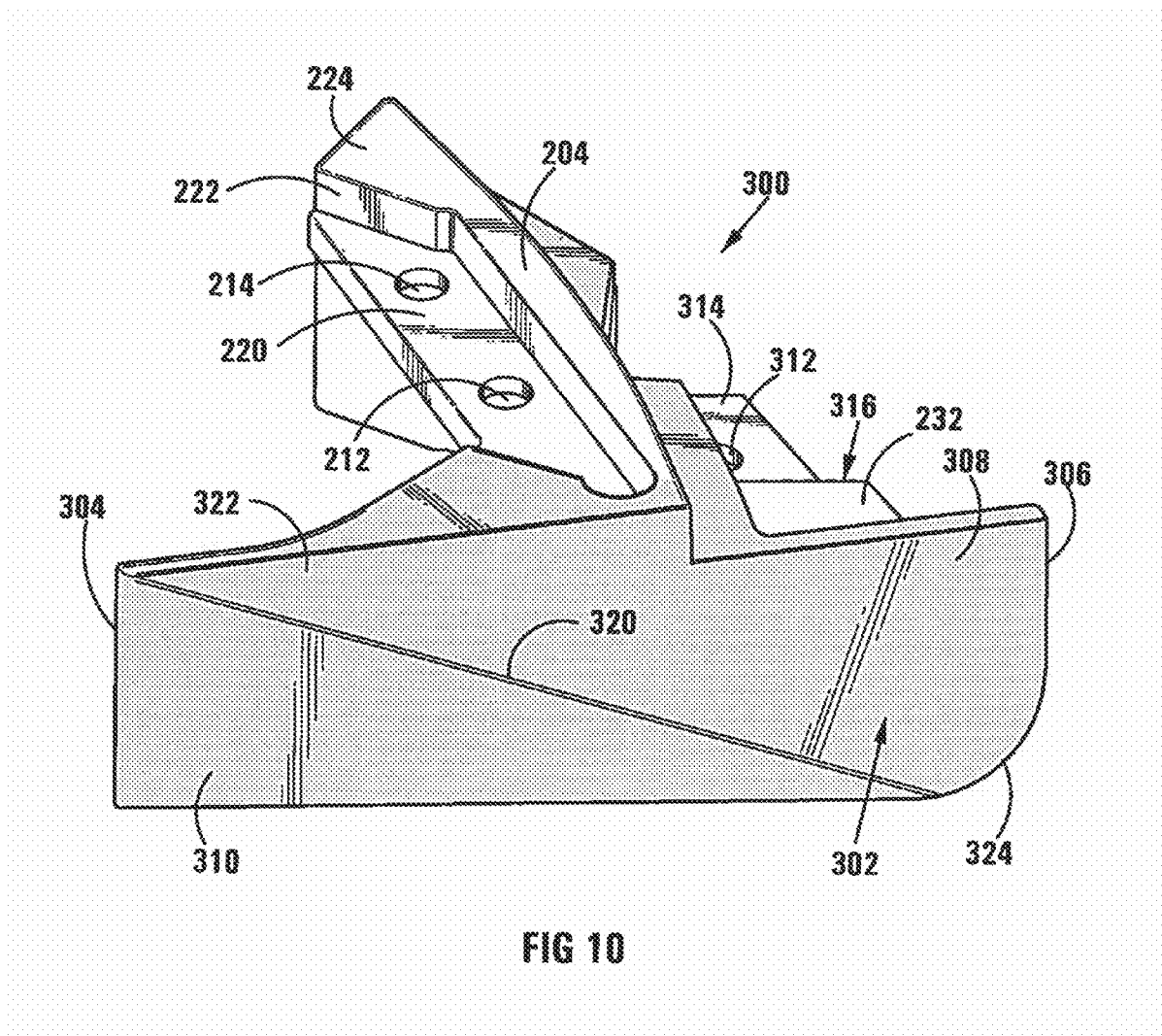

FIG 9



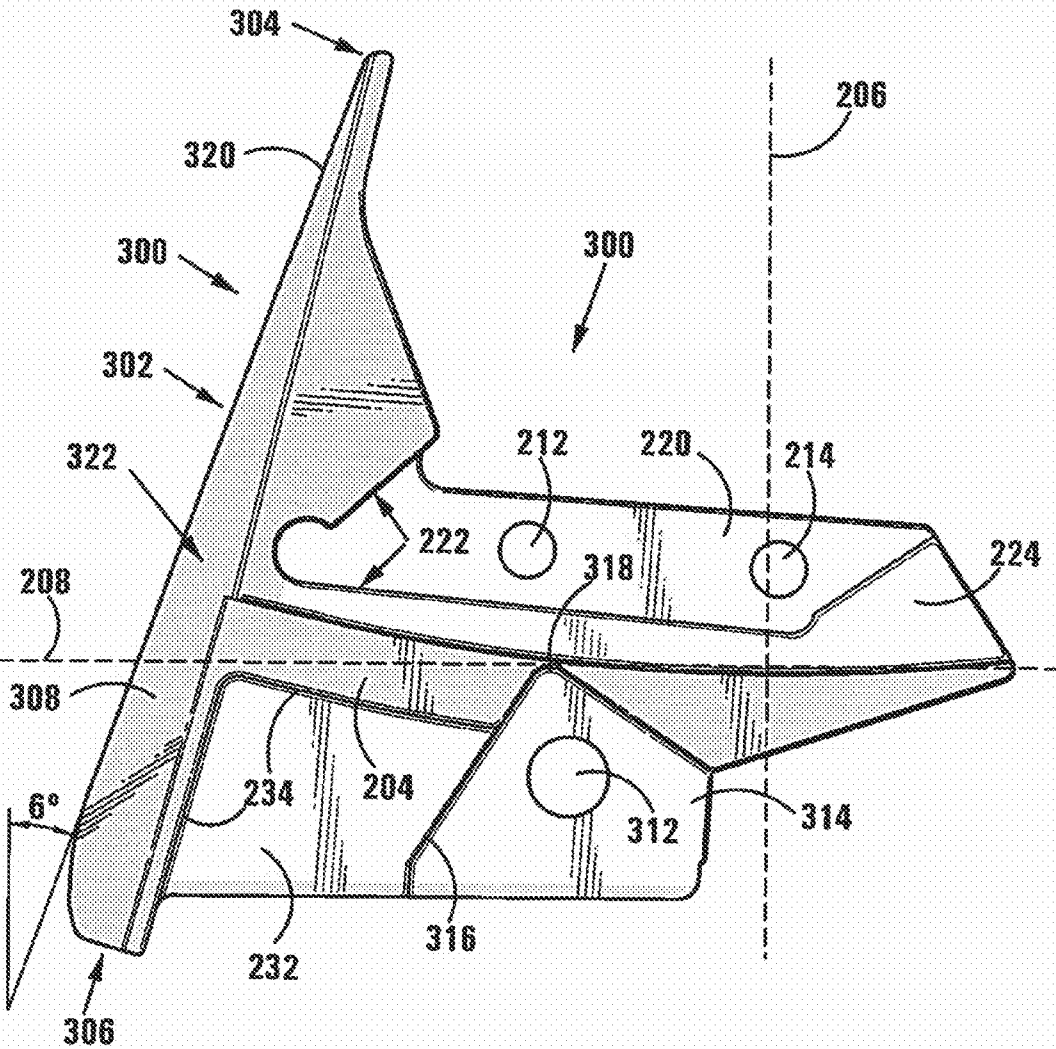
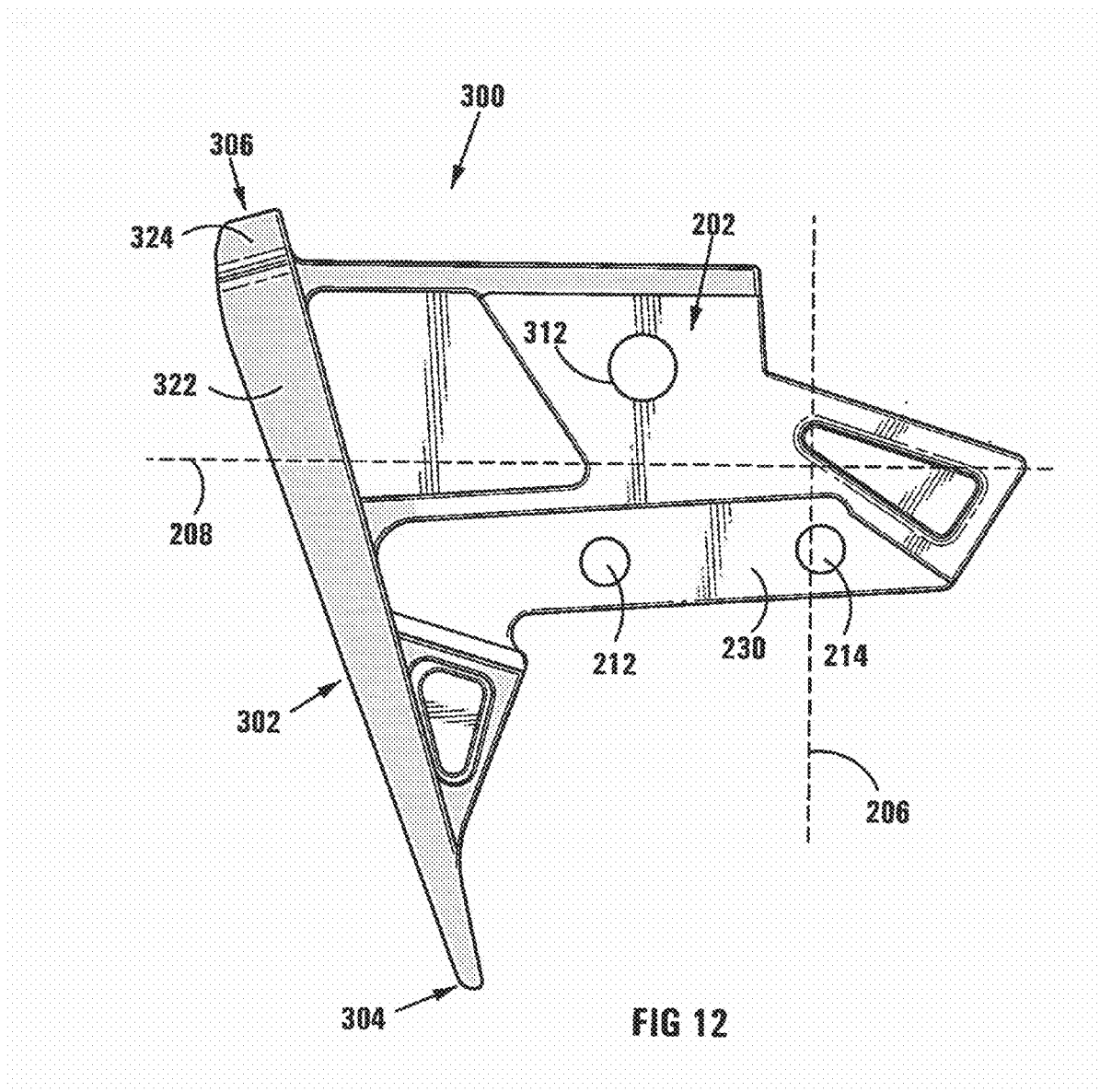

FIG 11



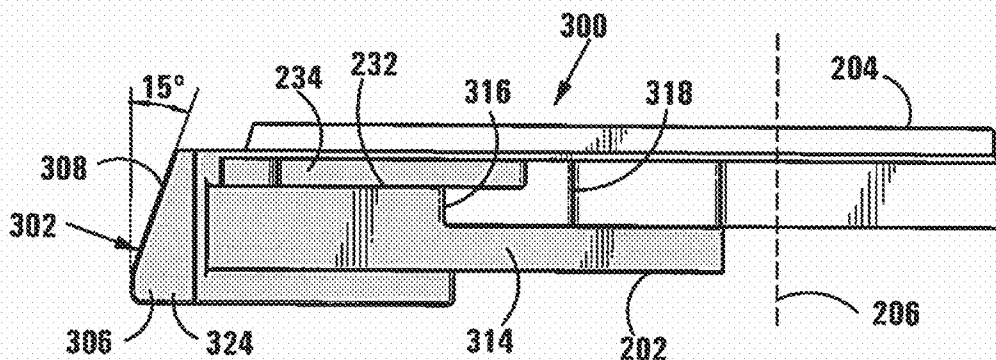

FIG 13

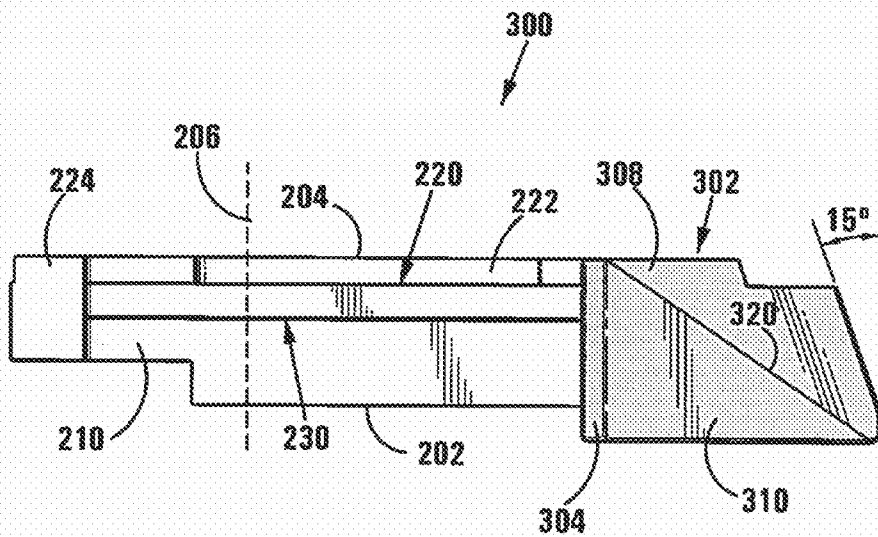
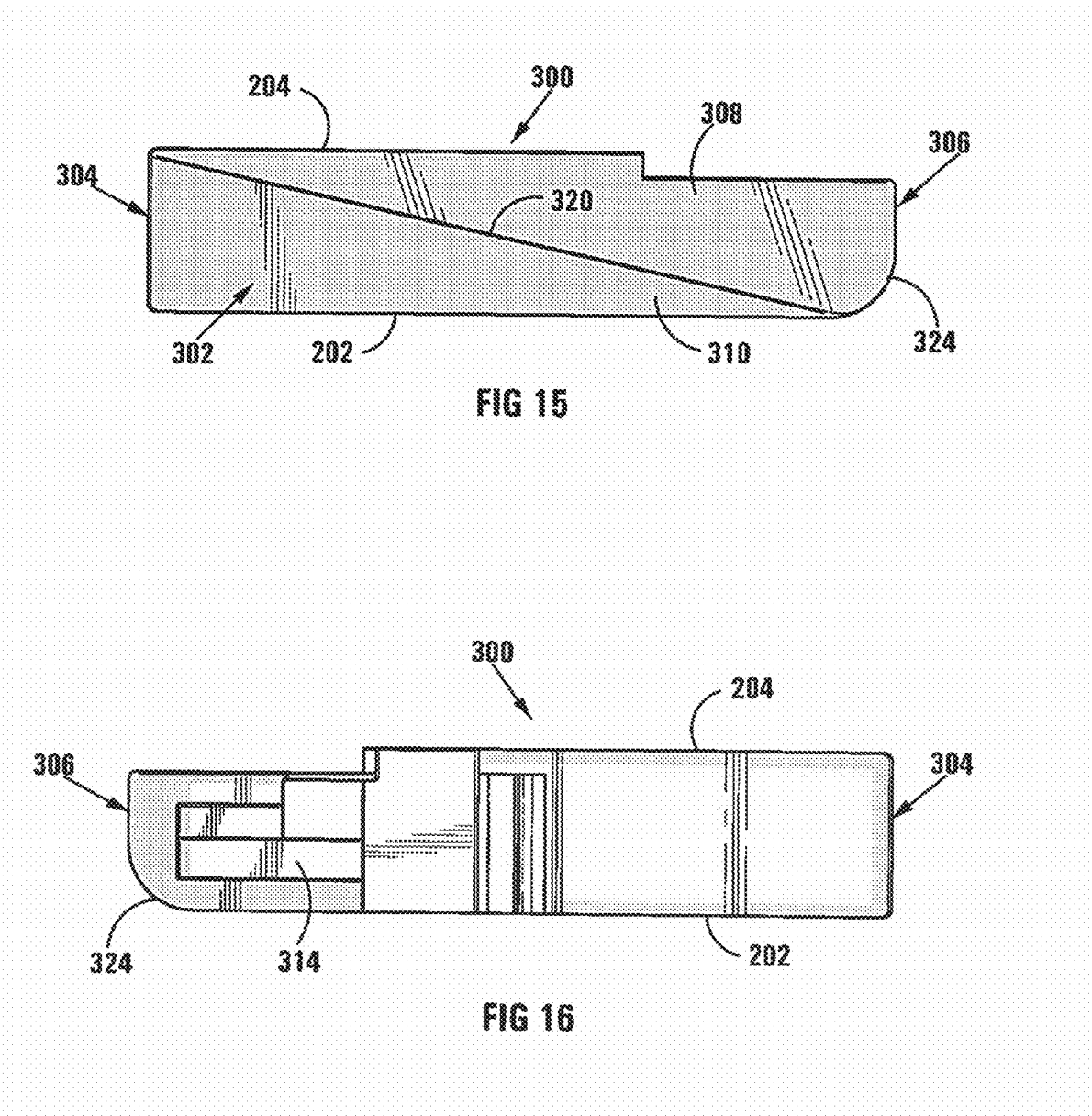
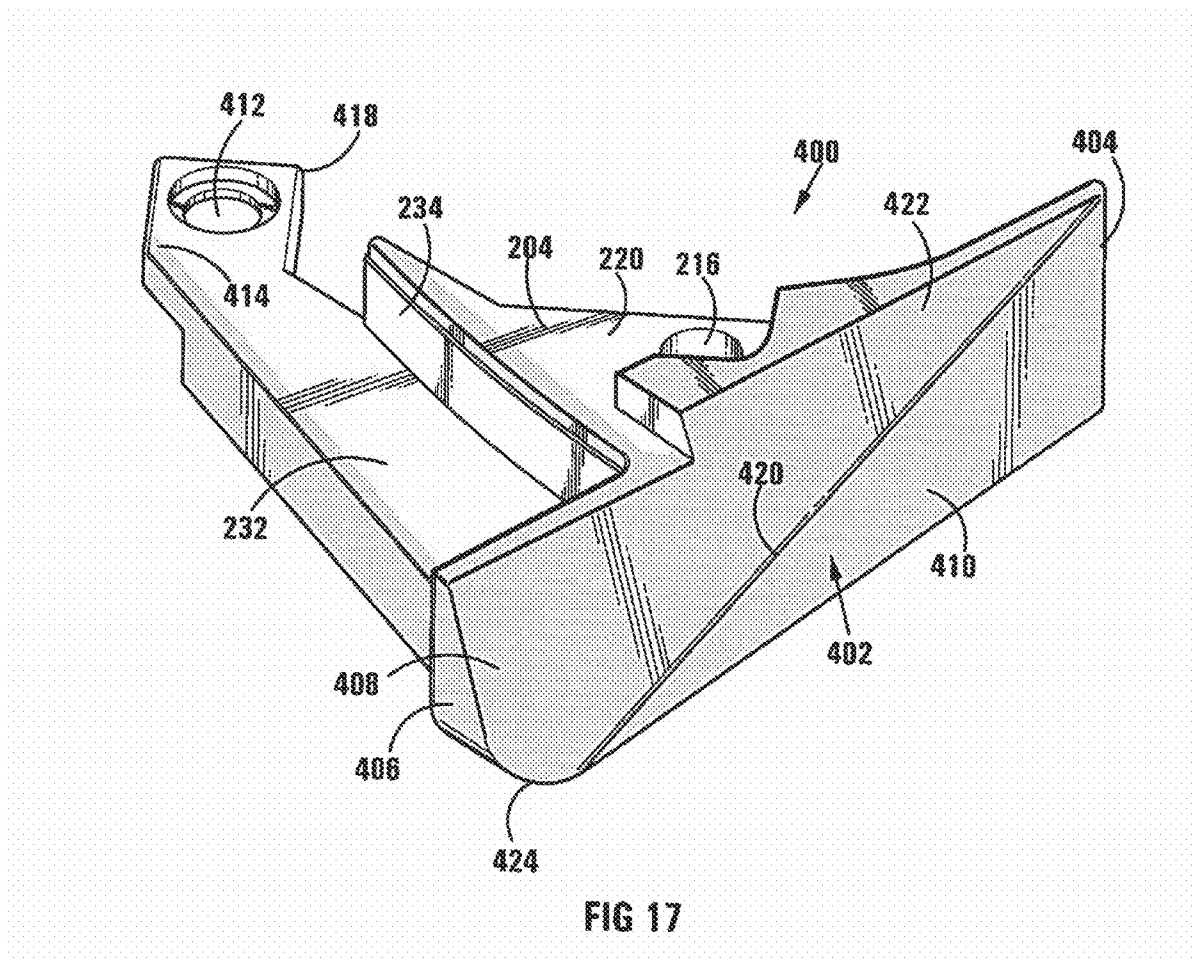

FIG 14





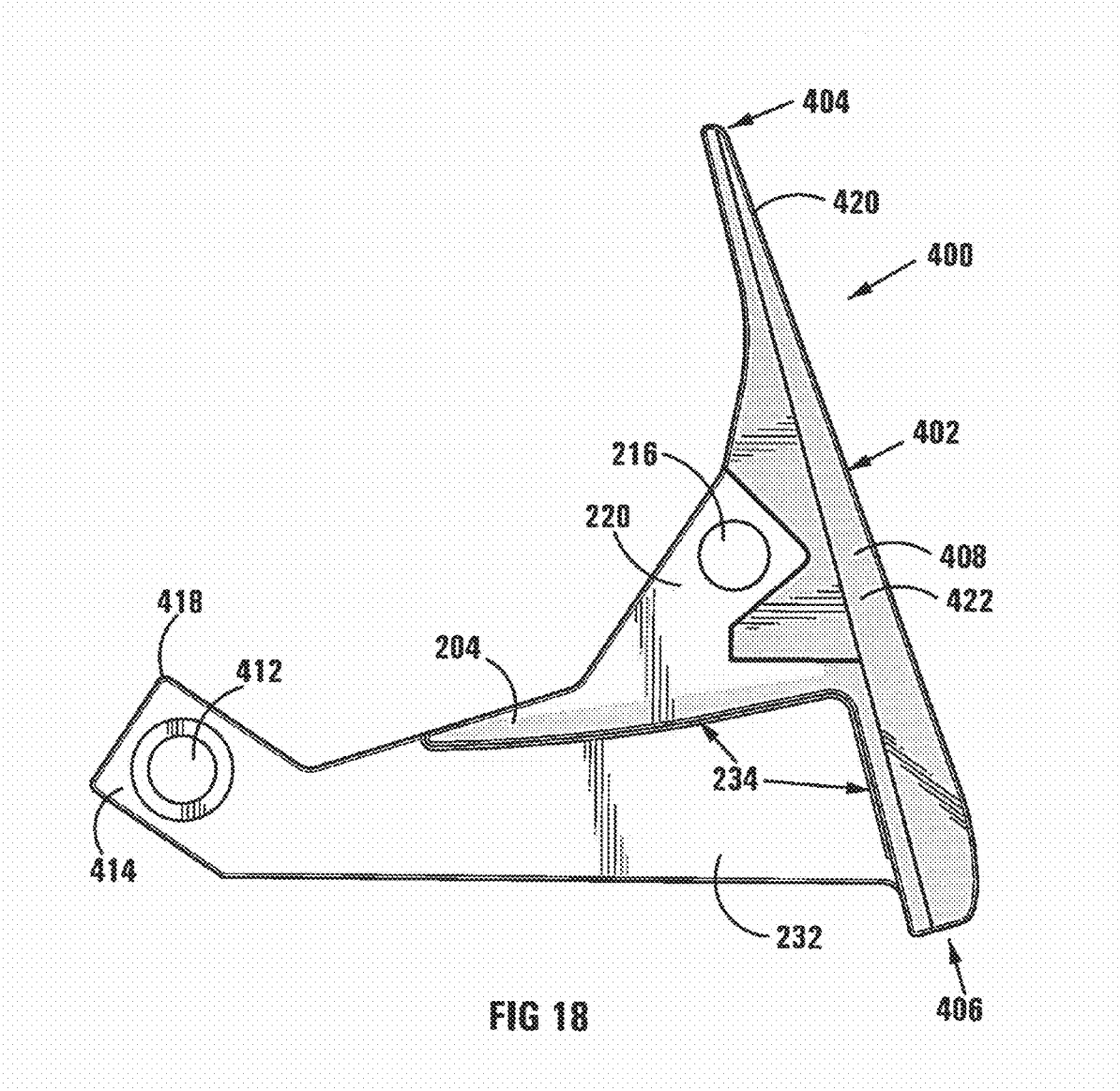
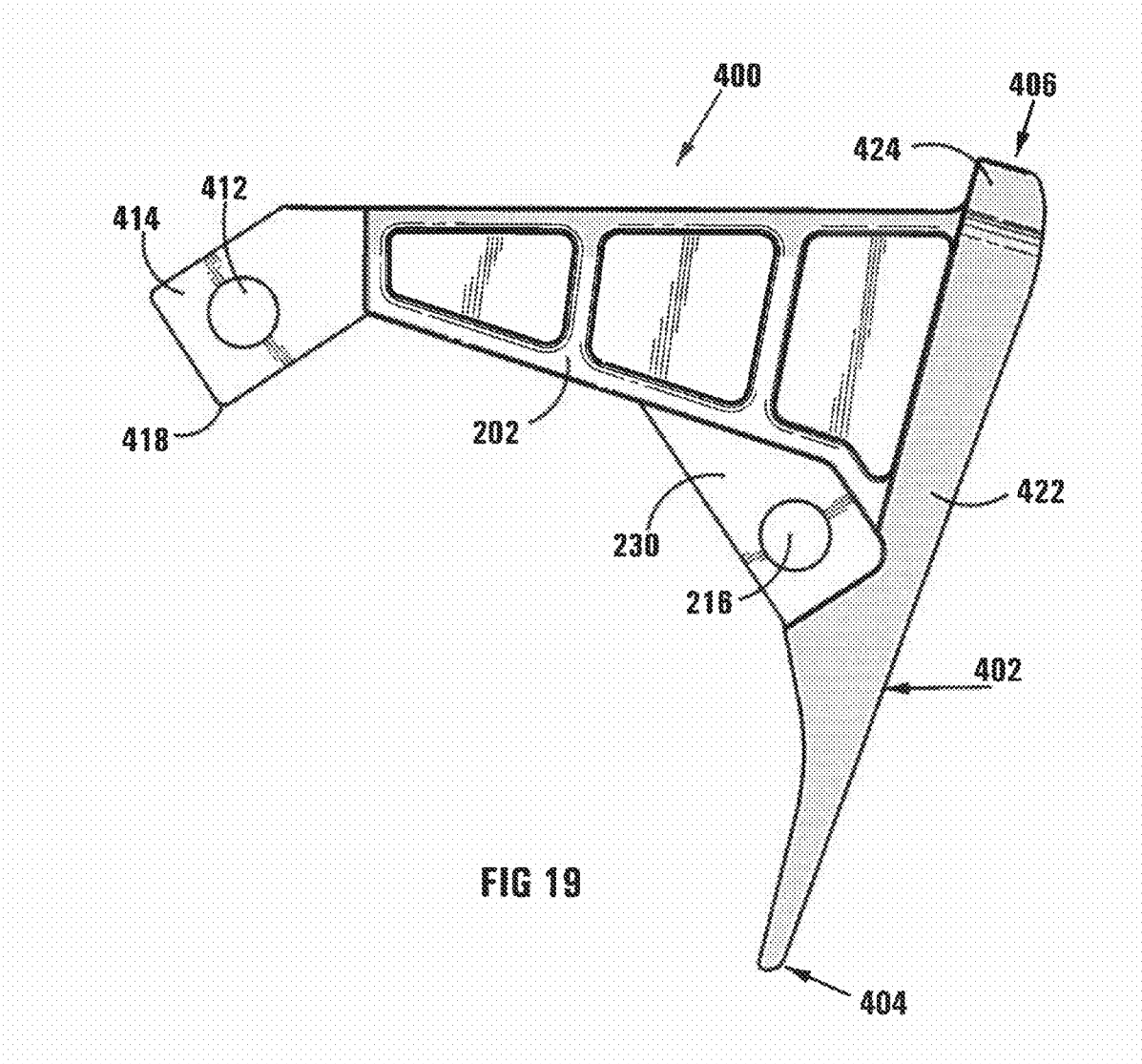
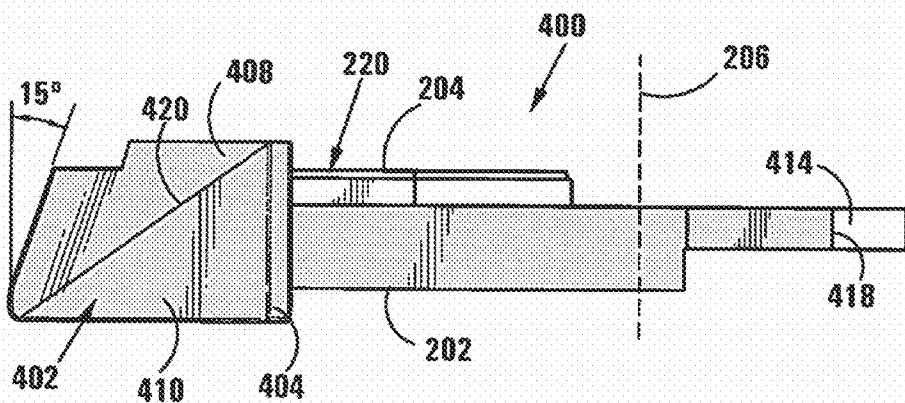
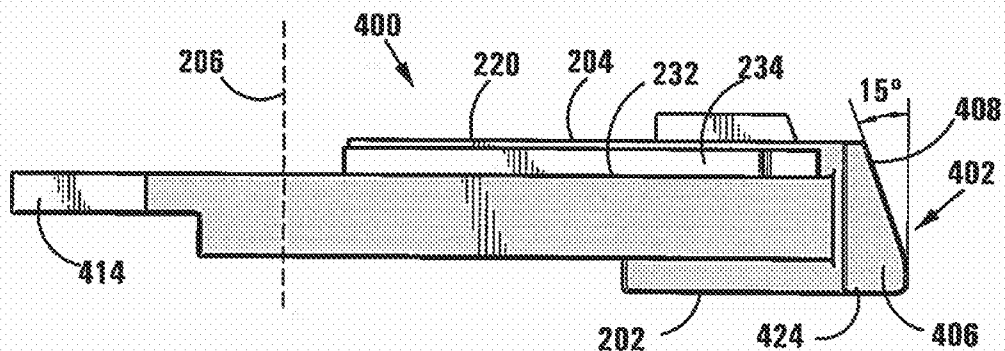

FIG 18





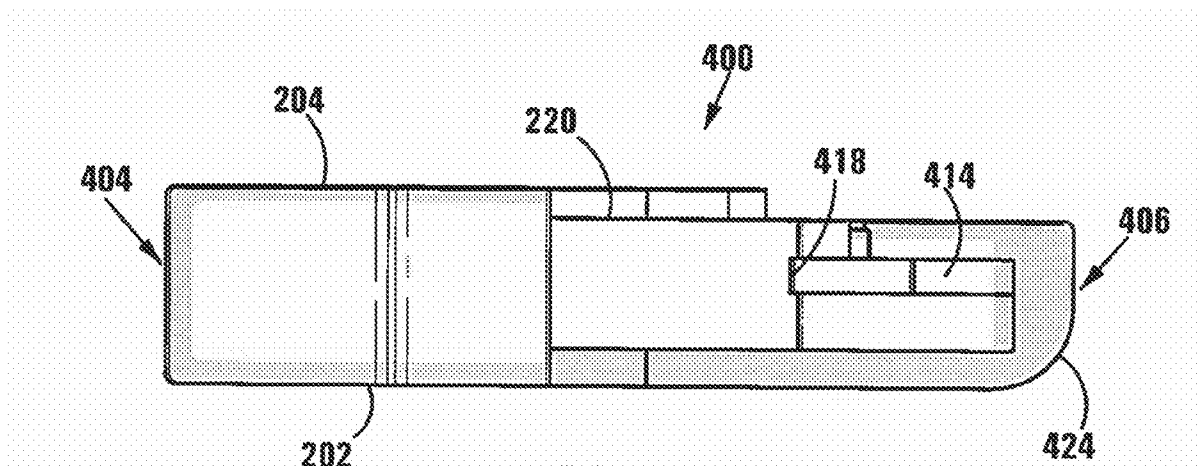

FIG 22

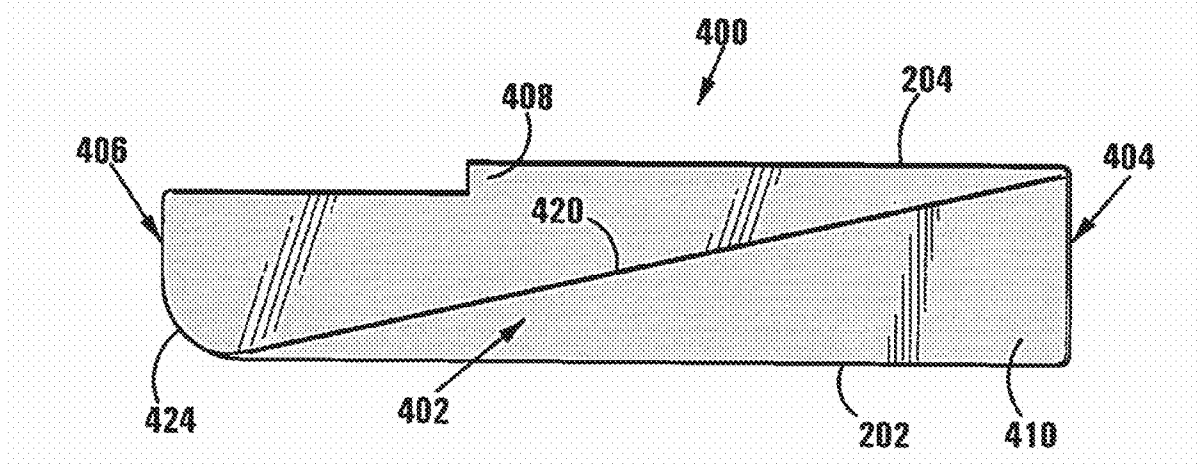

FIG 23

ROTARY PLOUGHS FOR GASIFIERS

CROSS-REFERENCE TO RELATED APPLICATIONS

[0001] This application claims the benefit of South African Provisional Patent Application No. 2014/02831 filed on Apr. 16, 2014, the entire disclosure of which is incorporated herein by reference.

FIELD

[0002] THIS INVENTION relates to rotary ploughs for gasifiers. In particular, the invention relates to a solids handling equipment rotary plough, to a solids handling equipment rotary plough part or component, to a rotatable grate assembly for a gasifier for gasifying carbonaceous material producing ash and to a gasifier for gasifying carbonaceous material.

SUMMARY

[0003] For some gasifiers, such as the Sasol® FBDB™ gasifier, it is necessary intermittently or continuously to load and unload particulate material, such as particulate carbonaceous material (e.g. coal) and ash. Thus, for example, in the case of a pressurized gasifier (e.g. a fixed bed dry bottom gasifier), particulate carbonaceous feedstock, e.g. coal, is loaded into a pressurised gasification chamber of the gasifier to form a bed (in the case of a fixed bed gasifier), and gasified at elevated temperatures and pressures, and after gasification any remaining ungasified material is removed from the gasifier as ash via a rotatable grate assembly and an ash lock.

[0004] The rotatable grate assembly has two main mechanical functions. Primarily it is used to extract ash from the bottom of the gasification chamber, but it is also used to crush and remove any ash agglomerates (clinkers) that may be formed in the gasification process. The rotatable grate assembly is typically also used to distribute gasification agent (typically a mixture of steam and oxygen) into the bed of carbonaceous material.

[0005] Typically, a conventional rotatable grate assembly comprises of a number of components, principally an upper roughly conical-shaped rotatable grate component, a lower rotatable support structure rigidly connected to the upper rotatable grate component at an upper periphery of the rotatable support structure so that the rotatable grate component and the rotatable support structure rotate together about a common axis of rotation, and a ring gear connected at a lower periphery of the rotatable support structure. A lowermost stationary support structure is provided on which the rotatable components are supported. In use, the rotatable grate assembly is rotated when the ring gear which is drivingly connected to the lower rotatable support structure is driven via a motor and gearbox assembly which turns the rotatable components of the rotatable grate assembly.

[0006] As the rotatable grate assembly is rotated, one or more symmetrically circumferentially spaced ploughs which are rigidly connected to an outer periphery of the upper rotatable grate component act to remove the ash from the bottom of the gasifier. Ash consists of dry coarse ash and clinkers, which are by-products of the gasification process. Clinkers are solid agglomerates of particles of melted ash. Clinkers need to be crushed in order efficiently to be removed from the gasifier. The ploughs continuously scrape the ash through an ash discharge passageway which is defined between the upper

rotatable grate component of the rotatable grate assembly and a wall of the gasifier. As the rotatable grate assembly rotates, the clinkers are crushed between shield plates mounted on the upper rotatable grate component and wear bricks mounted on the wall of the gasifier. The ash and clinkers fall under force of gravity from the ash discharge passageway into an ash lock which is in communication with the ash discharge passageway, to exit the gasifier.

[0007] The operation of and the removal of ash from a fixed bed gasifier are well known in the art and described in detail in WO 2006/061738.

[0008] The Applicant has experience with two existing plough designs. The first is a conventional “short straight plough” and the second is the Sasol® Banana Plough™ which is currently in commercial use in South Africa in the Sasol® FBDB™ gasifier. The Sasol® Banana Plough™ has been in commercial use for more than 40 years and is thus well known to persons skilled in the art of gasifiers. The major differences between the short straight plough and the Sasol® Banana Plough™, which has curved leading and trailing faces, with the leading and trailing faces curving in the same direction, resembling to some extent a banana, is that the short straight plough has planar leading and trailing faces. Reference hereinafter to the Sasol® Banana Plough™ is thus a reference to a plough which has curved leading and trailing faces, with the leading and trailing faces curving in the same direction, resembling to some extent a banana.

[0009] Both the short straight plough and the Sasol® Banana Plough™ are mounted on the upper rotatable grate component of the rotatable grate assembly at an angle to the direction of rotation, such that the leading face of the plough functions to scrape ash particles from an ash bed in a gasification chamber radially inwardly via a central ash discharge passageway or annulus into an ash chamber disposed below the rotatable grate assembly. Usually a number of ploughs, e.g. four ploughs, are symmetrically mounted on the rotatable grate assembly. Thus, during forward rotation of the rotatable grate assembly, the leading faces of each plough remove ash and crushed clinker particles from the gasifier by a scraping and cutting motion which causes the ash particles to follow a radially inward pathway from the wall of the gasifier to the central ash discharge annulus and into the ash chamber.

[0010] In the operation of the short straight plough, severe erosion on the ploughs and other components of the rotatable grate assembly has been observed. This led to the making of improvements in the materials of construction of the rotatable grate assembly, e.g. by introducing custom made hard-facing to mitigate erosion, as well as by introducing a number of changes in the geometry of the plough and other wear surfaces exposed to ash particles. These changes, amongst others, lead to the development of the Sasol® Banana Plough™.

[0011] The Applicant has subsequently learned that the mode of ash removal with the Sasol® Banana Plough™ causes erosion of certain components of the rotatable grate assembly, ploughs and gasifier walls exposed to ash. Discrete element modelling has shown surprisingly that the forward rotation of a rotatable grate assembly on which the Sasol® Banana Plough™ is mounted causes the leading face of a trailing plough to force ash particles onto the trailing face of a preceding plough. Thus, ash particles become compressed between the trailing face of a leading plough, the gasifier wall and the leading face of a trailing plough. This causes an accumulation and compression of ash particles between the two ploughs, which leads to outward forces on the gasifier

walls. Ash particles wedged between the ploughs and the gasifier wall cause erosion patterns on the gasifier walls and on the components of the grate assembly.

[0012] In an attempt to free the wedged ash particles, a grate may temporarily be operated in the reverse mode. This action however induces high torque loads on the drive systems which may eventually lead to mechanical equipment failure. Furthermore, erosion is increased during periods of reverse operation and ash extraction rates are also vastly reduced. Erosion leads to increased maintenance costs, equipment downtime and production loss. These are major operational inefficiencies caused by the inability of the ploughs of the prior art to remove ash in both the forward and the reverse operational modes of a rotatable grate assembly.

[0013] DD 267780 describes a solution for the crushing and discharge of ash mixed with slag as well as crushing of slag chunks to ensure continuous discharge from a pressurised coal gasifier. A combination element is used for discharging ash and slag. The element comprises a primary scraper, intermediate crusher or crusher jaw and secondary scraper. The scraper-crusher-scraper elements are mounted to a periphery of a rotating grate. Both the primary and secondary scrapers are mounted angularly relative to the periphery of the rotating grate. The primary scrapers appear to be slightly wedge-shaped in plan view, but narrows away from the axis of rotation.

[0014] DD 267550 describes a slag crusher for a pressurised coal gasifier. The slag crusher is used to crush and discharge solid compact slag chunks from a fixed bed pressure gasifier. DD 267550 aims to provide a device which crushes and discharges larger slag chunks without causing blockages and, when ash flow does occur, prevents uncontrolled egress of ash from the gasifier. An ash crushing assembly with two distinct parts are used. A stationary crushing element is fixed to a shell of the pressure gasifier, whereas ash removers are fixed to a rotating grate and rotatable about a central axis of the pressure gasifier. The stationary crushing element is formed by at least one conical surface inclined towards the axis of rotation. The radius of this surface decreases continually in the direction of rotation up to an inconsistency point. The inconsistency point is formed as an offset with sudden enlargement of radius. The ash removers are vertically oriented metal plates mounted in a radial direction from proximate a hollow shaft to the shell of the generator. The ash removers are curved along their longitudinal axes, i.e. they are curved in plan view.

[0015] U.S. Pat. No. 3,516,078 relates to the incineration of waste and to an incinerator apparatus in which refuse is consumed by burning over a stationary grate while simultaneously being agitated and conveyed along said grate by a series of conveyor ploughs. A combustor comprises broadly a perforated stationary grill located within a combustion chamber. A pair of troughs runs longitudinally along the grill and an endless drive chain is disposed in each trough. Ploughs are mounted on the centre of and along the length of each drive chain. In use, the chains pass about horizontally oriented axes of rotation passing through the centre of sprockets at each end of the grill. Each plough is rearwardly V-shaped, with a uniform linear downward and rearward sweep from a leading central apex to the outer tips of the wings thereof. The trailing edge of each plough is substantially vertical and the ploughs describe an elongate rectangular path with rounded ends, in use.

[0016] GB 909,931 discloses a scraper used to maintain the general shape of a top of a bed of solids which are passed upwardly through a retort zone. The scraper comprises a central shaft to which a horizontal platform is connected. A sloping scraper bar is connected to the platform and extends radially downwardly and outwardly therefrom. The scraper bar is angled to the horizontal. A horizontal scraper bar extends radially outwardly from the shaft to intersect with the scraper bar. The scraper is not wedge-shaped in plan view and the scraper bars are in the same vertical plane with co-planar faces.

[0017] WO 2006/061738 describes the components and the operation of a fixed bed coal gasifier. It discloses the use of the Sasol® Banana Plough™ in a fixed bed gasifier and its reverse mode of operation. The state of the art Sasol® Banana Plough™ is attached to a rotatable grate component such that the Sasol® Banana Plough™ passes with limited clearance over an ash collection surface. Ash is continuously withdrawn from the bottom of a gasification zone by rotation of the rotatable grate component and the Sasol® Banana Plough™ continuously discharges ash through an ash discharge passageway. WO 2006/061738 discloses the location and use of the Sasol® Banana Plough™ but is silent on the functional design of the Sasol® Banana Plough™. WO 2006/061738 also does not disclose any operational problems associated with the Sasol® Banana Plough™ or methods to solve them.

[0018] WO 1999/10094 specifically focuses on the grate component of a fixed bed coal gasifier and discloses information on the operation of the ash extraction assembly. It also discloses the use of the Sasol® Banana Plough™ which is operational in the reverse mode but does not disclose any information on its method of functioning.

[0019] U.S. Pat. No. 4,014,664 describes the components and operation of a rotary grate component assembly for a fixed bed coal gasifier, and the assembly appears to be similar to the grate assembly described in WO 2006/061738 and WO 1999/10094. U.S. Pat. No. 4,014,664 discloses that the scrapers are located on the periphery of the grate component and that the scrapers are operational in the reverse mode.

[0020] GB 389251 describes improvements in the mechanism of ash discharge in a Kerpely gas producer (Kerpely gas producers were often used for under firing coke ovens). GB 389251 discloses that scrapers are located at the periphery of a grate component and are arranged at an angle to the radius so that their rotation sweeps ash towards the centre of the grate component and into an ash discharge hopper.

[0021] U.S. Pat. No. 5,230,716 describes the components and operation of a reversible rotary grate component for a fixed bed coal gasifier. U.S. Pat. No. 5,230,716 discloses that scoops (ploughs) are located on an upper surface and near an apex of a conical grate component. In addition, each scoop is positioned at an angle to the radius of the gasification chamber and discharges ash from the central region of a gasification zone in the gasification chamber towards the peripheral region of the grate component to the ash discharge passageway. The location and operation of the scoop is therefore different to the state of the art Sasol® Banana Plough™ hereinbefore described.

[0022] U.S. Pat. No. 5,138,957 describes a bottom feed biomass gasification system that does not recirculate gases through a fixed bed. The gases are directed to a secondary heating chamber to maintain the desired operating temperature in a primary heating chamber. U.S. Pat. No. 5,138,957 discloses that the ash discharge system has four symmetri-

cally spaced paddles that are mounted on the periphery of a rotary band which rotates in a clockwise direction. The paddles comprise “generally radial front walls” which appear to be vertical. The paddle surface (radial front walls) sweeps the ash forwardly to an ash discharge passageway located between the chamber wall and ash discharge system. When clinkers are formed, they are broken down between the rear walls of the paddles and the walls of the reaction chamber. There is no mention of ash being lodged between the ploughs or erosion of the paddles or chamber walls in U.S. Pat. No. 5,138,957.

[0023] JP 2011083773 describes a process for the removal of melted ash produced in a biomass gasification process. A rotary scraper spans the horizontal surface of a floor of a reaction chamber. A “scratching finger” is connected to ends of the rotary scraper. Slag is directed forwardly by the “scratching finger” and after a single revolution of the rotary scraper; the slag is discharged through a discharge outlet located between the wall of the reaction chamber and the rotary scraper. The design of the “scratching finger” is undisclosed, however, a top view of the “scratching finger” leads to the conclusion that it is rectangular in shape with vertical faces.

[0024] GB 548082 describes a mechanism for keeping a rotating plough in a rotatable gas generator stationary. In normal operation the plough rotates with an ash pan and gas producer and does not turn out ash. When the mechanism is engaged and the plough is held stationary, ash will be removed from the producer. The ash plough itself is not shown nor is its design or specific functioning described.

[0025] CN 2518061 describes the extraction of block-shaped lime from a vertical lime kiln. The extraction device is rotatable and reversible and has six scrapers that are symmetrically located around its circumference. CN 2518061 discloses that the scrapers are “triangle” in shape and “scrapes the ash inwardly to an ash discharge tube”. The reverse mode of operation is required to “break the furnace conditions”.

[0026] CA 2188736 describes a fixed bed biomass gasification system, of which a primary chamber has a raised table for supporting the bed of biomass. The waste removal system consists of four ploughs that are symmetrically located at the periphery of a ring member on a rotating table and removes ash and waste from the chamber to accumulate in a channel that spans the chamber wall. The ash and waste material are then pushed to a waste aperture located in the floor of the chamber. Two of the ploughs are formed with scraping members that extend inwardly towards an apex of the table to scrape ash from the annular zone to the waste aperture. The scraping members also break up clinkers that form on the edge of the table. From a top view of the waste disposal system, it appears that the ploughs are fin-shaped and the scraping members are rectangularly shaped. CA 2188736 however does not provide any actual description of the design or shape of the ploughs. CA 2188736 is also silent on the reversibility of the waste disposal system.

[0027] GB 141056 relates to improvements to rotary grates employed in gas producers. The ash grates disclosed are conical in shape and attached to a top surface of the grate are radial projections with the leading surface of the projection rising rearwards from the leading edge. The front surfaces of the projections are convex and when the grate rotates will raise the combustible material and ash above the grate to prevent clinkering. These projections do not remove ash from

the ash bed. The conical shape of the grate also causes ash to move to the sides where an annulus is provided with stationary scrapers attached to the inside of vessel wall of the gas producer for ash removal. The ash grate projections in GB 141056 serve for clinker breaking and mixing above the grate. GB 141056 is silent on the functional design of the scraper itself. As ash is removed toward the periphery in GB 141056, no surface is provided for displacing ash radially inward.

[0028] EP 0159420 describes the gasification of solid fuel in a fixed bed system. There are two different sets of scrapers in the fixed bed gasifier for the extraction of ash. Radially extending walls continue downwards and extend inwardly into the chamber above a grate component to form “upper scraper members”. These scrapers are fixed to the chamber walls. In addition, there are a set of scrapers attached below the grate component that are described as “vertically reciprocable scrapers”. From the longitudinal section view of the gasification system, each “vertically reciprocable scraper” appears to span the left and right bottom surface of the grate and extends to the apex of the grate and central portion. The oscillating rotary motion of the grate component and the “vertically reciprocable scrapers” is controlled to be slightly more or less than the circumferential angle of 30°. The “vertically reciprocable scrapers” sweep ash over the periphery of the grate component to the ash discharge tube. The design aspects of the scrapers are undisclosed in EP 0159420.

[0029] WO 2013/110981 describes a rotary plough that at least ameliorates the problems of the prior art and which is able effectively to remove ash in both a forward and reverse, i.e. in a clockwise and anti-clockwise, mode of operation of a rotatable grate assembly.

[0030] As the rotary plough of WO 2013/110981 is an improvement over the prior art, it would be desirable in many instances to replace the current rotary ploughs (e.g. Sasol® Banana Ploughs™) of a rotatable grate assembly with the improved versions. Retrofitting a different rotary plough to an existing rotatable grate assembly may however not be that easy, particularly if it is desired not to make modifications to the upper rotatable grate component to which the rotary ploughs are to be mounted. There is thus a need for a rotary plough which shows the advantages of the rotary plough of WO 2013/110981 but which can readily be mounted to the upper rotatable grate component of a rotatable grate assembly, preferably without modifying the upper rotatable grate component at all, or at least not significantly.

[0031] According to one aspect of the invention, there is provided a solids handling equipment rotary plough, the rotary plough including

[0032] a metal body having a bottom and a top, and defining a pair of opposed spaced non-parallel elongate faces extending between the bottom and the top and from a first end to a second end of each opposed elongate face, the first end and the second end being spaced further from each other than the top and the bottom are spaced from each other providing each opposed elongate face with a length greater than a height, the opposed elongate faces being on opposite sides and facing away from a first imaginary vertical plane, each of said opposed elongate faces having at least two elongate major surfaces which are not co-planar, an upper, elongate, non-vertical, major surface being angled towards the first imaginary vertical plane to slope upwardly towards said first imaginary vertical plane at an angle of at least 1° to the vertical and a lower, elongate, vertical, major surface which is angled in a horizontal plane at an angle of at least 2° relative to the lower,

elongate, vertical, major surface of the other of the opposed elongate faces so that the first ends of the opposed elongate faces are closer to each other than the second ends of the opposed elongate faces are to each other rendering the opposed elongate faces diverging in a direction from the first ends towards the second ends, the first end of each elongate face being on a common side of a second imaginary vertical plane which is perpendicular to the first imaginary vertical plane and which is thus located between the first end and the second end of each elongate face, the opposed spaced non-parallel elongate faces being joined by a connector defining mounting means to mount the rotary plough to a rotatable grate component, said mounting means being located between said opposed non-parallel elongate faces.

[0033] By “major surfaces” of a face is meant the two largest surfaces of the face and thus there are no other surfaces on the face which are larger than the two major surfaces. Each major surface is typically planar.

[0034] In this specification, all relative directions and orientations of elements of the rotary plough or the metal body are intended to be determined when the rotary plough or the metal body is positioned such that its bottom is below its top and the lower major surfaces are held in a vertical plane, which is the operative position of the rotary plough in normal use.

[0035] The first imaginary vertical plane may be midway between the opposed elongate faces.

[0036] The metal body may include or may be in the form of at least two separable parts or components, a first part or component defining one of the non-parallel elongate faces and a second part or component defining the other of the non-parallel elongate faces, and with each of the first and second parts or components defining at least a portion of the connector.

[0037] The connector may be in the form of a web.

[0038] The rotary plough may include joining means to join the first and second parts of the metal body together. The joining means may be configured to join the first and second parts temporarily so that, if desired, the first and second parts can be separated.

[0039] In one embodiment of the invention, the joining means includes a fastener and a joint aperture in the portion of the connector defined by each of the first and second parts, the first and second parts being configured such that the joint apertures can be brought into alignment, with said fastener extending through the joint apertures.

[0040] The fastener and/or the joint apertures may be configured to enable the fastener to be inserted from the top towards the bottom, i.e. in a downwards direction, into the aligned joint apertures.

[0041] The fastener may be in the form of a pin. In use, the pin, and in particular a head thereof, can be tack welded to the metal body. In order to remove the pin, the welding is simply removed e.g. by grinding it away.

[0042] The connector portion of one of the first and second parts or components may define a joint seat to receive and seat a joint portion of the connector portion of the other of the second and first parts or components. Typically, the joint apertures are located in said joint seat and in said joint portion respectively.

[0043] The joint seat and the joint portion may be configured such that they lock the first part or component and the

second part or component together, preventing relative rotation between the first part or component and the second part or component about the fastener.

[0044] If desired, both the first part and the second part may each have a connector portion which defines a joint seat to receive and seat a joint portion of the connector portion of the other of the second and first parts. The joint seat and joint portion of a connector portion may thus be defined by or may be the same part of said connector portion.

[0045] The mounting means may include or may be in the form of at least one mounting aperture extending through the connector between the top and the bottom of the metal body, typically in a vertical direction. Preferably, the mounting means includes or is in the form of at least two spaced mounting apertures, e.g. three spaced mounting apertures.

[0046] In one embodiment of the invention, one of the first and second parts includes or defines two of said mounting apertures and the other of said second and first parts defines a single mounting aperture.

[0047] The mounting apertures may be positioned and spaced to fall on an arc of a single segment of an imaginary circle. In other words, the arc is common to the mounting apertures. In one embodiment, said imaginary circle may have a diameter of between about 2000 mm and about 4000 mm, preferably between about 2600 mm and about 3400 mm, most preferably between about 2800 mm and about 3200 mm, e.g. about 3 060 mm. In another embodiment, said imaginary circle may have a diameter of between about 4000 mm and about 5000 mm, preferably between about 4200 mm and about 4800 mm. As will be appreciated, advantageously, with such a diameter of the imaginary circle, the rotary plough can easily be mounted close to a periphery of a rotatable grate component or rotary component of a rotatable grate assembly with a similar diameter.

[0048] Said second imaginary vertical plane may be located between the mounting means on one side thereof and the joining means on the other side thereof.

[0049] The first ends of the elongate faces and the mounting means may be located on the same side of said second imaginary vertical plane.

[0050] The connector may define at least one mounting seat to receive and seat a portion of a rotatable grate component to which the rotary plough is to be mounted.

[0051] The mounting seat may be defined in or on an upper surface of the connector. The upper surface of the connector may thus be irregular, defining recesses or depressions or raised areas. The mounting seat may thus be in the form of a recess or depression in the connector.

[0052] When the metal body includes or is in the form of two separable parts, both the first and the second part may include or define a mounting seat to receive and seat a portion of a rotatable grate component to which the rotary plough is to be mounted.

[0053] The mounting apertures may be located in said mounting seats.

[0054] The connector may define a wall along at least a portion of a periphery of at least one of the mounting seats so that said wall abuts against said portion of a rotatable grate component received and seated in use by said mounting seat. The wall may be located on the top of the metal body. The wall may be formed by a depression or recess in the connector. Instead, or in addition, the wall may be formed by a raised area of the connector.

[0055] The connector may define a projection that projects towards said first ends of the elongate faces. In use, said projection can thus be received in a recess or notch or serration or gouge or the like in a periphery of a rotatable grate component to which the rotary plough is mounted.

[0056] The projection may be defined by said wall.

[0057] The connector may be absent between a portion of one opposed elongate face and a portion of the other opposed elongate face.

[0058] In one embodiment of the invention, the connector is absent between opposed end portions of the opposed elongate faces which include or define said first ends of the opposed elongate faces. A void may thus be defined between said opposed end portions.

[0059] A periphery of the void, in other words a periphery of the connector extending between the opposed elongate faces, may define a formation to receive a complementary projection of a rotatable grate component to which the rotary plough is to be mounted in use. The formation and the projection may be V-shaped.

[0060] A bottom of the connector may define a recessed carrier seat to receive and seat a portion of a plough carrier so that in use a portion of the connector is sandwiched between the plough carrier and a rotatable grate component to which the rotary plough and the plough carrier are mounted. The recessed carrier seat may be defined along at least one portion of said periphery of said void, i.e. along a periphery of the connector extending between the opposed elongate faces.

[0061] In one embodiment of the invention, each of said first and second parts of the metal body define a portion of said recessed carrier seat, said portions being spaced. Said portions of the carrier seat may be aligned or coincide with and may be beneath the mounting seats on top of the connector.

[0062] The metal body may be of hardened steel. Alternatively, the metal body may be of casting steel, e.g. a specially modified heat resistant iron-chromium-nickel alloy of ASTM A297 Grade HF. The metal body may thus include a casting.

[0063] At least the major surfaces of the opposed elongate faces may be clad in a specially hardened material, e.g. a hardfacing such as PRO 100 (trade name) or Lincor 60 (trade name) hardfacing. Preferably, also portions of the top and the bottom of the connector are clad in a hardened material.

[0064] The upper major surface and the lower major surface of an opposed elongate face may share a common periphery or edge between them. In other words, the upper major surface and the lower major surface of an opposed elongate face may be adjacent to and bordering each other.

[0065] The common periphery or edge of the upper major surface and the lower major surface of an opposed elongate face may be linear and may extend downwardly towards the bottom, in a direction away from said first end.

[0066] The common periphery or edge of the upper and lower major surfaces of an opposed elongate face may be angled in a horizontal plane at an angle relative to the lower, elongate, vertical, major surface of the other of the opposed elongate faces which coincides with the angle at which the lower major surface is angled in a horizontal plane relative to the lower, elongate, vertical, major surface of the other of the opposed elongate faces. In other words, the common periphery or edge of the upper and lower major surfaces and the lower major surface may be in a common vertical plane.

[0067] The common periphery or edge of the upper and lower major surfaces of an opposed elongate face may define at least a portion of a top periphery of the lower major surface of the opposed elongate face

[0068] The common periphery or edge of the upper and lower major surfaces of an opposed elongate face may define at least a portion of a bottom periphery of the upper major surface of the opposed elongate face.

[0069] The angle of the upper major surface of an opposed elongate face to the vertical may be in the range of from about 1° to about 35°, e.g. about 15°.

[0070] The angle between the lower major surfaces of the opposed elongate faces in a horizontal plane may be in the range of from about 2° to about 36°, e.g. about 12°.

[0071] The opposed elongate faces of the body of the rotary plough may be mirror images of each other. The first imaginary vertical plane may be a mirror plane or plane of symmetry for the opposed elongate faces so that the opposed elongate faces are mirrored about said first imaginary vertical plane, but are not parallel to said first imaginary vertical plane.

[0072] Each opposed elongate face may be defined by a plough portion of the metal body. The plough portions may be generally wedge-shaped in plan view, thickening from the first end towards the second end of the opposed elongate face defined by the plough portion.

[0073] An end portion of a plough portion which includes or which defines said second end of the opposed elongate face may have an increased height, i.e. increased distance between the bottom and the top, compared to an end portion of the plough portion which includes or which defines said first end of the opposed elongate face.

[0074] If desired, a bottom or bottom periphery of a plough portion may drop down in a direction from the first end towards the second end of the opposed elongate face.

[0075] The plough portion may end at the second end in a rounded toe curving upwardly from the bottom to the top of the plough portion.

[0076] A portion of the connector extending between end portions of the plough portions which define said second ends of the opposed elongate faces may have a reduced height or vertical thickness compared to said end portions of the plough portions which define said second ends of the opposed elongate faces. Said portion of the connector extending between said end portions of the plough portions which define said second ends of the opposed elongate faces may thus define a lower terrace or step.

[0077] The joint seat and the joint portion of a connector portion may form part of the lower terrace or step.

[0078] The invention extends to a solids handling equipment rotary plough part or component, the rotary plough part or component including

[0079] a metal body having a bottom and a top, and defining an elongate face extending between the bottom and the top and from a first end to a second end of the elongate face; and

[0080] a connector extending away from said elongate face to connect and join the plough part or component to another plough part or component which also has an elongate face to provide a rotary plough with opposed elongate faces that face away from each other,

[0081] the first end and the second end of said elongate face being spaced further from each other than the top and the bottom are spaced from each other providing the elongate face with a length greater than a height, the elongate face

having at least two elongate major surfaces which are not co-planar, an upper, elongate, non-vertical, major surface being angled towards the connector at an angle of at least 1° to the vertical and a lower, elongate, vertical, major surface, an angle between the lower, elongate, vertical, major surface and the upper, elongate, non-vertical, major surface thus being greater than 180°,

[0082] the connector being at a substantially right angle to the lower, elongate, vertical, major surface where said angle is taken in a vertical plane perpendicular to the lower, elongate, vertical, major surface and the connector defining mounting means to mount the rotary plough part or component to a rotatable grate component.

[0083] By “substantially right angle” is meant an angle between about 84° and about 96°, preferably between about 86° and about 94°, more preferably between about 88° and about 92°, most preferably between about 89° and about 91°, e.g. about 90°.

[0084] The connector may include or may define joining means to connect and join the plough part or component to said another plough part or component which also has an elongate face to provide a rotary plough with opposed elongate faces that face away from each other. The rotary plough formed by connecting and joining the plough part or component to said another plough part or component which also has an elongate face may be as hereinbefore described.

[0085] The joining means may be configured to join the plough part and said another plough part temporarily so that, if desired, the plough part and said another plough part can be separated.

[0086] In one embodiment of the invention, the joining means includes a joint aperture in the connector.

[0087] The connector may define a joint seat to receive and seat a joint portion of a connector of said another plough part. Typically, the joint aperture is located in said joint seat.

[0088] The mounting means may include or may be in the form of at least one mounting aperture defined by or extending through the connector between the top and the bottom, typically in a vertical direction.

[0089] The connector may define at least one mounting seat to receive and seat a portion of a rotatable grate component to which the rotary plough part or component is to be mounted.

[0090] The mounting seat may be defined in or on an upper surface of the connector. The upper surface of the connector may thus be irregular, defining recesses or depressions or raised areas. The mounting seat may thus be in the form of a recess or depression in the connector.

[0091] The mounting aperture or mounting apertures may be located in said mounting seat.

[0092] The connector may define a wall along at least a portion of a periphery of the mounting seat so that said wall abuts against said portion of a rotatable grate component received and seated in use by said mounting seat. The wall may be located on the top of the metal body. The wall may be formed by a depression or recess in the connector. Instead, or in addition, the wall may be formed by a raised area of the connector.

[0093] The connector may define a projection that projects towards said first end of the elongate face. In use, said projection can thus be received in a recess or notch or serration or gouge or the like in a periphery of a rotatable grate component to which the solids handling equipment rotary plough component or part is mounted.

[0094] The projection may be defined by said wall.

[0095] A periphery of the connector on a side of the connector facing towards said first end of said elongate face may define a formation to receive a complementary projection of a rotatable grate component to which the solids handling equipment rotary plough is to be mounted in use.

[0096] A bottom of the connector may define a recessed carrier seat to receive and seat a portion of a plough carrier so that in use a portion of the connector is sandwiched between the plough carrier and a portion of a rotatable grate component to which the rotary plough part or component is mounted, with the plough carrier also being mounted to said portion of the rotatable grate component or forming part of said portion of the rotatable grate component. The recessed carrier seat may be defined along at least one portion of said periphery of the connector.

[0097] The recessed carrier seat may be aligned or coincide with and may be beneath the mounting seat on top of the connector.

[0098] The metal body of the rotary plough part or component may be of hardened steel. Alternatively, the metal body may be of casting steel, e.g. a specially modified heat resistant iron-chromium-nickel_alloy of ASTM A297 Grade HF. The metal body may thus include a casting.

[0099] At least the major surfaces of the elongate face may be clad in a specially hardened material, e.g. a hardfacing such as PRO 100 (trade name) Lincor 60 (trade name) hardfacing. Preferably, also portions of the top and the bottom of the connector are clad in a hardened material.

[0100] The upper major surface and the lower major surface of the elongate face of the rotary plough part or component may share a common periphery or edge between them. In other words, the upper major surface and the lower major surface of the elongate face may be adjacent to and bordering each other.

[0101] The common periphery or edge of the upper major surface and the lower major surface of the elongate face may be linear and may extend downwardly towards the bottom, in a direction away from said first end.

[0102] The common periphery or edge of the upper and lower major surfaces and the lower major surface may be in a common vertical plane.

[0103] The common periphery or edge of the upper and lower major surfaces of the elongate face may define at least a portion of a top periphery of the lower major surface of the elongate face

[0104] The common periphery or edge of the upper and lower major surfaces of the elongate face may define at least a portion of a bottom periphery of the upper major surface of the elongate face.

[0105] The angle of the upper major surface of the elongate face to the vertical may be in the range of from about 1° to about 35°, e.g. about 15°.

[0106] The elongate face may be defined by a plough portion of the metal body. The plough portion may be generally wedge-shaped in plan view, thickening from the first end towards the second end of the elongate face defined by the plough portion.

[0107] An end portion of the plough portion which includes or which defines said second end of the elongate face may have an increased height, i.e. increased distance between the bottom and the top, compared to an end portion of the plough portion which includes or which defines said first end of the elongate face. If desired, a bottom or bottom periphery of the

plough portion may drop down in a direction from the first end towards the second end of the elongate face.

[0108] Preferably, the elongate face may end at the second end in a rounded toe curving upwardly from the bottom to the top of the plough portion.

[0109] A portion of the connector nearer to the second end than to the first end of the elongate face may have a reduced height or vertical thickness compared to said end portion of the plough portion which defines said second end of the elongate face. Said portion of the connector may thus define a lower terrace or step.

[0110] The joint seat and the joint portion of the connector may form part of the lower terrace or step.

[0111] According to another aspect of the invention, there is provided a rotatable grate assembly for a gasifier for gasifying carbonaceous material producing ash, the rotatable grate assembly including

[0112] a rotary component configured to rotate about a vertical axis of rotation in at least one direction; and

[0113] a plurality of rotary ploughs mounted to the rotary component to rotate together with the rotary component in a horizontal plane about said axis of rotation to describe a circle,

[0114] at least one of the rotary ploughs including a metal body having a bottom and a top, and defining a pair of opposed spaced non-parallel elongate faces extending between the bottom and the top and from a first end to a second end of each opposed elongate face, the first end and the second end being spaced further from each other than the top and the bottom are spaced from each other providing each opposed elongate face with a length greater than a height, the opposed elongate faces being on opposite sides and facing away from a first imaginary vertical plane, each of said opposed elongate faces having at least two elongate major surfaces which are not co-planar, an upper, elongate, non-vertical, major surface being angled towards the first imaginary vertical plane to slope upwardly towards said first imaginary vertical plane at an angle of at least 1° to the vertical and a lower, elongate, vertical, major surface which is angled in a horizontal plane at an angle of at least 2° relative to the lower, elongate, vertical, major surface of the other of the opposed elongate faces so that the first ends of the opposed elongate faces are closer to each other than the second ends of the opposed elongate faces are to each other, the first end of each elongate face being on a common side of a second imaginary vertical plane which is perpendicular to the first imaginary vertical plane and which is thus located between the first end and the second end of each elongate face, the opposed spaced non-parallel elongate faces being joined by a connector defining mounting means mounting the rotary plough to said rotary component, said mounting means being located between said opposed non-parallel elongate faces.

[0115] In this specification, the term “component” is intended to include an assembled component including more than one part, such as a rotatable grate component comprising a number of parts assembled to form the grate component.

[0116] Said at least one rotary plough may be as hereinbefore described.

[0117] The first imaginary vertical plane may coincide with a radius of said circle described by the rotary ploughs mounted to the rotary component.

[0118] Preferably, the rotary component is configured to rotate in two directions, i.e. both clockwise and counter-

clockwise. The rotary component may thus be configured for rotation in both an operative forward direction and an operative reverse direction.

[0119] The rotary component may be an upper rotatable grate component, the rotatable grate assembly further including a lower rotatable support structure fastened to the upper rotatable grate component for rotation together with the upper rotatable grate component, the lower rotatable support structure being configured to be drivingly rotated (preferably selectively clockwise and counter-clockwise) about an axis of rotation which coincides with said axis of rotation of the upper rotatable grate component.

[0120] Said first ends of the opposed elongate faces typically are closer to the axis of rotation of the rotary component than said second ends, and closer to each other than the second ends are to each other. In other words, said at least one rotary plough typically is mounted to the rotary component to extend radially away from the axis of rotation, with the second ends being radially distal from the axis of rotation and with the rotary plough in plan view widening in a radial direction away from the axis of rotation.

[0121] The rotary component may be in the form of a circular disc or in the form of an annular body, with the rotary ploughs being mounted adjacent a radially outward periphery of the rotary component. The radially outward periphery may be gouged or notched or serrated or may define a plurality of recesses.

[0122] A portion of said at least one rotary plough may be beneath the rotary component and a portion of said at least one rotary plough may project out from underneath the rotary component, e.g. in a radial direction away from the axis of rotation.

[0123] The wall of the connector extending along at least a portion of a periphery of at least one of the mounting seats may abut against a portion, typically a peripheral portion, of the rotary component received and seated by the mounting seat of the connector.

[0124] The projection defined by the connector may be received in one of said recesses or notches or serrations or gouges or the like in the periphery of the rotary component to which said at least one rotary plough is mounted.

[0125] The rotatable grate component or rotary component may define a complementary projection to the formation defined by the periphery of said void in said at least one rotary plough, i.e. by the periphery of the connector extending between the opposed elongate faces. The complementary projection may depend downwardly. The complementary projection may be received in said formation defined by the periphery of said void. As hereinbefore indicated, the formation and the projection may be V-shaped.

[0126] In this specification, unless clearly intended otherwise in the context used, the term “radius” or “radially” is used to describe a direction or position relative to or coinciding with the radius of a circle in use described by the rotary ploughs when rotating in a plane through which said axis of rotation extends. Thus, a radially outer or radially outward object or part is further away from said axis of rotation than a radially inner or radially inward object or part. It is however to be noted that “outwardly” means outwardly away from said axis of rotation, although not necessarily along a radius of said circle, unless so specified, with the term “inwardly” having an opposite meaning.

[0127] Said at least one rotary plough may be mounted to said rotary component by means of fasteners passing through

apertures in the rotary component and through the mounting apertures defined by the connector of said at least one rotary plough.

[0128] The rotatable grate assembly may include one or more plough carriers attached to or forming part of a bottom of the rotary component. At least one plough carrier may be associated with said at least one rotary plough. The plough carrier may engage said at least one rotary plough along said at least one carrier seat of said at least one rotary plough. A portion of the connector of said at least one rotary plough may thus be sandwiched between the plough carrier and the bottom of the rotary component.

[0129] The plough carrier may define apertures that are in alignment with the mounting apertures defined by the connector of said at least one rotary plough and with the apertures in the rotary component. The fasteners may thus extend through or into the plough carrier as well.

[0130] The fasteners may be in the form of pins. The pins may be tack welded to the plough carrier.

[0131] The rotatable grate component or rotary component may have an upwardly inwardly tapering outer surface. The upwardly inwardly tapering outer surface may be staggered or stepped when seen in vertical cross-section, defining vertically and radially spaced terraces. The terraces may be covered by shield plates to protect the rotatable grate component or rotary component from abrasive material, e.g. ash.

[0132] The rotary ploughs may be equiangularly spaced. Thus, for example, when only two rotary ploughs are present, they may be about 180° apart, when three rotary ploughs are present, they may be about 120° apart, when four rotary ploughs are present, they may be about 90° apart, and when six rotary ploughs are present, they may be about 60° apart. It may however be that the arrangement of the rotary ploughs is not symmetrical due to construction constraints (other components in the way, etc.), particularly when said at least one rotary plough of the invention is retrofitted to an existing rotatable grate assembly. Large variations in spacing between rotary ploughs, e.g. up to 60° variation, may be employed.

[0133] It is expected that up to six rotary ploughs may be mounted to the rotary component. Preferably, all of the rotary ploughs are rotary ploughs in accordance with the invention.

[0134] According to a further aspect of the invention, there is provided a gasifier for gasifying carbonaceous material, the gasifier including a rotatable grate assembly as hereinbefore described, the rotatable grate assembly being mounted within a gasification chamber defined by a gasification vessel.

[0135] The rotatable grate assembly may include a lower rotatable support structure as hereinbefore described. The lower rotatable support structure of the grate assembly may be connected to drive means.

[0136] The gasifier may be a fixed bed gasifier, in particular a fixed bed dry bottom gasifier.

[0137] The invention extends to use of the gasifier as hereinbefore described to gasify coal, waste or biomass, or a combination of two or more of coal, waste and biomass. Typically however, the gasifier is used to gasify coal at a pressure of between 5 bar(g) and 100 bar(g) and at a temperature of between about 400° C. and about 1600° C.

[0138] The rotatable grate component or rotary component typically has a vertical dimension and a radial direction and is rotatable about a vertical axis of an ash discharge outlet of the gasification chamber, with a lower periphery of the rotatable

grate component or rotary component being below an apex or upper end of the rotatable grate component or rotary component.

BRIEF DESCRIPTION OF THE DRAWINGS

[0139] The invention will now be further described, by way of example, with reference to the accompanying diagrammatic drawings in which:

[0140] FIG. 1 shows a vertically sectioned view of a rotatable grate assembly installed in a fixed bed dry bottom gasifier;

[0141] FIG. 2 shows a bottom view of a rotatable grate assembly in accordance with the invention;

[0142] FIG. 3 shows a three-dimensional view of a solids-handling equipment rotary plough in accordance with the invention;

[0143] FIG. 4 shows a top view of the rotary plough of FIG. 3;

[0144] FIG. 5 shows a bottom view of the rotary plough of FIG. 3;

[0145] FIG. 6 shows a front view of the rotary plough of FIG. 3;

[0146] FIG. 7 shows a rear view of the rotary plough of FIG. 3;

[0147] FIG. 8 shows a left side view of the rotary plough of FIG. 3;

[0148] FIG. 9 shows a right side view of the rotary plough of FIG. 3;

[0149] FIG. 10 shows a three-dimensional view of a first solids-handling equipment rotary plough component of the rotary plough of FIG. 3;

[0150] FIG. 11 shows a top view of the component of FIG. 10;

[0151] FIG. 12 shows a bottom view of the component of FIG. 10;

[0152] FIG. 13 shows a front view of the component of FIG. 10;

[0153] FIG. 14 shows a rear view of the component of FIG. 10;

[0154] FIG. 15 shows a left side view of the component of FIG. 10;

[0155] FIG. 16 shows a right side view of the component of FIG. 10;

[0156] FIG. 17 shows a three-dimensional view of a second solids-handling equipment rotary plough component of the rotary plough of FIG. 3;

[0157] FIG. 18 shows a top view of the component of FIG. 17;

[0158] FIG. 19 shows a bottom view of the component of FIG. 17;

[0159] FIG. 20 shows a front view of the component of FIG. 17;

[0160] FIG. 21 shows a rear view of the component of FIG. 17;

[0161] FIG. 22 shows a left side view of the component of FIG. 17;

[0162] FIG. 23 shows a right side view of the component of FIG. 17; and

[0163] FIG. 24 shows a three-dimensional view of a portion of a rotatable grate assembly in accordance with the invention.

DETAILED DESCRIPTION

[0164] With reference to FIG. 1 of the drawings, reference numeral 10 generally indicates a rotatable grate assembly installed in a gasification vessel 100 of a fixed bed dry bottom gasifier. The gasification vessel 100 defines a gasification chamber 102 (i.e. a pressure vessel) within which the rotatable grate assembly 10 is housed. The gasification chamber 102 has a wall 18.

[0165] The rotatable grate assembly 10 comprises an upper rotatable grate component 11 (also known as a gasifier grate), connected to a lower rotatable support structure 12 by a plurality of connecting bolts 15. The lower rotatable support structure 12 is drivingly connected to a ring gear 13 which is in turn connected through a gearbox and drive shaft to an electric motor (not shown). In use, the electric motor and gearbox are used to rotate the rotatable components 11, 12 and 13 of the rotatable grate assembly 10, selectably either in a clockwise or in a counter-clockwise direction, with one of these directions being a normal direction of operation and the other being a reverse direction of operation.

[0166] The rotatable components 11, 12 and 13 are supported by a stationary support structure 14 above an ash discharge outlet or passageway 20 of the gasification vessel 100. Rotary metal ash ploughs 17 are connected to a radially outermost periphery of the upper rotatable grate component 11. The ploughs 17 are used to scrape ash from an ash bed within the gasification chamber 102 through an ash discharge annulus 19 which is defined between the outer periphery of the upper rotatable grate component 11 and the wall 18 of the gasification chamber 102. In principle, the ploughs 17 may be of the short straight type or the Sasol® Banana Plough™ as hereinbefore described, or one or more of the ploughs 17 may be the improved solids-handling equipment rotary plough according to the invention. Conveniently, the upper rotatable grate component 11 is configured to allow the ploughs 17 to be readily interchangeable.

[0167] The upper rotatable grate component 11 is provided with shield plates 22, arranged in terrace fashion.

[0168] In use, the rotatable grate assembly 10 is rotated about a vertical axis of rotation 21, which corresponds with the centre line of the ash discharge passageway 20 which is also the centre line of the rotatable grate assembly 10. Coal is fed batch-wise into the top of the gasifier (not shown) and gasification agent (i.e. steam and oxygen) is fed into a lower portion of the gasification chamber 102 through gasification agent outlets 23 underneath lower edges of outer shield plates 22, thereby to gasify coal located in a slowly downwardly moving bed within the gasification chamber 102. Ash is continuously withdrawn from the bottom of the gasification chamber 102 through the ash discharge annulus 19 provided between the wall 18 of the gasification chamber 102 on the one hand and the upper rotatable grate component 11 on the other hand, and through the ash discharge passageway 20. The ploughs 17 rotate with the upper rotatable grate component 11 thereby discharging ash by scraping it through the ash discharge annulus 19. As the upper rotatable grate component 11 rotates, clinker crushing is performed between the shield plates 22 of the upper rotatable grate component 11 and the wall 18 of the gasification chamber 102. At times, in an attempt to free wedged ash particles, the upper rotatable grate assembly 11 may temporarily be operated in a reverse mode by rotating it in the reverse direction of operation.

[0169] With reference to FIGS. 3 to 9 of the drawings, reference numeral 200 generally indicates an improved sol-

ids-handling equipment rotary plough in accordance with the invention. The rotary plough 200 is in the form of an assembly comprising a first solids-handling equipment rotary plough component 300 (see FIGS. 10 to 16) and a second solids-handling equipment rotary plough component 400 (see FIGS. 17 to 23). Each of the rotary plough components 300, 400 weighs about 120 to 130 kg.

[0170] The rotary plough components 300, 400 are in the form of metal-clad, cast metal bodies so that the assembled rotary plough 200 thus has a metal body having a bottom 202 and a top 204. The assembled rotary plough 200 is thus also used in this orientation, i.e. with the bottom 202 below the top 204, typically on opposite sides of a horizontal plane.

[0171] The first rotary plough component 300 defines an elongate face 302 extending between the bottom 202 and the top 204 and from a first end 304 to a second end 306. Similarly, the second rotary plough component 400 defines an elongate face 402 extending between the bottom 202 and the top 204 and from a first end 404 to a second end 406.

[0172] The elongate faces 302, 402 are opposed, facing away from each other, spaced from each other and non-parallel.

[0173] The first end 304 and the second end 306 of the elongate face 302 are spaced further from each other than the top 204 and the bottom 202 are spaced from each other providing the elongate face 302 with a length (taken between the first end 304 and the second end 306) greater than a height (which is variable and which is taken between the bottom 202 and the top 204). Similarly, the first end 404 and the second end 406 of the elongate face 402 are spaced further from each other than the top 204 and the bottom 202 are spaced from each other providing the elongate face 402 with a length greater than a height.

[0174] The opposed elongate faces 302, 402 are on opposite sides and facing away from a first imaginary vertical plane 206 (see FIG. 3). Conveniently, the first imaginary vertical plane may be more or less midway between the opposed elongate faces 302, 402, as can be seen in FIG. 4.

[0175] The elongate face 302 has two elongate planar major surfaces which are not co-planar. An upper, elongate, non-vertical, planar major surface 308 is angled towards the first imaginary vertical plane 206 to slope upwardly towards the first imaginary vertical plane 206 at an angle of about 15° to the vertical (see FIGS. 13 and 14). A lower, elongate major surface 310 is a vertical planar surface.

[0176] Similarly, the elongate face 402 has an upper, elongate, non-vertical, major planar surface 408 which is angled towards the first imaginary vertical plane 206 to slope upwardly towards the first imaginary vertical plane 206 at an angle of about 15° to the vertical (see FIGS. 20 and 21). A lower, elongate, major planar surface 410 is vertical.

[0177] The first ends 304, 404 are closer to each other (in a horizontal plane) than the second ends 306, 406 are to each other, rendering the opposed elongate faces 302, 402 diverging in a direction from the first ends 304, 404 towards the second ends 306, 406, as can be seen in FIG. 4. The lower planar vertical major surface 310 and the lower planar vertical major surface 410 are thus angled in a horizontal plane at an angle of about 12° relative to each other (and respectively at an angle of about 6° relative to the first imaginary vertical plane 206), as can clearly be deduced from FIG. 4.

[0178] The first ends 304, 404 of the elongate faces 302, 402 are on a common side of a second imaginary vertical plane 208. The second imaginary vertical plane 208 is thus

located between the first end **304** and the second end **306** of the elongate face **302**, and also between the first end **404** and the second end **406** of the elongate face **402**, and is perpendicular to the first imaginary vertical plane **204**.

[0179] The elongate faces **302**, **402** are joined by a web-like connector **210**, which is in turn defined by the joined first rotary plough component **300** and the second rotary plough component **400**. The connector **210** defines mounting means in the form of mounting apertures **212**, **214** and **216** to mount the assembled rotary plough **200** to a rotatable grate component, such as the upper rotatable grate component **11** shown in FIG. 1 of the drawings and the rotatable component **504** shown in FIG. 2 of the drawings. As can be clearly seen in FIG. 3, the mounting means, in the form of the mounting apertures **212**, **214** and **216**, is located between the opposed non-parallel or diverging elongate faces **302** and **402**.

[0180] Joining means joins the first rotary plough component **300** and the second rotary plough component **400** together to form the assembled rotary plough **200**. The joining means comprises a fastener, in the form of a pin **218**, a joint aperture **312** in a portion of the connector **210** defined by the first rotary plough component **300** (see FIGS. 5 and 11 to 12), and a joint aperture **412** in a portion of the connector **210** defined by the second rotary plough component **400** (see FIGS. 3 and 17 to 19). As will be appreciated, as the joining means is in the form of apertures **312** and **412** and a pin **218**, the joining means is configured to join the first rotary plough component **300** and the second rotary plough component **400** temporarily so that, if desired, the first rotary plough component **300** and the second rotary plough component **400** can easily be separated. In order to join the first rotary plough component **300** and the second rotary plough component **400**, the pin **218** is inserted from the top **204** towards the bottom **202** after the joint apertures **312** and **412** have been brought into alignment. The pin **218**, and in particular a head thereof, is then typically tack-welded to ensure that it stays in place during use of the rotary plough **200**.

[0181] A portion of the connector **210** defined by the first rotary plough component **300** defines a joint seat **314**. Complementarily a portion of the connector **210** defined by the second rotary plough component **400** defines a joint portion **414**. The joint aperture **312** is located in the joint seat **314** and the joint aperture **412** is located in the joint portion **414**. When the first rotary plough component **300** and the second rotary plough component **400** are joined together, the joint seat **314** receives and seats the joint portion **414**. As will be appreciated, when the rotary plough **200** is flipped over so that the bottom **202** is at the top, the joint portion **414** rather defines a joint seat and the joint seat **314** then rather defines a joint portion. It is thus accurate to describe the joint seat **314** as also being a joint portion and the joint portion **414** as also being a joint seat.

[0182] The joint seat **314** is defined by a recess in a portion of the connector **210** defined by the first rotary plough component **300**. The recess has a wall **316** which forms a right angled corner **318** (see FIG. 4). In turn, the joint portion **414** has a right angled corner **418** which is snugly received in the right angled corner **318**. The joint seat **314** and the joint portion **414** are thus configured so that they lock the first rotary plough component **300** and the second rotary plough component **400** together, preventing relative rotation between the first rotary plough component **300** and the second rotary plough component **400** about the pin **218**.

[0183] The mounting apertures **212**, **214** and **216**, defining the mounting means, extend through the connector **210** between the top **204** and the bottom **202** in a vertical direction. The mounting apertures **212** and **214** are defined by the portion of the connector **210** defined by the first rotary plough component **300**, whereas the mounting aperture **216** is defined by a portion of the connector **210** defined by the second rotary plough component **400**. The mounting aperture **216** has a larger diameter than the mounting apertures **212** and **214**, which are sized the same. The mounting apertures **212**, **214** and **216** are positioned and spaced to fall on an imaginary circle with a diameter of about 3060 mm. As can be clearly seen in FIG. 3 and FIG. 4 of the drawings, the mounting apertures **212**, **214** and **216** are conveniently located on one side of the second imaginary vertical plane **208** whereas the pin **218**, joint aperture **312** and joint aperture **412** are located on the opposite side of the second imaginary vertical plane **208**. Also the first ends **304**, **404** are located on the same side of the second imaginary vertical plane **208** as the mounting apertures **212**, **214** and **216**.

[0184] The connector **210** defines a mounting seat **220** to receive and seat a peripheral portion of a rotatable grate component (e.g. a portion of a shoe of a complimentary shape) to which the rotary plough **200** is mounted, such as the upper rotatable grate component **11**. The mounting seat **220** is defined in the top **204**, i.e. in or on an upper surface of the connector **210**. The mounting seat **220** is in the form of a recess or depression in the connector **210**. As will be noted, a portion of the mounting seat **220** is defined by the first rotary plough component **300** and a portion of the mounting seat **220** is defined by the second rotary plough component **400**. These portions of the mounting seat **220** are spaced. The mounting apertures **212** and **214** are located in the portion of the mounting seat **220** defined by the first rotary plough component **300** whereas the mounting aperture **216** is defined by the portion of the mounting seat **220** defined by the second rotary plough component **400**.

[0185] The connector **210** defines a wall **222** along a portion of a periphery of the portion of the mounting seat **220** defined by the first rotary plough component **300**. In use, the wall **222** abuts against a peripheral portion of a rotatable grate component (e.g. a portion of a shoe of a rotatable grate component) received and seated by said portion of the mounting seat **220**. The wall **222** is located on the top **204** and is formed as a result thereof that the portion of the mounting seat **220** defined by the first rotary plough component **300** is in the form of a depression or recess in the connector **210**.

[0186] The connector **210** defines a V-shaped projection **224** that projects towards the first ends **304**, **404**. In use, the projection **224** is received in a V-shaped recess or notch or serration or the like in a periphery of a rotatable grate component (e.g. in a periphery of a shoe of a rotatable grate component), such as the upper rotatable grate component **11** to which the rotary plough **200** is mounted. The projection **224** is defined by the wall **222**.

[0187] As can be clearly seen in the drawings, the connector **210** is absent between portions of the opposed elongate faces **302**, **402** which include or define the first ends **304**, **404**. A void **226** is thus defined between the opposed elongate faces **302**, **402**.

[0188] A periphery of the void **226**, defined by a periphery of the connector **210** extending between the opposed elongate faces **302**, **402**, defines a V-shaped recess **228** (see FIG. 4). In use, the V-shaped recess **228** receives a complimentary pro-

jection of a rotatable grate component such as the upper rotatable grate component **11** to which the rotary plough **200** is mounted.

[0189] A bottom of the connector **210**, i.e. the bottom **202**, defines a recessed carrier seat **230** to receive and seat a portion of a plough carrier (e.g. a plough carrier forming part of a rotatable grate component such as the upper rotatable grate component **11** to which the rotary plough **200** is mounted). As can easily be seen in FIG. 5, the recessed carrier seat **230** is defined along a portion of the periphery of the void **226**, i.e. along a periphery of the connector **210** extending between the opposed elongate faces **302**, **402**. Each of the first rotary plough component **300** and the second rotary plough component **400** defines a portion of the carrier seat **230**. The portions of the carrier seat **230** defined by the first rotary plough component **300** and the second rotary plough component **400** are spaced and are respectively located more or less beneath corresponding portions of the mounting seat **220**.

[0190] The first rotary plough component **300** and the second rotary plough component **400** are both in the form of a cast metal body, typically a specially modified heat resistant iron-chromium-nickel alloy of ASTM A297 Grade HF. The elongate faces **302**, **402** are clad in a specially hardened material such as PRO 100 (trade name) or Lincor 60 (trade name) hardfacing. Also portions of the top **204** and the bottom **202** of the rotary plough **200** are clad in the hardened material. This is illustrated in FIGS. 3 to 23 in which the darker shaded areas are the areas clad in the hardfacing material.

[0191] The upper major surface **308** and the lower major surface **310** of the elongate face **302** share a common periphery or edge **320**, which is linear and which extends from the top **204** towards the bottom **202** in a direction from the first end **304** towards the second end **306**. The elongate face **402** has a similar common periphery or edge **420** between the adjacent and bordering upper major surface **408** and lower major surface **410**.

[0192] The edge or border or shoulder line **320** is in the same vertical plane as the lower major surface **310** and the edge or border or shoulder line **420** is in the same vertical plane as the lower major surface **410**. The edges **320**, **420** are thus also diverging in a direction away from the first ends **304**, **404** towards the second ends **306**, **406**.

[0193] In the embodiment of the rotary plough of the invention illustrated in the drawings, the elongate face **302** and the elongate face **402** are mirror images of each other. The first imaginary vertical plane **206** is thus a mirror plane or plane of symmetry for the opposed elongate faces **302**, **402** so that the opposed elongate faces **302**, **402** are mirrored about the first imaginary vertical plane **206**, but are not parallel to the first imaginary vertical plane **206**.

[0194] The elongate faces **302**, **402** are each defined by a plough portion **322**, **422** respectively of the first rotary plough component **300** and the second rotary plough component **400** respectively. The plough portions **322**, **422** are generally wedge-shaped in plan view as can be clearly seen in FIGS. 11 and 18 of the drawings, thickening from their respective first ends **304**, **404** towards their respective second ends **306**, **406**. Each plough portion **322**, **422** has a rounded toe **324**, **424** respectively curving upwardly from the bottom **202** towards the top **204**.

[0195] As can be clearly seen in FIG. 3 of the drawings, the connector **210** defines a lower terrace or step **232** towards a front of the connector **210**. The terrace or step **232** is defined

by both a portion of the connector **210** defined by the first rotary plough component **300** and a portion of the connector **210** defined by the second rotary plough component **400**. A wall **234** borders the terrace or step **232** on three sides. The joint seat **314** and the joint portion **414** both form part of the terrace or step **232**.

[0196] Referring to FIG. 2 of the drawings, a bottom of a rotatable grate assembly in accordance with the invention, located within a gasification vessel of a fixed bed dry bottom gasifier, is shown. The rotatable grate assembly is indicated by reference numeral **500** whereas a wall or jacket of a gasification chamber of the gasification vessel is indicated by reference numeral **502**. An outer shell of the gasification vessel is not shown, but downcomers are indicated by reference numeral **503**. The rotatable grate assembly **500** includes a rotary component **504** which is configured to rotate about a vertical axis of rotation **506** selectively in either a clockwise direction or a counter-clockwise direction. Three rotary ploughs **200** are mounted to a bottom of the rotary component **504** to rotate together with the rotary component **504** in a horizontal plane about the axis of rotation **506** so that the rotary ploughs **200** describe a circle in use. The circle described by the rotary ploughs **200** in use is concentric with the wall **502**.

[0197] The rotary component **504** is the same as the upper rotatable grate component **11** shown in FIG. 1 of the drawings, and the wall **502** is the same as the wall **18** of the gasification vessel **100** shown in FIG. 1 of the drawings. The axis of rotation **506** thus coincides with the axis of rotation **21**. Importantly however, the rotary component **504** illustrates the upper rotatable grate component **11** fitted with rotary ploughs **200** and not another type of rotary plough such as the short straight type or the Sasol® Banana Plough™. As illustrated in FIG. 2 of the drawings, the three rotary ploughs **200** are mounted to the bottom of the rotary component **504** by means of their connectors **210** and the mounting apertures **212**, **214** and **216** defined in the connectors **210**. Each rotary plough **200** is mounted such that the first imaginary vertical plane **206** of the rotary plough **200** coincides with a radius **508** of the circle described by the rotary ploughs **200** during rotation of the rotary component **504** about the axis of rotation **506**. As can also be clearly seen from FIG. 2 of the drawings, the first ends **304**, **404** of the opposed elongate faces **302**, **402** of each rotary plough **200** are closer to the axis of rotation **506** than the second ends **306**, **406**, and are also closer to each other than the second ends **306**, **406** are to each other. In bottom plan view, as shown in FIG. 2 of the drawings, each rotary plough **200** is thus mounted to the rotary component **504** to extend radially away from the axis of rotation **506**, with the second ends **306**, **406** being distal from the axis of rotation **506** and with the rotary plough **200** widening in a radial direction away from the axis of rotation **506**.

[0198] The rotary component **504** is in the form of a circular disc with the rotary ploughs being mounted adjacent a radially outward periphery of the rotary component **504**.

[0199] With reference to FIG. 24 of the drawings, the cast rotary component **504** defines or includes a plurality of peripherally-spaced downwardly projecting shoes **510**. Each shoe **510** defines three apertures and a V-shaped recess or notch **518**.

[0200] The rotary component **504** includes a plurality of integrally formed plough carriers **516** on a bottom thereof (see FIG. 2). The plough carriers **516** are part of the casting of

the rotary component 504. A plough carrier 516 is associated with each mounted rotary plough 200.

[0201] The rotary plough 200 is mounted to the rotary component 504 in a disassembled state. In order to mount a rotary plough 200 to the rotary component 504, the first rotary plough component 300 is positioned such that the shoe 510 is located in or on the mounting seat 220 defined by the first rotary plough component 300 and pins are used to secure the first rotary plough component 300 to the rotary component 504. The plough carrier 516 fits underneath the carrier seat 230 defined by the first rotary plough component 300 so that the carrier seat 230 and the carrier seat 220 are sandwiched between the plough carrier 516 and the shoe 510. Two smaller pins 514 are then inserted through two of the apertures in the shoe 510 and through the mounting apertures 212 and 214 and tack-welded at their heads to the plough carrier 516. The second rotary plough component 400 is then fitted to the rotary component 504 by positioning a portion of the shoe 510 onto or into the portion of the mounting seat 220 defined by the second rotary plough component 400, whereafter a larger pin 514 is inserted through the third aperture in the shoe 510 and through the mounting aperture 216. A head of the larger pin is then also tack-welded to the plough carrier 516. The first rotary plough component 300 and the second rotary plough component 400 are then joined together by means of the pin 218, joint aperture 312 and joint aperture 412. Again, a head of the pin 218 is then tack-welded to the first rotary plough component 300.

[0202] As indicated hereinbefore, each shoe 510 defines a V-shaped recess or notch 518. The V-shaped projection 224 of the rotary plough 200 is snugly received in the V-shaped recess 518. Similarly, the shoe 510 defines a V-shaped downwardly projecting portion (not visible in the drawings) which is received in the V-shaped formation 228 (see FIG. 4) defined in the periphery of the connector 210, between the first rotary plough component 300 and the second rotary plough component 400. The wall 222 abuts against a radially outward face or edge of the shoe 510.

[0203] The rotary ploughs 200 are equiangularly-spaced, being about 120° apart. In the embodiment shown in FIG. 2 of the drawings, the rotary component 504 also includes dummy ploughs or place holders 520. Each dummy plough 520 is associated with a shoe 510 and a plough carrier 516 and is mounted to the rotary component 504 in similar fashion to which the rotary ploughs 200 are mounted.

[0204] Advantageously, the rotary plough 200 as illustrated are as effective as the rotary plough described in WO 2013/110981 in both a clockwise and a counter-clockwise direction of operation. Typically one of these directions will be a normal or forward direction of operation and the other will be a reverse direction which is for example used to get rid of a blockage or the like. During rotation of the rotary component 504, less compression of particles between two successive rotary ploughs 200 is caused, leading to a reduction in erosion of components of the rotatable grate assembly 500 and the gasification vessel 502. One of the angled upper major surfaces 308 and 408 (depending on the direction of rotation) lifts ash particles vertically upwards to fill void spaces in the ash bed which are caused by variable ash particle sizes. One of the lower major surfaces 310 and 410 (depending on the direction of rotation) induces an inward displacement of the ash particles towards the axis of rotation 506 relative to the normal (i.e. 90°) contact vector, thus ensuring removal of the particles via the ash discharge annulus 19. By lifting and

displacing the ash particles inwardly towards the axis of rotation 506, the major surfaces 308, 310, 408, 410 enable ash particles to have particle-to-particle contact surfaces, thus minimising wear on the rotary plough 200 and on other surfaces, e.g. the shield plates 22 or the gasifier wall 18.

[0205] Ploughs with elongate faces such as the elongate faces 302, 402 have shown that extraction efficiency of the plough is increased over ploughs of the prior art, in both a clockwise and in a counter-clockwise direction of operation, i.e. in both a forward or normal direction of operation and in a reverse direction of operation. As the elongate faces 302, 402 are mirror images of each other the rotary plough 200 can effectively remove ash when rotated in a normal or forward direction of operation or in a reverse direction, without a reduction in the ash extraction efficiency or a change in the erosion characteristics. This extends the working life of the plough 200 greatly and prevents high wear and loss of extraction when operating the rotatable grate assembly 500 in a reverse mode.

[0206] Advantageously, the rotary plough 200 is easily retrofitted to an existing rotatable grate assembly without making modifications to the upper rotatable grate component to which the rotary ploughs 200 are to be mounted. The rotary component 504 shown in FIG. 2 of the drawings is an existing rotary component in commercial use in fixed bed dry bottom coal gasifiers operated in South Africa, together with the Sasol® Banana Ploughs™. Advantageously, the rotary plough 200, as illustrated, can be fitted to the rotary component 504 by simply removing the Sasol® Banana Plough™ and mounting the rotary plough 200, without any changes being required to the rotary component 504.

[0207] As the rotary plough 200 is in the form of two components which are separately installed during mounting to a rotary grate component such as an ash grating, assembly is easier as only about half of the significant total weight of the rotary plough 200 has to be positioned and handled at a time.

What is claimed is:

1. A solids handling equipment rotary plough, the rotary plough including
 - a metal body having a bottom and a top, and defining a pair of opposed spaced non-parallel elongate faces extending between the bottom and the top and from a first end to a second end of each opposed elongate face, the first end and the second end being spaced further from each other than the top and the bottom are spaced from each other providing each opposed elongate face with a length greater than a height, the opposed elongate faces being on opposite sides and facing away from a first imaginary vertical plane, each of said opposed elongate faces having at least two elongate major surfaces which are not co-planar, an upper, elongate, non-vertical, major surface being angled towards the first imaginary vertical plane to slope upwardly towards said first imaginary vertical plane at an angle of at least 1° to the vertical and a lower, elongate, vertical, major surface which is angled in a horizontal plane at an angle of at least 2° relative to the lower, elongate, vertical, major surface of the other of the opposed elongate faces so that the first ends of the opposed elongate faces are closer to each other than the second ends of the opposed elongate faces are to each other rendering the opposed elongate faces diverging in a direction from the first ends towards the second ends, the first end of each elongate face being on a common side of a second imaginary vertical plane which is per-

pendicular to the first imaginary vertical plane and which is thus located between the first end and the second end of each elongate face, the opposed spaced non-parallel elongate faces being joined by a connector defining mounting means to mount the rotary plough to a rotatable grate component, said mounting means being located between said opposed non-parallel elongate faces.

2. The solids handling equipment rotary plough as claimed in claim 1, in which the metal body includes or is in the form of at least two separable parts or components, a first part or component defining one of the non-parallel elongate faces and a second part or component defining the other of the non-parallel elongate faces, and with each of the first and second parts or components defining at least a portion of the connector.

3. The solids handling equipment rotary plough as claimed in claim 2, which includes joining means to join the first and second parts or components of the metal body together.

4. The solids handling equipment rotary plough as claimed in claim 2, in which the connector portion of one of the first and second parts or components defines a joint seat to receive and seat a joint portion of the connector portion of the other of the second and first parts or components, the joint seat and the joint portion being configured such that they lock the first part or component and the second part or component together, preventing relative rotation between the first part or component and the second part or component about a fastener joining together the first part or component and the second part or component.

5. The solids handling equipment rotary plough as claimed in claim 1, in which the mounting means includes or is in the form of at least one mounting aperture extending through the connector between the top and the bottom of the metal body.

6. The solids handling equipment rotary plough as claimed in claim 5, in which the mounting means includes or is in the form of at least two spaced mounting apertures, the mounting apertures being positioned and spaced to fall on an arc of a single segment of an imaginary circle, where the imaginary circle has a diameter of between 2000 mm and 4000 mm, or between 4000 mm and 5000 mm.

7. The solids handling equipment rotary plough as claimed in claim 1, in which the connector defines a projection that projects towards said first ends of the elongate faces so that, in use, said projection can be received in a recess or notch or serration or gouge in a periphery of a rotatable grate component to which the solids handling equipment rotary plough is mounted.

8. A solids handling equipment rotary plough part or component, the rotary plough part or component including

a metal body having a bottom and a top, and defining an elongate face extending between the bottom and the top and from a first end to a second end of the elongate face; and

a connector extending away from said elongate face to connect and join the plough part or component to another plough part or component which also has an elongate face to provide a rotary plough with opposed elongate faces that face away from each other,

the first end and the second end of said elongate face being spaced further from each other than the top and the bottom are spaced from each other providing the elongate face with a length greater than a height, the elongate face having at least two elongate major surfaces which

are not co-planar, an upper, elongate, non-vertical, major surface being angled towards the connector at an angle of at least 1° to the vertical and a lower, elongate, vertical, major surface, an angle between the lower, elongate, vertical, major surface and the upper, elongate, non-vertical, major surface thus being greater than 180° ,

the connector being at a substantially right angle to the lower, elongate, vertical, major surface where said angle is taken in a vertical plane perpendicular to the lower, elongate, vertical, major surface and the connector defining mounting means to mount the rotary plough part or component to a rotatable grate component.

9. The solids handling equipment rotary plough part or component as claimed in claim 8, in which the connector includes or defines joining means to connect and join the plough part or component to said another plough part or component which also has an elongate face to provide a solids handling equipment rotary plough with opposed elongate non-parallel faces that face away from each other.

10. The solids handling equipment rotary plough part or component as claimed in claim 8, in which the connector defines a projection that projects towards said first ends of the elongate face so that, in use, said projection can be received in a recess or notch or serration or gouge in a periphery of a rotatable grate component to which the solids handling equipment rotary plough component or part is mounted.

11. The solids handling equipment rotary plough part or component as claimed in claim 8, in which a periphery of the connector on a side of the connector facing towards said first end of said elongate face defines a formation to receive a complementary projection of a rotatable grate component to which the solids handling equipment rotary plough is to be mounted in use.

12. A rotatable grate assembly for a gasifier for gasifying carbonaceous material producing ash, the rotatable grate assembly including

a rotary component configured to rotate about a vertical axis of rotation in at least one direction; and

a plurality of rotary ploughs mounted to the rotary component to rotate together with the rotary component in a horizontal plane about said axis of rotation to describe a circle,

at least one of the rotary ploughs including

a metal body having a bottom and a top, and defining a pair of opposed spaced non-parallel elongate faces extending between the bottom and the top and from a first end to a second end of each opposed elongate face, the first end and the second end being spaced further from each other than the top and the bottom are spaced from each other providing each opposed elongate face with a length greater than a height, the opposed elongate faces being on opposite sides and facing away from a first imaginary vertical plane, each of said opposed elongate faces having at least two elongate major surfaces which are not co-planar, an upper, elongate, non-vertical, major surface being angled towards the first imaginary vertical plane to slope upwardly towards said first imaginary vertical plane at an angle of at least 1° to the vertical and a lower, elongate, vertical, major surface which is angled in a horizontal plane at an angle of at least 2° relative to the lower, elongate, vertical, major surface of the other of the opposed elongate faces so that the first ends of the opposed elongate faces are closer to each other than the second ends of the opposed elongate faces are to each other, the first end of each elongate face being on a common side of a second imaginary

vertical plane which is perpendicular to the first imaginary vertical plane and which is thus located between the first end and the second end of each elongate face, the opposed spaced non-parallel elongate faces being joined by a connector defining mounting means mounting the rotary plough to said rotary component, said mounting means being located between said opposed non-parallel elongate faces.

13. The rotatable grate assembly as claimed in claim **12**, in which the first imaginary vertical plane coincides with a radius of said circle described by the rotary ploughs mounted to the rotary component.

14. The rotatable grate assembly as claimed in claim **12**, in which said first ends of the opposed elongate faces are closer to the axis of rotation of the rotary component than said second ends, and closer to each other than the second ends are to each other so that, with said at least one rotary plough being mounted to the rotary component to extend radially away from the axis of rotation, the rotary plough is in plan view widening in a radial direction away from the axis of rotation.

15. A gasifier for gasifying carbonaceous material, the gasifier including a rotatable grate assembly as claimed in claim **12**, the rotatable grate assembly being mounted within a gasification chamber defined by a gasification vessel.

16. Use of the gasifier as claimed in claim **15** to gasify coal, waste or biomass, or a combination of two or more of coal, waste and biomass.

17. The use as claimed in claim **16**, in which the gasifier is used to gasify coal at a pressure of between 5 bar(g) and 100 bar(g) and at a temperature of between 400° C. and 1600° C.

* * * * *