

A. T. POPE.
HYDRAULIC TUBE EXPANDING AND COMPRESSING MACHINE.

APPLICATION FILED MAR. 19, 1904.

2 SHEETS—SHEET 1.

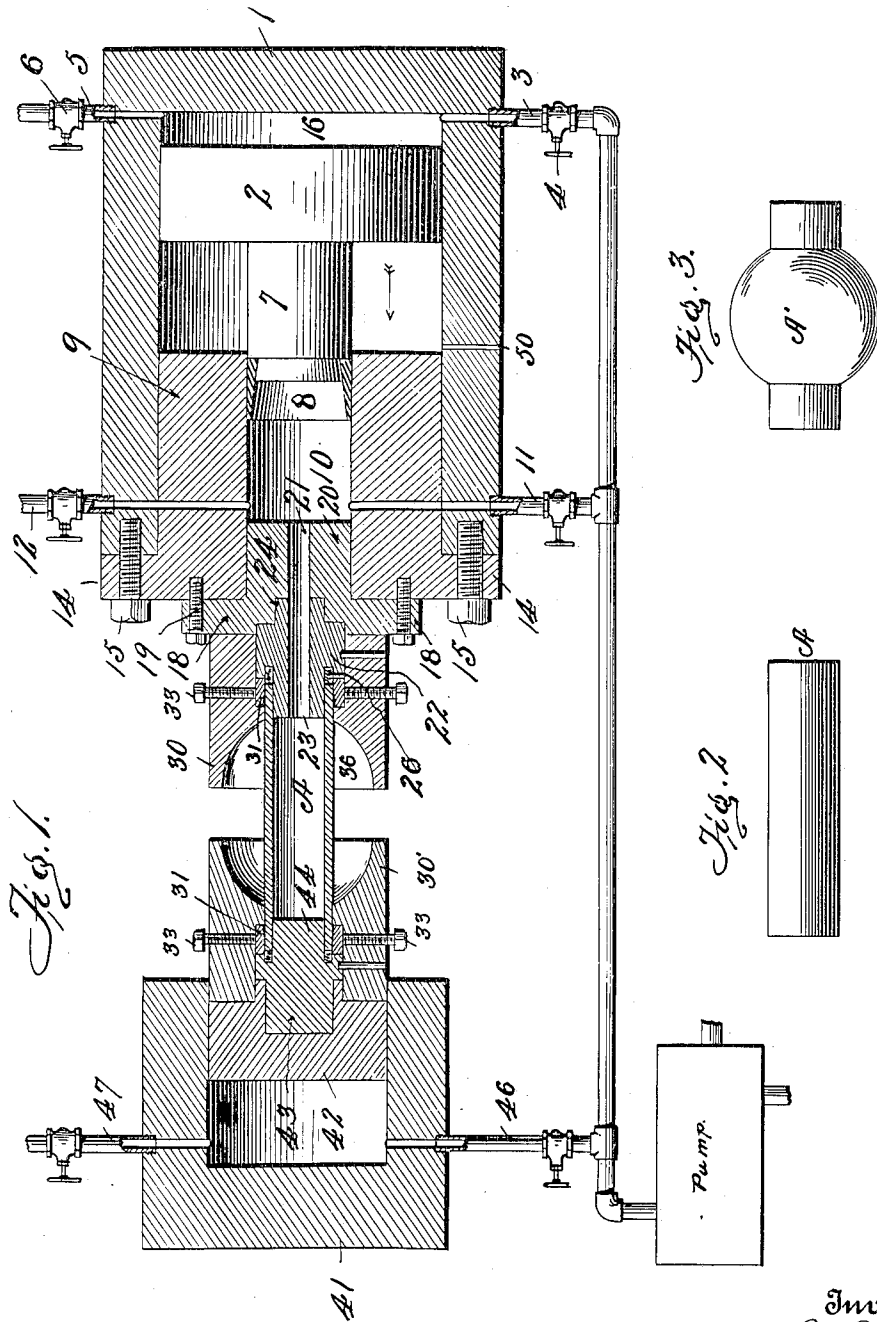

Fig. 1.

Fig. 3.

Fig. 2.

Witnesses
Chas. H. Davis.
Wm. E. Brown.

Inventor
A. T. Pope
By *W. A. Bartlett*
Attorney.

No. 788,119.

PATENTED APR. 25, 1905.

A. T. POPE.

HYDRAULIC TUBE EXPANDING AND COMPRESSING MACHINE.

APPLICATION FILED MAR. 19, 1904.

2 SHEETS—SHEET 2.

Fig. 6.

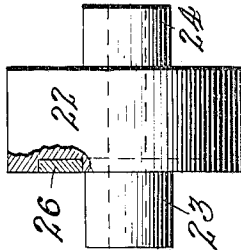

Fig. 5.

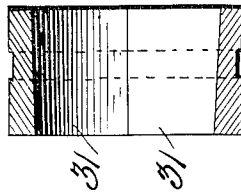
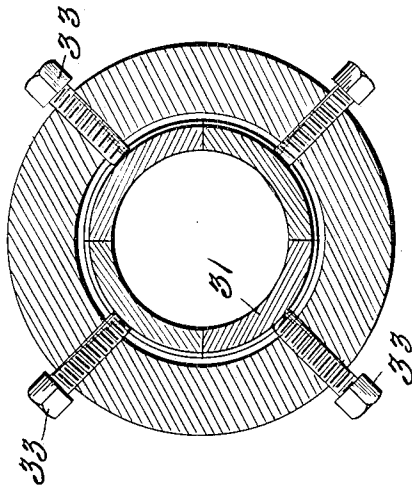

Fig. 4.



Witnesses

Chas. K. Davis.
W. E. Brown

Inventor

A. T. Pope

by

W. A. Bartlett

Attorney

UNITED STATES PATENT OFFICE.

ALFRED THRUSTON POPE, OF LOUISVILLE, KENTUCKY, ASSIGNOR OF TWO-THIRDS TO CURRAN POPE AND FREDERICK E. HEINIG, OF LOUISVILLE, KENTUCKY.

HYDRAULIC TUBE EXPANDING AND COMPRESSING MACHINE.

SPECIFICATION forming part of Letters Patent No. 788,119, dated April 25, 1905.

Application filed March 18, 1904. Serial No. 199,049.

To all whom it may concern:

Be it known that I, ALFRED THRUSTON POPE, a citizen of the United States, residing at Louisville, in the county of Jefferson and State of Kentucky, have invented certain new and useful Improvements in Hydraulic Tube Expanding and Compressing Machines, of which the following is a specification.

This invention relates to hydraulic machines for forming expanded sections on tubes and for compressing said tubes longitudinally.

The object of the invention is to produce a machine in which a short tube-section may be expanded to the form of a sphere or the like in its central or interior portion and the length of the tube contracted simultaneously, so that the thickness of the wall of the expanded portion may substantially equal that of the wall of the non-expanded portion; also, to provide attachments for such a machine by means of which a tube may be readily entered and removed therefrom.

Figure 1 is a longitudinal section of a machine embodying the principles of my invention. Fig. 2 is a side elevation of a tube before expansion. Fig. 3 is a side elevation of a tube after expansion into globular form. Fig. 4 is a cross-section of one of the tube-holders on the line of the holding-screws. Fig. 5 is a side elevation of two of the reinforcing ring or bushing sections. Fig. 6 is a side elevation of one of the plugs which enter the end of the tube, partly broken away.

It is considered unnecessary to describe the bench or frame of the machine, as the same may be of any suitable construction.

The numeral 1 indicates a hydraulic cylinder which contains a piston 2. The cylinder may receive water or other fluid through pipe 3, controlled by cock 4 or in any other usual manner. Outflow from the cylinder for air or water may be by pipe 5, having controlling-cock 6.

The piston 2 has a plunger 7, with a cup or packing 8 at its front end. The front end of the plunger 7 neatly fits a cylindrical opening or chamber 10 in the reinforce 9 in the front part of the cylinder. The opening or cham-

ber 10 in reinforce 9 has a water-supply tube 11 and an exhaust 12, both controlled by suitable valves or cocks. The reinforce 9 has a flange 14, which extends in front of the cylinder 1 and is attached thereto by screws 15 or otherwise. When fluid is pumped into the chamber 16 of the cylinder, the piston 2 is driven forward or in the direction of the arrow. When fluid is pumped into chamber 10, if the outlet therefrom be closed and piston 2 be free to move backward such movement will take place. A vent 50 allows for air escape in front of piston 2.

A face-plate 18 is secured to reinforce 9, as by screws 19. This face-plate has a projection 20, which enters chamber 10. A passage 21 through the face-plate and projection provides access for fluid to the tube to be expanded, (indicated at A, Figs. 1 and 2.) A plug 22 has a central passage, which is a continuation of passage 21, and has a front cylindrical core 23, which enters the tube A. The rear end 24 of plug 22 enters a recess in the face-plate 18. All the surfaces are neatly fitted or made with ground joints to prevent leakage. In the face of plug 22 and surrounding core 23 there is a packing-ring 26, of lead, leather, copper, or other material, which will form a close packing for the end of tube A. The core 23 neatly fits the end of the tube which is to be expanded.

A forming-shell 30 extends in front of plug 22 and is chambered at its rear to a size to receive the ring-sections 31. These ring-sections are internally of the size of the tube A, which is to be expanded. Externally the ring-sections are held in their chamber in the shell by screws 33. When the screws are set up snug, the ring-sections 31 are close around the outside of the tube. After the tube is compressed these ring-sections may be slightly loosened, so that the tube will draw easily. The interior of the ring-sections is preferably slightly tapered to permit the easy withdrawal of the tube. The chamber 36 of the forming-shell 30 is in the form of a semi-sphere or of other form to which the central portion of tube A is to be expanded. The

forming-shell is of strong metal, as are all the parts of the machine illustrated, except as otherwise stated.

At the opposite end of the machine from the cylinder 1 there is another hydraulic cylinder 41. This cylinder has a piston 42. The front or working face of cylinder 41 is in the opposite direction from that of cylinder 1—that is, both cylinders face toward their work, which is to operate on tube A. The front of piston 42 bears a plug 43, similar to the plug 22, except that it has no central opening. The core 44 at the front of this plug is like the core 23, heretofore described, and a split ring 31 surrounds this core at such a distance as to permit the insertion of tube A between the ring and core. The split ring is held up by screws 33, as in the former case. The forming-shell 30' is substantially a duplicate of shell 30. Cylinder 41 receives its supply of fluid through pipe 46 and has an exhaust at 47, or any other usual connections for a hydraulic press may be employed.

It is thought it will be understood from the foregoing that the essential parts of the machine are two hydraulic cylinders facing each other and forming shells and means for expanding a tube between the two. In some cases the work may be done with one cylinder; but I prefer two as being more certain and less complex in construction.

Assuming the construction of machine substantially as described, the operation is as follows: The piston 42 is retired far enough to permit the insertion of a tube-section A, when the piston 42 is moved forward to the position shown in Fig. 1. The pressure on piston 42 should be sufficient to crowd the ends of tube A tightly against the packing 26 in the plugs at the ends of the tube. If not already closed, the sectional rings 31 are now closed firmly about the ends of tube A. Thus the tube is held at its ends on the cores 23 and 44 and is surrounded by the cylindrical bore of the shells 30 30' and the divided rings 31. The shells 30 30' are just far enough apart to provide for the endwise compression of tube A while the expansion is taking place, as will be explained. Fluid being now introduced into chamber 10 will enter tube A through the passage 21. If piston 2 be not already back, the pressure in chamber 10 will force it back, provided the escape be open. When the tube A and chamber 10 are filled with fluid, the outlets from chamber 10 will be closed. Then by applying pressure on piston 2 the fluid in chamber 10 will be forced with great pressure by the advance of piston 2 and plunger 7 into the pipe A, from which there is no escape. Now if fluid be admitted behind piston 42 the shell 30' moves toward the shell 30. The metal of tube A (which may be lead, copper, brass, soft iron, or other untempered metal) will flow on itself in expanding, and the tube will assume the shape

of the chambers in the shells 30 30' at the same time that it is shortened in length. Should the tube not have expanded to fill the shells by the time they have closed together, pressure may be increased by the movement of piston 2. After the ends of shells 30 30' are closed against each other and held by the hydraulic pressure a pressure from piston 2 will drive the fluid of chamber 10 into the tube and insure that the globular portion A' of the tube shall exactly fit the chamber inclosed by those shells. The length and thickness of tube A at the beginning of the operation should be such that metal is supplied to form the globular part A' of sufficient thickness. If properly proportioned, the metal of the tube can be made to flow upon itself sufficiently to make the globular portion A' about as thick as the end sections of the tube. To withdraw the completed article A', the piston 42 is set back, and if the ends of the tube are too firmly clamped by the divided ring 31 the sections of this ring are loosened by drawing back screws 33.

The tubes with globular sections are used for couplings, ball-joints, &c. It is evident that other forms than spheres may be produced, according to the internal shape of the chamber in shells 30 30'.

What I claim is—

1. In a hydraulic tube expander and press, a hydraulic cylinder having a piston therein and a plunger on said piston, a reinforce in said cylinder having a chamber into which said plunger fits, a water-supply tube leading to said chamber, a water-supply tube leading into the cylinder behind the piston, a forming-shell attached to the cylinder and having a passage thereto from the said plunger-chamber, and means for supporting a tube in the forming-shell.

2. In a hydraulic tube expander and press, the combination of a hydraulic cylinder and plunger, a tube-bearing core in front of said plunger and having a passage for fluid from the cylinder, means for closing the opposite end of the tube, and separable shells surrounding the intermediate part of the tube, one of said shells being fixed to the cylinder.

3. The combination of a hydraulic cylinder and piston, a tube-holding core through which fluid may be forced by said piston, means for closing the other end of said tube, a separable shell surrounding the intermediate part of the tube, and means for compressing the tube lengthwise while expanding its body into the shell by fluid-pressure.

4. In a hydraulic tube expanding and compressing machine, a hydraulic cylinder, a shell attached to said cylinder, means for forcing a liquid into said shell, a second cylinder facing the first, a piston within this second cylinder, and a second shell attached to the said piston in position to close against the first-mentioned shell, all combined.

5 5. In a hydraulic tube expanding and compressing machine, the combination of a face-plate; a plug entering a recess in said face-plate and having a projecting cylindrical core, a forming-shell into which said core extends, ring-sections in said chamber outside the core, and means for expanding or contracting the ring-sections.

10 6. The combination with the forming-shell of a hydraulic tube-press, of a central core, a divided ring surrounding the core at a distance sufficient to admit the tube, and means on the shell for holding or releasing the ring-sections.

15 7. The combination with a hydraulic cylinder having a piston and plunger therein, of a reinforce attached to the cylinder and having a central chamber into which said plunger closes, a face-plate secured to said reinforce
20 and having a central passage, a plug remov-

ably attached to said face-plate and having a continuation of said central passage, and a former-shell surrounding said plug and resting against the face-plate.

25 8. In a tube compressing and expanding machine, the combination of a fixed tube-holding core with a passage therethrough, a divided ring surrounding said core, a shell-section surrounding said ring and provided with set-screws bearing on the ring, means for
30 forcing fluid through the core into the tube, and means for closing the opposite end of the tube and for compressing the same longitudinally.

In testimony whereof I affix my signature in presence of two witnesses.

ALFRED THRUSTON POPE.

Witnesses:

W. A. BARTLETT,
M. E. BROWN.