



(19) **United States**

(12) **Patent Application Publication**
Hawes et al.

(10) **Pub. No.: US 2014/0283855 A1**

(43) **Pub. Date: Sep. 25, 2014**

(54) **ELECTRONIC SMOKING ARTICLE**

Publication Classification

(71) Applicant: **Altria Client Services Inc.**, Richmond, VA (US)

(51) **Int. Cl.**
A24F 47/00 (2006.01)

(72) Inventors: **Eric Hawes**, Midlothian, VA (US);
Barry Smith, Hopewell, VA (US)

(52) **U.S. Cl.**
CPC *A24F 47/008* (2013.01)
USPC **131/328; 131/329**

(73) Assignee: **Altria Client Services Inc.**, Richmond, VA (US)

(57) **ABSTRACT**

(21) Appl. No.: **14/203,089**

A smoking article such as an electronic cigarette is disclosed, which includes an outer housing extending in a longitudinal direction; a capillary wick for holding liquid material; a micro pump system configured to pump a liquid material contained within a liquid supply reservoir through an outlet of the supply reservoir to the capillary wick; a heating arrangement operable to heat at least a portion of the capillary wick to a temperature sufficient to at least initially volatilize the liquid material held within the capillary wick; a power supply operable to apply voltage to the micro pump gas cell to generate a gas to pump the liquid material from the liquid supply reservoir into the capillary wick; at least one air inlet; and whereby air is mixed with the volatilized material to form an aerosol.

(22) Filed: **Mar. 10, 2014**

Related U.S. Application Data

(60) Provisional application No. 61/804,304, filed on Mar. 22, 2013.

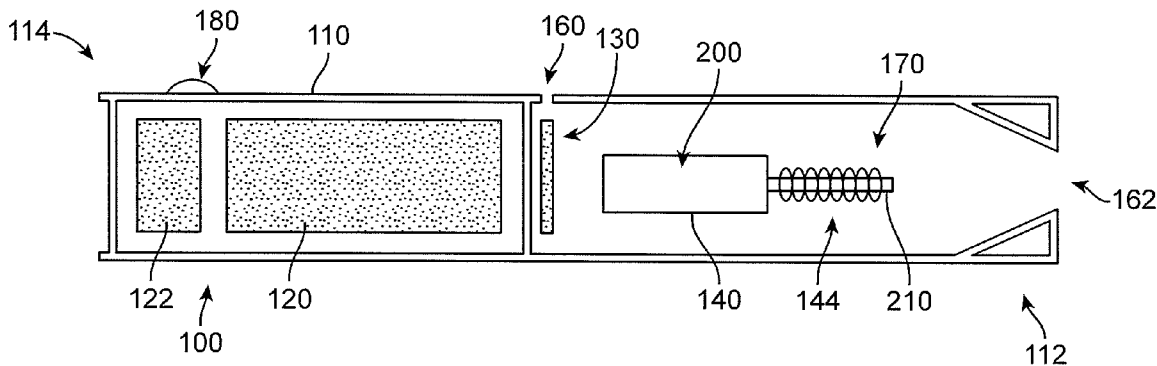

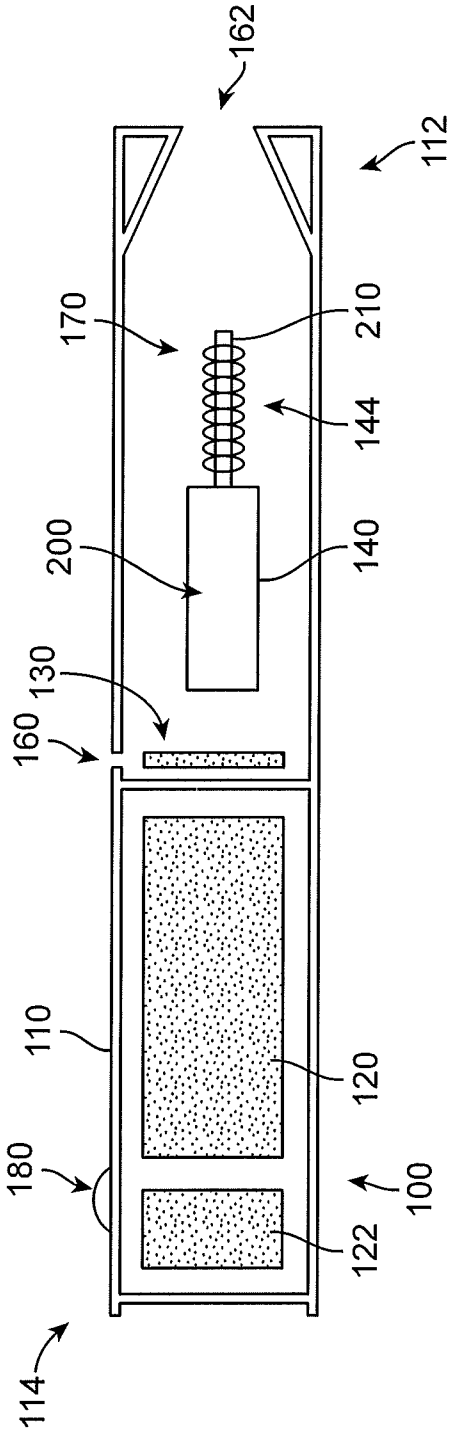

FIG. 1

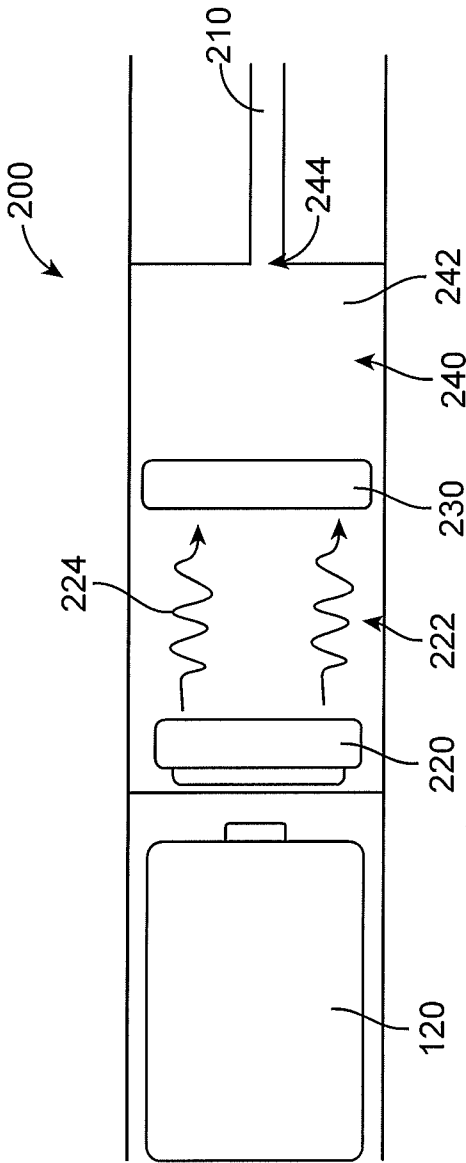

FIG. 2

ELECTRONIC SMOKING ARTICLE

RELATED APPLICATION(S)

[0001] The present application claims priority under 35 U.S.C. 119 to U.S. Provisional Patent Application No. 61/804,304, filed on Mar. 22, 2013, the entire content of which is hereby incorporated by reference.

SUMMARY

[0002] The teachings herein provide embodiments of novel smoking articles such as electronic cigarettes/cigars and aerosol generators. These devices can include a capillary wick designed to deliver liquid material from a liquid reservoir to a heater. The devices can be activated by a consumer drawing on a mouth end of the smoking article to deliver an aerosol to the user. The teachings include application of a gas cell based micro pump as a fluid delivery device in an aerosol based smoke delivery device.

[0003] In accordance with an exemplary embodiment, an electronic smoking article is disclosed, the electronic smoking article comprising: an outer housing extending in a longitudinal direction; a capillary wick for holding liquid material; a micro pump system configured to pump a liquid material contained within a liquid supply reservoir through an outlet of the supply reservoir to the capillary wick; a heating arrangement operable to heat at least a portion of the capillary wick to a temperature sufficient to at least initially volatilize the liquid material held within the capillary wick; a power supply operable to apply voltage to the micro pump gas cell to generate a gas to pump the liquid material from the liquid supply reservoir into the capillary wick; at least one air inlet; and whereby air is mixed with the volatilized material to form an aerosol.

[0004] In accordance with an exemplary embodiment, an electronic smoking article is disclosed, the electronic smoking article comprising: a liquid supply reservoir containing a liquid material; and a micro-pump system comprising: an expandable gas chamber comprising a movable wall of the expandable gas chamber and a wall of the liquid supply reservoir; a micro pump gas cell to generate a gas and to direct the gas to the expandable gas chamber to expand the expandable gas chamber and a capillary wick, wherein expansion of the expandable gas chamber moves the wall to dispense the liquid material from the liquid supply reservoir to the capillary wick.

[0005] In accordance with an exemplary embodiment, a method of producing an aerosol from an electronic smoking article is disclosed, the method comprising: communicating liquid material to a capillary wick using a micro pump system to pump a liquid material from a liquid reservoir to the capillary wick; and communicating electrical power from a power source to a heater operative upon at least a portion of the capillary wick, wherein the capillary wick discharges the liquid communicated to the capillary wick in an at least partially volatilized condition into a mixing chamber.

[0006] In accordance with an exemplary embodiment, a method of improving withdrawal of liquid from a reservoir of an electronic smoking article is disclosed, the method comprising: retaining a liquid in the reservoir with a fibrous mass; and compressing said fibrous mass by communicating an output of a gas-cell micro pump with a flexible wall of said reservoir.

BRIEF DESCRIPTION OF THE DRAWINGS

[0007] The disclosure is explained below with reference to the exemplary embodiments shown in the drawings. In the drawings:

[0008] FIG. 1 is a cross-sectional view of an electronic smoking article in accordance with an exemplary embodiment; and

[0009] FIG. 2 is a cross-sectional view of a portion of an electronic smoking article having a micro pump system and a capillary wick in accordance with an exemplary embodiment.

DETAILED DESCRIPTION

[0010] In accordance with an exemplary embodiment, an electronic smoking article such as an electronic cigarette or electronic cigars, includes a micro pump system, which pushes a column of liquid material through to a capillary wick. In accordance with an exemplary embodiment, the micro pump system comprises a power source in the form of a battery and a micro pump gas cell that generates gas as it discharges to push a plunger or moveable structure, which drives the liquid material out a liquid reservoir at a constant flow rate to the capillary wick.

[0011] FIG. 1 shows an electronic cigarette 100 in accordance with an exemplary embodiment. As shown in FIG. 1, the electronic cigarette 100 includes a housing 110 having a mouth end 112 and a body end 114. In the body end 114, there is provided an electric power supply in the form of battery 120 and electric circuitry in the form of circuitry 122 and a puff detection system 130. The cigarette 100 includes a micro pump system 200 which delivers a liquid material 242 (FIG. 2) from a liquid supply reservoir (or fluid reservoir) 240 to a capillary wick 210 configured to hold a liquid material. In an embodiment, at least a portion of the capillary wick 210 is adjacent (or surrounded by) the heater 144. In accordance with an exemplary embodiment, one end of the capillary wick 210 communicates with the fluid reservoir 240 of the micro pump system 200. Another end portion of the capillary wick 210 is heated by the heater 144. The heater 144 is connected to the electric circuitry 122 via connections (not shown). The housing 110 also includes an air inlet 160, an air outlet 162 at the mouth end 112, and an aerosol forming chamber 170.

[0012] In use, the liquid material 242 is driven by the micro pump system 200 from the fluid reservoir 240 to the capillary wick 210, as shown in FIG. 1. When a user draws on the electronic cigarette 100 at the air outlet 162, ambient air is drawn through air inlet 160. In accordance with an exemplary embodiment, the electronic cigarette 100 can include a puff detection system 130, which senses the puff and activates the micro pump system 200 and the heater 144. The battery 120 supplies a pulse of energy to the heater 144 to heat the end portion of the capillary wick 210 adjacent the heater 144. The liquid material 242 in the capillary wick 210 is vaporized by the heater 144 to create a supersaturated vapor. At the same time, the liquid material 242 being vaporized is replaced by additional liquid material 242 moving along the capillary wick 210 under (responsive to) a pumping action from the micro pump system 200.

[0013] In accordance with an exemplary embodiment, the supersaturated vapor created is mixed with and carried in the air flow from the air inlet 160. In the aerosol forming chamber 170, the vapor condenses to form an inhalable aerosol, which is drawn through the outlet 162 of the article during a puff. As shown in FIG. 1, the circuitry 122 and the puff detection

system 130 are preferably programmable. In accordance with an exemplary embodiment, the circuitry 122 and puff detection system 130 can be used to manage the operation of the electronic cigarette. In accordance with an exemplary embodiment, the micro pump system 200 in conjunction with the physical design of the electronic cigarette 100 can assist with control of the particle size in the aerosol.

[0014] In use, once the capillary wick 210 is heated, the liquid material contained and/or held within a heated portion of the capillary wick 210 is volatilized and mixes with air and forms an aerosol in a mixing chamber 170. The electronic cigarette 100 also includes at least one air inlet 160 operable to deliver air to the mixing chamber 170. The air inlets 160 to the mixing chamber 170 can be arranged downstream of the capillary wick 210 so as to minimize drawing air along the capillary wick and thereby avoid cooling of the capillary wick 210 during heating cycles. In the exemplary embodiment, the at least one air inlet 160 includes one or two air inlets 160. Alternatively, the air inlets 160 can be three, four, or five or more. In accordance with an exemplary embodiment, the size and number of air inlets 160 can also aid in establishing the resistance to draw of the electronic cigarette 100.

[0015] The battery 120 can be a Lithium-ion battery or one of its variants, for example a Lithium-ion polymer battery. Alternatively, the battery 120 may be a Nickel-metal hydride battery, a Nickel cadmium battery, a Lithium-manganese battery, a Lithium-cobalt battery or a fuel cell. In accordance with an exemplary embodiment, the electronic cigarette 100 is usable by a smoker until the energy in the power supply is depleted. Alternatively, the battery 120 may be rechargeable and include circuitry (not shown) allowing the battery to be chargeable by an external charging device. For example, the circuitry, when charged, provides power for a pre-determined number of puffs, after which the circuitry must be re-connected to an external charging device.

[0016] The electronic cigarette 100 also includes control circuitry 122, which can be on a printed circuit board. Once a switch 180 is pressed, the power supply is activated and supplies power to the micro pump system 200 and the heater 144. The control circuitry 122 can also include a heater activation light (not shown) operable to glow when the heater 144 is activated. The control circuitry 122 can also include a timer operable to limit the time for which power is supplied to the micro pump system 200 and the heater 144. The time-period of the electric current supply to the micro pump system 200 and the heater 144 may be pre-set depending on the amount of liquid desired to be vaporized. For example, the control circuitry 122 can be programmable for this purpose.

[0017] In accordance with an exemplary embodiment, when activated, the heater 144 heats a portion of the capillary wick 210 for less than about 10 seconds, more preferably less than about 7 seconds. Thus, the power cycle (or maximum puff length) can range in period from about 1 second to about 10 seconds.

[0018] FIG. 2 is a cross-sectional view of a portion of an electronic cigarette 100 having a micro pump system 200 in accordance with an exemplary embodiment. As shown in FIG. 2, the micro pump system 200 can include a micro pump gas cell 220, a plunger 230, a liquid supply reservoir 240, and a capillary wick 210. In accordance with an exemplary embodiment, the micro pump system 200 is configured to pump a liquid material 242 from a liquid supply reservoir 240 through an outlet 244 to a capillary wick 210. In an embodi-

ment, the capillary wick 210 extends into the liquid supply reservoir through the outlet 244.

[0019] In accordance with an exemplary embodiment, a power supply in the form of a battery 120 is operable to apply voltage across to a heater 144 operable to heat the capillary wick 210 to a temperature sufficient to at least initially volatilize liquid material 242 contained within the capillary wick 210. The power supply also is operable to apply voltage to the micro pump gas cell 220 to generate a gas 224. The pressure of the generated gas 224 moves the plunger 230 along a linear path within the micro pump system 200 to drive or pump the liquid material 242 out of the liquid supply reservoir 240 into the capillary wick 210.

[0020] As shown in FIG. 2, the micro pump system 200 is configured to pump a liquid material 242 from a liquid supply reservoir 240 through an outlet 244 to the capillary wick 210. In accordance with an exemplary embodiment, the liquid supply reservoir 240 comprises a liquid material 242, which is volatilized when heated and forms an aerosol.

[0021] In accordance with an exemplary embodiment, a power supply in the form of a battery 120 is operable to apply voltage across to a heater 144 operable to heat the capillary wick 210 to a temperature sufficient to at least initially volatilize the liquid material 242 contained within the capillary wick 210. The battery 120 can also be operable to apply voltage to the micro pump gas cell 220 to generate a gas 224. The generated gas 224 moves the plunger 230 along a forward direction in a linear path within the micro pump system 200 to drive the liquid material 242 out of the liquid supply reservoir 240.

[0022] In lieu or in addition to the plunger 230, the reservoir 240 may include a flexible wall or bladder in which case the output of the micro-pump gas cell 220 would compress the flexible wall or bladder to pump fluid from the reservoir.

[0023] In accordance with an exemplary embodiment, the micro pump gas cell 220 forms a first wall of an expandable gas chamber 222 and the moveable plunger 230 forms a second wall of the expandable gas chamber 222. The plunger 230 also forms a moveable wall of the fluid reservoir 240. In use, the micro pump gas cell generates a gas 224 on demand and directs the gas 224 into the expandable gas chamber 222 to expand the expandable gas chamber 222, wherein expansion of the expandable gas chamber 222 moves the plunger 230 in a forward direction along a linear path to reduce a volume of the fluid reservoir 240, which dispenses or pushes the liquid material 242 from the fluid reservoir 240 to the capillary wick 210.

[0024] Simultaneously, to delivering liquid material 242 to the capillary wick 210, the power supply 120 is activated and the capillary wick 210 is heated to form a heated section wherein the liquid material 242 is volatilized.

[0025] In accordance with an exemplary embodiment, the capillary wick 210 can be made from a variety of filamentary porous or capillary materials and preferably has a known, pre-defined capillarity. Examples include ceramic- or graphite-based materials in the form of fibers or sintered powders. Wicks of different capillarity can be used to accommodate different liquid physical properties such as density, viscosity, surface tension and vapor pressure. In accordance with an exemplary embodiment, the wick 210 can be designed so that the required amount of liquid material 242 can be delivered to the heater 144.

[0026] In an exemplary embodiment, the electronic cigarette 100 is about the same size as a conventional cigarette. In

some embodiments, the electronic cigarette **100** can be about 80 mm to about 88 mm long and about 7 mm to about 8 mm in diameter. For example, in an exemplary embodiment, the electronic cigarette **100** is about 84 mm long and has a diameter of about 7.8 mm.

[0027] The outer cylindrical housing **110** of the electronic cigarette **100** may be formed of any suitable material or combination of materials. Examples of suitable materials include metals, alloys, plastics or composite materials containing one or more of those materials, or thermoplastics that are suitable for food or pharmaceutical applications, for example polypropylene, polyetheretherketone (PEEK), ceramic, and polyethylene.

[0028] In an exemplary embodiment, the volatilized material formed as described herein can at least partially condense to form an aerosol including particles. The particles contained in the vapor and/or aerosol can range in size from about 0.5 micron to about 4 microns, for example, about 1 micron to about 4 microns. In an exemplary embodiment, the vapor and/or aerosol has a particle size of about 3.3 microns or less. In addition, the particles can be substantially uniform throughout the vapor and/or aerosol.

[0029] In accordance with an exemplary embodiment, the liquid material **242** includes a tobacco-containing material including volatile tobacco flavor compounds which are released from the liquid upon heating. The liquid material **242** may also be a tobacco flavor containing material or a nicotine-containing material. Alternatively, or in addition, the liquid material **242** may include a non-tobacco material. For example, the liquid material **242** may include water, solvents, ethanol, plant extracts and natural or artificial flavors. Preferably, the liquid material further includes an aerosol former. Examples of suitable aerosol formers are glycerine and propylene glycol.

[0030] The heater **144** preferably includes an electrical heating element. The heater **144** preferably includes an electrically resistive material. Suitable electrically resistive materials include but are not limited to: semiconductors such as doped ceramics, electrically "conductive" ceramics (such as, for example, molybdenum disilicide), carbon, graphite, metals, metal alloys and composite materials made of a ceramic material and a metallic material. Such composite materials may include doped or undoped ceramics.

[0031] Examples of suitable doped ceramics include doped silicon carbides. Examples of suitable metals include titanium, zirconium, tantalum and metals from the platinum group. Examples of suitable metal alloys include stainless steel, Constantan, nickel-, cobalt-, chromium-, aluminum-titanium- zirconium-, hafnium-, niobium-, molybdenum-, tantalum-, tungsten-, tin-, gallium-, manganese- and iron-containing alloys, and super-alloys based on nickel, iron, cobalt, stainless steel, Timetal® and iron-manganese-aluminum based alloys. Timetal® is a registered trademark of Titanium Metals Corporation, 1999 Broadway Suite 4110, Denver, Colo. In composite materials, the electrically resistive material may optionally be embedded in, encapsulated or coated with an insulating material or vice-versa, depending on the kinetics of energy transfer and the external physico-chemical properties required.

[0032] The heater **144** may take any suitable form. For example, the heater **144** may take the form of a heating blade. Alternatively, the heater **144** may take the form of a casing or substrate having different electro-conductive portions, or an electrically resistive metallic tube. Alternatively, the heater

144 may be a disk (end) heater or a combination of a disk heater with heating needles or rods. Alternatively, the heater **144** may take the form of a metallic etched foil insulated between two layers of an inert material. In that case, the inert material may include Kapton, all-polyimide or mica foil. Alternatively, the heater **144** may take the form of a sheet of material, which may be rolled around at least a portion of the capillary wick. Alternatively, the heater **144** may take the form of an etched foil folded around at least a portion of the capillary wick. The etched foil may include a metal sheet cut by a laser or by electro-chemical process. The sheet may be made from any suitable material, for example, an iron-aluminum based alloy, an iron-manganese-aluminum base alloy or Timetal®. The sheet may be rectangular in shape, or may have a patterned shape, which may form a coil-like structure when rolled around the capillary wick. Other alternatives include a heating wire or filament, for example, a nickel-chromium (Ni—Cr), platinum, tungsten or alloy wire.

[0033] In an exemplary embodiment, the heater **144** includes a coil of wire at least partially surrounding the capillary wick **210**. In an exemplary embodiment, the heater **144** is a metal wire and/or a metal alloy wire. The heater **144** can be a coil, which can extend fully or partially along the length of capillary wick **210**. The coil may extend fully or partially around the circumference of the capillary wick **210**. In another embodiment, the coil is not in contact with the capillary wick **210**, which allows the heating coil to heat the capillary wick **210** but reduces wastage by not vaporizing more liquid than necessary. This also reduces the amount of liquid which condenses on the inside walls, thereby reducing cleaning requirements.

[0034] The electronic cigarette **100** can include a puff indicator (not shown) for indicating when the heater **144** is activated. In the embodiment in which the electric circuitry includes a puff sensor, the indicator may be activated when the sensor senses air flow indicative of the user taking a puff. In the embodiment in which the electric circuitry includes a manually operable switch, the indicator may be activated by the switch.

[0035] In accordance with an exemplary embodiment, the electronic cigarette **100** having a micro pump system **200** as shown in FIGS. **1** and **2** can be configured to deliver a fluid material **242** at a constant flow rate of about 1 to 5 microliters/second. In accordance with an exemplary embodiment, the micro pump system **200** is configured to displace a total of about 0.5 to 2.0 milliliters of a liquid material **242** during a life of the system with cycle to cycle consistency. For example, the electronic cigarette **100** having a micro pump system **200** can have a life of about 250 cycles, with a cycle duration of up to about 5 seconds and a time between cycles of about 1 second or greater. In accordance with an exemplary embodiment, an outer diameter of the micro pump system **200** can be correlated based on capacity and size, for example, less than 8 mm for an exemplary embodiment. In addition, the micro pump system **200** is preferably isolated from the liquid material **242** and external environment.

[0036] Further details of suitable gas-cell micro-pumps are provided in U.S. Pat. Nos. 8,113,390 and 8,353,426, which are incorporated herein by reference, in their entireties.

[0037] It is also envisioned that the liquid supply reservoir **240** may include a fibrous mass or gauzes(s) to retain the liquid and that the gas-cell pump be operated to move a moveable wall of the reservoir so as to compress the gauze.

Such arrangement could be operated as necessary to assure a more complete and consistent withdrawal of the liquid from the gauze.

[0038] The teachings herein are applicable to all forms of electronic smoking articles, such as electronic cigarettes, cigars, pipes, hookas and others, regardless of their size and shape.

[0039] When the word “about” is used in this specification in connection with a numerical value, it is intended that the associated numerical value include a tolerance of $\pm 10\%$ around the stated numerical value.

[0040] Moreover, when the words “generally” and “substantially” are used in connection with geometric shapes, it is intended that precision of the geometric shape is not required but that latitude for the shape is within the scope of the disclosure. When used with geometric terms, the words “generally” and “substantially” are intended to encompass not only features which meet the strict definitions but also features which fairly approximate the strict definitions.

[0041] It will now be apparent that a new, improved, and nonobvious electronic cigarette has been described in this specification with sufficient particularity as to be understood by one of ordinary skill in the art. Moreover, it will be apparent to those skilled in the art that numerous modifications, variations, substitutions, and equivalents exist for features of the electronic cigarette which do not materially depart from the spirit and scope of the invention. Accordingly, it is expressly intended that all such modifications, variations, substitutions, and equivalents which fall within the spirit and scope of the invention as defined by the appended claims shall be embraced by the appended claims.

What is claimed is:

1. An electronic smoking article, the electronic smoking article comprising:

- an outer housing extending in a longitudinal direction;
- a capillary wick for holding liquid material;
- a micro pump system configured to pump a liquid material contained within a liquid supply reservoir through an outlet of the supply reservoir to the capillary wick;
- a heating arrangement operable to heat at least a portion of the capillary wick to a temperature sufficient to at least initially volatilize the liquid material held within the capillary wick;
- a power supply operable to apply voltage to the micro pump gas cell to generate a gas to pump the liquid material from the liquid supply reservoir into the capillary wick;
- at least one air inlet; and
- whereby air is mixed with the volatilized material to form an aerosol.

2. The electronic smoking article of claim **1**, comprising:

- a mixing chamber downstream of the capillary wick;
- a mouth end having at least one outlet, wherein the mouth end is in fluid communication with the mixing chamber so as to deliver the aerosol to a smoker.

3. The electronic smoking article of claim **1**, wherein the micro pump comprises:

- an expandable gas chamber comprising a plunger forming a wall of the expandable gas chamber and moving along a linear path, and wherein the plunger forms a wall of the liquid supply reservoir; and
- a micro pump gas cell to generate a gas and to direct the gas to the expandable gas chamber to expand the expandable gas chamber, wherein expansion of the expandable gas

chamber moves the plunger in a forward direction along the linear path to reduce a volume of the liquid supply reservoir to dispense the liquid material from the liquid supply reservoir into the capillary wick.

4. The electronic smoking article of claim **3**, comprising:

- a power source connected to the micro pump gas cell; and
- a switch coupled to the power source, the switch configured to activate the micro pump gas cell, and wherein the micro pump gas cell is configured to deliver a constant flow rate of liquid material at about 0.5 microliters/second to 2.0 microliters/second.

5. The electronic smoking article of claim **1**, wherein the power source includes a battery.

6. The electronic smoking article of claim **1**, further including control circuitry operable to control supply of power to a heater of the heating arrangement.

7. The electronic smoking article of claim **1**, wherein the at least one air inlet is located downstream of the capillary wick.

8. The electronic smoking article of claim **1**, further including a switch wherein pressure applied to the switch simultaneously activates a heater of the heating arrangement and micro pump system so as to pump liquid material from the liquid supply reservoir into the capillary wick.

9. An electronic smoking article, the electronic smoking article comprising:

- a liquid supply reservoir containing a liquid material; and
- a micro-pump system comprising:
 - an expandable gas chamber comprising a movable wall of the expandable gas chamber and a wall of the liquid supply reservoir;
 - a micro pump gas cell to generate a gas and to direct the gas to the expandable gas chamber to expand the expandable gas chamber, wherein expansion of the expandable gas chamber moves the wall to dispense the liquid material from the liquid supply reservoir; and
 - a capillary wick for holding liquid material in fluid communication with the liquid supply reservoir.

10. The electronic smoking article of claim **9**, further comprising:

- a power source connected to the micro pump gas cell.
- 11.** The electronic smoking article of claim **10**, comprising:
- a switch coupled to the power source, the switch configured to activate the micro pump gas cell, wherein the micro pump gas cell is configured to deliver a constant flow rate of liquid material at about 0.5 microliters/second to 2.0 microliters/second.

12. A method of producing an aerosol from an electronic smoking article, the method comprising:

- communicating liquid material to a capillary wick using a micro pump system to pump a liquid material from a liquid supply reservoir to the capillary wick; and
- communicating electrical power from a power source to a heater operative upon at least a portion of the capillary wick, wherein the capillary wick discharges the liquid communicated to the capillary wick in an at least partially volatilized condition into a mixing chamber.

13. The method of claim **12**, comprising:

- generating a gas with a micro pump gas cell; and
- communicating the generated gas with the liquid supply reservoir to dispense the liquid material from the liquid supply reservoir to the capillary wick.

14. A method of improving withdrawal of liquid from a reservoir of an electronic smoking article, the method comprising:

retaining a liquid in the reservoir with a fibrous mass; and
compressing said fibrous mass by communicating an output of a gas-cell micro pump with a flexible wall of said reservoir.

* * * * *