

(No Model.)

O. D. McCLELLAN.

GAS BURNER.

No. 319,285.

Patented June 2, 1885.

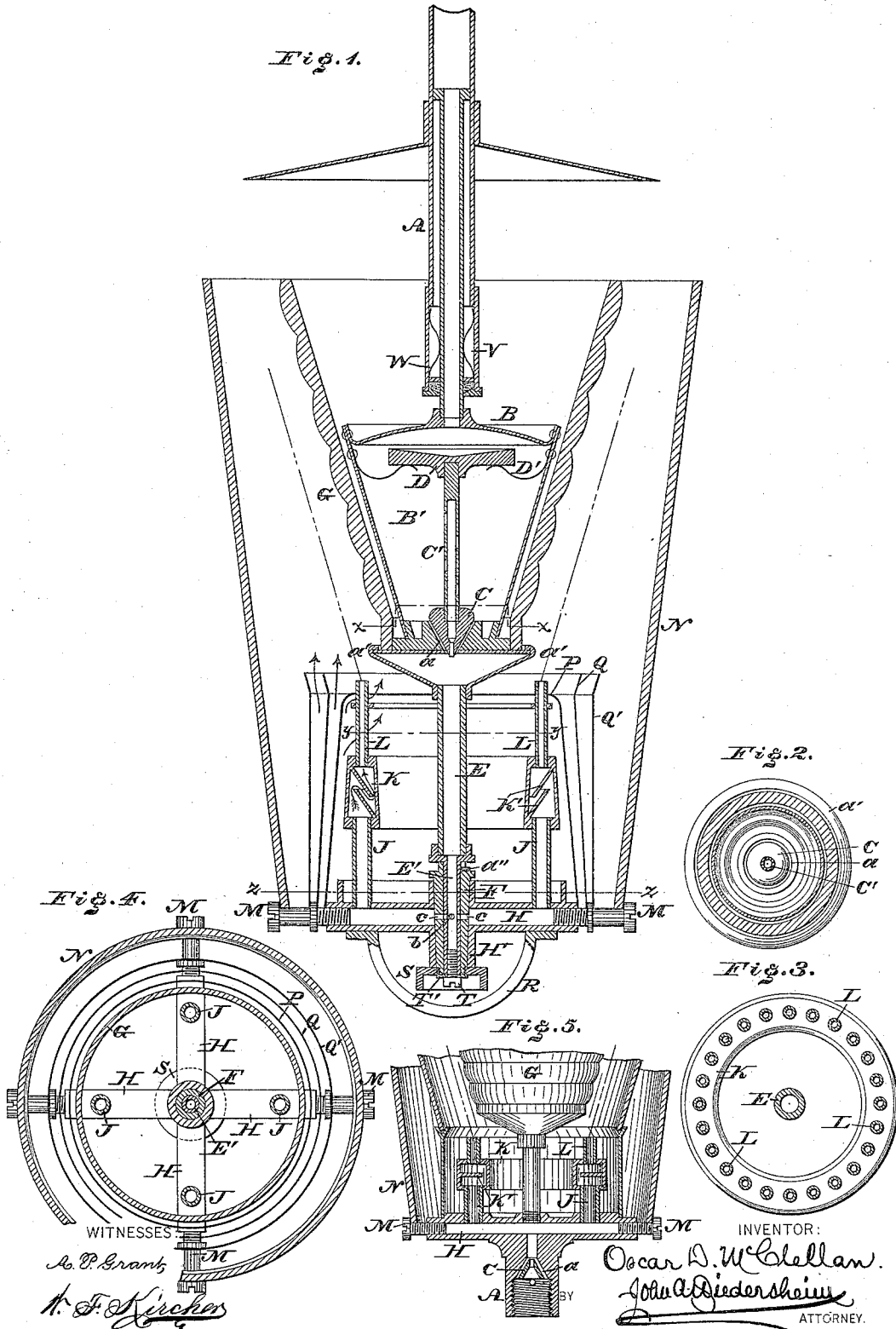

UNITED STATES PATENT OFFICE.

OSCAR D. McCLELLAN, OF PHILADELPHIA, PENNSYLVANIA, ASSIGNOR OF TWO-THIRDS TO BENJAMIN C. BURNS, OF SAME PLACE, AND ADOLPH WASSERMAN, OF ABINGTON, PENNSYLVANIA.

GAS-BURNER.

SPECIFICATION forming part of Letters Patent No. 319,285, dated June 2, 1885.

Application filed July 5, 1884. (No model.)

To all whom it may concern:

Be it known that I, OSCAR D. McCLELLAN, a citizen of the United States, residing in the city and county of Philadelphia, State of Pennsylvania, have invented a new and useful Improvement in Gas-Burners, which improvement is fully set forth in the following specification and accompanying drawings, in which—

Figure 1 is a vertical section of a gas-burner embodying my invention. Fig. 2 is a horizontal section thereof in line *x x*, Fig. 1. Fig. 3 is a horizontal section thereof in line *y y*, Fig. 1. Fig. 4 is a horizontal section in line *z z*, Fig. 1. Fig. 5 is a vertical section of a modification.

Similar letters of reference indicate corresponding parts in the several figures.

My invention consists of improvements in gas-burners, as hereinafter fully set forth.

Referring to the drawings, A represents a gas-pipe which is connected with the supply-pipe located in the ceiling or elsewhere, as well known.

To the lower end of the pipe A is connected a regulator, B, which consists of a closed chamber, B', which has in its base an opening, *a*, the wall whereof constitutes a seat for the valve C, whose stem consists of a perforated tube, C', the upper end whereof is provided with a head, D, against which bear the springs D', which are connected with the chamber B'.

Depending from the chamber B', and in communication therewith, is a pipe, E, whose lower portion, E', has gas-outlets *b*, and is surrounded by a sleeve, F, which has gas-outlets *c*, whereby by the rotation of said sleeve the outlets may register or be closed to each other. The top of the pipe E, or plate at the base of the regulator B, is widened, as at *a'*, to form a support for the reflector G, which surrounds the regulator B and has a corrugated face, for purposes to be hereinafter explained.

H represents tubular arms which radiate from a boss, H', the latter encircling the sleeve F and the former supporting the gas-pipe J, distributor K, and gas jets or burners L, it being noticed that the arms H are in communication with the gas outlets or ports *c*, and the gas-burners L are in communication with said arms H by means of the distributor K and pipe

J, said parts J K L rising one above the other and surrounding the pipe E.

Connected with the ends of the arms H are screws M, for supporting the exterior chimney, N, which is formed of glass or other transparent material, said screws also supporting the air-guides P Q Q', which are located between the chimney N and burners L, and open at top and bottom.

The distributor K consists of an annular chamber within which are secured diaphragms K', which in Fig. 1 are shown diagonally and projecting from opposite sides of said chamber, forming a zigzag passage through the same. In Fig. 5 the distributor has a single diaphragm extending horizontally, said distributor being connected with the arms H, which in this case are supported on a gas-pipe from below.

R represents a handle which is secured to the arms H, for rotating said arms in order that the gas may be turned on or shut off at the ports or outlets *b c*; and S represents a nut which is screwed to the lower end of the sleeve F, the boss H' resting on the upper end of said nut. A bolt, T, is screwed to the bottom of the pipe E, and a washer, T', interposed between the head of said bolt and the lower end of said pipe overlaps the bottom edge of the sleeve F and adjacent portion of the nut S, whereby the sleeve and the arms H, with connected parts, are securely retained in position. By removing the bolt T and washer T' the nut S may be unscrewed, whereby the arms, burners, and other parts connected therewith, the guides P Q Q', and chimney N, may be entirely removed. The sleeve F may be turned to prevent registration of the ports or outlets *b c*, and the bolt T reapplied, thus retaining said sleeve in position and preventing escape of gas. It will be seen that the gas passes through the regulator B into the pipe E, then into the arms H, and thence is directed through the pipes J and distributor K to the burners L, at whose outlet it is ignited, and the light is thus formed. The guide P, extending at its upper end to the burners L below the place of combustion, directs air through the spaces between the burners to the interior of the flame, and the guides Q Q', one or more, supply air to the exterior thereof, so that the

flame assumes a conical form corresponding with the reflector, which, as will be seen, is of reversed order, its broadest part being above, the flame or light produced being brilliant and white, burning with uniformity and without an increased quantity of gas to accomplish the same. The guides Q Q' feed the air to different parts of the exterior of the flame and the glass chimney protects the flame from the impulse of external adverse currents. The burners or jets L and pipes J form circles, and as the distributor is an annulus, the air readily passes between the pipe J, through the central space of the annular distributor, and between the burners L, and so reaches the interior of the flame. The guides P Q Q' are formed of glass, and as the chimney N is of the same material, shadows are prevented from being thrown from the burner. The extent of rotation of the sleeve F is limited by a pin, a'', which projects from the tube E' and a recess on the upper end of the sleeve, the ends of the recess forming shoulders, either of which abuts against said pin relatively to the direction of rotation of the sleeve.

Having thus described my invention, what I claim as new, and desire to secure by Letters Patent, is—

1. A gas-burner, in combination with the

pipe E, the lower portion, E', of which having outlets b, sleeve F, having openings c, the boss H', having arms H, nut S, bolt T, and handle R, attached to said arms, substantially as and for the purpose set forth.

2. The pipe E, in combination with the sleeve F, the boss H', having tubular arms H, the screws M, inserted in ends of arms H, and air-guides P, Q, and Q', the guide P being so placed as to direct the current of air to the inside of the flame, while the currents of air directed by the guides Q and Q' are to the outside thereof, substantially as described.

3. A gas-burner, in combination with the pipe E, having its lower portion, E', provided with a gas-outlet, the sleeve F, surrounding the same, the tubular arms H, the nut S, and bolt T, said arms carrying the burners and made removable from said sleeve F, substantially as and for the purpose set forth.

4. Tubular arms H, provided with screws M, in combination with a chimney, N, and air-guides supported on said screws, substantially as and for the purpose set forth.

OSCAR D. McCLELLAN.

Witnesses:

JOHN A. WIEDERSHEIM,
A. P. GRANT.