

# United States Patent

Sawada

[15] 3,671,894

[45] June 20, 1972

[54] **DEFLECTION YOKES FOR CATHODE RAY TUBES**

[72] Inventor: **Elji Sawada**, Tokyo, Japan  
[73] Assignee: **Denki Onkyo Company, Limited**, Tokyo, Japan  
[22] Filed: **April 15, 1970**  
[21] Appl. No.: **28,627**

[30] **Foreign Application Priority Data**  
April 18, 1969 Japan.....44/35196

[52] U.S. Cl. ....**335/210, 178/7.81**  
[51] Int. Cl. ....**H01J 7/00**  
[58] Field of Search .....178/7.8, 7.81; 335/210, 212, 335/213; 313/75, 76, 77

[56] **References Cited**

UNITED STATES PATENTS		
3,516,038	6/1970	Hisamoto et al.....335/212
2,852,712	9/1958	Fabel.....335/213 X
3,363,206	1/1968	Joseph.....335/210

**FOREIGN PATENTS OR APPLICATIONS**

1,358,834	3/1964	France.....335/210
-----------	--------	--------------------

*Primary Examiner*—George Harris  
*Attorney*—Chittick, Pfund, Birch, Samuels and Gauthier

[57] **ABSTRACT**  
A deflection yoke for use in a cathode ray tube comprises a yoke bobbin, at least two pairs of segments projecting axially from the rear edge of the yoke bobbin and means for clamping the segments about the cathode ray tube to secure thereon the deflection yoke.

**4 Claims, 3 Drawing Figures**

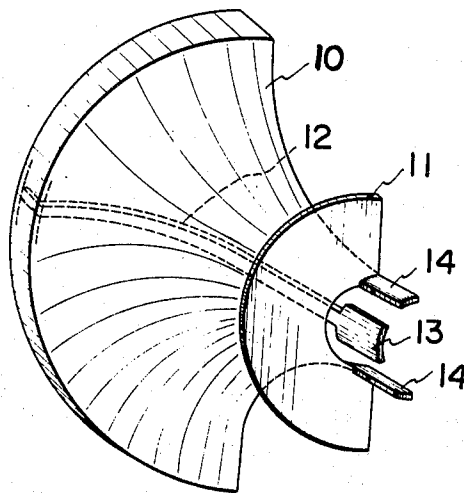

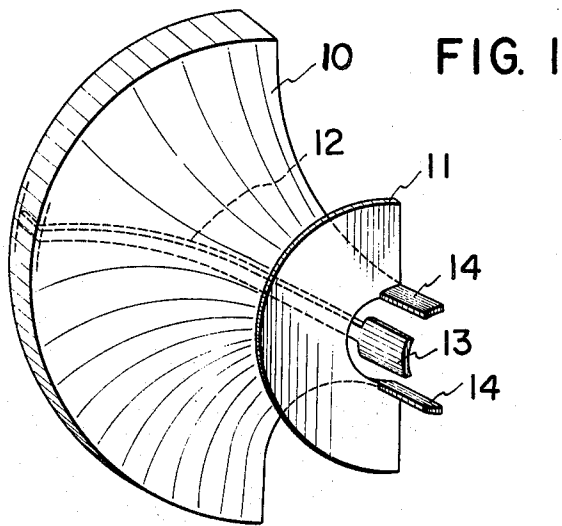

FIG. 2

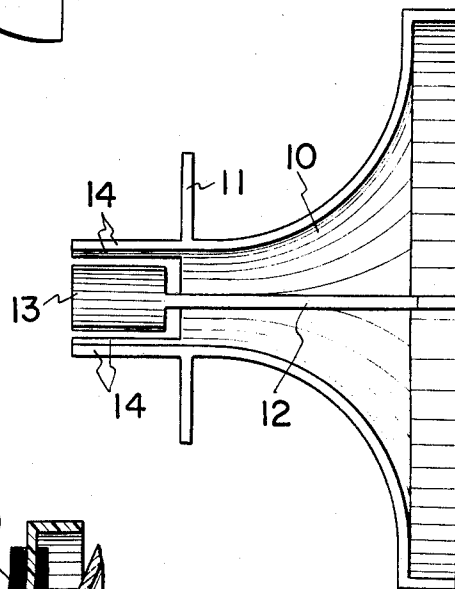
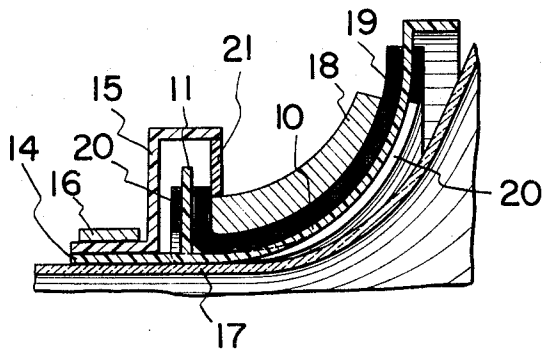

FIG. 3



EIJI SAWADA INVENTOR

BY *Chittick, Pfund, Birch*  
*Samuels & Gauthier*  
ATTORNEY

## DEFLECTION YOKES FOR CATHODE RAY TUBES

## BACKGROUND OF THE INVENTION

This invention relates to improvements of a deflection yoke for cathode ray tubes.

As is well known in the art, in a cathode ray tube for use in color television receivers, for example, it is necessary to mount a deflection yoke on the neck portion of the cathode ray tube such as the yoke can be moved axially and circumferentially around the neck and then secured to a position giving the best color pictures.

Prior means for adjusting the deflection yoke and then securing it at the desired position include

1. Means wherein rings are secured to the flared fore end of the deflection yoke, pawls are provided for respective rings, the outer ends of the pawls are secured to the outer wall of the cathode ray tube by means of a tape having adhesive surfaces on both sides and the rear end of the deflection yoke is clamped against the outer wall of the cathode ray tube.

2. An arrangement wherein the deflection yoke is slidable in a bucket shaped conical cylinder, and

3. An arrangement wherein three supporting frames are assembled and the deflection yoke is disposed and adjusted in the assembly.

However means 1 is not advantageous in that it is necessary to provide pawls at the flared fore end of the deflection yoke and that when securing the deflection yoke after adjustment, the tape utilized for securing pawls tends to be peeled off from the wall of the cathode ray tube. The arrangement 2 is expensive and not suitable for practical use whereas the arrangement 3 is not suitable for the miniaturization of the deflection yoke. In addition, all of these prior means require additional component parts for securing the deflection yoke.

## SUMMARY OF THE INVENTION

It is therefore an object of this invention to provide a novel construction of the deflection yoke for the cathode ray tube which can eliminate these prior disadvantages.

Another object of this invention is to provide a novel deflection yoke which can be readily and positively secured on the neck portion of the cathode ray tube.

According to this invention there is provided a deflection yoke for use in a cathode ray tube comprising a yoke bobbin, at least two pairs of segments projecting axially from the rear edge of the yoke bobbin and means for clamping the segments about the cathode ray tube to secure thereon the deflection yoke. The yoke bobbin is divided into two symmetrical halves each including at least three segments.

## BRIEF DESCRIPTION OF THE DRAWING

The invention can be more fully understood from the following detailed description taken in conjunction with the accompanying drawing in which:

FIG. 1 is a perspective view of one half of the bobbin of a deflection yoke embodying this invention;

FIG. 2 shows a side view of the one half shown in FIG. 1 as viewed from right; and

FIG. 3 is a sectional view showing the manner of mounting the tube.

Referring now to the accompanying drawing, there is shown in FIGS. 1 and 2 one half 10 of the bobbin of a deflection yoke embodying this invention. As shown, the bobbin is flared so that it extends outwardly to a flange at its large end. The bobbin has formed at its rear edge an integral flange 11 in the form of a semicircular disc perpendicular to the axis of the bobbin. Inside the one half of the bobbin 10 is formed an integral axial rib 12 for the purpose of preventing electric discharge between deflection coils, not shown, and to secure the coils to the bobbin.

Usually two such bobbin halves 10 are assembled together to form a yoke bobbin to support a core, a vertical deflection coil and a horizontal deflection coil thus forming a deflection yoke.

According to this invention at least two pairs of projected segments are provided for the rear edge of the yoke bobbin to extend in the axial direction thereof, said projected segments being adapted to be clamped around the neck of a cathode ray tube (not shown) to positively fix in position the deflection yoke.

More particularly, in the embodiment shown in FIGS. 1 and 2, the projection 12 of the bobbin half 10 extends axially beyond the flange 11 to form an integral arcuate segment 13.

Two similar arcuate segments 14 are formed on the inner edge of the flange 11 to extend axially. When two such bobbin halves 10 are assembled together to form a bobbin, two segments 13 opposed each other diametrically. Another pair of combined segments 14 also oppose each other diametrically.

(When two halves are assembled together two adjacent segments 14 are combined into one.) In the illustrated embodiment each pair of segments 13 and 14 is substantially perpendicular to the axis. In other words, when the deflection yoke is mounted on a cathode ray tube segments 13 will assume the horizontal position with respect to the axis, whereas segments 14 the vertical position.

As mentioned above, after assembling the core, vertical deflection coil and horizontal deflection coil on the bobbin, the resulted deflection yoke is fit around the neck portion of the cathode ray tube. Then the deflection yoke is adjusted in the axial and or circumferential direction to obtain the best color picture. Thereafter two pairs of segments 13 and 14 are clamped against the outer wall of the neck to secure the deflection yoke at the adjusted position. Clamping of segments 13 and 14 may be accomplished by clamping them directly by means of a suitable band and then mounting a rear lid of the bobbin or, as shown in FIG. 3, by clamping the segments 13 and 14 are rear led 15 by means of the same band 16. However, it is to be understood that the deflection yoke may be secured more stably when segments 13 and 14 are clamped directly by the band 16. In FIG. 3 numeral 17 designates the bulb of the cathode ray tube, 18 a core, 19 a vertical deflection coil, 20 a horizontal deflection coil and 21 a terminal board.

Pairs of segments 13 and 14 which project from the rear edge of the bobbin and are urged against the outer wall of the neck of the cathode ray tube effectively prevent the deflection yoke from moving vertically and horizontally. More particularly as each pair of the segments 13 and 14 is arranged at substantially right angles to the axis of the tube or bobbin one pair prevents vertical movement of the deflection yoke while the other pair the horizontal movement. In this manner as the deflection yoke is positively secured to the cathode ray tube it is not necessary to use any means to secure the flared front end of the deflection yoke to the outer wall of the cathode ray tube.

Thus, according to this invention by merely providing at least two pairs of segments projecting axially from the rear edge of the yoke bobbin the deflection yoke can be positively secured in position, thus rendering very easy to mount the deflection yoke. In addition, since the construction of the deflection yoke is relatively simple, its cost of manufacturing is low.

It is to be understood that above described embodiment is only one example of this invention and that the configuration and arrangement of the bobbin and segments can be modified variously without departing from the scope of the invention.

What is claimed is:

1. A deflection yoke for a cathode ray tube having a substantially cylindrical neck and an outwardly extending flared portion located forward of said neck, said deflection yoke comprising: a yoke bobbin having

a forward end surrounding and spaced from the flared portion of said cathode ray tube, said forward end tapering inwardly into a substantially cylindrical neck portion at the neck of said cathode ray tube,

an integral solid flange extending radially from the outer surface of said cylindrical neck portion and at least two pairs of opposed integral segments projecting beyond said

3

4

flange as axial extensions of the inner surface of said cylindrical neck portion and located about the neck of said cathode ray tube; and

means for clamping said segments about the neck of said cathode ray tube to secure thereon said deflection yoke.

2. The deflection yoke according to claim 1 wherein said pairs of segments are perpendicular to each other.

3. The deflection yoke according to claim 1 wherein said

yoke bobbin comprises two symmetrically divided halves each having two of said segments diametrically opposed and one additional segment intermediate of said opposed segments in the circumferential direction.

5 4. The deflection yoke of claim 3 and including a flared axial rib on the inner surface of said flared cone with said additional segment projecting on an axial extension of said rib.

\* \* \* \* \*

10

15

20

25

30

35

40

45

50

55

60

65

70

75