

(19) World Intellectual Property Organization  
International Bureau



(43) International Publication Date  
13 March 2008 (13.03.2008)

PCT

(10) International Publication Number  
**WO 2008/030757 A1**

(51) International Patent Classification:  
A61B 5/00 (2006.01) G01N 33/00 (2006.01)  
C12Q 1/00 (2006.01)

(74) Agent: GARRETT, Arthur, S.; Finnegan, Henderson Farabow, Garrett & Dunner, LLP, 901 New York Avenue, NW, Washington, DC 20001-4413 (US).

(21) International Application Number:  
PCT/US2007/077236

(81) Designated States (unless otherwise indicated, for every kind of national protection available): AE, AG, AL, AM, AT, AU, AZ, BA, BB, BG, BH, BR, BW, BY, BZ, CA, CH, CN, CO, CR, CU, CZ, DE, DK, DM, DO, DZ, EC, EE, EG, ES, FI, GB, GD, GE, GH, GM, GT, HN, HR, HU, ID, IL, IN, IS, JP, KE, KG, KM, KN, KP, KR, KZ, LA, LC, LK, LR, LS, LT, LU, LY, MA, MD, ME, MG, MK, MN, MW, MX, MY, MZ, NA, NG, NI, NO, NZ, OM, PG, PH, PL, PT, RO, RS, RU, SC, SD, SE, SG, SK, SL, SM, SV, SY, TJ, TM, TN, TR, TT, TZ, UA, UG, US, UZ, VC, VN, ZA, ZM, ZW.

(22) International Filing Date: 30 August 2007 (30.08.2007)

(25) Filing Language: English

(26) Publication Language: English

(30) Priority Data:  
60/842,032 5 September 2006 (05.09.2006) US

(71) Applicant (for all designated States except US): HOME DIAGNOSTICS, INC. [US/US]; 2400 NW 55th Court, Fort Lauderdale, FL 33309 (US).

(84) Designated States (unless otherwise indicated, for every kind of regional protection available): ARIPO (BW, GH, GM, KE, LS, MW, MZ, NA, SD, SL, SZ, TZ, UG, ZM, ZW), Eurasian (AM, AZ, BY, KG, KZ, MD, RU, TJ, TM), European (AT, BE, BG, CH, CY, CZ, DE, DK, EE, ES, FI, FR, GB, GR, HU, IE, IS, IT, LT, LU, LV, MC, MT, NL, PL, PT, RO, SE, SI, SK, TR), OAPI (BF, BJ, CF, CG, CI, CM, GA, GN, GQ, GW, ML, MR, NE, SN, TD, TG).

(72) Inventors; and

(75) Inventors/Applicants (for US only): NEEL, Gary, T. [US/US]; 1520 BlueJay Circle, Weston, FL 33327 (US). BELL, Douglas, E. [US/US]; 5155 N.W. 84th Road, Coral Springs, FL 33067 (US). SLOMSKI, Dennis [US/US]; 10299 Trianon Place, Wellington, FL 33467 (US). DENG, David, Z. [US/US]; 959 Nandina Drive, Weston, FL 33327 (US).

Published:  
— with international search report

(54) Title: SYSTEM AND METHODS FOR DETERMINING AN ANALYTE CONCENTRATION INCORPORATING A HEMATOCRIT CORRECTION

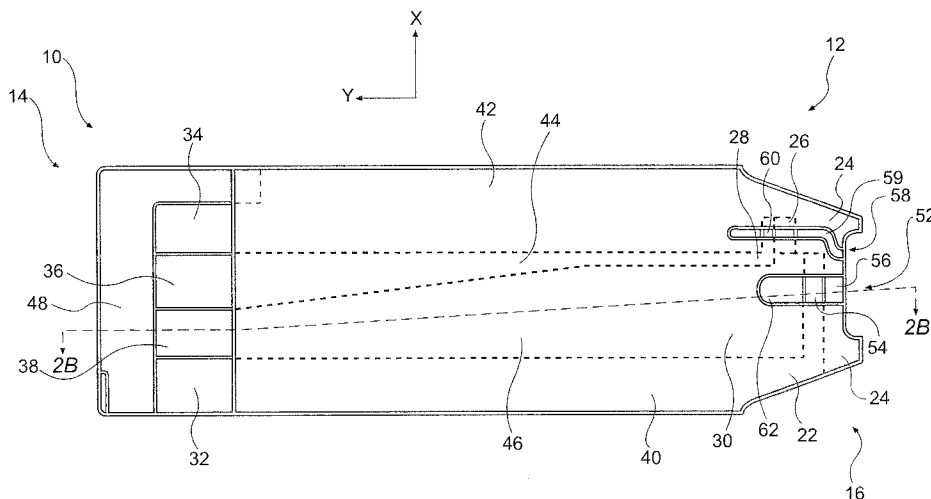

(57) Abstract: Methods and devices for determining the concentration of a constituent in a physiological sample are provided. The blood sample is introduced into a test strip with portions of the blood sample being directed to both a first capillary and a second capillary. The first capillary configured to electrochemically determine a concentration of a first analyte in a blood sample by measuring a signal across a set of electrodes. The second capillary is configured to determine a hematocrit value of the blood sample by measuring a signal across a second set of electrodes.

WO 2008/030757 A1

# SYSTEM AND METHODS FOR DETERMINING AN ANALYTE CONCENTRATION INCORPORATING A HEMATOCRIT CORRECTION

[001] This application claims priority to U.S. Provisional Patent Application No. 60/842,032, filed September 5, 2006, the content of which is incorporated herein by reference.

## DESCRIPTION OF THE INVENTION

### Field of the Invention

[002] The present invention relates to the field of diagnostic testing systems for measuring the concentration of an analyte in a blood sample and, more particularly, to methods for measuring an analyte concentration that incorporates a hematocrit correction.

### Background of the Invention

[003] The present disclosure relates to a biosensor system for measuring an analyte in a bodily fluid, such as blood, wherein the system comprises a unique process and system for correcting inaccuracies in sample concentration measurements. For example, the present disclosure provides methods of correcting analyte concentration measurements of bodily fluids.

[004] Electrochemical sensors have long been used to detect and/or measure the presence of substances in a fluid sample. In the most basic sense, electrochemical sensors comprise a reagent mixture containing at least an electron transfer agent (also referred to as an "electron mediator") and an analyte specific bio-catalytic protein (e.g. a particular enzyme), and one or more electrodes. Such sensors rely on electron transfer between the electron mediator and the electrode surfaces and function by measuring electrochemical redox reactions. When used in an electrochemical biosensor system or device, the electron transfer reactions

are transformed into an electrical signal that correlates to the concentration of the analyte being measured in the fluid sample.

[005] The use of such electrochemical sensors to detect analytes in bodily fluids, such as blood or blood derived products, tears, urine, and saliva, has become important, and in some cases, vital to maintain the health of certain individuals. In the health care field, people such as diabetics, for example, have a need to monitor a particular constituent within their bodily fluids. A number of systems are available that allow people to test a body fluid, such as, blood, urine, or saliva, to conveniently monitor the level of a particular fluid constituent, such as, for example, cholesterol, proteins, and glucose. Patients suffering from diabetes, a disorder of the pancreas where insufficient insulin production prevents the proper digestion and utilization of sugar, have a need to carefully monitor their blood glucose levels on a daily basis. Routine testing and controlling blood glucose for people with diabetes can reduce their risk of serious damage to the eyes, nerves, and kidneys.

[006] A number of systems permit people to conveniently monitor their blood glucose levels, and such systems typically include a test strip where the user applies a blood sample and a meter that "reads" the test strip to determine the glucose level in the blood sample. An exemplary electrochemical biosensor is described in U.S. Patent No. 6,743,635 ('635 patent) which is incorporated by reference herein in its entirety. The '635 patent describes an electrochemical biosensor used to measure glucose level in a blood sample. The electrochemical biosensor system is comprised of a test strip and a meter. The test strip includes a sample chamber, a working electrode, a counter electrode, and fill-detect electrodes. A reagent layer is disposed in the sample chamber. The reagent layer contains an enzyme specific for glucose, such as, glucose oxidase, and a mediator, such as, potassium ferricyanide or ruthenium hexaamine. When a user applies a blood sample to the sample chamber on the test strip, the reagents react with the glucose in the blood sample and the meter applies a voltage to the electrodes to cause redox reactions. The meter measures the resulting current that flows between the working and counter electrodes and calculates the glucose level based on the current measurements.

[007] Biosensors configured to measure a blood constituent may be affected by the presence of certain blood components that may undesirably affect the measurement and lead to inaccuracies in the detected signal. This inaccuracy may result in an inaccurate glucose reading, leaving the patient unaware of a potentially dangerous blood sugar level, for example. As one example, the particular blood hematocrit level (i.e., the percentage of the amount of blood that is occupied by red blood cells) can erroneously affect a resulting analyte concentration measurement.

[008] Variations in a volume of red blood cells within blood can cause variations in glucose readings measured with disposable electrochemical test strips. Typically, a negative bias (i.e., lower calculated analyte concentration) is observed at high hematocrits, while a positive bias (i.e., higher calculated analyte concentration) is observed at low hematocrits. At high hematocrits, for example, the red blood cells may impede the reaction of enzymes and electrochemical mediators, reduce the rate of chemistry dissolution since there less plasma volume to solvate the chemical reactants, and slow diffusion of the mediator. These factors can result in a lower than expected glucose reading as less current is produced during the electrochemical process. Conversely, at low hematocrits, less red blood cells may affect the electrochemical reaction than expected, and a higher measured current can result. In addition, the blood sample resistance is also hematocrit dependent, which can affect voltage and/or current measurements.

[009] Several strategies have been used to reduce or avoid hematocrit based variations on blood glucose readings as described in U.S. Patent Application No. 11/401,458 which is incorporated by reference herein in its entirety. For example, test strips have been designed to incorporate meshes to remove red blood cells from the samples, or have included various compounds or formulations designed to increase the viscosity of red blood cell and attenuate the effect of low hematocrit on concentration determinations. Further, biosensors have been configured to measure hematocrit by measuring optical variations after irradiating the blood sample with light, or measuring hematocrit based on a function of sample chamber fill time. These methods have the disadvantages of increasing the cost

and complexity of test strips and may undesirably increase the time required to determine an accurate glucose measurement.

[010] In addition, alternating current (AC) impedance methods have also been developed to measure electrochemical signals at frequencies independent of a hematocrit effect. Such methods suffer from the increased cost and complexity of advanced meters required for signal filtering and analysis.

[011] An additional prior hematocrit correction scheme is described in U.S. Patent No. 6,475,372. In that method, a two potential pulse sequence is employed to estimate an initial glucose concentration and determine a multiplicative hematocrit correction factor. A hematocrit correction factor is a particular numerical value or equation that is used to correct an initial concentration measurement, and may include determining the product of the initial measurement and the determined hematocrit correction factor. Data processing using this technique, however, is complicated because both a hematocrit correction factor and an estimated glucose concentration must be determined to establish the corrected glucose value. In addition, the time duration of the first step greatly increases the overall test time of the biosensor, which is undesirable from the user's perspective.

[012] Accordingly, novel systems and methods for providing corrected analyte concentration measurements are desired that overcome the drawbacks of current biosensors and improve upon existing electrochemical biosensor technologies so that measurements are more accurate.

### **SUMMARY OF THE INVENTION**

[013] One embodiment is directed to a biosensor having a base layer including a first capillary disposed on the base layer configured to electrochemically determine a concentration of a first analyte in a blood sample, and wherein the first capillary includes a first set of at least one electrode. The biosensor also includes a second capillary disposed on the base layer configured to determine a value correlating to the hematocrit level of the blood sample, and wherein the second capillary includes a second set of at least one electrode.

[014] Another embodiment of the invention is directed to a method for manufacturing a biosensor comprising at least partially forming a plurality of

electrodes on a generally planar base layer. The method also includes forming a first capillary disposed on the base layer, and wherein the first capillary includes a first set of at least one electrode selected from the plurality of at least partially formed electrodes. Further, the method includes forming a second capillary on the base layer, and wherein the second capillary includes a second set of at least one electrode selected from the plurality of at least partially formed electrodes.

[015] Another embodiment of the invention is directed to a reel for manufacturing biosensors comprising a generally planar base layer including a plurality of at least partially formed electrodes. Additionally, the reel includes a first capillary disposed on the base layer, and wherein the first capillary includes a first set of at least one electrode selected from the plurality of at least partially formed electrodes. The reel also includes forming a second capillary on the base layer, and wherein the second capillary includes a second set of at least one electrode selected from the plurality of at least partially formed electrodes.

[016] Another embodiment of the invention is directed to a method of manufacturing a plurality of test strips for a biosensor comprising forming a reel containing a base layer. Moreover, the method includes forming a plurality of electrodes on the base layer, and partially forming a test strip, wherein the test strip includes a first capillary on the base layer including at least one of the plurality of electrodes and the test strip further includes a second capillary on the base layer including at least one of the plurality of electrodes.

[017] Another embodiment of the invention is directed to a test card for quality control analysis of biosensors comprising a base layer, wherein the base layer includes a plurality of electrodes. Further, a plurality of partially formed test strips, wherein each test strip includes a first capillary on the base layer including at least one of the plurality of electrodes and each test strip further includes a second capillary on the base layer including at least one of the plurality of electrodes.

[018] Additional objects and advantages of the invention will be set forth in part in the description which follows, and in part will be obvious from the description, or may be learned by practice of the invention. The objects and advantages of the invention will be realized and attained by means of the elements and combinations particularly pointed out in the appended claims.

[019] It is to be understood that both the foregoing general description and the following detailed description are exemplary and explanatory only and are not restrictive of the invention, as claimed.

[020] The accompanying drawings, which are incorporated in and constitute a part of this specification, illustrate several embodiments of the invention and together with the description, serve to explain the principles of the invention.

### **BRIEF DESCRIPTION OF THE DRAWINGS**

[021] The accompanying drawings, which are incorporated in and constitute a part of this specification, illustrate several embodiments of the invention and together with the description, serve to explain the principles of the invention.

[022] Fig. 1A illustrates test media that can be produced using the methods of the present disclosure.

[023] Fig. 1B illustrates a test meter that can be used with test media produced according to the methods of the present disclosure.

[024] Fig. 1C illustrates a test meter that can be used with test media produced according to the methods of the present disclosure.

[025] Fig. 2A is a top plan view of a test strip according to an exemplary embodiment of the invention.

[026] Fig. 2B is a cross-sectional view of the test strip of Fig. 2A, taken along line 2B-2B.

[027] Fig. 3A shows a configuration of sample chambers on test strip 10 according to the methods of the present disclosure.

[028] Fig. 3B shows a configuration of sample chambers on test strip 10 according to the methods of the present disclosure.

[029] Fig. 3C shows a configuration of sample chambers on test strip 10 according to the methods of the present disclosure.

[030] Fig. 4A is a top view of a reel according to an exemplary disclosed embodiment of the invention.

[031] Fig. 4B is an enlarged tip view of a feature set on the reel of Fig. 4A.

[032] Fig. 5 is a top view of a test card according to a further illustrative embodiment of the invention.

[033] Fig. 6 is a diagram of the manufacturing process before production testing according to a further illustrative embodiment of the invention.

### **DESCRIPTION OF THE EMBODIMENTS**

[034] Reference will now be made in detail to the exemplary embodiments of the invention, examples of which are illustrated in the accompanying drawings. Wherever possible, the same reference numbers will be used throughout the drawings to refer to the same or like parts.

[035] In accordance with an exemplary embodiment, a biosensor manufacturing method is described. Many industries have a commercial need to monitor the concentration of particular constituents in a fluid. The oil refining industry, wineries, and the dairy industry are examples of industries where fluid testing is routine. In the health care field, people such as diabetics, for example, need to monitor various constituents within their bodily fluids using biosensors. A number of systems are available that allow people to test a body fluid (e.g., blood, urine, or saliva), to conveniently monitor the level of a particular fluid constituent, such as, for example, cholesterol, proteins or glucose.

[036] For purposes of this disclosure, "distal" refers to the portion of a test strip further from the fluid source (i.e., closer to the meter) during normal use, and "proximal" refers to the portion closer to the fluid source (e.g., a finger tip with a drop of blood for a glucose test strip) during normal use. The test strip may include a plurality of sample chambers for receiving a user's fluid sample, such as, for example, a blood sample. The sample chambers and test strip of the present specification can be formed using materials and methods described in commonly owned U.S. Patent No. 6,743,635, which is hereby incorporated by reference in its entirety. Accordingly, a sample chamber may include a first opening in the proximal end of the test strip and a second opening for venting the sample chamber. Each sample chamber may be dimensioned so as to be able to draw the blood sample in through the first opening and to hold the blood sample in the sample chamber by capillary action. The test strip can include a tapered section that is narrowest at the proximal end, or can include other indicia in order to make it easier for the user to locate the first opening and apply the blood sample.



[037] A first set of electrodes, such as a working electrode and a counter (or in an exemplary embodiment, proximal) electrode, can be disposed in a first sample chamber optionally along with one or more fill-detect electrodes. A reagent layer is disposed in the first sample chamber and preferably contacts at least the working electrode. The reagent layer may include an enzyme, such as glucose oxidase or glucose dehydrogenase, and a mediator, such as potassium ferricyanide or ruthenium hexamine. The first sample chamber may be configured to permit determination of one or more analytes in a blood sample, such as, for example, glucose. A second set of electrodes may be disposed in a second sample chamber, such as, for example, a proximal electrode and a distal electrode. The electrodes may be spaced at a predetermined distance such that hematocrit may be determined by measurement of electrical impedance between the two electrodes in the second sample chamber.

[038] The test strip has, near its distal end, a plurality of electrical contacts that are electrically connected to the electrodes via conductive traces. In addition, the test strip may also include a second plurality of electrical strip contacts near the distal end of the strip. The second plurality of electrical contacts can be arranged such that they provide, when the strip is inserted into the meter, a distinctly discernable lot code readable by the meter. In some embodiments, the electrical contacts may be at least partially covered with an at least partially conductive material to improve the wear properties of the electrical contacts.

[039] An individual test strip may also include an embedded code relating to data associated with a lot of test strips, or data particular to that individual strip. The embedded information presents data readable by the meter signaling the meter's microprocessor to access and utilize a specific set of stored calibration parameters particular to test strips from a manufacturing lot to which the individual strip belongs, or to an individual test strip. The system may also include a check strip that the user may insert into the meter to check that the instrument is electrically calibrated and functioning properly. The readable code can be read as a signal to access data, such as calibration coefficients, from an on-board memory unit in the meter.

[040] In order to save power, the meter may be battery powered and may stay in a low-power sleep mode when not in use. When the test strip is inserted into the meter, one or more electrical contacts on the test strip form electrical connections with one or more corresponding electrical contacts in the meter. The second plurality of electrical contacts may bridge a pair of electrical contacts in the meter, causing a current to flow through a portion of the second plurality of electrical contacts. The current flow through the second plurality of electrical contacts causes the meter to wake up and enter an active mode. The meter also reads the code information provided by the second plurality and can then identify, for example, the particular test to be performed or a confirmation of proper operating status. Calibration data pertaining to the strip lot, for either the analyte test or the hematocrit test, discussed below, can also be encoded or otherwise represented. In addition, based on the particular code information, the meter can also identify the inserted strip as either a test strip or a check strip. If the meter detects a check strip, it performs a check strip sequence. If the meter detects a test strip, it performs a test strip sequence. In the test strip sequence, the meter validates the working electrode, counter electrode, and, if included, the fill-detect electrodes, by confirming that there are no low-impedance paths between any of these electrodes. If the electrodes are valid, the meter indicates to the user that a sample may be applied to the test strip. The meter then applies a drop-detect voltage between any two suitable electrodes and detects a fluid sample, such as, a blood sample, by detecting a current flow between the working and proximal electrodes (i.e., a current flow through the blood sample as it bridges the working and proximal electrodes). To detect that an adequate sample is present in the sample chamber and that the blood sample has traversed the reagent layer and mixed with the chemical constituents in the reagent layer, the meter may apply a fill-detect voltage to the one or more fill-detect electrodes and measure any resulting current flow. If a resulting electrical property reaches a sufficient level within a predetermined period of time, the meter indicates to the user that adequate sample is present and has mixed with the reagent layer.

[041] The meter can be programmed to wait for a predetermined period of time after initially detecting the blood sample to allow the blood sample to react with

the reagent layer. Alternatively, the meter may be configured to immediately begin taking readings in sequence. During an exemplary fluid measurement sequence using amperometry, the meter applies an assay voltage between the working and proximal electrodes and takes one or more measurements of the resulting current flowing between the working and counter electrodes. The assay voltage is near the redox potential of the chemistry in the reagent layer, and the resulting current is related to the concentration of the particular constituent measured, such as, for example, the glucose level in a blood sample. Voltammetry and coulometry approaches, as known in the art, could also be employed.

[042] In one example, the reagent layer may react with glucose in the blood sample in order to determine the particular glucose concentration. In one example, glucose oxidase or glucose dehydrogenase is used in the reagent layer. During a sample test, the glucose oxidase initiates a reaction that oxidizes the glucose to gluconic acid and reduces a mediator such as ferricyanide or ruthenium hexamine. When an appropriate voltage is applied to a working electrode relative to a counter electrode, the ferrocyanide is oxidized to ferricyanide, thereby generating a current that is related to the glucose concentration in the blood sample.

[043] The test strip may also include a second sample chamber configured to permit determination of hematocrit. The meter can determine hematocrit by measuring the impedance of the blood sample in the second sample chamber by applying an appropriate voltage and/or current and reading suitable measurements to calculate an impedance value. The calculated impedance value correlates with hematocrit, which can vary and can affect glucose determination.

[044] The meter can calculate the glucose level based on the measured current from the first sample chamber and, optionally, enhance that calculation based on the impedance value determined using the second sample chamber. This data along with other calibration data contained within the test strip may permit the meter to determine a glucose level and display the calculated glucose level to the user.

[045] Electrodes positioned within the sample chamber may include a working electrode, a counter electrode, a fill-detect electrode, a proximal electrode,

and a distal electrode. A reagent layer can be disposed in the first sample chamber and may cover at least a portion of the working electrode, which can also be disposed at least partially in the sample chamber. The reagent layer can include, for example, an enzyme, such as glucose oxidase or glucose dehydrogenase, and a mediator, such as potassium ferricyanide or ruthenium hexamine, to facilitate the detection of glucose in blood. It is contemplated that other reagents and/or other mediators can be used to facilitate detection of glucose and other constituents in blood and other body fluids. The reagent layer can also include other components, such as buffering materials (e.g., potassium phosphate), polymeric binders (e.g., hydroxypropyl-methyl-cellulose, sodium alginate, microcrystalline cellulose, polyethylene oxide, hydroxyethylcellulose, and/or polyvinyl alcohol), and surfactants (e.g., Triton X-100 or Surfynol 485).

[046] As mentioned previously, biosensors may inaccurately measure a particular constituent level in blood due to unwanted effects of certain blood components on the method of measurement. For example, the hematocrit level (i.e., the percentage of blood occupied by red blood cells) in blood can erroneously affect a resulting analyte concentration measurement. Thus, it may be desirable to apply chemical additives and/or signal processing techniques as previously described, to reduce the sensitivity of the blood sample to hematocrit. Further, it may be desirable to separately measure hematocrit of a blood sample such that any analyte measurement can be adjusted to correct for hematocrit variations. In accordance with an exemplary embodiment of the present invention, a blood sample may be divided into at least two different regions on a biosensor and tested separately. For example, a blood sample may be diverted into a first sample chamber to undergo an electrochemical test, as described above, to determine, for example, the concentration of glucose within the sample. The blood sample may also be diverted into a second sample chamber to undergo a separate test, as discussed in detail below, to determine the hematocrit level of the blood sample. It is also contemplated that a third sample chamber may be used to perform another determination, such as, for example, a determination of blood sample temperature, a concentration of a second analyte, a second measurement of the first analyte concentration, and/or an on board control to perform a calibration step. In some

embodiments, the second sample chamber may be configured to perform one or more determinations as described for the third sample chamber, as outlined in detail below.

[047] In some embodiments, first and second sample chambers can be dimensioned and configured to draw a blood sample into the sample chambers via capillary action. Each sample chamber may also include one or more electrodes positioned within the sample chambers and configured to contact the blood sample. The first sample chamber may include reagents and electrodes configured to determine a blood glucose concentration. Hematocrit may be measured using the second sample chamber. For example, the second chamber may include a set of electrodes spaced apart at a predetermined distance, and hematocrit may be determined by measuring an impedance of the blood sample between the electrodes. The distance between the electrodes in the second sample chamber can be optimized for measuring hematocrit while the electrodes of the first sample chamber may be configured for glucose determination.

[048] Hematocrit may be determined using any methods known in the art. For example, hematocrit may use electrical, optical, chemical, or any other suitable method. Optical methods may include reflective or transmission techniques. Electrical methods may include amperometric, voltametric, or coulometric. In some embodiments, hematocrit may be determined using an AC excitation, wherein an impedance measurement may be obtained using digital signal processing, analog processing, or a similar suitable technique.

[049] To determine impedance, an AC signal can be applied across a set of electrodes in the second sample chamber. Impedance may include real or complex values, wherein effective, reactive, capacitive and/or resistive parameters may be associated with hematocrit. As explained by the Coulter principle, blood hematocrit can be derived from an impedance measurement obtained by applying an AC signal to the blood sample. More specifically, impedance  $Z_R$  can be measured from the blood sample by dividing the phasor voltage  $V_r$  applied across the electrodes and dividing this value by the phasor current  $I_r$  passing through the electrodes and the blood sample. Thus, the impedance of the blood sample is:

$$Z_R = \frac{V_r}{I_r}$$

[050] Following impedance measurement, hematocrit can be determined by applying the measured impedance value or multiple values at several different frequencies of excitation to an equation, an algorithm, a look-up chart, or any other suitable method. For example, an algorithm may correlate a glucose level with an electrical measurement value up to a threshold value, and above that threshold, a correction value correlated with hematocrit may be applied to any glucose determination. Once the value correlated to the hematocrit level within the blood sample is determined, the value may be used to modify the calculated glucose concentration such that an enhanced or corrected value of the concentration of glucose of the blood sample can be determined. Determining a glucose measurement and/or a hematocrit value may also require incorporating of one or more correction values, such as, for example, for variations in a temperature of a blood sample.

[051] In accordance with another exemplary embodiment of the present invention, a test strip may further comprise a third sample chamber configured to permit determination of a third parameter associated with a blood sample. The third parameter to be measured may be selected from a group consisting of a temperature, a concentration of a second analyte, and an on-board control, as described in detail below.

[052] In some embodiments, one or more sample chambers may be configured to receive a control solution. The control solution may be used to periodically test one or more functions of a meter. For example, a control solution may include a solution of known electrical properties and an electrical measurement of the solution may be performed by the meter. When the meter detects the use of a control solution, it can provide an operational check of both sample chambers functionality to verify the systems measurement integrity. The meter read-out may then be compared to the known glucose value of the solution to confirm that the meter is functioning to an appropriate accuracy. Any measurement of a control solution may be performed using one or more electrodes

of the second sample chamber. In addition, data associated with a measurement of a control solution may be processed, stored and/or displayed using a meter differently to any data associated with a glucose measurement. Such different treatment of data associated with the control solution may permit a meter, or user, to distinguish a glucose measurement, or may permit exclusion of any control measurements when conducting any statistical analysis of glucose measurements.

[053] The present disclosure provides a method for producing a diagnostic test strip 10, as shown in Fig. 1A. Test strip 10 of the present disclosure may be used with a suitable test meter 400, 408, as shown in Figs. 1B and 1C, to detect or measure the concentration of one or more analytes. As shown in Fig. 1A, test strip 10 are planar and elongated in design. However, test strip 10 may be provided in any suitable form including, for example, ribbons, tubes, tabs, discs, or any other suitable form. Furthermore, test strip 10 can be configured for use with a variety of suitable testing modalities, including electrochemical tests, photochemical tests, electro-chemiluminescent tests, and/or any other suitable testing modality.

[054] Test meter 400, 408 may be selected from a variety of suitable test meter types. For example, as shown in Fig. 1B, test meter 400 includes a vial 402 configured to store one or more test strips 10. The operative components of test meter 400 may be contained in a meter cap 404. Meter cap 404 may contain electrical meter components, can be packaged with test meter 400, and can be configured to close and/or seal vial 402. Alternatively, a test meter 408 can include a monitor unit separated from storage vial, as shown in Fig. 1C. Any suitable test meter may be selected to provide a diagnostic test using test strip 10 produced according to the disclosed methods.

#### Test Strip Configuration

[055] With reference to the drawings, FIGS. 2A and 2B show a test strip 10, in accordance with an exemplary embodiment of the present invention. Test strip 10 preferably takes the form of a generally flat strip that extends from a proximal end 12 to a distal end 14. Preferably, test strip 10 is sized for easy handling. For example, test strip 10 can measure approximately 35 mm long (i.e., from proximal end 12 to distal end 14) and approximately 9 mm wide. The strip, however, can be any convenient length and width. For example, a meter with

automated test strip handling may utilize a test strip smaller than 9 mm wide. Additionally, proximal end 12 can be narrower than distal end 14 in order to provide facile visual recognition of the distal end. Thus, test strip 10 can include a tapered section 16, in which the full width of test strip 10 tapers down to proximal end 12, making proximal end 12 narrower than distal end 14. As described in more detail below, the user applies the blood sample to an opening in proximal end 12 of test strip 10. Thus, providing tapered section 16 in test strip 10, and making proximal end 12 narrower than distal end 14, assists the user in locating the opening where the blood sample is to be applied. Further, other visual means, such as indicia, notches, contours or the like are possible.

[056] As shown in FIG. 2B, test strip 10 can have a generally layered construction. Working upwardly from the bottom layer, test strip 10 can include a base layer 18 extending along the entire length of test strip 10. Base layer 18 can be formed from an electrically insulating material and have a thickness sufficient to provide structural support to test strip 10. For example, base layer 18 can be formed from a polyester (e.g., PET), acrylic, and/or other plastic material and be about 0.35 mm thick.

[057] According to the illustrative embodiment, a conductive layer 20 is disposed on base layer 18. Conductive layer 20 includes a plurality of electrodes disposed on base layer 18 near proximal end 12, a plurality of electrical contacts disposed on base layer 18 near distal end 14, and a plurality of conductive regions electrically connecting the electrodes to the electrical contacts. In the illustrative embodiment depicted in FIG. 2A, the plurality of electrodes includes a working electrode 22, a proximal electrode (or counting electrode) 24, a distal electrode (or fill detect-anode) 28, and a fill-detect electrode (or fill-detect cathode) 30. Defined between proximal electrode 24 and distal electrode 28 is an electrically isolated region 26, wherein the distance between electrodes 24 and 28 may be about 1 mm. The electrical contacts can correspondingly include a working electrode contact 32, a proximal electrode contact 34, a distal electrode contact 36, and a fill-detect electrode contact 38. The conductive regions can include a working electrode conductive region 40, electrically connecting working electrode 22 to working electrode contact 32, a proximal electrode conductive region 42, electrically



connecting proximal electrode 24 to proximal electrode contact 36, a distal electrode conductive region 44 electrically connecting distal electrode 28 to distal electrode contact 36, and a fill-detect electrode conductive region 46 electrically connecting fill-detect electrode 30 to fill-detect contact 38. Further, the illustrative embodiment is depicted with conductive layer 20 including an auto-on conductor 48 disposed on base layer 18 near distal end 14.

[058] In addition, the present disclosure provides test strips 10 that include electrical contacts that are resistant to scratching or abrasion. Such test strips 10 can include conductive electrical contacts formed of two or more layers of conductive and/or semi-conductive material. Referring to Fig. 2B, A first lower conductive layer 20 can include a conductive metal, ink, or paste. A second upper layer (not illustrated) can include a conductive ink or paste. Further, in some embodiments, the upper layer can have a resistance to abrasion that is greater than the lower layer. In addition, the second upper layer may have a thickness such that, even when scratched or abraded, the entire thickness of the conductive layer will not be removed, and the electrical contact will continue to function properly. Thus, such test strips 10 can include electrical contacts having material properties and dimensions such that, even when scratched or abraded, test strips 10 will continue to function properly. Further information relating to electrical contacts that are resistant to scratching or abrasion are described in U.S. Patent Application No. 11/458,298 which is incorporated by reference herein in its entirety.

[059] The next layer in the illustrative test strip 10 is a dielectric spacer layer 64 disposed on conductive layer 20. Dielectric spacer layer 64 is composed of an electrically insulating material, such as polyester (e.g., PET), acrylic, and/or other plastic material. Dielectric spacer layer 64 can be about 0.100 mm thick and covers portions of working electrode 22, proximal electrode 24, distal electrode 28, fill-detect electrode 30, and conductive regions 40-46, but in the illustrative embodiment does not cover electrical contacts 32-38 or auto-on conductor 48. For example, dielectric spacer layer 64 can cover substantially all of conductive layer 20 thereon, from a line just proximal of contacts 32 and 34 all the way to proximal end 12, except for a first sample chamber 52 and a second sample chamber 58 extending from proximal end 12. In this way, first sample chamber 52 can define

an exposed portion 54 of working electrode 22, an exposed portion 56 of proximal electrode 24, and an exposed portion 62 of fill-detect electrode 30. Second sample chamber 58 can define an exposed portion 59 of proximal electrode 24 and an exposed portion 60 of distal electrode 28. In some embodiments, first sample chamber 52 may be configured to detect an analyte concentration in a blood sample and second sample chamber 58 may be configured to determine a hematocrit of the blood sample. The shape of sample chambers 52 and 58 may be achieved prior to application on the base layer. Alternatively sample chambers 52 and 58 may be formed subsequently, which may allow for tighter tolerances to be achieved in the formation of the sample chambers 52 and 58.

[060] A cover 72, having a proximal end 74 and a distal end 76, can be attached to dielectric spacer layer 64 via an adhesive layer 78. Cover 72 can be composed of an electrically insulating material, such as polyester, and can have a thickness of about 0.1 mm. Additionally, cover 72 can be transparent.

[061] Adhesive layer 78 can include a polyacrylic or other adhesive and have a thickness of about 0.013 mm. Adhesive layer 78 can consist of sections disposed on spacer layer 64 on opposite sides of first sample chamber 52. A break 84 in adhesive layer 78 extends from a distal end 70 of first sample chamber 52 to an opening 86. Cover 72 can be disposed on adhesive layer 78 such that its proximal end 74 is aligned with proximal end 12 and its distal end 76 is aligned with opening 86. In this way, cover 72 covers first sample chamber 52 and break 84. It is also contemplated that cover 72 may similarly cover second sample chamber 58.

[062] Proximal end 74 of cover 72 can extend from distal end 70 beyond proximal end 12 to create an overhang, as shown in Fig. 2B. The overhang may be formed by extending cover 72 beyond proximal end 12 and/or by removing at least part of base layer 18 or other appropriate material under cover 72 to create a notch or similar structure. This overhang/notch configuration can aid in forming a hanging reservoir for a blood sample, via surface tension, to aid in providing a sufficient sample into first sample chamber 52 and second sample chamber 58. It is also contemplated that various materials, surface coatings (e.g., hydrophilic and/or hydrophobic), or other structure protrusions and/or indentations at proximal end 12 may be used to form a suitable blood sample reservoir.

[063] First sample chamber 52 and second sample chamber 58 may be configured to receive separate portions of a blood sample applied to test strip 10. A proximal end 68 of first sample chamber 52 may define a first opening in first sample chamber 52, through which the blood sample is introduced into first sample chamber 52. At distal end 70 of first sample chamber 52, break 84 may define a second opening in first sample chamber 52, for venting first sample chamber 52 as a fluid sample enters first sample chamber 52. First sample chamber 52 may be dimensioned such that a blood sample applied to its proximal end 68 may be drawn into first sample chamber 52 by capillary action, with break 84 venting first sample chamber 52 through opening 86, as the blood sample enters. Moreover, first sample chamber 52 can advantageously be dimensioned so that the blood sample that enters first sample chamber 52 by capillary action is about 1 micro-liter or less. For example, first sample chamber 52 can have a length (i.e., from proximal end 12 to distal end 70) of about 0.140 inches, a width of about 0.060 inches, and a height (which can be substantially defined by the thickness of dielectric spacer layer 64) of about 0.005 inches. Other dimensions could be used, however.

[064] Proximal end 12 of second sample chamber 58 may define a first opening in second sample chamber 58, through which the blood sample is introduced into second sample chamber 58. Second sample chamber 58 may be dimensioned such that a blood sample applied to its proximal end may be drawn into second sample chamber 58 by capillary action. Additionally, second sample chamber 58 can advantageously be dimensioned so that the blood sample that enters second sample chamber 58 by capillary action is about 0.5 micro-liters or less.

[065] In some embodiments, a secondary sample chamber may be configured for operation with a continuous glucose monitoring system (not shown). Such a system may include systems and/or devices configured to automatically monitor a patient's glucose level. Such systems may periodically sample body fluid containing cellular or biological matter that may affect a glucose determination. Such systems may also benefit by using a secondary sample chamber configured to determine hematocrit, or a similar measurement, using one of more of the methods described here.

[066] Fig. 3A, 3B and 3C show various illustrative embodiments of test strip 10. Specifically, first sample chamber 52 and second sample chamber 58 may be variously configured in test strip 10. As shown in Fig. 3A, first sample chamber 52 and second sample chamber 58 may be arranged in a bifurcated configuration on test strip 10, wherein first sample chamber 52 may be fluidly connected to a blood reservoir 63 and second sample chamber 58 may be fluidly connected to blood reservoir 63. Such a configuration may permit fluid to flow from blood reservoir 63 into first sample chamber 52 (via an inlet) and second sample chamber 58 (via a second inlet) at appropriate flow rates. It is contemplated that first sample chamber 52 and second sample chamber 58 may also share a common inlet.

[067] Fig. 3B shows test strip 10 according to another illustrative embodiment. Test strip 10 may include first sample chamber 52 fluidly connected to second sample chamber 58 such that a blood sample may flow from one sample chamber into another sample chamber. For example, test strip 10 may be configured such that a blood sample applied to proximal end 12 flows into an inlet of second sample chamber 58. The sample may, through capillary action, flow through second sample chamber 58 to an outlet of second sample chamber 58, which may be fluidly connected to an inlet of first sample chamber 52. Again, through capillary action, the blood sample may flow through first sample chamber 52. Such a configuration may permit a blood sample to flow into second sample chamber 58 wherein hematocrit may be determined, and flow into first sample chamber 52 wherein a glucose concentration may be determined. It is also contemplated that sample chambers 52, 58 may be configured such that blood flows from the blood sample into first sample chamber 52, and from first sample chamber 52 into second sample chamber 58.

[068] Fig. 3C shows test strip 10 according to another illustrative embodiment, wherein test strip 10 may include a third sample chamber 61. Third sample chamber 61 may be configured to permit determination of a third parameter associated with the blood sample, such as, for example, a blood sample temperature, a concentration of a second analyte within the blood sample, a second measurement associated with the first analyte, or any suitable measurement. Third sample chamber 61 may include one or more different or

shared components associated with first sample chamber 52 and second sample chamber 58, such as, for example, one or more electrodes, or reagent layers.

[069] In some embodiments, third sample chamber 61 may be configured to provide an on-board control, wherein a function and/or calibration of test strip 10 may be conducted to at least partially confirm the accuracy of a measurement associated with test strip 10. The third sample chamber 61 may be fluidly connected to first and/or second sample chambers 52, 58. These and other configurations of multiple sample chambers within test strip 10 are contemplated within the scope of the present invention.

[070] As shown in FIG. 2B, a reagent layer 90 is disposed in first sample chamber 52, wherein reagent layer 90 may include one or more chemical constituents to enable the level of glucose in the blood sample to be determined electrochemically. Thus, reagent layer 90 may include an enzyme specific for glucose and a mediator, as described above. In addition, reagent layer 90 may also include other components, buffering materials (e.g., potassium phosphate), polymeric binders (e.g., hydroxypropyl-methyl-cellulose, sodium alginate, microcrystalline cellulose, polyethylene oxide, hydroxyethylcellulose, and/or polyvinyl alcohol), and surfactants (e.g., Triton X-100 or Surfynol 485).

[071] As depicted in FIG. 2B, the arrangement of the various layers in illustrative test strip 10 can result in test strip 10 having different thicknesses in different sections. In particular, among the layers above base layer 18, much of the thickness of test strip 10 can come from the thickness of spacer layer 64. Thus, the edge of spacer layer 64 that is closest to distal end 14 can define a shoulder 92 in test strip 10. Shoulder 92 can define a thin section 94 of test strip 10, extending between shoulder 92 and distal end 14, and a thick section 96, extending between shoulder 92 and proximal end 12. The elements of test strip 10 used to electrically connect it to the meter, namely, electrical contacts 32-38 and auto-on conductor 48, can all be located in thin section 94. Accordingly, the connector in the meter can be sized and configured to receive thin section 94 but not thick section 96, as described in more detail below. This can beneficially cue the user to insert the correct end, i.e., distal end 14 in thin section 94, and can prevent the user from inserting the wrong end, i.e., proximal end 12 in thick section 96, into the meter.

Although FIGS. 2A and 2B illustrate an illustrative embodiment of test strip 10, other configurations, chemical compositions and electrode arrangements could be used.

[072] As depicted in FIG. 2A fill-detect electrode 30 can function with working electrode 22 to perform a fill-detect feature, as previously described. Further, working electrode 22 may operate in conjunction with proximal electrode 24 to detection of a constituent of a sample in first sample chamber 52, as described above. Other configurations of electrodes on test strip 10 are possible, such as, for example, multiple fill-detect electrodes and multiple working electrodes.

[073] As depicted in the Fig. 2B, fill-detect electrode 30 is advantageously located on the distal side of reagent layer 90. In this arrangement, the sample introduced into first sample chamber 52 will have traversed reagent layer 90 before reaching fill-detect electrode 30. This arrangement beneficially allows the fill-detect electrode 30 to indicate not only whether sufficient blood sample is present in first sample chamber 52, but also when, concomitantly, the blood sample has sufficiently mixed with the chemical constituents of reagent layer 90.

#### Test Strip Array Configuration

[074] Test strips can be manufactured by forming a plurality of strips in an array along a reel or web of substrate material. The term "reel" or "web" as used herein applies to continuous webs of indeterminate length, or to sheets of determinate length. The individual strips, after being formed, can be separated during later stages of manufacturing. An illustrative embodiment of a batch process of this type is described below. First, an illustrative test strip array configuration is described.

[075] FIG. 4A shows a series of traces 80 formed in a substrate material coated with a conductive layer. Traces 80, formed in the exemplary embodiment by laser ablation, partially form the conductive layers of two rows of ten test strips as shown. In the exemplary embodiment depicted, proximal ends 12 of the two rows of test strips are in juxtaposition in the center of a reel 100. Distal ends 14 of test strips 10 are arranged at the periphery of reel 100. It is also contemplated that the proximal ends 12 and distal ends 14 of test strips 10 can be arranged in the center of reel 100. Alternatively, the two distal ends 14 of test strips 10 can be

arranged in the center of reel 100. The lateral spacing of test strips 10 may be designed to allow a single cut to separate two adjacent test strips. The separation of test strip 10 from reel 100 can electrically isolate one or more conductive components of the separated test strip 10.

[076] As depicted in FIG. 4A, trace 80 for an individual test strip forms a plurality of conductive components; *e.g.*, electrodes, conduction regions and electrode contacts. Trace 80 is comprised of individual cuts made by a laser following a specific trajectory, or vector. A vector can be linear or curvilinear, and define spaces between conductive components that are electrically isolating. Generally a vector is a continuous cut made by the laser beam.

[077] The conductive components can be partially or entirely defined by ablated regions, or laser vectors, formed in the conductive layer. The vectors may only partially electrically isolate the conductive component, as the component can remain electrically connected to other components following laser ablation. The electrical isolation of the conductive components can be achieved following "singulation," when individual test strips are separated from reel or web 100. It is also contemplated that other conductive components may be electrically isolated during the laser ablation process. For example, fill detect electrodes may be isolated with the addition of one or more vectors.

[078] FIG. 4A also includes registration points 102 at the distal end 14 of each test strip on reel 100. Registration points 102 assist the alignment of the layers during lamination, punching, etching, scoring, drilling, heating, compression, molding, printing, and/or other manufacturing processes. It is further contemplated that registration points 102 may be located at locations other than the distal end 14 of each test strip trace 80 on reel 100. High quality manufacturing may require additional registration points 102 to ensure adequate alignment of laminate layers and/or other manufacturing processes, such as, for example, laser ablation of conductive components, reagent deposition, singulation, etc. It is contemplated that registration points 102 may be separated by less than 500 mm and may be less than 10 mm wide.

[079] FIG. 5 shows a "test card" 104 separated from reel 100. Test card 104 can contain a plurality of test strips 10 or traces 80, and a plurality of

conductive components. In the preferred embodiment test card 104 can contain between 6 and 12 test strips 10 or traces 80. In other embodiments, test card 104 can contain a plurality of test strips 10 or traces 80. In the illustrated embodiment, test card 104 can include a lateral array of test strips 10 or traces 80. In other embodiments, test card 104 can include an array or arrays of test strips 10 or traces 80 in longitudinal and/or lateral configurations. It is further contemplated that test strips 10 or traces 80 may be in any arrangement on reel 100 suitable for manufacturing.

[080] Test card 104 contains a plurality of conductive components. Some conductive components can be electrically isolated when test card 104 is removed from reel 100. As shown in FIG. 5, working electrode 22 is electrically isolated. Other embodiments could include additional electrically isolated conductive components not shown in FIG. 5. It may be possible to analyze properties of the electrically isolated conductive components to assess the quality of the manufacturing process. The efficiency of the quality assessment process can be increased by testing at least one of the plurality of electrically isolated conductive components.

#### Batch Manufacturing of Test Strips

[081] Test strip 10 may be manufactured using any suitable manufacturing methods. For example, one or more conductive components may be manufactured using laser ablation employing projected masks or raster scanning methods, screen printing, insert injection molding, and any other suitable techniques. One or more sample chambers, or capillaries, may be formed using a spacer, dielectric build-up, injection molded, laser ablation, or other suitable method. One illustrative embodiment for manufacturing test strip 10 will now be described in detail.

[082] FIGS. 4A through 6 illustrate an exemplary method of manufacturing test strips. Although these figures shows steps for manufacturing test strip 10, as shown in FIGS. 4A through 6, it is to be understood that similar steps can be used to manufacture test strips having other configurations.

[083] With reference to FIG. 5, a plurality of test strips 10 can be produced by forming a structure 120 that includes a plurality of test strip traces 122 on reel 100. Test strip traces 122 include a plurality of traces 80, and can be arranged in



an array that includes a plurality of rows. Each row 124 can include a plurality of test strip traces 122.

[084] The separation process can also be used to electrically isolate conductive components of test strip 10. Laser ablation of the conductive layer may not electrically isolate certain conductive components. The non-isolated conductive components may be isolated by the separation process whereby test strips are separated from reel 100. The separation process may sever the electrical connection, isolating the conductive component. Separating test strip 10 can electrically isolate the counting electrode 24, fill detect-anode 28 and fill-detect cathode 30. The separation process can complete the electrical isolation of conductive components by selectively separating conductive components.

[085] Further, the separation process can provide some or all of the shape of the perimeter of test strips 10. For example, the tapered shape of tapered sections 16 of test strips 10 can be formed during this punching process. Next, a slitting process can be used to separate test strip traces 122 in each row 124 into individual test strips 10. The separation process may include stamping, slitting, scoring and breaking, or any suitable method to separate test strip 10 and/or card 104 from reel 100.

[086] FIGS. 4A and 4B show only one test strip trace 122 (either partially or completely fabricated), in order to illustrate various steps in a preferred method for forming test strip traces 122. In this exemplary approach, test strip traces 122 in integrated structure 120 are all formed on a sheet of material that serves as base layer 18 in the finished test strips 10. The other components in the finished test strips 10 are then built up layer-by-layer on top of base layer 18 to form test strip traces 122. In each of FIGS. 4A and 4B, the outer shape of test strip 10 that would be formed in the overall manufacturing process is shown as a dotted line.

[087] The exemplary manufacturing process employs base layer 18 covered by conductive layer 20. Conductive layer 20 and base layer 18 can be in the form of a reel, ribbon, continuous web, sheet, or other similar structure. Conductive layer 20 can include any suitable conductive or semi-conductor material, such as palladium, gold, platinum, silver, iridium, carbon, indium tin oxide, indium zinc oxide, copper, aluminum, gallium, iron, mercury amalgams, tantalum,

titanium, zirconium, nickel, osmium, rhenium, rhodium palladium, an organometallic, and/or other conductive or semi-conductor materials known in the art. Conductive layer 20 can be formed by sputtering, vapor deposition, screen printing or any suitable manufacturing method. For example, one or more electrodes may be at least partially formed by sputtering, evaporation, electroplating, ultrasonic spraying, pressure spraying, direct writing, shadow mask lithography, lift-off lithography, or laser ablation. Also, the conductive material can be any suitable thickness and can be bonded to base layer 18 by any suitable means.

[088] As shown in FIG. 2A, conductive layer 20 can include working electrode 22, proximal electrode 24, distal electrode 28, and fill-detect cathode 30. Trace 80 can be formed by laser ablation where laser ablation can include any device suitable for removal of the conductive layer in appropriate time and with appropriate precision and accuracy. Various types of lasers can be used for sensor fabrication, such as, for example, solid-state lasers (e.g. Nd:YAG and titanium sapphire), copper vapor lasers, diode lasers, carbon dioxide lasers and excimer lasers. Such lasers may be capable of generating a variety of wavelengths in the ultraviolet, visible and infrared regions. For example, excimer laser provides wavelength of 248 nm, a fundamental Nd:YAG laser gives 1064 nm, a frequency tripled Nd:YAG wavelength is at 355 nm and a Ti:sapphire laser is at approximately 800 nm. The power output of these lasers may vary and is usually in range 10-100 watts.

[089] The laser ablation process can include a laser system. The laser system can include a laser source. The laser system can further include means to define trace 80, such as, for example, a focused beam, projected mask or other suitable technique. The use of a focused laser beam can include a device capable of rapid and accurate controlled movement to move the focused laser beam relative to conductive layer 20. The use of a mask can involve a laser beam passing through the mask to selectively ablate specific regions of conductive layer 20. A single mask can define test strip trace 80, or multiple masks may be required to form test strip trace 80. To form trace 80, the laser system can move relative to conductive layer 20. Specifically, the laser system, conductive layer 20, or both the

laser system and conductive layer 20 may move to allow formation trace 80 by laser ablation. Exemplary devices available for such ablation techniques include Microline Laser system available from LPKF Laser Electronic GmbH (Garbsen, Germany) and laser micro machining systems from Exitech, Ltd (Oxford, United Kingdom).

[090] In the next step, dielectric spacer layer 64 can be applied to conductive layer 20, as illustrated in FIG. 2B. Spacer layer 64 can be applied to conductive layer 20 in a number of different ways. In an exemplary approach, spacer layer 64 is provided as a sheet or web large enough and appropriately shaped to cover multiple test strip traces 80. In this approach, the underside of spacer layer 64 can be coated with an adhesive to facilitate attachment to conductive layer 20. Portions of the upper surface of spacer layer 64 can also be coated with an adhesive in order to provide adhesive layer 78 in each of test strips 10. Various sample chambers can be cut, formed or punched out of spacer layer 64 to shape it before, during or after the application of spacer layer 64 to conductive layer 20. In addition, spacer layer 64 can include adhesive sections and can include a break for each test strip trace. Spacer layer 64 is then positioned over conductive layer 20, as shown in FIG. 2B, and laminated to conductive layer 20. When spacer layer 64 is appropriately positioned on conductive layer 20, exposed electrode portions 54-62 are accessible through sample chambers 52 and 58. Similarly, spacer layer 64 leaves contacts 32-38 and auto-on conductor 48 exposed after lamination.

[091] Alternatively, spacer layer 64 could be applied in other ways. For example, spacer layer 64 can be injection molded onto base layer 18 and a substrate. Spacer layer 64 could also be built up on dielectric layer 50 by screen-printing successive layers of a dielectric material to an appropriate thickness, e.g., about 0.005 inches. A preferred dielectric material comprises a mixture of silicone and acrylic compounds, such as the "Membrane Switch Composition 5018" available from E.I. DuPont de Nemours & Co., Wilmington, Del. Other materials could be used, however.

[092] Additionally, sample chambers can be formed after application of spacer layer 64 on top of base layer 18 and conductive layer 20 via the

aforementioned laser ablation process. This process allows for the removal of the conductive layer within sample chambers.

[093] Reagent layer 90 can then be applied to each test strip structure. In an illustrative approach, reagent layer 90 is applied by dispensing a formulation onto exposed portion 54 of working electrode 22 and letting it dry to form reagent layer 90. Alternatively, other methods, such as screen-printing, spray deposition, piezo and ink jet printing, can be used to apply the composition used to form reagent layer 90.

[094] An exemplary formulation contains 250 mM potassium phosphate at pH 6.75, 175-190 mM ruthenium hexamine, 5000U/mL glucose dehydrogenase, 0.5-2.0% polyethylene oxide, 0.025 - 0.20% NATROSOL 250M (hydroxyethylcellulose), 0.675 - 2.5% Avicel (microcrystalline cellulose), 0.05 - 0.20% Triton-X surfactant and 2.5 -5.0% trehalose. In some embodiments, various constituents may be added to reagent layer 90 to at least partially reduce a hematocrit bias of any measurement. For example, various polymers, molecules, and/or compounds may be added to reagent layer 90 to reduce cell migration and hence may increase the accuracy of a measurement based on an electrochemical reaction. Also, one or more conductive components may be coated with a surface layer (not shown) to at least partially restrict cell migration onto the one or more conductive components. These and other techniques known in the art may be used to reduce hematocrit bias from any measurement.

[095] Cover 72 can then be attached to adhesive layer 78. Cover 72 may be large enough to cover multiple test strip traces 122. Attaching cover 72 can complete the formation of the plurality of test strip traces 122. The plurality of test strip traces 122 can then be separated from each other to form a plurality of test strips 10, as described above.

#### Quality Control Testing of Test Strips

[096] FIG. 6 shows a further illustrative embodiment of a test strip manufacturing method. The manufacturing method utilizes a web 200 containing conductive layer 20 and base layer 18. Conductive layer 20 and base layer 18 can be any suitable material. Web 200 can be any dimension suitable for production of

test strips 10. Web 200 is passed through any suitable device and ablated by process 300.

[097] Ablation 300 can include any suitable ablation process capable of forming conductive components in conductive layer 20. In the illustrative embodiment, ablation 300 is achieved by laser ablation. The ablation process may not electrically isolate all conductive components. For example, counting electrode 24 may not be isolated by laser ablation but can be isolated by subsequent separation from web 200. In the illustrative embodiment, working electrode 22 is electrically isolated during ablation process 300. The proximal electrode 24, distal electrode 28 and fill-detect cathode 30 may not be electrically isolated during ablation process 300. Specifically, subsequent separation process can electrically isolate the proximal electrode 24, distal electrode 28 and fill-detect cathode 30.

[098] Web 200 can be passed through any suitable ablation device at speeds sufficient to produce an appropriate rate of test strip production. The ablation process can be sufficiently rapid to allow the continuous movement of web 200 through the laser ablation device. Alternatively, web 200 can be passed through the ablation device in a non-continuous (i.e., start-and-stop) manner.

[099] The properties of the conductive components formed by ablation process 300 can be analyzed during or following ablation process 300. Analysis of ablation process 300 can include optical, chemical, electrical or any other suitable analysis means. The analysis can monitor the entire ablation process, or part of the ablation process. For example, the analysis can include monitoring vector formation to ensure the dimensions of the formed vector are within predetermined tolerance ranges.

[0100] Quality control analysis, which can be performed during or upon completion of the manufacturing process, can also include monitoring the effectiveness and/or efficiency of the vector formation process. In particular, the width of the resulting vectors can be monitored to ensure acceptable accuracy and precision of the cuts in conductive layer 20. For example, the quality of the laser ablation process can be analyzed by monitoring the surface of conductive layer 20 and/or base layer 18 following ablation. Partial ablation of base layer 18 can indicate that the laser power is set too high or the beam is traveling too slowly. By

contrast, a partially ablated conductive layer may indicate insufficient laser power or that the beam is traveling too quickly. Incomplete ablation of gaps may result in the formation of vectors that are not electrically isolating between conductive components.

[0101] In the illustrative embodiment, the dimensions of working electrode 22 can be analyzed to determine the quality of the manufacturing process. For example optical analysis (not shown) can monitor the width of working electrode 22 to ensure sufficient accuracy of ablation process 300. Further, the alignment of working electrode 22 relative to registration points 102 can be monitored. Optical analysis can be performed by using VisionPro system from Cognex Vision Systems (Natick, Massachusetts).

[0102] As described above, the ablation process produces an array of test strips 202 on web 200. Following formation of test strip array 202 and corresponding conductive components, dielectric spacer layer 64 is laminated to conductive layer 20. A spacer lamination process 302 can include registration points 102 to correctly align spacer layer 64 with conductive layer 20. Spacer layer 64 may contain registration points 102 corresponding to registration points 102 of test strip array 202. Spacer lamination process may output a three layer laminate 204.

[0103] A test card 206 may be separated from three layer laminate 204. The separation may be achieved using punching, slitting, cutting, or any other appropriate process. Test card 206 can be analyzed by a test card analysis process 306 to test the quality of any previous manufacturing process. Test card analysis process 306 can include optical, electrical, chemical or any other suitable means for testing test card 206. In an illustrative embodiment, the electrical properties of working electrode 22 can be tested. At least one of the plurality of working electrodes 22 of test card 206 can be analyzed for electrochemical and surface properties. For example, chronoamperometry can be used to test working electrode 22. Chronoamperometry is an electrochemical technique that uses a voltage signal for excitation and measures current generated as a result of the excitation as a function of time.

[0104] Further, test card analysis process 306 may include measuring the width of space 26 between proximal electrode 24 and distal electrode 28 for accuracy. Additionally, a test card 104 may comprise test strips 10 in which sample chambers 52 and 58 have been formed, as discussed above. Under such circumstances test card analysis process 306 may include testing at least one of sample chambers 52 and 58 to determine if they have the dimensions that fit within predetermined tolerances, for example.

[0105] The results of test card analysis process 306 can be compared to previous manufacturing process. Alternatively, the results of test card analysis process 306 may be compared to modeled or simulated results using computational methods. The results can be used to ensure high-quality manufacturing processes. Deviation from acceptable or expected results may require altering upstream manufacturing processes, or altering downstream manufacturing processes to address the deviations. Following acceptance of the results of test card analysis process 306, the quality of upstream manufacturing processes can be confirmed.

[0106] Following a satisfactory feedback 308 from test card analysis process 306, the chemistry can be applied to three-layer laminate 204 by a chemistry application process 310. A resulting laminate 208 can contain any appropriate reagent suitable for the specific test strip. A reagent application process 310 can include any appropriate process. In the preferred embodiment, quality control testing is not performed following reagent application process 310. In other embodiments, quality control analysis can be conducted following reagent application process 310. For example, quality control analysis can monitor the effectiveness of the chemistry application. Specifically, optical analysis may be required to determine the extent of reagent covering working electrode 22 and/or counter electrode 24. Alternatively, any previous or upstream manufacturing process can be tested following formation of laminate 208.

[0107] Following reagent application process 310, cover 72 can be applied to laminate 208 using any appropriate cover application process 312. Cover 72 may be centered on laminate 208. The resulting laminate 210 can be tested to ensure the quality of the cover application process 312. For example, optical

means can be used to monitor the alignment of cover 72 to laminate 210. Alternatively, laminate 210 can be tested to ensure the quality of any upstream manufacturing process as described previously. Following cover application process 312, laminate 210 can be moved to a production testing 314.

[0108] The manufacturing process can be halted at any stage based upon the results of the quality control testing during manufacturing or production. Alternatively, one or more manufacturing processes can be adjusted based on the results of the quality control analysis. Quality control tests can be conducted in real time, and/or may include analysis of test cards removed from the production line. If the quality control testing is performed on test cards taken out of the production line, any production of the same lot or batch can be intercepted in the manufacturing process downstream of the quality control testing. Test card 206 can contain addressable information, identifying where the test card was removed from the production line. Consequently any deviations from appropriate manufacturing quality can be isolated to specific regions of the production line.

#### Conclusion

[0109] In summary, determining hematocrit levels by measuring the impedance of a blood sample in a separate sample chamber has a number of advantages. It can be applied to many biosensors, not just oxidation-based glucose sensors. It has a high degree of accuracy and precision in regards to measuring and correcting for hematocrit since the presence of a separate chamber allows for optimizing the distance between the proximal and distal electrode specifically for measuring impedance of a blood sample. Further, since the impedance measurement can occur concurrently with the electrochemical measurement in another sample chamber, the amount of test time can be kept to a minimum.

[0110] While various test strip structures and manufacturing methods are described as possible candidates for use to measure HCT, they are not intended to be limiting of the claimed invention. Unless expressly noted, the particular test strip structures and manufacturing methods are listed merely as examples and are not intended to be limiting of the invention as claimed. Other embodiments of the invention will be apparent to those skilled in the art from consideration of the



specification and practice of the invention disclosed herein. It is intended that the specification and examples be considered as exemplary only, with a true scope and spirit of the invention being indicated by the following claims.

WHAT IS CLAIMED IS:

1. A biosensor, comprising:  
a base layer;  
a first capillary disposed on the base layer configured to electrochemically determine a concentration of a first analyte in a blood sample, wherein the first capillary includes a first set of at least one electrode; and  
a second capillary disposed on the base layer configured to determine a value correlating to the hematocrit level of the blood sample, wherein the second capillary includes a second set of at least one electrode.
2. The biosensor of claim 1, wherein an exit port of the first capillary is fluidly connected to an entry port of the second capillary.
3. The biosensor of claim 1, wherein an entry port of the first capillary is fluidly connected to an entry port of the second capillary.
4. The biosensor of claim 1, further including a third capillary configured to permit determination of a third parameter associated with the blood sample, wherein the third capillary includes a third set of electrodes.
5. The biosensor of claim 4, wherein an entry port of the first capillary is fluidly connected to an entry port of the second capillary and fluidly connected to an entry port of the third capillary.
6. The biosensor of claim 4, wherein the third parameter is selected from a group consisting of a temperature, a concentration of a second analyte, and an on-board control.
7. The biosensor of claim 1, wherein the first capillary further includes a reagent layer.
8. The biosensor of claim 7, wherein the reagent layer includes at least one of glucose oxidase, glucose dehydrogenase, potassium ferricyanide, and ruthenium hexamine.
9. The biosensor of claim 7, wherein the reagent layer is deposited using a process selected from the group consisting of screen-printing, spray deposition, piezo, pipetting, and ink jet printing.

10. The biosensor of claim 1, wherein the first set of electrodes includes at least one of a working electrode, a proximal electrode, and a fill-detect electrode.
11. The biosensor of claim 1, wherein the first set of electrodes and the second set of electrodes share the at least one electrode.
12. The biosensor of claim 1, further including at least one of an electrical contact, an auto-on conductor, and a coding region.
13. The biosensor of claim 12, wherein an at least partially conductive layer at least partially covers at least one of the electrical contact, the auto-on conductor, and the coding region.
14. The biosensor of claim 1, wherein the at least one electrode is at least partially formed from at least one of palladium, gold, platinum, silver, iridium, carbon, indium tin oxide, indium zinc oxide, copper, aluminum, gallium, iron, mercury amalgams, tantalum, titanium, zirconium, nickel, osmium, rhenium, rhodium palladium, an organometallic, and a metallic alloy.
15. The biosensor of claim 1, wherein the at least one electrode is at least partially formed using at least one process selected from the group consisting of sputtering, evaporation, electroplating, ultrasonic spraying, pressure spraying, direct writing, shadow mask lithography, lift-off lithography, and laser ablation.
16. The biosensor of claim 1, wherein the biosensor includes a generally planar base layer.
17. The biosensor of claim 16, wherein the generally planar base layer includes at least one of an acrylic and a polyester.
18. The biosensor of claim 1, wherein the biosensor further includes a dielectric spacer layer at least partially deposited on the at least one electrode.
19. The biosensor of claim 18, wherein the dielectric spacer layer includes at least one of an acrylic and a polyester.
20. The biosensor of claim 18, wherein the biosensor further includes an adhesive layer disposed between the dielectric spacer layer and the at least one electrode.
21. The biosensor of claim 1, further including a second plurality of electrical contacts that include a code with data relating to the biosensor.

22. An analyte testing system, comprising:  
a meter system for making a measurement of an analyte concentration in a sample, wherein the meter system is configured to use the biosensor of claim 1.
23. The analyte testing system of claim 22, wherein the meter system utilizes the determined hematocrit value to enhance calculating the concentration of the first analyte.
24. A method for manufacturing a biosensor, comprising:  
at least partially forming a plurality of electrodes on a generally planar base layer;  
forming a first capillary on the base layer, wherein the first capillary includes a first set of at least one electrode selected from the plurality of at least partially formed electrodes; and  
forming a second capillary on the base layer, wherein the second capillary includes a second set of at least one electrode selected from the plurality of at least partially formed electrodes.
25. The method of claim 24, wherein an exit port of the first capillary is fluidly connected to an entry port of the second capillary.
26. The method of claim 24, wherein an entry port of the first capillary is fluidly connected to an entry port of the second capillary.
27. The method of claim 24, further including a third capillary configured to permit determination of a third parameter associated with the blood sample, wherein the third capillary includes a third set of electrodes.
28. The method of claim 27, wherein an entry port of the first capillary is fluidly connected to an entry port of the second capillary and fluidly connected to an entry port of the third capillary.
29. The method of claim 27, wherein the third parameter is selected from a group consisting of a temperature, a concentration of a second analyte, and an on-board control.
30. The method of claim 24, wherein the first capillary further includes a reagent layer.

31. The method of claim 30, wherein the reagent layer includes at least one of glucose oxidase, glucose dehydrogenase, potassium ferricyanide, and ruthenium hexamine.

32. The method of claim 30, wherein the reagent layer is deposited using a process selected from the group consisting of screen-printing, spray deposition, piezo, pipetting, and ink jet printing.

33. The method of claim 24, wherein the first set of electrodes includes at least one of a working electrode, a proximal electrode, and a fill-detect electrode.

34. The method of claim 24, wherein the first set of electrodes and the second set of electrodes share the at least one electrode.

35. The method of claim 24, further including at least one of an electrical contact, an auto-on conductor, and a coding region.

36. The method of claim 35, wherein an at least partially conductive layer at least partially covers at least one of the electrical contact, the auto-on conductor, and the coding region.

37. The method of claim 24, wherein the at least one electrode is at least partially formed from at least one of palladium, gold, platinum, silver, iridium, carbon, indium tin oxide, indium zinc oxide, copper, aluminum, gallium, iron, mercury amalgams, tantalum, titanium, zirconium, nickel, osmium, rhenium, rhodium palladium, an organometallic, and a metallic alloy.

38. The method of claim 24, wherein the at least one electrode is at least partially formed using at least one process selected from the group consisting of sputtering, evaporation, electroplating, ultrasonic spraying, pressure spraying, direct writing, shadow mask lithography, lift-off lithography, and laser ablation.

39. The method of claim 24, wherein the generally planar base layer includes at least one of an acrylic and a polyester.

40. The method of claim 24, wherein the biosensor further includes a dielectric spacer layer at least partially deposited on the at least one electrode.

41. The method of claim 40, wherein the dielectric spacer layer includes at least one of an acrylic and a polyester.

42. The method of claim 40, wherein the biosensor further includes an adhesive layer disposed between the dielectric spacer layer and the at least one electrode.

43. The method of claim 24, further including a second plurality of electrical contacts that include a code with data relating to the biosensor.

44. An analyte testing system comprising a meter system for making a measurement of an analyte concentration in a sample, the meter utilizing the biosensor of claim 24.

45. The analyte testing system of claim 44, wherein the meter system utilizes the determined hematocrit value to enhance calculating the concentration of the first analyte.

46. A reel for manufacturing biosensors, comprising:

a generally planar base layer including a plurality of at least partially formed electrodes;

a first capillary on the base layer, wherein the first capillary includes a first set of at least one electrode selected from the plurality of at least partially formed electrodes; and

a second capillary on the base layer, wherein the second capillary includes a second set of at least one electrode selected from the plurality of at least partially formed electrodes.

47. The reel of claim 46, further including a plurality of registration points formed on the generally planar base layer.

48. The reel of claim 46, wherein the plurality of registration points are used to help align the base layer during at least one of the lamination, punching, etching, scoring, drilling, heating, compression, molding, printing, laser ablation of conductive components, reagent deposition, or singulation processes.

49. The reel of claim 46, wherein the plurality of registration points are separated by less than 500 mm.

50. The reel of claim 46, wherein at least one of the plurality of registration points is less than 10 mm wide.

51. The reel of claim 46, wherein an exit port of the first capillary is fluidly connected to an entry port of the second capillary.

52. The reel of claim 46, wherein an entry port of the first capillary is fluidly connected to an entry port of the second capillary.

53. The reel of claim 46, further including a third capillary configured to permit determination of a third parameter associated with the blood sample, wherein the third capillary includes a third set of electrodes.

54. The reel of claim 53, wherein an entry port of the first capillary is fluidly connected to an entry port of the second capillary and fluidly connected to an entry port of the third capillary.

55. The reel of claim 53, wherein the third parameter is selected from a group consisting of a temperature, a concentration of a second analyte, and an on-board control.

56. The reel of claim 46, wherein the first capillary further includes a reagent layer.

57. The reel of claim 56, wherein the reagent layer includes at least one of glucose oxidase, glucose dehydrogenase, potassium ferricyanide, and ruthenium hexamine.

58. The reel of claim 56, wherein the reagent layer is deposited using a process selected from the group consisting of screen-printing, spray deposition, piezo, pipetting, and ink jet printing.

59. The reel of claim 46, wherein the first set of electrodes includes at least one of a working electrode, a proximal electrode, and a fill-detect electrode.

60. The reel of claim 46, wherein the first set of electrodes and the second set of electrodes share the at least one electrode.

61. The reel of claim 46, further including at least one of an electrical contact, an auto-on conductor, and a coding region.

62. The reel of claim 61, wherein an at least partially conductive layer at least partially covers at least one of the electrical contact, the auto-on conductor, and the coding region.

63. The reel of claim 46, wherein the at least one electrode is at least partially formed from at least one of palladium, gold, platinum, silver, iridium, carbon, indium tin oxide, indium zinc oxide, copper, aluminum, gallium, iron,

mercury amalgams, tantalum, titanium, zirconium, nickel, osmium, rhenium, rhodium palladium, an organometallic, and a metallic alloy.

64. The reel of claim 46, wherein the at least one electrode is at least partially formed using at least one process selected from the group consisting of sputtering, evaporation, electroplating, ultrasonic spraying, pressure spraying, direct writing, shadow mask lithography, lift-off lithography, and laser ablation.

65. The reel of claim 46, wherein the generally planar base layer includes at least one of an acrylic and a polyester.

66. The reel of claim 46, wherein the biosensor further includes a dielectric spacer layer at least partially deposited on the at least one electrode.

67. The reel of claim 66, wherein the dielectric spacer layer includes at least one of an acrylic and a polyester.

68. The reel of claim 66, wherein the biosensor further includes an adhesive layer disposed between the dielectric spacer layer and the at least one electrode.

69. The reel of claim 46, further including a second plurality of electrical contacts that include a code with data relating to the reel.

70. An analyte testing system comprising a meter system for making a measurement of an analyte concentration in a sample, the meter utilizing the biosensors of claim 46.

71. The analyte testing system of claim 70, wherein the meter system utilizes the determined hematocrit value to enhance calculating the concentration of the first analyte.

72. A method of manufacturing a plurality of test strips for a biosensor, comprising:

forming a reel containing a base layer;

forming a plurality of electrodes on the base layer; and

partially forming a test strip, wherein the test strip includes a first capillary on the base layer including at least one of the plurality of electrodes and the test strip further includes a second capillary on the base layer including at least one of the plurality of electrodes.



73. The method of claim 72, wherein the reel includes a plurality of registration points.

74. The method of claim 72, wherein an exit port of the first capillary is fluidly connected to an entry port of the second capillary.

75. The method of claim 72, wherein an entry port of the first capillary is fluidly connected to an entry port of the second capillary.

76. The method of claim 72, further including a third capillary configured to permit determination of a third parameter associated with the blood sample, wherein the third capillary includes a third set of electrodes.

77. The method of claim 76, wherein an entry port of the first capillary is fluidly connected to an entry port of the second capillary and fluidly connected to an entry port of the third capillary.

78. The method of claim 76, wherein the third parameter is selected from a group consisting of a temperature, a concentration of a second analyte, and an on-board control.

79. The method of claim 72, wherein the first capillary further includes a reagent layer.

80. The method of claim 79, wherein the reagent layer includes at least one of glucose oxidase, glucose dehydrogenase, potassium ferricyanide, and ruthenium hexamine.

81. The method of claim 79, wherein the reagent layer is deposited using a process selected from the group consisting of screen-printing, spray deposition, piezo, pipetting, and ink jet printing.

82. The method of claim 72, wherein the first set of electrodes includes at least one of a working electrode, a proximal electrode, and a fill-detect electrode.

83. The method of claim 72, wherein the first set of electrodes and the second set of electrodes share the at least one electrode.

84. The method of claim 72, further including at least one of an electrical contact, an auto-on conductor, and a coding region.

85. The method of claim 84, wherein an at least partially conductive layer at least partially covers at least one of the electrical contact, the auto-on conductor, and the coding region.

86. The method of claim 72, wherein the at least one electrode is at least partially formed from at least one of palladium, gold, platinum, silver, iridium, carbon, indium tin oxide, indium zinc oxide, copper, aluminum, gallium, iron, mercury amalgams, tantalum, titanium, zirconium, nickel, osmium, rhenium, rhodium palladium, an organometallic, and a metallic alloy.

87. The method of claim 72, wherein the at least one electrode is at least partially formed using at least one process selected from the group consisting of sputtering, evaporation, electroplating, ultrasonic spraying, pressure spraying, direct writing, shadow mask lithography, lift-off lithography, and laser ablation.

88. The method of claim 72, wherein the biosensor includes a generally planar base layer.

89. The method of claim 88, wherein the generally planar base layer includes at least one of an acrylic and a polyester.

90. The method of claim 72, wherein the biosensor further includes a dielectric spacer layer at least partially deposited on the at least one electrode.

91. The method of claim 90, wherein the dielectric spacer layer includes at least one of an acrylic and a polyester.

92. The method of claim 90, wherein the biosensor further includes an adhesive layer disposed between the dielectric spacer layer and the at least one electrode.

93. The method of claim 72, further including a second plurality of electrical contacts that include a code with data relating to the plurality of test strips.

94. An analyte testing system comprising a meter system for making a measurement of an analyte concentration in a sample, the meter utilizing the biosensor of claim 72.

95. The analyte testing system of claim 94, wherein the meter system utilizes the determined hematocrit value to enhance calculating the concentration of the first analyte.

96. A test card for quality control analysis of biosensors, comprising:  
a base layer, wherein the base layer includes a plurality of electrodes;  
a plurality of partially formed test strips, wherein each test strip includes a first capillary on the base layer including at least one of the plurality of

electrodes and each test strip further includes a second capillary on the base layer including at least one of the plurality of electrodes.

97. The test card of claim 96, wherein an exit port of the first capillary is fluidly connected to an entry port of the second capillary.

98. The test card of claim 96, wherein an entry port of the first capillary is fluidly connected to an entry port of the second capillary.

99. The test card of claim 96, further including a third capillary configured to permit determination of a third parameter associated with the blood sample, wherein the third capillary includes a third set of electrodes.

100. The test card of claim 99, wherein an entry port of the first capillary is fluidly connected to an entry port of the second capillary and fluidly connected to an entry port of the third capillary.

101. The test card of claim 99, wherein the third parameter is selected from a group consisting of a temperature, a concentration of a second analyte, and an on-board control.

102. The test card of claim 96, wherein the first capillary further includes a reagent layer.

103. The test card of claim 102, wherein the reagent layer includes at least one of glucose oxidase, glucose dehydrogenase, potassium ferricyanide, and ruthenium hexamine.

104. The test card of claim 102, wherein the reagent layer is deposited using a process selected from the group consisting of screen-printing, spray deposition, piezo, pipetting, and ink jet printing.

105. The test card of claim 96, wherein the first set of electrodes includes at least one of a working electrode, a proximal electrode, and a fill-detect electrode.

106. The test card of claim 96, wherein the first set of electrodes and the second set of electrodes share the at least one electrode.

107. The test card of claim 96, further including at least one of an electrical contact, an auto-on conductor, and a coding region.

108. The test card of claim 107, wherein an at least partially conductive layer at least partially covers at least one of the electrical contact, the auto-on conductor, and the coding region.

109. The test card of claim 96, wherein the at least one electrode is at least partially formed from at least one of palladium, gold, platinum, silver, iridium, carbon, indium tin oxide, indium zinc oxide, copper, aluminum, gallium, iron, mercury amalgams, tantalum, titanium, zirconium, nickel, osmium, rhenium, rhodium palladium, an organometallic, and a metallic alloy.

110. The test card of claim 96, wherein the at least one electrode is at least partially formed using at least one process selected from the group consisting of sputtering, evaporation, electroplating, ultrasonic spraying, pressure spraying, direct writing, shadow mask lithography, lift-off lithography, and laser ablation.

111. The test card of claim 96, wherein the biosensor includes a generally planar base layer.

112. The test card of claim 111, wherein the generally planar base layer includes at least one of an acrylic and a polyester.

113. The test card of claim 96, wherein the biosensor further includes a dielectric spacer layer at least partially deposited on the at least one electrode.

114. The test card of claim 113, wherein the dielectric spacer layer includes at least one of an acrylic and a polyester.

115. The test card of claim 113, wherein the biosensor further includes an adhesive layer disposed between the dielectric spacer layer and the at least one electrode.

116. The test card of claim 96, further including a second plurality of electrical contacts that include a code with data relating to the biosensor.

117. An analyte testing system comprising:  
a meter system for making a measurement of an analyte concentration in a sample, wherein the meter system is configured to use at least one of the plurality of partially formed test strips of claim 96.

118. The analyte testing system of claim 117, wherein the meter system utilizes the determined hematocrit value to enhance calculating the concentration of the first analyte.

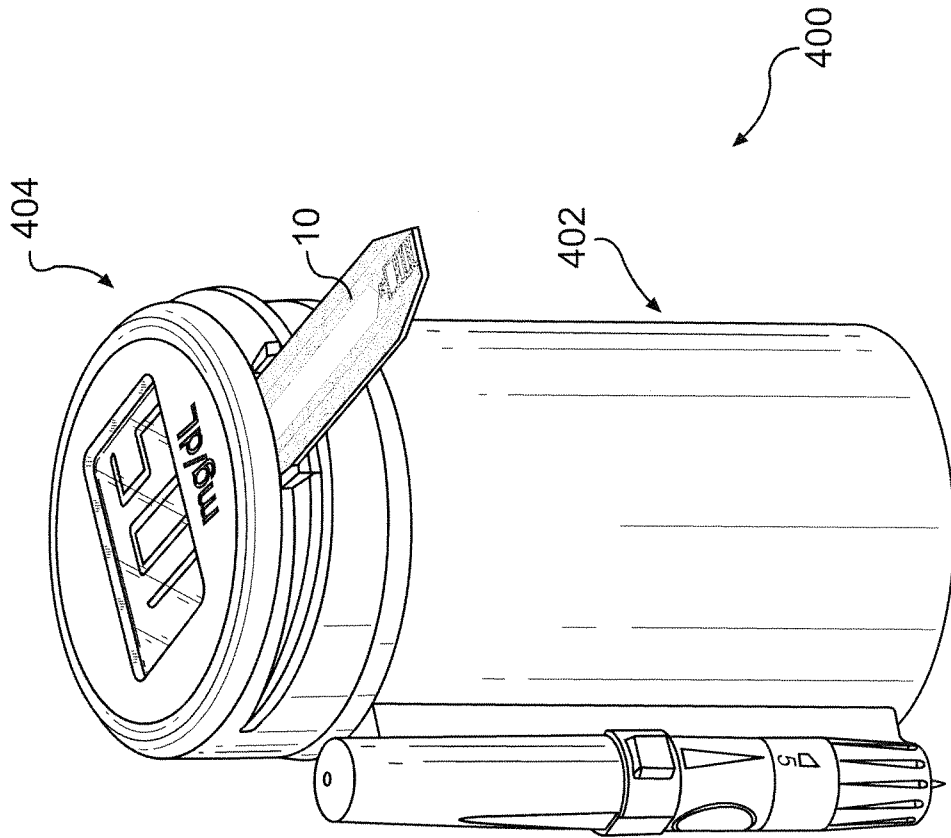

**FIG. 1B**

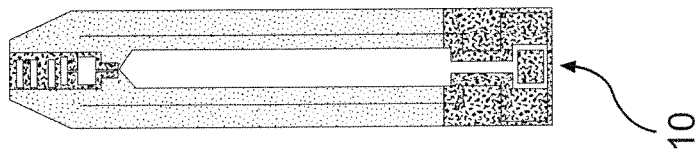

**FIG. 1A**

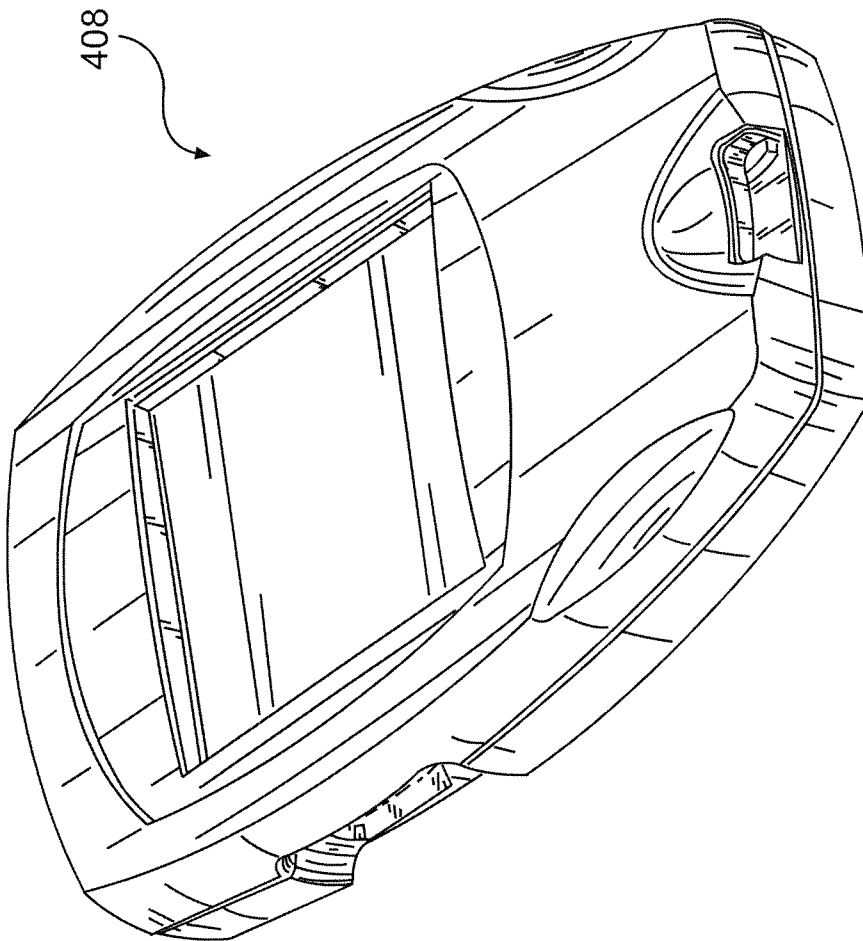

**FIG. 1C**

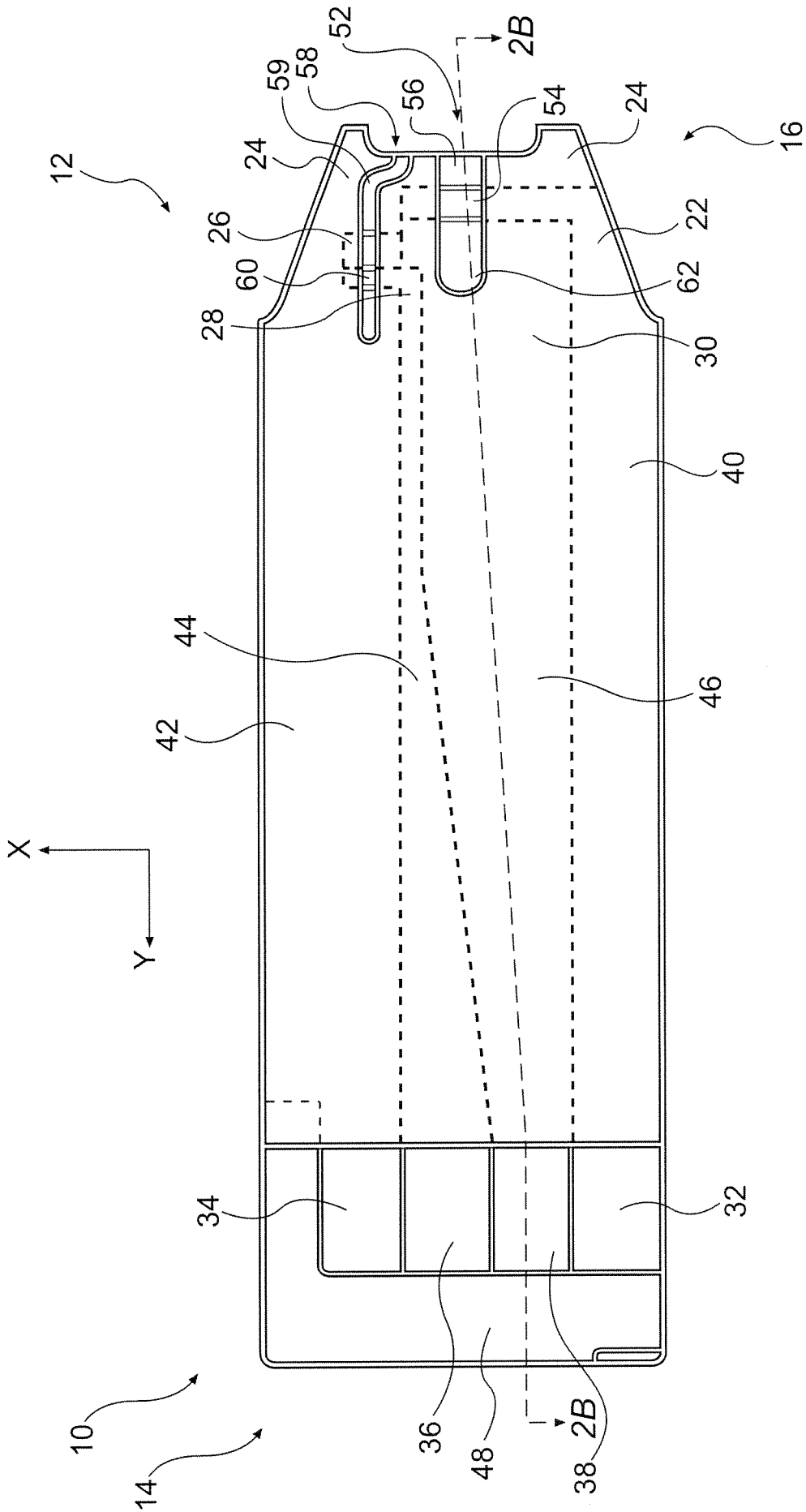

**FIG. 2A**

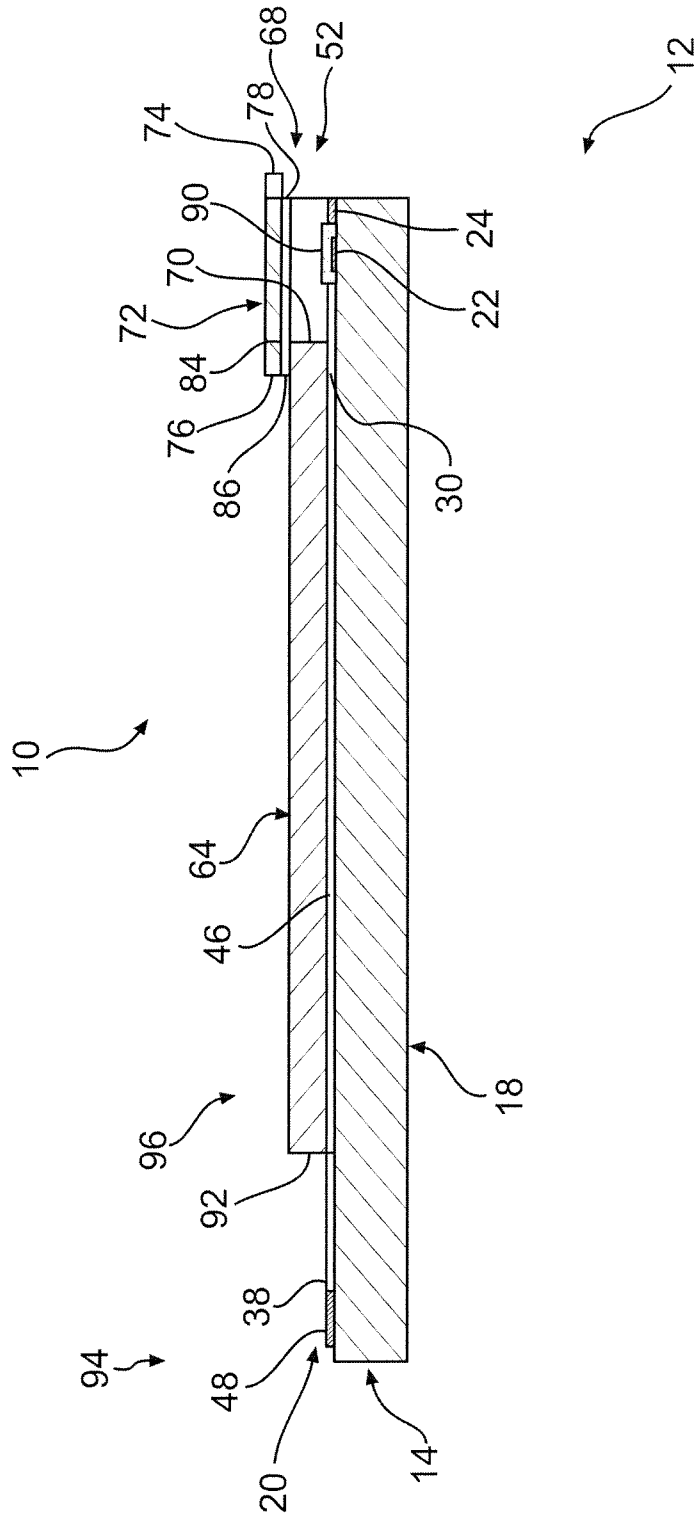
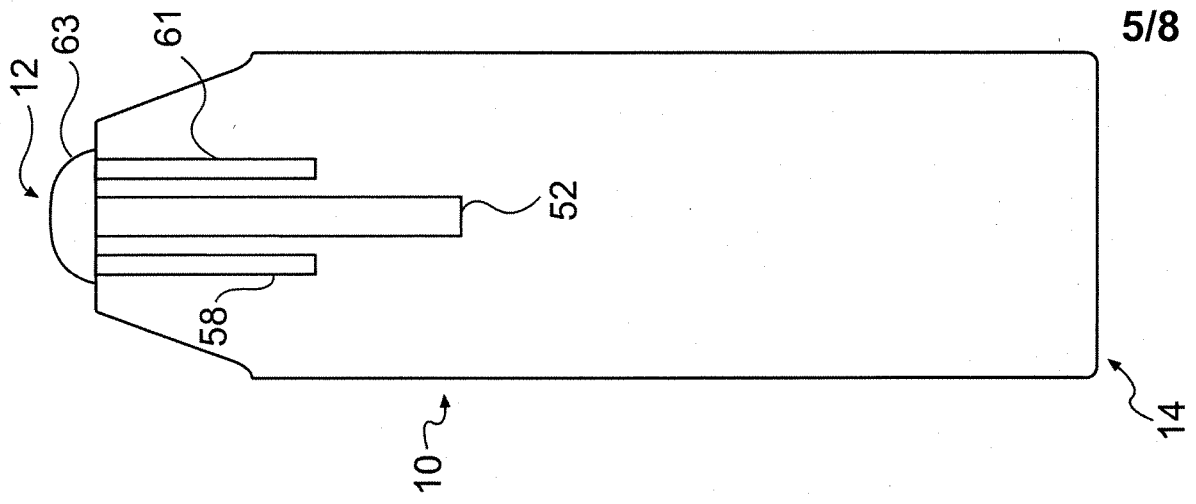
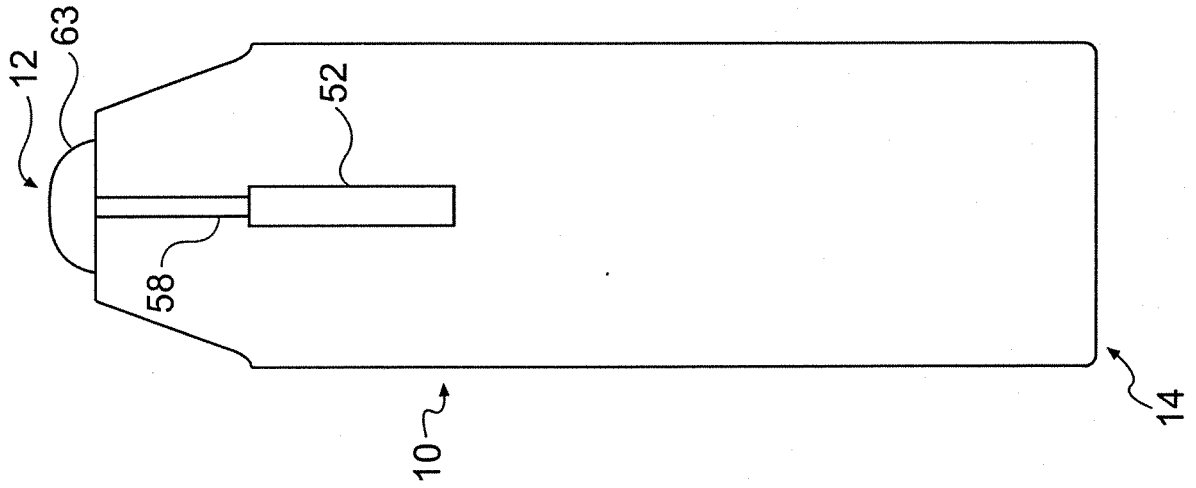

FIG. 2B

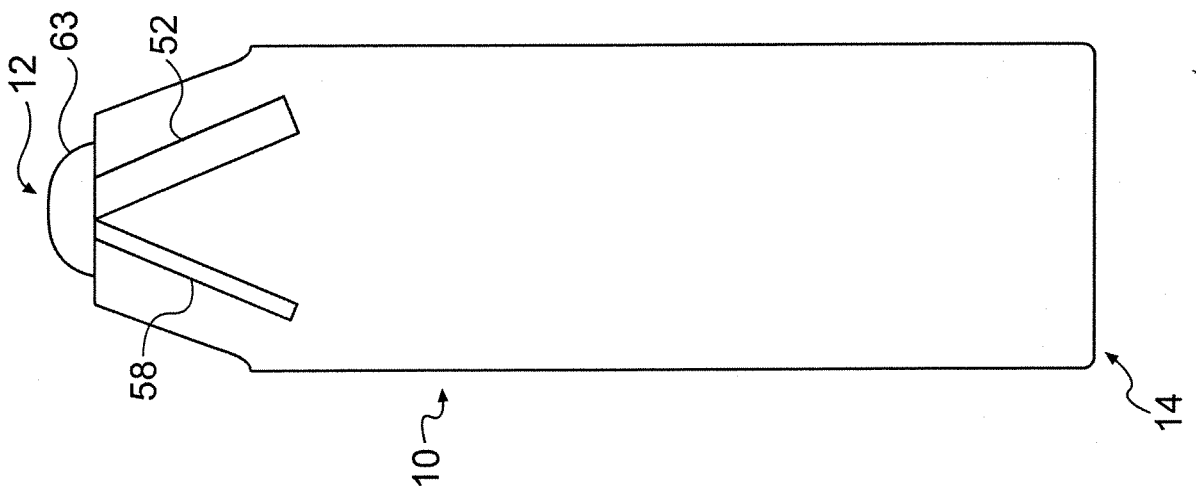



**FIG. 3A**



**FIG. 3B**



**FIG. 3C**

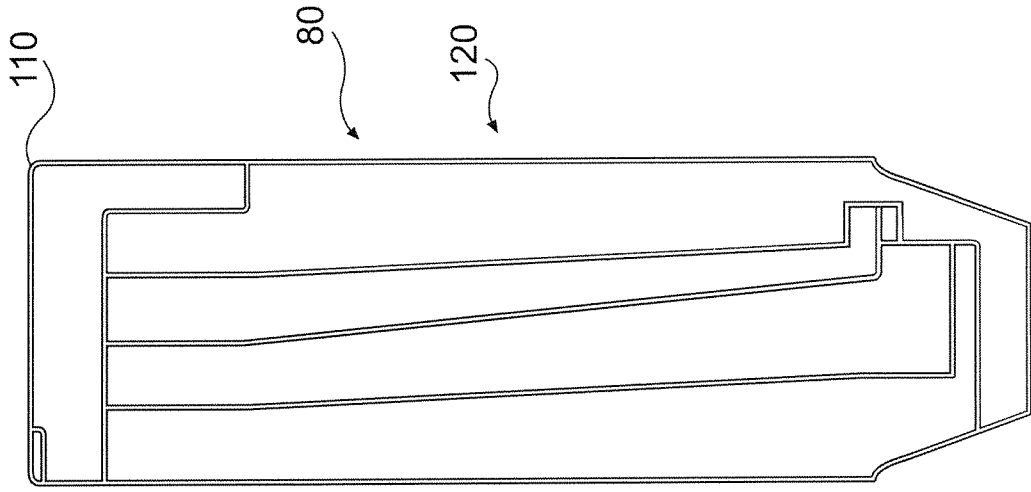

**FIG. 4B**

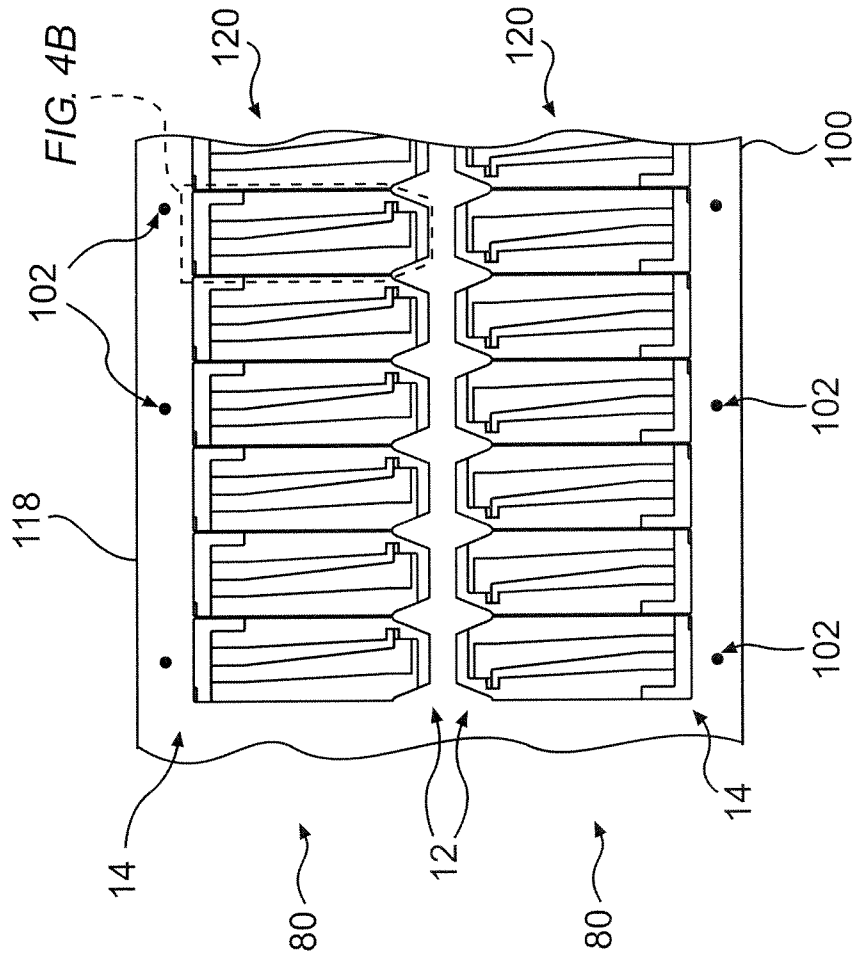

**FIG. 4A**

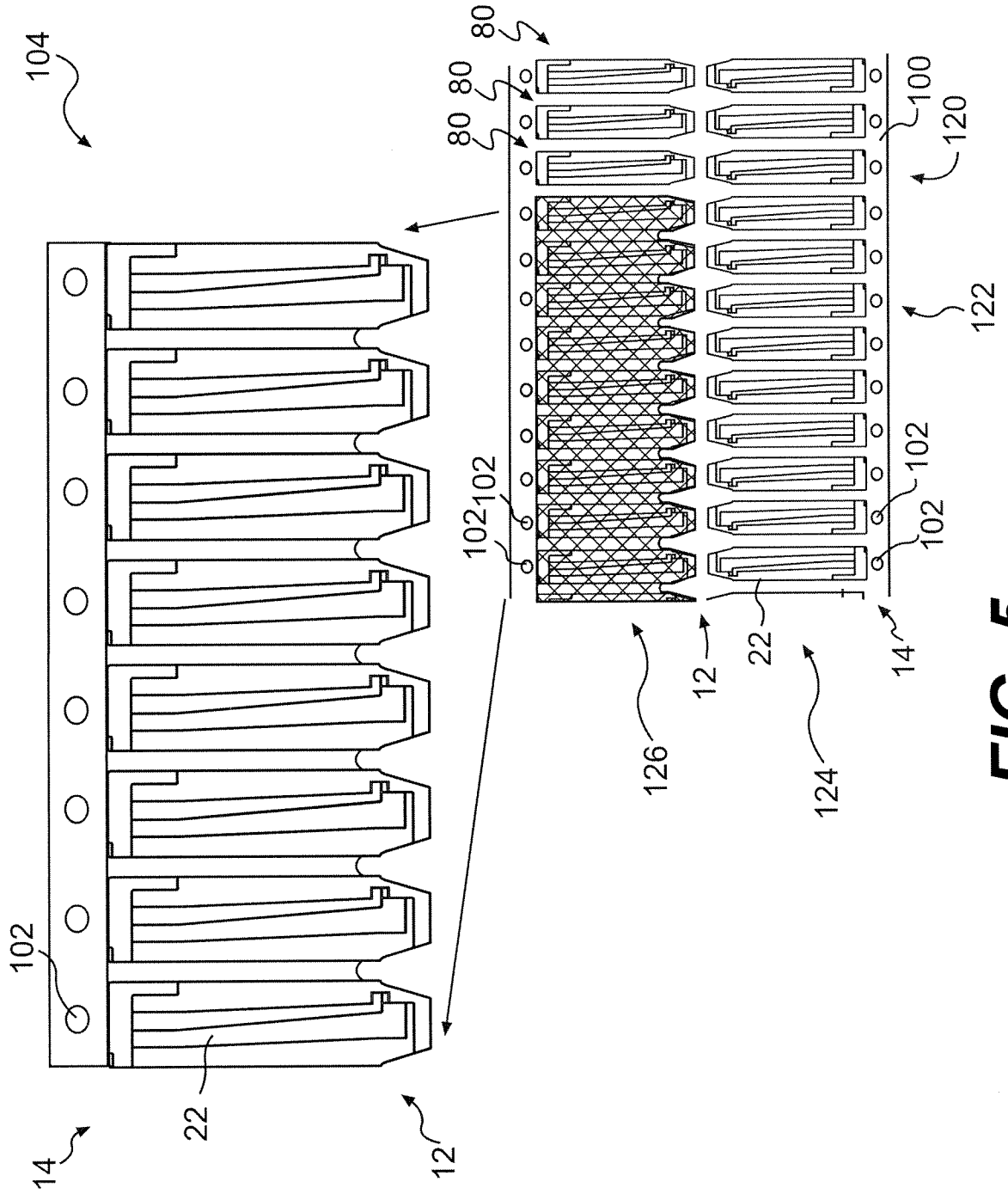

**FIG. 5**

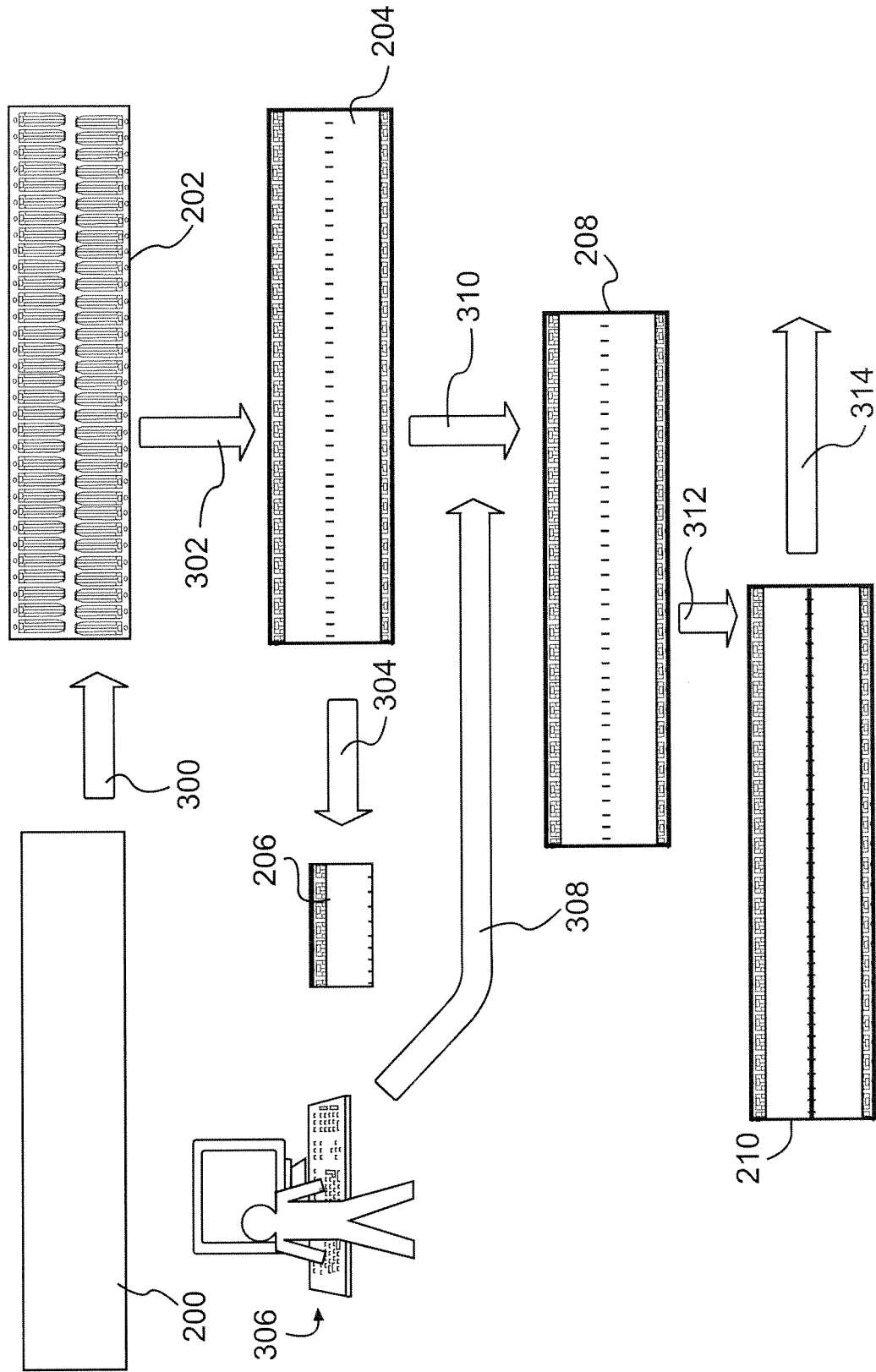

**FIG. 6**

INTERNATIONAL SEARCH REPORT

International application No  
PCT/US2007/077236

A. CLASSIFICATION OF SUBJECT MATTER  
INV. A61B5/00 C12Q1/00 G01N33/00

According to International Patent Classification (IPC) or to both national classification and IPC

B. FIELDS SEARCHED

Minimum documentation searched (classification system followed by classification symbols)  
A61B C12Q G01N

Documentation searched other than minimum documentation to the extent that such documents are included in the fields searched

Electronic data base consulted during the international search (name of data base and, where practical, search terms used)

EPO-Internal

C. DOCUMENTS CONSIDERED TO BE RELEVANT

Category*	Citation of document, with indication, where appropriate, of the relevant passages	Relevant to claim No.
X	WO 2004/113910 A (ROCHE DIAGNOSTICS GMBH [DE]; HOFFMANN LA ROCHE [CH]; SURRIDGE NIGEL AN) 29 December 2004 (2004-12-29)  page 15, line 23 - page 16, line 25 page 22, line 13 - page 23, line 10 page 26, line 10 - page 27, line 10 -----	1-4, 6-8, 10, 11, 14, 16, 24-27, 30, 31, 37
X	US 2003/203498 A1 (NEEL GARY T [US] ET AL NEEL GARY T [US] ET AL) 30 October 2003 (2003-10-30) cited in the application  paragraphs [0036] - [0067] ----- -/--	1-22, 24-43, 46, 51, 52, 56-69, 72, 79-93, 96-117

Further documents are listed in the continuation of Box C.

See patent family annex.

\* Special categories of cited documents :

- \*A\* document defining the general state of the art which is not considered to be of particular relevance
- \*E\* earlier document but published on or after the international filing date
- \*L\* document which may throw doubts on priority claim(s) or which is cited to establish the publication date of another citation or other special reason (as specified)
- \*O\* document referring to an oral disclosure, use, exhibition or other means
- \*P\* document published prior to the international filing date but later than the priority date claimed

- \*T\* later document published after the international filing date or priority date and not in conflict with the application but cited to understand the principle or theory underlying the invention
- \*X\* document of particular relevance: the claimed invention cannot be considered novel or cannot be considered to involve an inventive step when the document is taken alone
- \*Y\* document of particular relevance: the claimed invention cannot be considered to involve an inventive step when the document is combined with one or more other such documents, such combination being obvious to a person skilled in the art.
- \*Z\* document member of the same patent family

Date of the actual completion of the international search

3 December 2007

Date of mailing of the international search report

13/12/2007

Name and mailing address of the ISA/

European Patent Office, P.B. 5818 Patentlaan 2  
NL - 2280 HV Rijswijk  
Tel. (+31-70) 340-2040, Tx. 31 651 epo nl,  
Fax: (+31-70) 340-3016

Authorized officer

Manschot, Jan

## INTERNATIONAL SEARCH REPORT

International application No

PCT/US2007/077236

C(Continuation). DOCUMENTS CONSIDERED TO BE RELEVANT

Category*	Citation of document, with indication, where appropriate, of the relevant passages	Relevant to claim No.
X	US 2002/053523 A1 (LIAMOS CHARLES T [US] ET AL) 9 May 2002 (2002-05-09)  paragraphs [0122], [0143], [0171], [0179]	1-3, 7-17, 22, 24-26, 30-39, 44, 46, 51, 52, 56-65, 70, 96-98, 102-112, 117
X	US 2006/189895 A1 (NEEL GARY T [US] ET AL) 24 August 2006 (2006-08-24)  paragraphs [0096] - [0113]	22, 23, 44, 45, 70, 71, 94, 95
A	WO 00/73785 A (NOVA BIOMEDICAL CORP [US]) 7 December 2000 (2000-12-07)  page 9, line 14 - page 10, line 25 page 12, line 15 - page 15, line 3	1, 7, 8, 14, 15, 30, 31, 37, 38, 45, 56, 57, 63, 64, 71, 79, 80, 86, 87, 95, 109, 110, 118

# INTERNATIONAL SEARCH REPORT

Information on patent family members

International application No

PCT/US2007/077236

Patent document cited in search report	A	Publication date	Patent family member(s)	Publication date			
WO 2004113910	A	29-12-2004	AU 2004250223	A1 29-12-2004			
			BR PI0411695	A 19-09-2006			
			CA 2529300	A1 29-12-2004			
			CA 2529579	A1 10-02-2005			
			CN 1839313	A 27-09-2006			
			EP 1642124	A1 05-04-2006			
			EP 1642125	A1 05-04-2006			
			JP 2007521484	T 02-08-2007			
			JP 2007524818	T 30-08-2007			
			KR 20060022286	A 09-03-2006			
			MX PA05013747	A 08-03-2006			
			WO 2005012900	A1 10-02-2005			
			<hr/>				
			US 2003203498	A1	30-10-2003	US 2005045476	A1 03-03-2005
US 2004104131	A1 03-06-2004						
US 2004094432	A1 20-05-2004						
US 2004094433	A1 20-05-2004						
US 2004099540	A1 27-05-2004						
<hr/>							
US 2002053523	A1	09-05-2002	AT 295538	T 15-05-2005			
			AU 776764	B2 23-09-2004			
			AU 1234701	A 14-05-2001			
			CA 2358993	A1 10-05-2001			
			CN 1322299	A 14-11-2001			
			DE 60020076	D1 16-06-2005			
			DE 60020076	T2 16-03-2006			
			EP 1145000	A1 17-10-2001			
			JP 2003513279	T 08-04-2003			
			JP 2006091022	A 06-04-2006			
			WO 0133216	A1 10-05-2001			
			US 2002084196	A1 04-07-2002			
			US 6616819	B1 09-09-2003			
			<hr/>				
US 2006189895	A1	24-08-2006	NONE				
<hr/>							
WO 0073785	A	07-12-2000	AT 273511	T 15-08-2004			
			AU 5321200	A 18-12-2000			
			CA 2375092	A1 07-12-2000			
			DE 1212609	T1 28-11-2002			
			DE 60012946	D1 16-09-2004			
			DE 60012946	T2 05-01-2005			
			EP 1212609	A2 12-06-2002			
			ES 2177474	T1 16-12-2002			
			JP 2003501627	T 14-01-2003			
			US 6287451	B1 11-09-2001			
			<hr/>				