

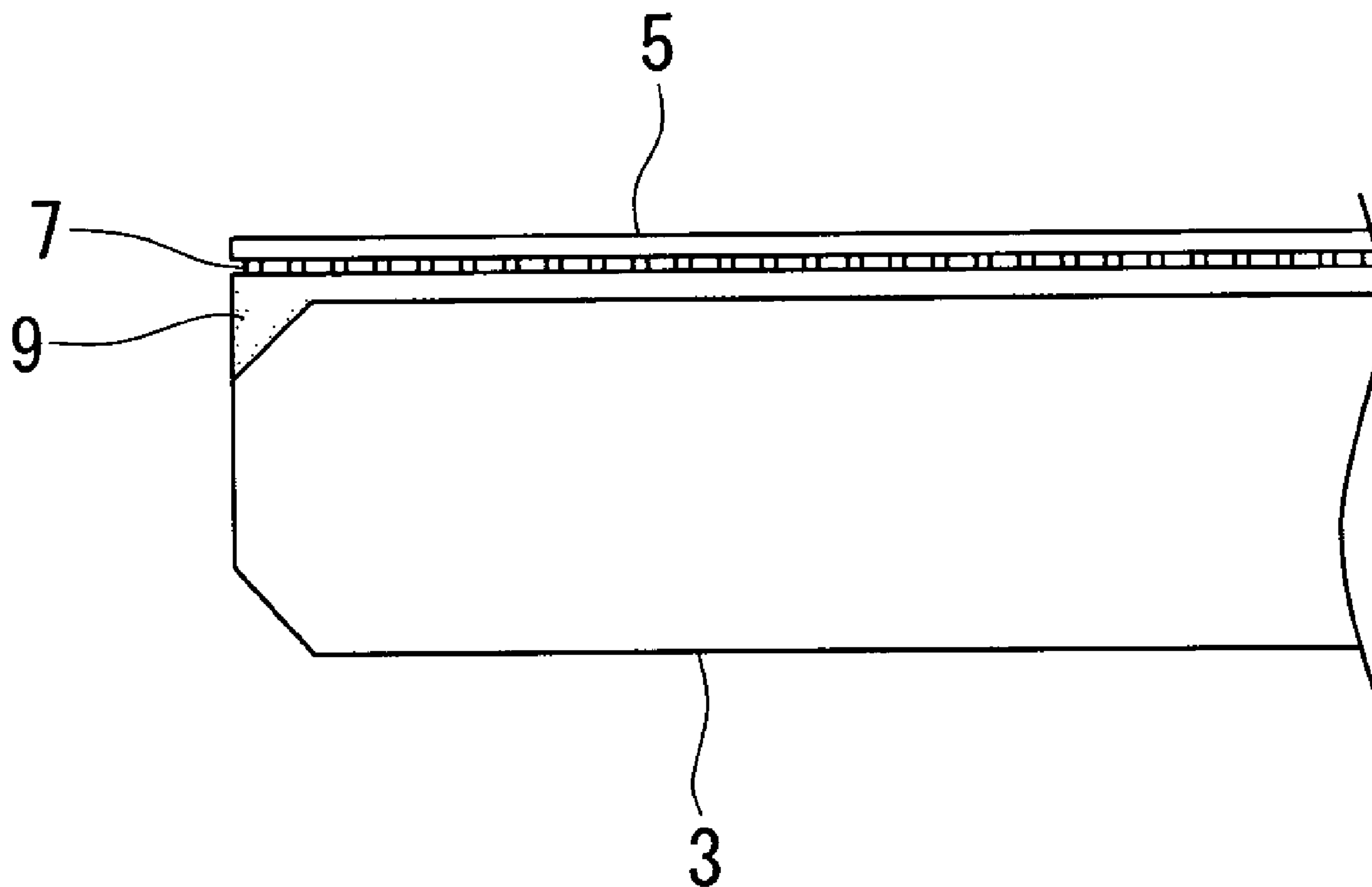

(86) Date de dépôt PCT/PCT Filing Date: 2008/02/18
 (87) Date publication PCT/PCT Publication Date: 2008/08/28
 (45) Date de délivrance/Issue Date: 2012/10/30
 (85) Entrée phase nationale/National Entry: 2009/08/13
 (86) N° demande PCT/PCT Application No.: JP 2008/052676
 (87) N° publication PCT/PCT Publication No.: 2008/102737
 (30) Priorité/Priority: 2007/02/19 (JP2007-037858)

(51) Cl.Int./Int.Cl. *B64C 1/14* (2006.01),
H05K 9/00 (2006.01)
 (72) Inventeurs/Inventors:
OGURI, KAZUYUKI, JP;
OKADA, KATSUTO, JP
 (73) Propriétaires/Owners:
MITSUBISHI HEAVY INDUSTRIES, LTD., JP;
FUJIWARA, CO., LTD., JP
 (74) Agent: SMART & BIGGAR

(54) Titre : ELEMENT DE HUBLLOT D'AVION, SON PROCEDE DE FABRICATION ET ELEMENT DE HUBLLOT D'AVION
 (54) Title: AIRCRAFT WINDOW MEMBER, METHOD OF MANUFACTURING THE SAME, AND AIRCRAFT WINDOW ASSEMBLY



(57) Abrégé/Abstract:

It is possible to provide an aircraft window member having a high durability and an aircraft window assembly. The aircraft window member includes: a film (5) formed from an acrylic resin; a conductive mesh pattern (7) arranged on the film (5), formed from a conductive material so as to have an electromagnetic wave shield property, and having a light transmitting property for assuring a field of view; and a window body (3) formed from an acrylic resin, to which the film (5) having the conductive mesh pattern (7) is attached.



(12) 特許協力条約に基づいて公開された国際出願

(19) 世界知的所有権機関
国際事務局(43) 国際公開日
2008年8月28日 (28.08.2008)

PCT

(10) 国際公開番号
WO 2008/102737 A1

- (51) 国際特許分類:
B64C 1/14 (2006.01) H05K 9/00 (2006.01) 市東山町平橋 2 3 1 3 番地 株式会社フジワラ 春日井工場内 Aichi (JP).
- (21) 国際出願番号: PCT/JP2008/052676 (74) 代理人: 藤田 考晴, 外(FUJITA, Takaharu et al.); 〒2200012 神奈川県横浜市西区みなとみらい 3-3-1 三菱重工横浜ビル 2 4 F Kanagawa (JP).
- (22) 国際出願日: 2008年2月18日 (18.02.2008) (81) 指定国 (表示のない限り、全ての種類の国内保護が可能): AE, AG, AL, AM, AO, AT, AU, AZ, BA, BB, BG, BH, BR, BW, BY, BZ, CA, CH, CN, CO, CR, CU, CZ, DE, DK, DM, DO, DZ, EC, EE, EG, ES, FI, GB, GD, GE, GH, GM, GT, HN, HR, HU, ID, IL, IN, IS, KE, KG, KM, KN, KP, KR, KZ, LA, LC, LK, LR, LS, LT, LU, LY, MA, MD, ME, MG, MK, MN, MW, MX, MY, MZ, NA, NG, NI, NO, NZ, OM, PG, PH, PL, PT, RO, RS, RU, SC, SD, SE, SG, SK, SL, SM, SV, SY, TJ, TM, TN, TR, TT, TZ, UA, UG, US, UZ, VC, VN, ZA, ZM, ZW.
- (25) 国際出願の言語: 日本語 (84) 指定国 (表示のない限り、全ての種類の広域保護が可能): ARIPO (BW, GH, GM, KE, LS, MW, MZ, NA, SD, SL, SZ, TZ, UG, ZM, ZW), ユーラシア (AM, AZ, BY, KG, KZ, MD, RU, TJ, TM), ヨーロッパ (AT, BE, BG, CH, CY, CZ, DE, DK, EE, ES, FI, FR, GB, GR, HR, HU, IE, IS, IT, LT, LU, LV, MC, MT, NL, NO, PL, PT, RO, SE, SI, SK, TR), OAPI (BF, BJ, CF, CG, CI, CM, GA, GN, GQ, GW, ML, MR, NE, SN, TD, TG).
- (26) 国際公開の言語: 日本語
- (30) 優先権データ:
特願2007-037858 2007年2月19日 (19.02.2007) JP
- (71) 出願人 (米国を除く全ての指定国について): 三菱重工業株式会社 (MITSUBISHI HEAVY INDUSTRIES, LTD.) [JP/JP]; 〒1088215 東京都港区港南二丁目 1 6 番 5 号 Tokyo (JP). 株式会社フジワラ (FUJIWARA CO., LTD.) [JP/JP]; 〒4818505 愛知県北名古屋市六ツ師女夫越 1 番地 Aichi (JP).
- (72) 発明者; および
- (75) 発明者/出願人 (米国についてのみ): 小栗 和幸 (OGURI, Kazuyuki) [JP/JP]; 〒4558515 愛知県名古屋市港区大江町 1 0 番地 三菱重工業株式会社 名古屋航空宇宙システム製作所内 Aichi (JP). 岡田 克人 (OKADA, Katsuto) [JP/JP]; 〒4860811 愛知県春日井
- 添付公開書類:
— 国際調査報告書

(54) Title: AIRCRAFT WINDOW MEMBER, ITS MANUFACTURING METHOD, AND AIRCRAFT WINDOW ASSEMBLY

(54) 発明の名称: 航空機用窓材およびその製造方法ならびに航空機用窓組立体

[図2]

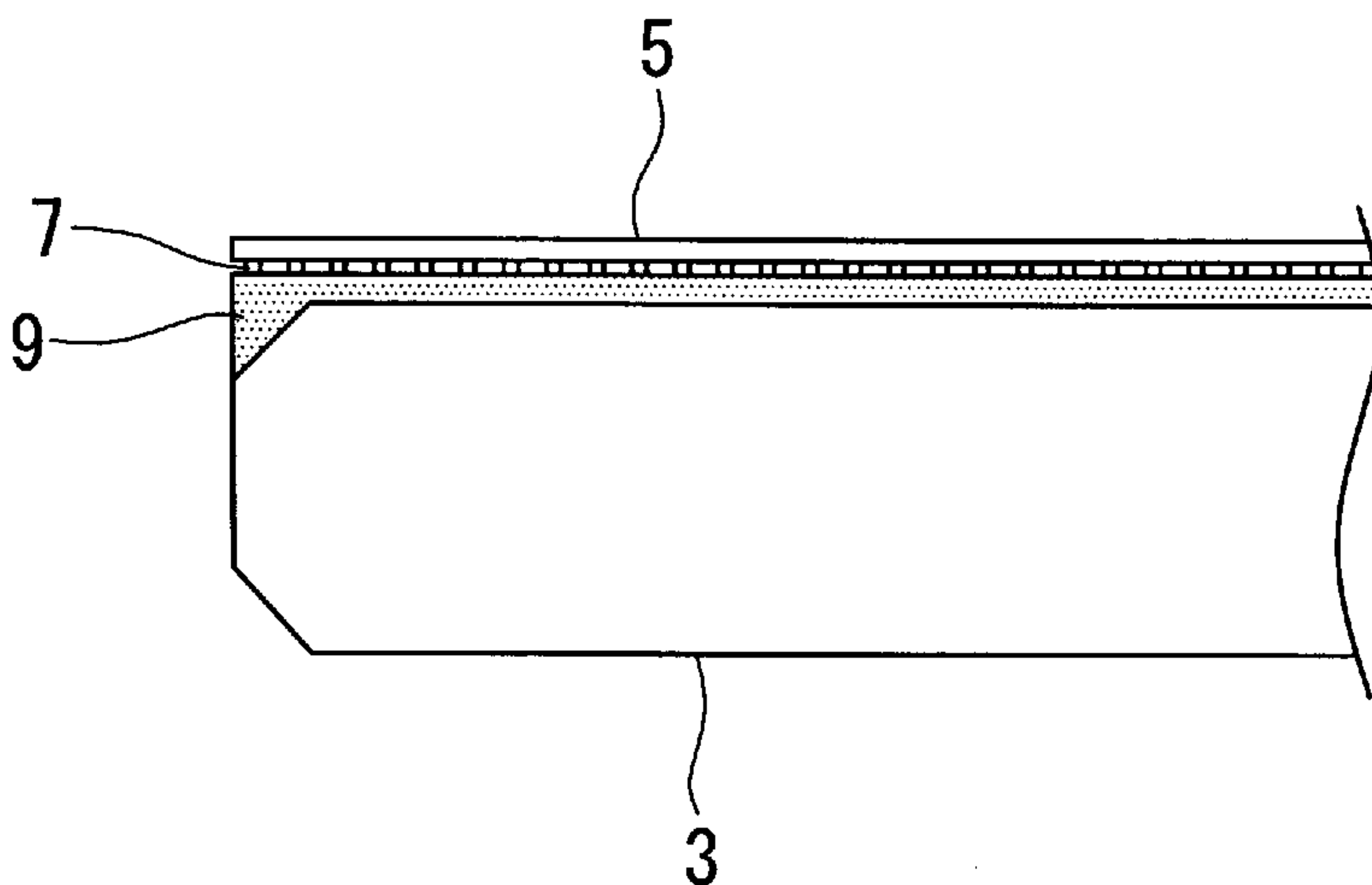

(57) Abstract: It is possible to provide an aircraft window member having a high durability and an aircraft window assembly. The aircraft window member includes: a film (5) formed from an acrylic resin; a conductive mesh pattern (7) arranged on the film (5), formed from a conductive material so as to have an electromagnetic wave shield property, and having a light transmitting property for assuring a field of view; and a window body (3) formed from an acrylic resin, to which the film (5) having the conductive mesh pattern (7) is attached.

(57) 要約: 耐久性に優れた航空機用窓材およびその製造方法ならびに航空機用窓組立体を提供する。航空機用窓材が、アクリル樹脂製とされたフィルム

ム5と、フィルム5上に形成され、視界確保のための光透過性を有しかつ電磁波シールド性を有するように導電性材料がメッシュ形状に形成された導電性メッシュ7と、導電性メッシュ7が形成されたフィルム5が貼付されるアクリル樹脂製の窓本体3とを備える。

WO 2008/102737 A1

DESCRIPTION

AIRCRAFT WINDOW MEMBER, METHOD OF MANUFACTURING THE SAME, AND
AIRCRAFT WINDOW ASSEMBLY

Technical Field

[0001]

The present invention relates to an aircraft window member, a method of manufacturing the same, and an aircraft window assembly.

Background Art

[0002]

In order to ensure visibility outside an aircraft for the crew and passengers in the aircraft, aircraft window members are frequently used for canopies and cabin windows, for example. Endowing such aircraft window members with electromagnetic-wave shielding properties has been examined in order to avoid penetration of harmful electromagnetic waves from the outside of the aircraft or to prevent electromagnetic waves originating in the aircraft from leaking to the outside.

[0003]

A known example of such aircraft window members having electromagnetic-wave shielding properties is described in Patent Document 1. Patent Document 1 discloses a

manufacturing method in which a metal mesh for electromagnetic-wave shielding is formed on a film and is then attached to a window main body.

[0004]

Patent Document 1: Japanese Unexamined Patent Application, Publication No. 2005-104310 (FIG. 5)

Disclosure of Invention

[0005]

However, when polyethylene terephthalate (PET), which is generally used for a resin film, is applied to the above-mentioned aircraft window members, the following problems arise.

Acrylic resin is used for the window main body of each of the aircraft window members, and acrylic resin and PET have a large difference in thermal expansion coefficient. Therefore, when heat treatment is applied after the film is attached to the window main body, wrinkles may occur due to the difference in thermal expansion coefficient. Furthermore, the film may be peeled from the window main body during the operation of the aircraft because of a large temperature difference between when it is on the ground and when it is flying, which is undesirable in terms of durability.

[0006]

The present invention has been made in view of those

circumstances, and an object of the present invention is to provide an aircraft window member excellent in durability, a method of manufacturing the same, and an aircraft window assembly.

[0007]

In order to solve those problems described above, the aircraft window member, the method of manufacturing the same, and the aircraft window assembly of the present invention employ the following solutions.

Specifically, an aircraft window member according to the present invention includes: a film made of acrylic resin; a conductive mesh which is formed on the film and in which a conductive material is formed in a mesh shape so as to have optical transparency for ensuring visibility and to have electromagnetic-wave shielding properties; and a window main body which is made of acrylic resin and to which the film on which the conductive mesh is formed is attached.

[0008]

Since the window main body and the film are made of acrylic resin, they have an equivalent thermal expansion coefficient. Therefore, even when they are heated and cooled during manufacturing, hardly any wrinkles occur. Furthermore, although the aircraft window member is exposed to a large change in temperature during the operation of the aircraft, since there is no difference in thermal expansion coefficient

between the window main body and the film, peeling of the film almost never occurs, thus improving the durability.

[0009]

Further, the aircraft window member according to the present invention may have a configuration in which an adhesive layer is formed between the film on which the conductive mesh is formed and the window main body; and the adhesive layer is made of urethane adhesive.

[0010]

Although polyvinyl butyral (PVB) is generally used as adhesive for laminated glass used in vehicles etc., PVB is not preferable in terms of its adhesive strength with acrylic resin. In contrast, urethane adhesive has sufficient adhesive strength to bond the film made of acrylic resin to the window main body made of acrylic resin. It is preferable that film-like polyurethane be used as the urethane adhesive used in the present invention.

[0011]

Furthermore, according to the aircraft window member of the present invention, the conductive mesh formed on the film may be located between the film and the window main body.

[0012]

Since the conductive mesh formed on the film is located between the film and the window main body, the conductive material of the conductive mesh and the adhesive layer are

brought into direct contact. Urethane adhesive is used as the adhesive layer, and the urethane adhesive does not include plasticizer, unlike PVB. Therefore, a reaction does not occur between the conductive material of the conductive mesh and the adhesive layer, and there is no adverse influence on the optical transparency of the window member.

[0013]

Furthermore, the aircraft window member according to the present invention may have a configuration in which the conductive mesh is located above the window main body with the film therebetween; and a protective layer is formed on the conductive mesh in such a manner as to provide an exposed region used for an electrical connection at an edge portion of the conductive mesh.

[0014]

When the conductive mesh formed on the film does not face the window main body but is located at the side opposite to the window main body with the film therebetween, it is necessary to laminate the protective layer to protect the conductive mesh. If the exposed region which is not covered with the protective layer is provided at the edge portion of the conductive mesh when the protective layer is laminated, it is possible to obtain an electrical connection for electromagnetic-wave shielding by using the exposed region for the electrical connection.

[0015]

Furthermore, an aircraft window assembly according to the present invention includes: any of the aircraft window members described above; and a window frame which holds the aircraft window member.

[0016]

Since any of the aircraft window members described above is included, the aircraft window assembly excellent in durability can be provided.

[0017]

Furthermore, an aircraft-window-member manufacturing method according to the present invention includes attaching a film that is made of acrylic resin and that holds a conductive mesh in which a conductive material is formed in a mesh shape so as to have optical transparency for ensuring visibility and to have electromagnetic-wave shielding properties, to a window main body made of acrylic resin.

[0018]

The aircraft window member can be simply manufactured just by attaching the film to the window main body. Even when the window main body has a curved face, the film can be easily attached thereto because the film has flexibility.

Since the window main body and the film are made of acrylic resin, they have an equivalent thermal expansion coefficient. Therefore, even when they are heated and cooled

during manufacturing, hardly any wrinkles occur. Furthermore, although the aircraft window member is exposed to a large change in temperature during the operation of the aircraft, since there is no difference in the thermal expansion coefficient between the window main body and the film, peeling of the film almost never occurs, thus improving the durability.

[0019]

Furthermore, in the aircraft-window-member manufacturing method according to the present invention, the film may be attached to the window main body after an adhesive layer made of urethane adhesive is provided on the window main body.

[0020]

Although polyvinyl butyral (PVB) is generally used as adhesive for laminated glass used in vehicles etc., PVB is not preferable in terms of its adhesive strength with acrylic resin. In contrast, urethane adhesive has sufficient adhesive strength to bond the film made of acrylic resin to the window main body made of acrylic resin.

[0021]

Furthermore, in the aircraft-window-member manufacturing method according to the present invention, the film may be attached to the window main body so as to locate the conductive mesh between the film and the window main body.

[0022]

Since the conductive mesh formed on the film is located between the film and the window main body, the conductive material of the conductive mesh and the adhesive layer are brought into direct contact. Urethane adhesive is used as the adhesive layer, and the urethane adhesive does not include plasticizer, unlike PVB. Therefore, a reaction does not occur between the conductive material of the conductive mesh and the adhesive layer, and there is no adverse influence on the optical transparency of the window member.

[0023]

Furthermore, the aircraft-window-member manufacturing method according to the present invention may have a configuration in which the film is attached to the window main body so as to locate the conductive mesh above the window main body with the film therebetween; and a protective layer is formed on the conductive mesh in such a manner as to provide an exposed region used for an electrical connection at an edge portion of the conductive mesh.

[0024]

Since the exposed region used for an electrical connection is provided at the edge portion of the conductive mesh, an electrical connection for electromagnetic-wave shielding can be obtained.

[0025]

According to the present invention, the following

51258-21

9

advantages are obtained.

Since the window main body and the film are made of acrylic resin, an aircraft window member having high durability can be provided.

5 Since urethane adhesive is used to bond the film and the window main body, they can be firmly bonded. Even when the adhesive layer and the conductive layer are brought into direct contact, the transmittance for ensuring visibility is not reduced.

10 When the protective layer is laminated on the conductive mesh, the exposed region is provided at the edge portion of the conductive mesh so as to obtain an electrical connection. Therefore, electromagnetic waves can be reliably shielded.

15 According to one aspect of the present invention, there is provided an aircraft window member comprising: a film made of acrylic resin; a conductive mesh which is formed on the film and in which a conductive material is formed in a mesh shape so as to have optical transparency for ensuring visibility and to have electromagnetic-wave shielding properties; and a window main body which is made of acrylic resin and to which the film on which the conductive mesh is formed is attached.

20 According to another aspect of the present invention, there is provided an aircraft-window-member manufacturing method comprising attaching a film that is made of acrylic resin and that holds a conductive mesh in which a conductive material is formed in a mesh shape so as to have optical transparency for ensuring visibility and to have electromagnetic-wave shielding properties, to a window main body made of acrylic resin.

51258-21

9a

Brief Description of Drawings

[0026]

[FIG. 1] FIG. 1 is a perspective view showing an aircraft window member according to a first embodiment of the present invention.

[FIG. 2] FIG. 2 is a partial cross-sectional view showing an edge portion of the aircraft window member shown in FIG. 1.

[FIG. 3] FIG. 3 is a cross-sectional view showing part of a process of manufacturing the aircraft window member shown in FIG. 2.

[FIG. 4] FIG. 4 is a partial cross-sectional view showing an edge portion of an aircraft window member according to a second embodiment of the present invention.

Explanation of Reference Signs:

[0027]

- 1, 1': aircraft window member
- 3: window main body
- 5: film
- 7: conductive mesh
- 9: adhesive layer
- 11: protective layer
- 13: exposed region

Best Mode for Carrying Out the Invention

[0028]

Embodiments of the present invention will be described below with reference to the drawings.

First Embodiment

A first embodiment of the present invention will be described below with reference to FIGS. 1 to 3.

FIG. 1 shows an aircraft window member used for a cabin window, for example. Note that an aircraft window member 1 shown in FIG. 1 is flat, but it may be curved depending on the position at which it is installed.

The aircraft window member 1 includes a window main body 3 serving as a base, a film 5 attached to the window main body 3, and a conductive mesh 7 formed on the film 5. With the conductive mesh 7, the aircraft window member 1 has electromagnetic-wave shielding properties and also has optical transparency to ensure visibility. For example, the transmittance for visible light is about 90%.

[0029]

FIG. 2 is a partial cross-sectional view showing an edge portion of the aircraft window member 1.

As shown in FIG. 2, the film 5 and the conductive mesh 7 are laminated in this order on the window main body 3, with an adhesive layer 9 therebetween.

The window main body 3 is made of acrylic resin, more specifically, polymethyl methacrylate resin (PMMA).

The film 5 is made of acrylic resin, more specifically, polymethyl methacrylate resin (PMMA). In short, the same material as for the window main body 3 is used for the film 5. The thickness of the film 5 is 125 μm , for example.

The conductive mesh 7 is formed in a lattice. A preferable conductive material therefor is metal, and copper is used in this embodiment. The line width of the conductive mesh 7 is about 10 μm , the thickness thereof is about 10 μm , and the pitch thereof is about 300 μm . Such a line width, thickness, and pitch achieve both of electromagnetic-wave

shielding properties and visibility.

The adhesive layer 9 is made of urethane adhesive. Film-like polyurethane is used as the urethane adhesive. After bonding, the adhesive layer 9 flows into the space between the film 5 and the conductive mesh and directly contacts the conductive material (copper) of the conductive mesh 7 to cover the region therearound.

[0030]

Next, a method of manufacturing the aircraft window member 1 having the above-described structure will be described.

First, a copper thin film is laminated on one face of the film 5 by a plating method, for example. The thickness of the copper thin film is 10 μm , for example. Then, a resist film is formed on the surface of the copper thin film. Next, the resist film is exposed to light with a resist pattern and is then developed to form a mesh-shaped mask on the surface of the copper thin film. In this state, the copper is etched by using etchant and then the resist pattern is removed, thereby forming the mesh-shaped conductive mesh 7. In this way, the film 5 having the conductive mesh 7 is obtained as indicated by reference numerals 5 and 7 in FIG. 3.

After the adhesive layer 9, which is made of sheet-like urethane adhesive, is provided on the window main body 3, the film 5 is attached such that the conductive mesh 7 faces the

window main body 3.

Next, heat treatment is applied by using an autoclave, thereby hardening the adhesive layer 9 to fix the film 5 to the window main body 3. The treatment conditions using the autoclave are set as follows: the temperature is 85°C to 95°C, the pressure is 1.03 MPa, and the treatment time is 1 hour.

The aircraft window member 1 is obtained after being taken out from the autoclave and cooled.

The aircraft window member 1, manufactured as described above, is then fitted into a window frame or the like, thereby obtaining an aircraft window assembly.

[0031]

According to the aircraft window member 1 of this embodiment, the following advantages are obtained.

The aircraft window member 1 can be simply manufactured just by attaching the film 5 on which the conductive mesh 7 is formed to the window main body 3. Even when the window main body 3 has a curved face, since the film 5 on which the conductive mesh 7 is formed has flexibility, the film 5 can be easily attached to the window main body 3.

Since the window main body 3 and the film 5 are made of acrylic resin to have an equivalent thermal expansion coefficient, hardly any wrinkles occur on the film 5 even when they are heated by the autoclave during manufacturing and cooled thereafter.

Although the aircraft window member 1 is exposed to a large change in temperature during the operation of the aircraft, since there is no difference in thermal expansion coefficient between the window main body 3 and the film 5, peeling of the film almost never occurs, thus improving the durability.

Since urethane adhesive is used as the adhesive layer 9, it is possible to firmly bond the window main body 3 and the film 5, which are made of acrylic resin.

Since urethane adhesive does not include plasticizer, unlike polyvinyl butyral (PVB), even when it directly contacts the copper of the conductive mesh 7, a reaction does not occur and there is no adverse influence on the optical transparency of the window member.

[0032]

Second Embodiment

Next, a second embodiment of the present invention will be described with reference to FIG. 4.

FIG. 4 is a partial cross-sectional view showing an edge portion of an aircraft window member 1' according to this embodiment.

In this embodiment, unlike the first embodiment, when the film 5 on which the conductive mesh 7 is formed is attached to the window main body 3, the conductive mesh 7 faces upward in FIG. 4, instead of facing the window main body 3. Therefore,

51258-21

15

the window main body 3, the adhesive layer 9, the film 5, and the conductive mesh 7 are laminated in this order from the bottom in FIG. 4. Since the materials and the shapes of the window main body 3, the adhesive layer 9, the film 5, and the conductive mesh 7 are the same as those in the first embodiment, a description thereof will be omitted.

[0033]

A protective layer 11 for protecting the conductive mesh is laminated on the conductive mesh 7. A film made of acrylic resin is used as the protective layer 11. The conductive mesh 7 and the protective layer 11 are bonded by polyvinyl acetate adhesive.

An exposed region 13 which is not covered with the protective layer 11 is provided at an edge portion of the conductive mesh 7. The exposed region 13 is used to obtain an external electrical connection when the aircraft window member 1' is fitted into a window frame to form a window assembly.

[0034]

The aircraft window member 1' having the above-described structure is manufactured as follows.

Since a process of forming the conductive mesh 7 on the film 5 is the same as that in the first embodiment, a description thereof will be omitted.

The protective layer 11 is attached to the conductive mesh 7 formed on the film 5.

The film 5 on which the conductive mesh 7 is formed is attached to the window main body 3. At this time, with regard to the window main body 3 on which the sheet-like adhesive layer 9 is placed, the film 5 is brought into contact with the adhesive layer 9, with the conductive mesh 7 facing upward in FIG. 4 instead of facing the window main body 3.

As in the first embodiment, the adhesive layer 9 is thermally-hardened by the autoclave and cooled, thereby obtaining the aircraft window member 1'.

The aircraft window member 1' thus manufactured is then fitted into a window frame or the like, thereby obtaining an aircraft window assembly.

[0035]

According to the aircraft window member 1' of this embodiment, the following advantages are obtained in addition to the advantages obtained in the first embodiment.

Since the exposed region 13, which is not covered with the protective layer 11, is provided at the edge portion of the conductive mesh 7 when the protective layer 11 is laminated on the conductive mesh 7, the exposed region can be used for an electrical connection. Therefore, when the aircraft window member 1' is fitted into a window frame to form an aircraft window assembly, it is possible to obtain an external electrical connection to reliably shield electromagnetic waves.

[0036]

In each of the embodiments described above, copper is used as the material of the conductive mesh 7. However, the present invention is not limited to the use of copper. For example, gold, silver, aluminum, nickel, titanium, or tin may be used.

CLAIMS

1. An aircraft window member comprising:
 - a film made of acrylic resin;
 - a conductive mesh which is formed on the film and in which a conductive material is formed in a mesh shape so as to have optical transparency for ensuring visibility and to have electromagnetic-wave shielding properties; and
 - a window main body which is made of acrylic resin and to which the film on which the conductive mesh is formed is attached.

2. An aircraft window member according to claim 1, wherein:
 - an adhesive layer is formed between the film on which the conductive mesh is formed and the window main body; and
 - the adhesive layer is made of urethane adhesive.

3. An aircraft window member according to claim 2, wherein the conductive mesh formed on the film is located between the film and the window main body.

4. An aircraft window member according to claim 1 or 2, wherein:
 - the conductive mesh is located above the window main body with the film therebetween; and
 - a protective layer is formed on the conductive mesh in

such a manner as to provide an exposed region used for an electrical connection at an edge portion of the conductive mesh.

5. An aircraft window assembly comprising:

an aircraft window member according to any of claims 1 to 4; and

a window frame which holds the aircraft window member.

6. An aircraft-window-member manufacturing method comprising attaching a film that is made of acrylic resin and that holds a conductive mesh in which a conductive material is formed in a mesh shape so as to have optical transparency for ensuring visibility and to have electromagnetic-wave shielding properties, to a window main body made of acrylic resin.

7. An aircraft-window-member manufacturing method according to claim 6, wherein the film is attached to the window main body after an adhesive layer made of urethane adhesive is provided on the window main body.

8. An aircraft-window-member manufacturing method according to claim 7, wherein the film is attached to the window main body so as to locate the conductive mesh between the film and the window main body.

9. An aircraft-window-member manufacturing method according to claim 6 or 7, wherein:

the film is attached to the window main body so as to locate the conductive mesh above the window main body with the film therebetween; and

a protective layer is formed on the conductive mesh in such a manner as to provide an exposed region used for an electrical connection at an edge portion of the conductive mesh.

**Smart & Biggar
Ottawa, Canada
Patent Agents**

FIG. 1

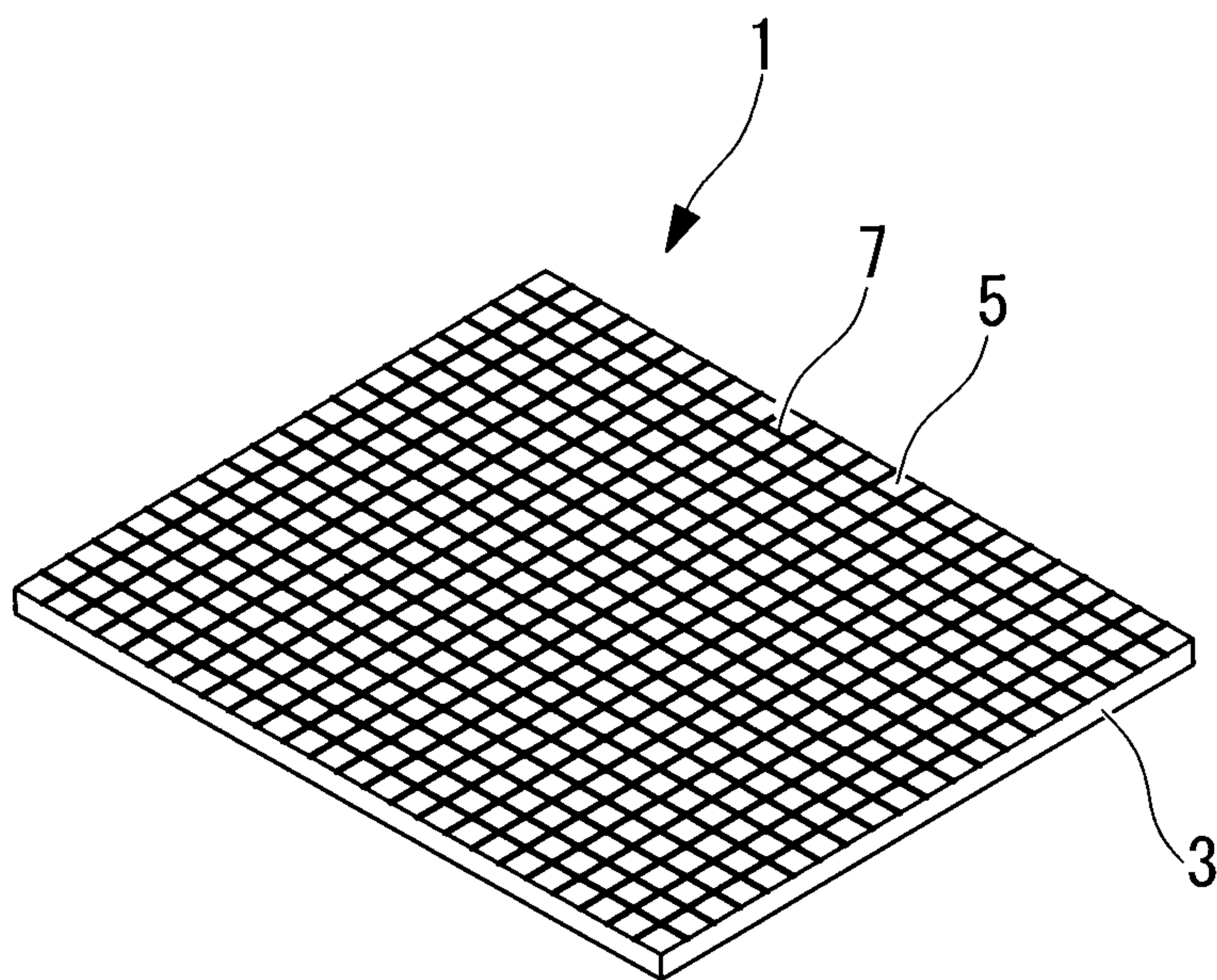

FIG. 2

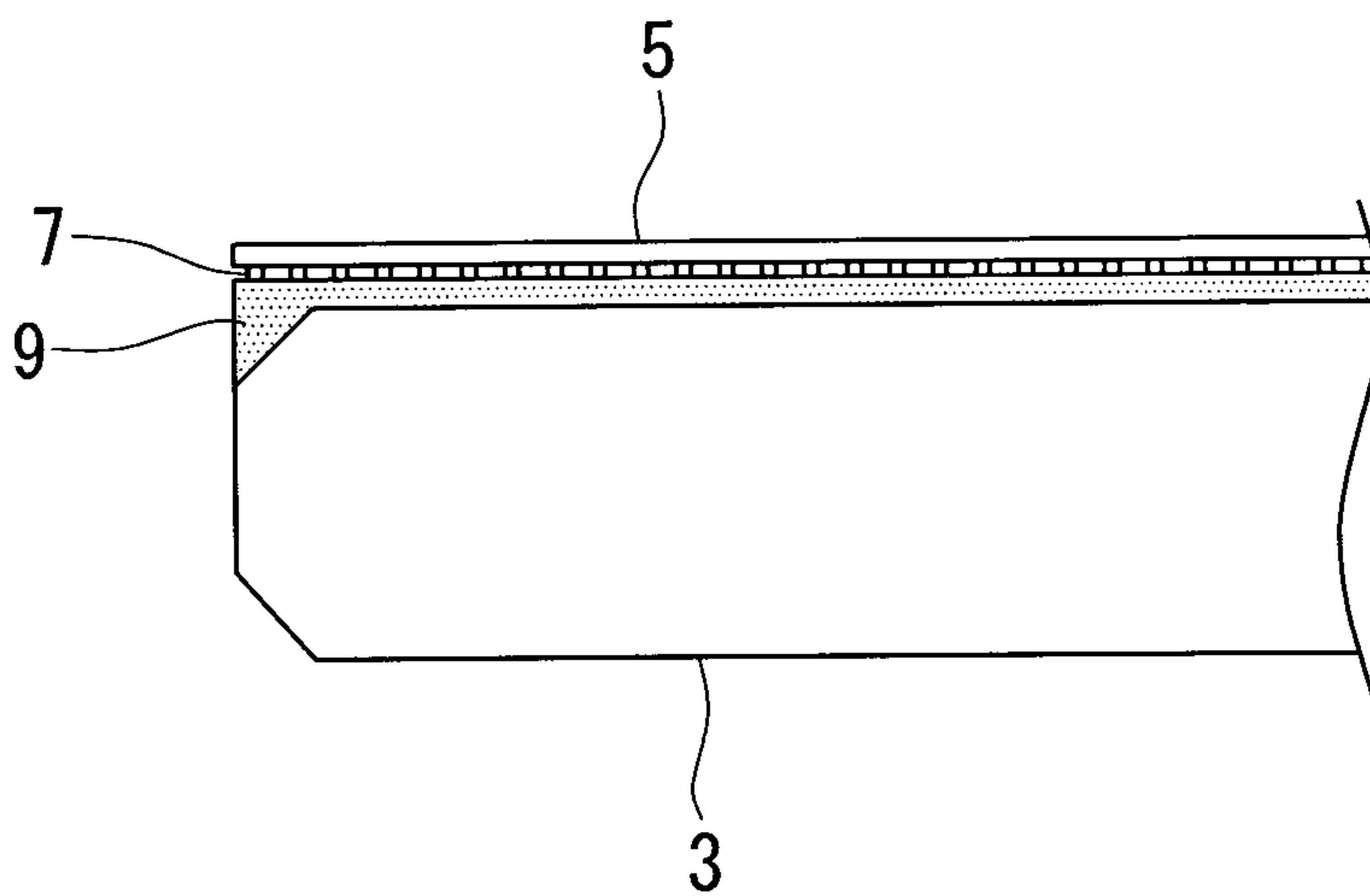

FIG. 3

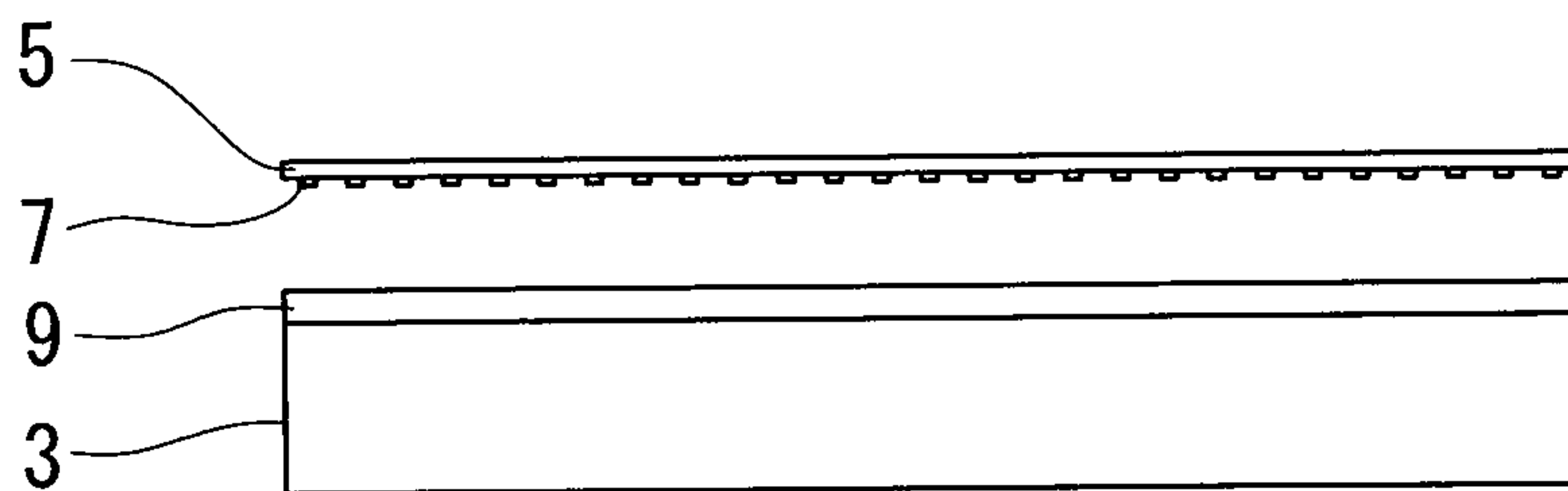

FIG. 4

