



US 20170042316A1

(19) **United States**

(12) **Patent Application Publication**
Schreiber

(10) **Pub. No.: US 2017/0042316 A1**

(43) **Pub. Date: Feb. 16, 2017**

(54) **APPLICATOR FOR COSMETIC PRODUCT, IN PARTICULAR MASCARA, AND METHOD FOR MANUFACTURING SUCH AN APPLICATOR**

Publication Classification

(51) **Int. Cl.**
A46B 3/18 (2006.01)
A46B 9/02 (2006.01)
A45D 40/26 (2006.01)
(52) **U.S. Cl.**
CPC *A46B 3/18* (2013.01); *A45D 40/265* (2013.01); *A46B 9/021* (2013.01); *A46B 9/026* (2013.01); *A46B 2200/1053* (2013.01)

(71) Applicant: **ALBEA SERVICES**, Gennevilliers (FR)

(72) Inventor: **Camille Schreiber**, Paris (FR)

(21) Appl. No.: **15/306,231**

(22) PCT Filed: **Apr. 23, 2015**

(86) PCT No.: **PCT/EP2015/058853**

§ 371 (c)(1),

(2) Date: **Oct. 24, 2016**

(30) **Foreign Application Priority Data**

Apr. 28, 2014 (FR) 1453814

(57) **ABSTRACT**

An applicator for cosmetic product, in particular mascara, has a twisted core (12) and fibres that extend radially from the core (12) in directions substantially orthogonal to said core. The fibres held by the core (12). The fibres form at least one envelope (E) by means of their free end, the envelope extending in a longitudinal extension direction around the core (12), referred to as the main axis X. The envelope (E) has a zone (Z), along the main axis (X), in which the fibres are deflected so as to produce a local deformation (F1-F4) of the envelope.

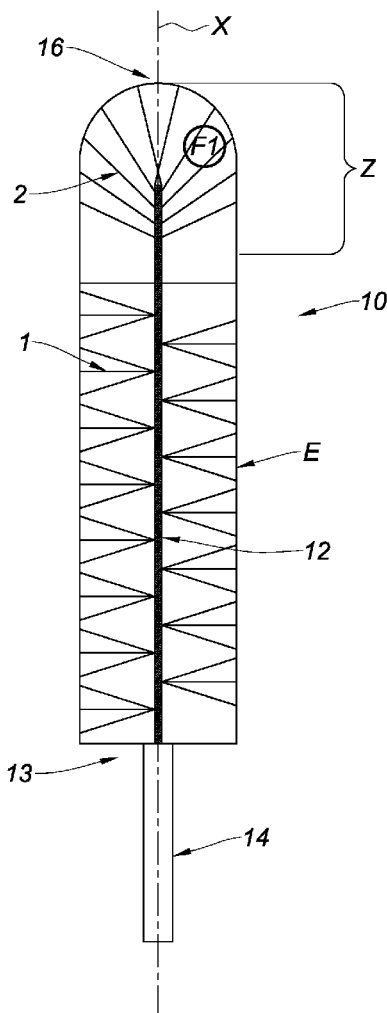

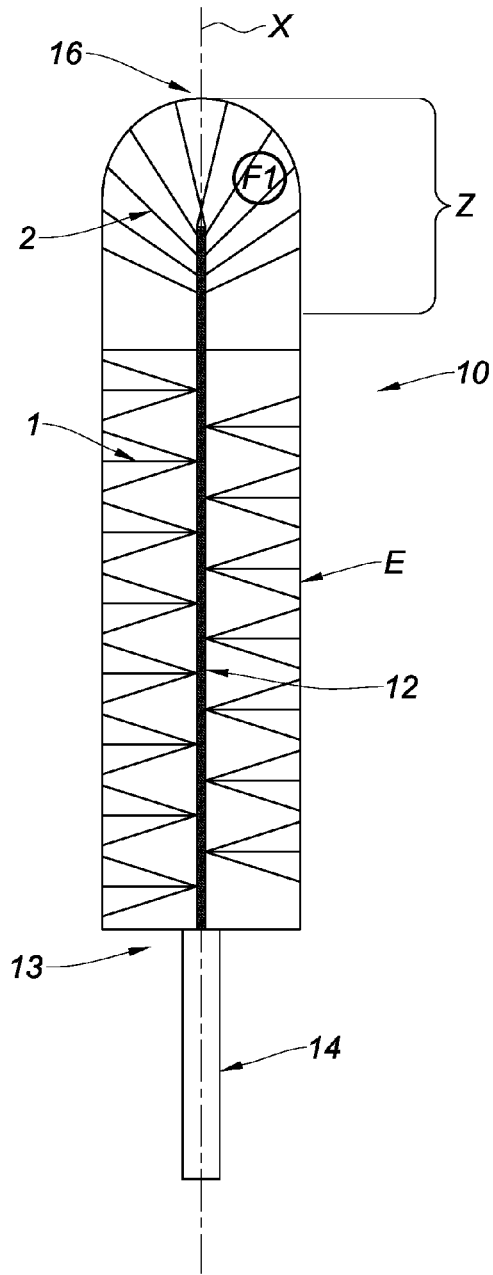

Fig. 1

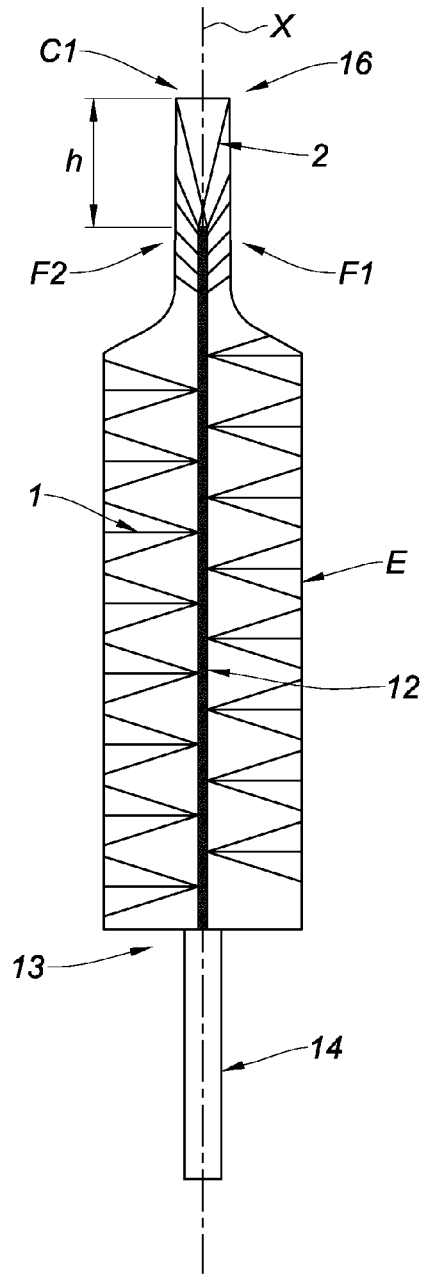

Fig. 2

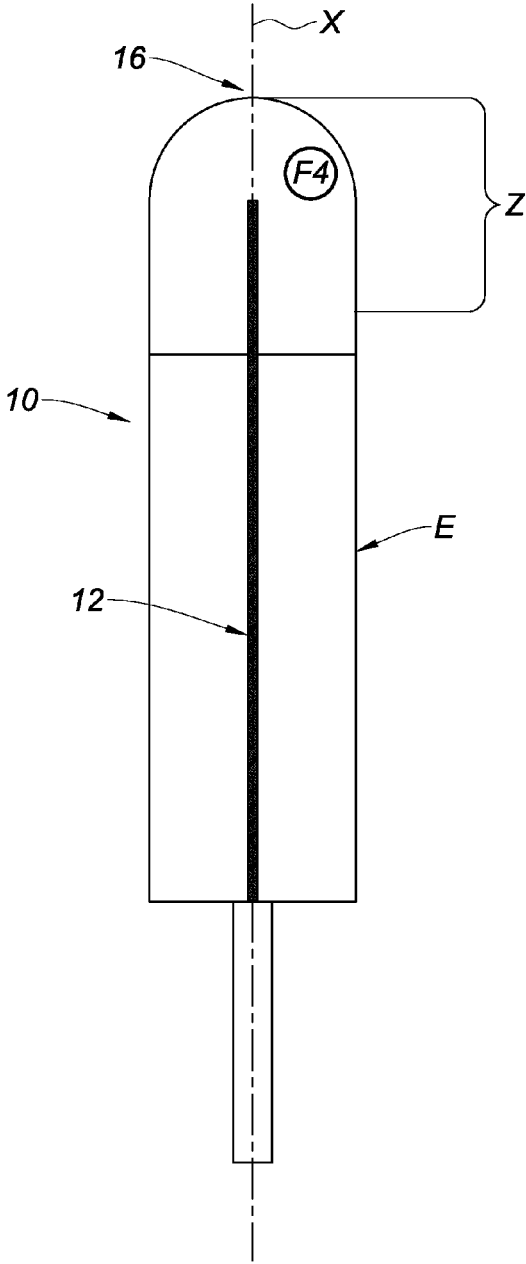

Fig. 3

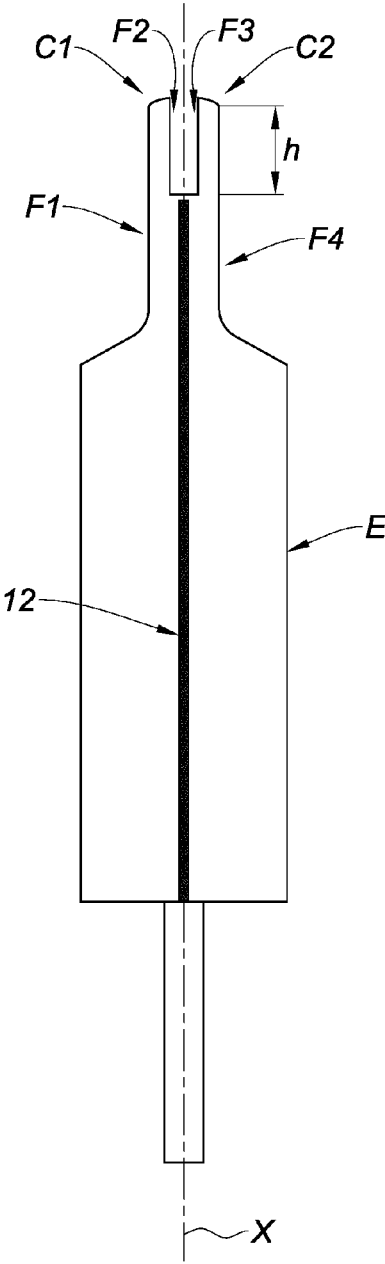

Fig. 4

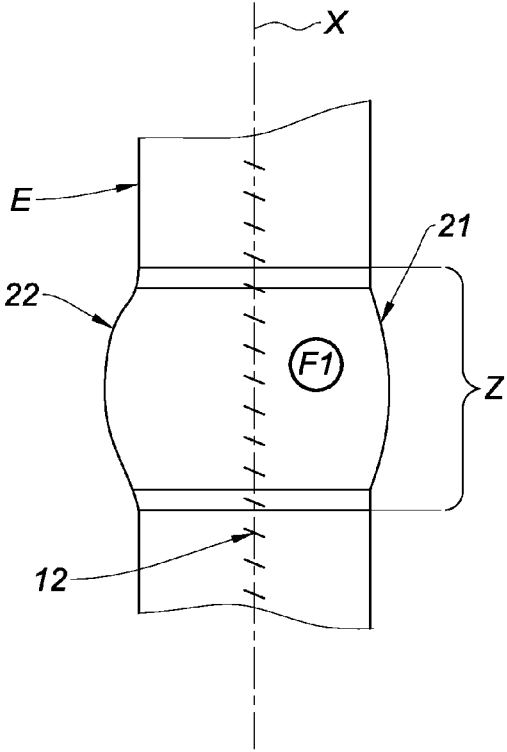

Fig. 5

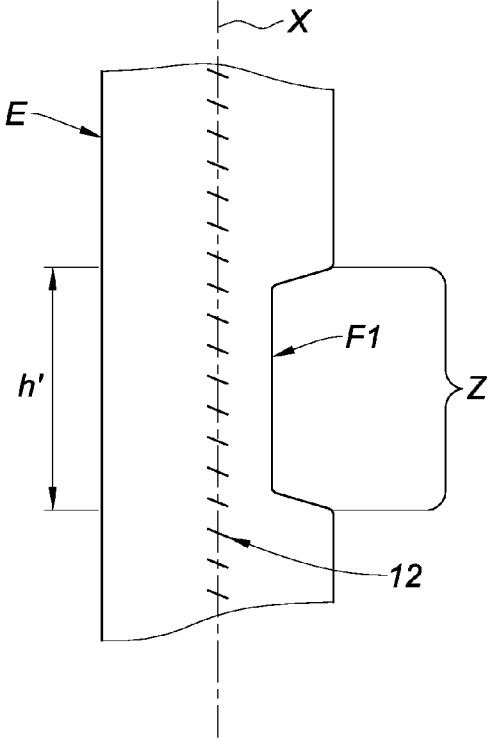

Fig. 6

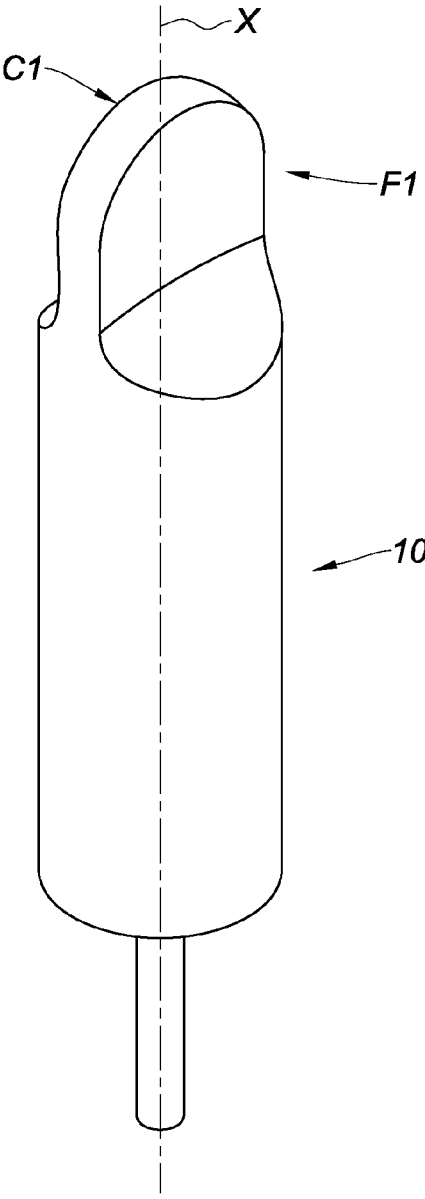

Fig. 7

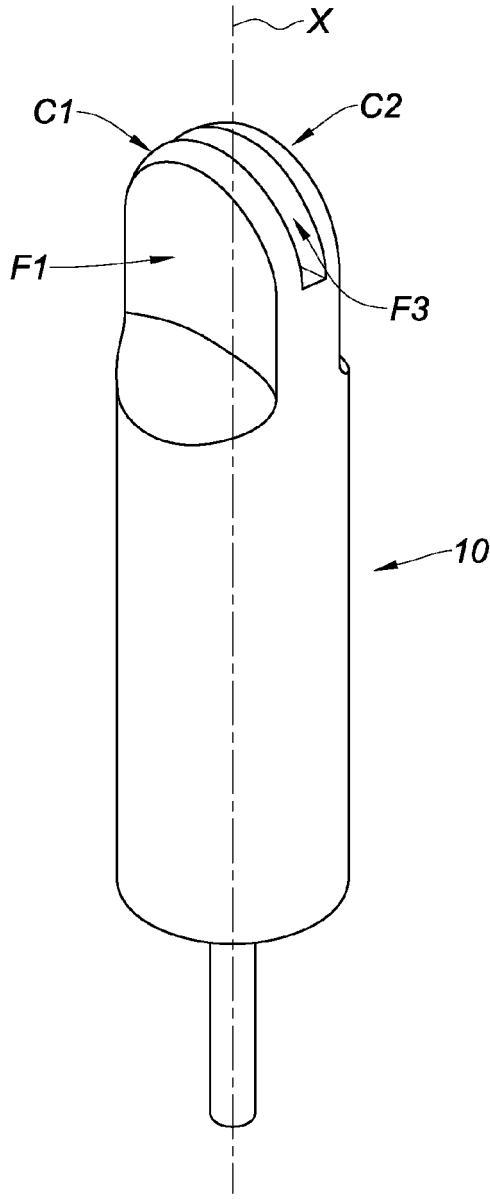

Fig. 8

**APPLICATOR FOR COSMETIC PRODUCT,
IN PARTICULAR MASCARA, AND METHOD
FOR MANUFACTURING SUCH AN
APPLICATOR**

[0001] The invention relates to an applicator for cosmetic product, in particular mascara. The invention also relates to a method for manufacturing such an applicator.

[0002] Mascara applicators can be formed by injection-moulding plastics material; they are then commonly referred to as “plastics brushes”. Plastics brushes are usually injection-moulded. Therefore, plastics brushes can be in original shapes in order to provide particular make-up effects.

[0003] Mascara applicators may also be obtained from fibrous elements held between the longitudinal portions of a twisted metal pin; they are then normally referred to as “twisted brushes”. The ends of said fibrous elements usually form envelopes in a longitudinal extension direction of said brush. The twisted brushes have, due to their method of manufacturing, a cylindrical envelope that offers few options in terms of make-up effects. Many solutions have been proposed in order to give twisted brushes various shapes, but the need for improvement remains.

[0004] The invention proposes producing a twisted brush which has at least one original shape in order to provide a particular make-up effect.

[0005] Therefore, the invention relates to an applicator for cosmetic product, in particular mascara, comprising a twisted core and fibres that extend radially from the core in directions substantially orthogonal to said core, said fibres being held by said core, said fibres forming at least one envelope by means of their free end, said envelope extending in a longitudinal extension direction around said core, referred to as the main axis.

[0006] According to the invention, the envelope has a zone, along said main axis, in which the fibres are deflected so as to produce a local deformation of the envelope.

[0007] In this way, the invention proposes a twisted brush which, by means of its locally deformed envelope or envelopes, makes it possible, as desired, for the user to apply make-up to their eyelids, to highlight the features of their eyes (in the manner of eyeliner), or to load their eyelashes in a particularly effective manner. The twisted brush of the invention therefore has an original shape, which comes from its local deformation or deformations that provide at least one particular make-up effect.

[0008] Since the fibres are simply deflected, the face or faces is/are obtained in a particularly simple manner.

[0009] The use of a twisted brush additionally allows a greater density of fibres than with the bristles of plastics brushes.

[0010] Advantageously, said deflected fibres locally form at least one flattened face of the envelope. “Flattened” means a face which may be flat or substantially flat, in particular a ruled surface having a certain curvature.

[0011] According to various embodiments of the invention, which can be taken together or separately:

[0012] said main axis is rectilinear,

[0013] said core extends along said main axis,

[0014] the core has a distal end and a proximal end, the proximal end being opposite the distal end along the main axis,

[0015] said fibres are distributed along the core, over a substantial part of its length from the distal end, and substantially as far as the proximal end,

[0016] said zone in which the fibres are deflected is located locally along the core,

[0017] the envelope is cylindrical, along all or part of said main axis, apart from said zone in which the fibres are deflected,

[0018] said flattened face or faces has/have greater dimensions compared with the parts of the envelope (E) located in the proximity, in particular transverse dimensions greater than a diameter of the envelope,

[0019] said flattened face is located in the vicinity of the distal end,

[0020] the applicator according to the invention comprises at least two flattened faces arranged to form at least one ridge in the vicinity of the distal end,

[0021] said ridge extends the core from the distal end, mainly in the direction of the main axis,

[0022] the applicator according to the invention comprises two flattened faces arranged to form a reservoir bordered by two ridges that each comprise one of said flattened faces,

[0023] the reservoir is suitable for holding cosmetic product,

[0024] said flattened face is substantially parallel to a plane including the main axis,

[0025] said core consists of a twisted rod,

[0026] said proximal end of the core is extended by a portion of the rod with no fibres,

[0027] the applicator forms a brush.

[0028] The invention also relates to a method for manufacturing an applicator for cosmetic product, in particular mascara, said method comprising:

[0029] a step of positioning a plurality of fibres between longitudinal portions of a pin, then

[0030] a first step of twisting said pin to form a twisted pin having fibres extending radially about said pin, the ends of said fibres forming at least one cylindrical envelope extending in a longitudinal extension direction around said pin, then

[0031] a step of deforming and heating the fibres such that the envelope has, along said main axis, a zone in which the fibres are deflected so as to produce at least one local deformation of the envelope.

[0032] The heating has the objective of retaining the orientation of the fibres which they have been given by the deformation.

[0033] The above-mentioned method advantageously comprises an additional step between said positioning step and said twisting step, said additional step being a step of offsetting the fibres transversely to the longitudinal portions of the pin so as to form groups of fibres, said groups being offset transversely relative to one another along the pin.

[0034] The applicator thus manufactured has the advantage of having a zone in which the fibres are deflected so as to produce a local deformation, while using an operation that remains simple to implement, namely a step of deforming and heating said fibres.

[0035] The invention also relates to a container for cosmetic product, in particular mascara, comprising an applicator as described above.

[0036] The invention will be better understood, and its other aims, details, features and advantages will become clearer in the following detailed explanatory description of at least one embodiment of the invention given as a purely

illustrative and non-limiting example, with reference to the accompanying diagrammatic drawings.

[0037] In these drawings:

[0038] FIG. 1 is a front view of a first embodiment of the applicator according to the invention,

[0039] FIG. 2 is a side view of FIG. 1,

[0040] FIG. 3 is a front view of a second embodiment of the applicator according to the invention,

[0041] FIG. 4 is a side view of FIG. 3,

[0042] FIG. 5 is a partial front view of a third embodiment of the applicator according to the invention,

[0043] FIG. 6 is a side view of FIG. 5,

[0044] FIG. 7 is a slightly inclined isometric view of the first embodiment,

[0045] FIG. 8 is a slightly inclined isometric view of the second embodiment.

[0046] The invention relates to an applicator 10 for cosmetic product, in particular mascara, comprising a twisted core 12. Here, the core 12 is formed by a metal rod or pin, comprising two legs or longitudinal portions that may be interconnected by a curved portion. Said metal rod is, for example, folded in two to form a U shape, the legs of the U then being twisted around one another.

[0047] Fibres 1, 2 extend from the core 12, between a distal end 16 and a proximal end 13 of the core 12. Said fibres 1, 2 are shown only in FIGS. 1 and 2, so as to avoid making the other figures overly complex. The fibres 1, 2 each have a free end and form an envelope E by means of said ends.

[0048] FIGS. 1 to 8 show, in particular, three embodiments of applicators according to the invention. The impression of the envelope E will of course be more or less pronounced depending on the density of the fibres.

[0049] The applicator 10 extends in a main longitudinal extension direction, or main axis, which is provided with reference sign X in FIGS. 1 to 8. This axis X is also advantageously the axis of the core 12. The core 12 is rectilinear in this case. In a variant, the core may have a curvature between the distal end 16 and the proximal end 13.

[0050] According to the invention, as shown in FIGS. 1 to 6, the envelope E has, along said main axis X, a zone Z in which the fibres 2 are deflected such that the envelope E locally has a local deformation F1-F4.

[0051] In other words, the fibres 1 extend from the core 12, in an organised manner, radially and orthogonally relative to said core 12, except in the zone Z, in the region of which they are disorganised, or in which the fibres 2 are oriented in different directions relative to one another by being deflected in the direction of the core 12. In other words again, the fibres do not extend radially from the core 12 in said zone Z. Outside the zone Z, the fibres 1 form in particular a substantially cylindrical envelope E along the main axis X.

[0052] The presence of deflected fibres 2, at least locally, has the advantage of providing a zone Z which has many points of contact with a user's eyelashes. Therefore, in the zone Z, the applicator 10 allows the eyelashes to be loaded with more product. In fact, when the fibres only extend radially from the core 12, they are organised in the same direction and only provide a limited number of points of contact with the user's eyelashes.

[0053] Furthermore, said zone Z gives the eyelashes the impression of volume.

[0054] The first embodiment, shown in FIGS. 1, 2 and 7, shows an applicator 10 according to the invention which comprises two flattened faces F1, F2 arranged to form a ridge C1 in the vicinity of the distal end 16. FIGS. 1 and 2 show the applicator 10, which extends along the axis X towards the proximal end 13. Said proximal end 13 is opposite the distal end 16 along said axis X.

[0055] FIGS. 1, 2 and 7 show the face F1 of the envelope E; said face F1 is located in the zone Z. FIG. 2 makes it clear that the end of the twisted metal rod 12 is extended, over a height h, by fibres which extend from the core 12 in the direction of the main axis X. Said height h does not include a rod portion, and is solely made up of fibres. This has the advantage of preventing the user from injuring themselves with the end of the twisted metal rod forming the core 12.

[0056] In addition, the ridge thus formed makes it possible to outline the contours of the user's eyes.

[0057] Another advantage is the option of using one of the flattened faces F1, F2, forming the ridge C1, to apply make-up to the user's eyelids.

[0058] The applicator 10 according to this first embodiment is also particularly suitable to applying make-up to the corners of the user's eyes, since it makes it possible to reach areas that are inaccessible using a solely cylindrical envelope E.

[0059] The second embodiment, shown in FIGS. 3, 4 and 8, shows an applicator 10 according to the invention which comprises four flattened faces F1-F4 arranged to form two ridges C1, C2 in the vicinity of the distal end 16.

[0060] FIG. 3 shows the flattened face F4 of the envelope E; said face F4 is located in the zone Z. FIG. 4 makes it clear that the end of the twisted metal rod is extended, over a height h, by fibres which extend from the core 12 in the direction of the main axis X. FIG. 4 also allows it to be noted that the applicator 10 comprises two flattened faces F2, F3 arranged to form a reservoir. Said reservoir is bordered by the two ridges C1, C2.

[0061] Like the applicator 10 according to the first embodiment, the second embodiment has the advantage of preventing the user from injuring themselves with the end of the twisted metal rod forming the core 12, since said height h does not include a rod portion, and is solely made up of fibres. It also has the advantage of it being possible to use one of the flattened faces F1, F4 that do not form the reservoir to apply make-up to the user's eyelids (see FIG. 8).

[0062] Furthermore, the applicator 10 according to the second embodiment is particularly advantageous for consistently loading the user's eyelashes, in particular locally, since its reservoir is capable of holding an increased quantity of cosmetic product in order to then release said product to points that are difficult for applicators having solely cylindrical envelopes E to access.

[0063] The third embodiment, shown in FIGS. 5 and 6, shows an applicator 10 that has at least one flattened face F1, along the main axis X, between its distal end 16 and proximal end 13. FIGS. 5 and 6 are partial views that do not show said ends 13, 16.

[0064] The flattened face F1 is delimited by lateral edges 21, 22, as shown in FIG. 5. Said edges 21, 22 have the advantage of catching hold of the user's eyelashes and therefore of assisting with lengthening said eyelashes. Said flattened face F1 preferably extends over a height h' along the main axis X.

[0065] In addition, the applicator **10** in this embodiment may advantageously have a plurality of flattened faces **F1** along the main axis **X**, around the entirety of the envelope **E** (an alternative that is not shown here). The flattened face or faces **F1** are substantially in parallel with a plane including the main axis. Therefore, the zone or zones **Z** that include one of said flattened faces **F1** are zones in contact with which the eyelashes are loaded in a consistent manner.

[0066] Alternatively, the flattened faces **F1, F2, F3, F4**, when viewed from the front, have dimensions in a plane orthogonal to the core that are greater than the diameter of the cylinder formed by the envelope **E** outside the zone or zones **Z**. In other words, in the region of the zone or zones **Z**, the envelope formed by the applicator is enlarged. This alternative is compatible with the three embodiments that have just been described. This alternative makes it possible to delimit the zone **Z**, in particular relative to the envelope **E**, in order to make it particularly visible to the user.

[0067] The invention also relates to a method for producing an applicator **10** for cosmetic product, in particular mascara, for example that which has just been described.

[0068] This method first includes a step of positioning a plurality of fibres between longitudinal portions of a pin (not shown). The fibres are distributed in such a way that said longitudinal portions pass substantially through the middle of each of said fibres.

[0069] The following step of said method is a first step of twisting said pin to form a twisted pin having fibres extending radially about said pin. The ends of said fibres thus form at least one cylindrical envelope **E** extending in a longitudinal extension direction **X** about said pin. The fibres are distributed in the form of helices of fibres as a result of the twisting of the pin.

[0070] The following step is a step of deforming and heating the fibres such that the envelope **E** has, along said main axis **X**, a zone **Z** in which the fibres are deflected so as to produce at least one local deformation of the envelope **E**.

[0071] Owing to the heating, the shape memory of the fibres disappears, and said fibres retain the orientation provided by the deformation.

[0072] It should be noted that this deformation does not originate from the twisting step or from an additional twisting step that would be localised in the zone in which the fibres are deflected. Said deformation is made in the region of the fibres themselves. The fibres are deformed by any known means, for example by heating (non-limiting example).

[0073] Advantageously, the method described above may include an additional step (alternative not shown here, alternative that can be combined with all the above-described embodiments). This additional step is between said positioning step and said twisting step. It involves offsetting the fibres transversely to the longitudinal portions of the pin so as to form groups of fibres, said groups being offset transversely relative to one another along the pin.

[0074] After the twisting step, a brush is thus obtained that has fibres extending radially about said brush, the ends of said fibres thus forming two interlocking cylindrical envelopes around said pin, having a first envelope having a radial extension that is less than that of the second envelope.

[0075] Advantageously, the above-described method and its alternative again comprise an additional step of which the result is not shown here, but which is applicable to all the embodiments set out above. This is a step which follows the

step of deforming and heating the fibres. During this step, the fibres **1** forming the cylindrical envelope or envelopes **E** undergo a cutting process. Therefore, the zone or zones **Z** having deflected fibres **2** have greater dimensions compared with the parts of the envelope **E** located in the proximity, in particular transverse dimensions that are greater than a diameter of the envelope **E**.

[0076] Advantageously, a portion of the pin **14** that does not comprise any fibres and extends the proximal end **13** is intended to be attached to the inside of a hollow rod, which is in turn connected to a sleeve, using which the user handles said applicator **10** (the rod and the sleeve are not shown here). This portion **14** is either twisted or not twisted.

[0077] It should be noted that the applicator **10** of the invention advantageously forms a brush.

[0078] It should also be noted that the embodiments shown in FIGS. **1** to **8** can advantageously be combined in order to combine the make-up effects, or even in order to obtain new ones. It is in particular possible to provide a plurality of zones **Z** in which the fibres are deflected, in particular an end zone **Z** and one or more zones **Z** along said main axis that are at a distance from one another. The envelope or envelopes **E** may advantageously retain their cylindrical shapes between said zones **Z**.

[0079] The fibres are advantageously made of plastics material, of the polyamide type, such as "nylon". Alternatively, the fibres are advantageously made of polyester, since they are softer to the touch for the user.

[0080] It should be noted that the above-described zone or zones **Z** are not obtained by a cutting step (shearing or milling), but solely by deforming and heating the fibres.

1. Applicator for cosmetic product, in particular mascara, comprising a twisted core and fibres that extend radially from the core in directions substantially orthogonal to said core, said fibres being held by said core, said fibres forming at least one envelope (**E**) by means of their free end, said envelope extending in a longitudinal extension direction around said core (**12**), referred to as the main axis (**X**), characterised in that the envelope (**E**) has a zone (**Z**), along said main axis (**X**), in which the fibres are deflected so as to produce a local deformation (**F1-F4**) of the envelope.

2. Applicator according to claim 1, wherein said deflected fibres locally form at least one flattened face (**F1, F2, F3, F4**) of the envelope (**E**).

3. Applicator according to claim 2, wherein the flattened face or faces (**F1, F2, F3, F4**) has/have greater dimensions compared with the parts of the envelope (**E**) located in the proximity.

4. Applicator according to claim 2, wherein the core has a distal end and a proximal end, the proximal end being opposite the distal end along the main axis (**X**), said flattened face (**F1**) being located in the vicinity of the distal end.

5. Applicator according to claim 4, comprising at least two flattened faces (**F1, F2**) arranged to form at least one ridge (**C1**) in the vicinity of the distal end.

6. Applicator according to claim 5, wherein said ridge (**C1**) extends the core from the distal end.

7. Applicator according to claim 4, comprising two flattened faces (**F2, F3**) arranged to form a reservoir bordered by two ridges (**C1, C2**) that each comprise one of said flattened faces (**F2, F3**).

8. Applicator according to claim 1, wherein the reservoir is suitable for holding cosmetic product.

9. Applicator according to claim **2**, wherein said flattened face (F1) is substantially parallel to a plane including the main axis (X).

10. Method for manufacturing an applicator for cosmetic product, in particular mascara, said method comprising:

a step of positioning a plurality of fibres between longitudinal portions of a pin, then

a step of twisting said pin to form a twisted pin having fibres extending radially about said pin, the ends of said fibres forming at least one cylindrical envelope (E) extending in a longitudinal extension direction around said pin, referred to as the main axis (X), then

a step of deforming and heating the fibres such that the envelope (E) has, along said main axis (X), a zone (Z) in which the fibres are deflected so as to produce at least one local deformation of the envelope (E).

11. Method according to claim **10**, comprising an additional step between said positioning step and said twisting step, said additional step being a step of offsetting the fibres transversely to the longitudinal portions of the pin so as to form groups of fibres, said groups being offset transversely relative to one another along the pin.

12. Applicator for cosmetic product, in particular for mascara, obtained using the method according to claim **10**.

13. Container for cosmetic product, in particular mascara, comprising an applicator according to claim **1**.

* * * * *