



US 20060035665A1

(19) **United States**

(12) **Patent Application Publication**

Young et al.

(10) **Pub. No.: US 2006/0035665 A1**

(43) **Pub. Date: Feb. 16, 2006**

(54) **ELECTROSTATIC OVERVOLTAGE PROTECTION DEVICE**

(60) Provisional application No. 60/120,639, filed on Feb. 18, 1999.

(76) Inventors: **Michael F. Young**, McLean, VA (US);
Hunter Jones, Silver Spring, MD (US);
John Casar, McLean, VA (US); **Paul Akimov**, Springfield, VA (US)

Publication Classification

(51) **Int. Cl.**
H04M 1/00 (2006.01)
(52) **U.S. Cl.** **455/550.1**

Correspondence Address:
Herman Hohaus
6212 Berlee Drive
Alexandria, VA 22312 (US)

(57) **ABSTRACT**

An electrostatic overvoltage protection device for use in remotely mountable weatherproof bi-directional, half-duplex switching amplifier system designed to provide maximum range for low power half-duplex radios such as Spread Spectrum radio transceivers in which a conductor is connected between the signal input and a source of reference potential having a length selected to be one quarter of the wavelength of a preselected desired signal band frequency and is one of a trace on a circuit board and wire.

(21) Appl. No.: **11/224,001**
(22) Filed: **Sep. 13, 2005**

Related U.S. Application Data

(62) Division of application No. 09/505,201, filed on Feb. 16, 2000, now Pat. No. 6,957,047.

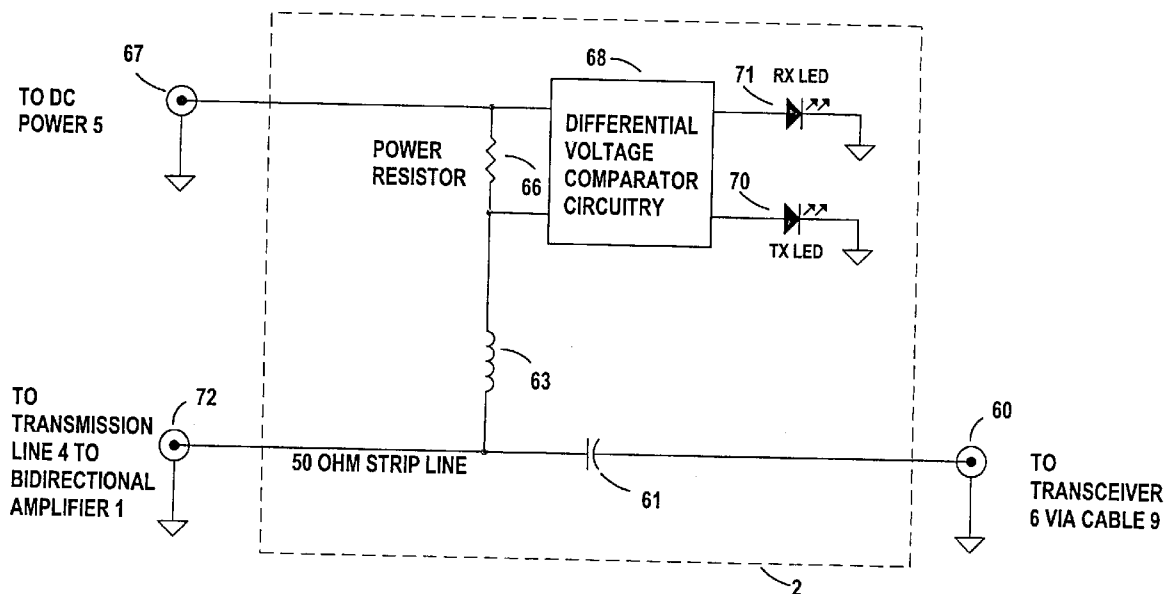

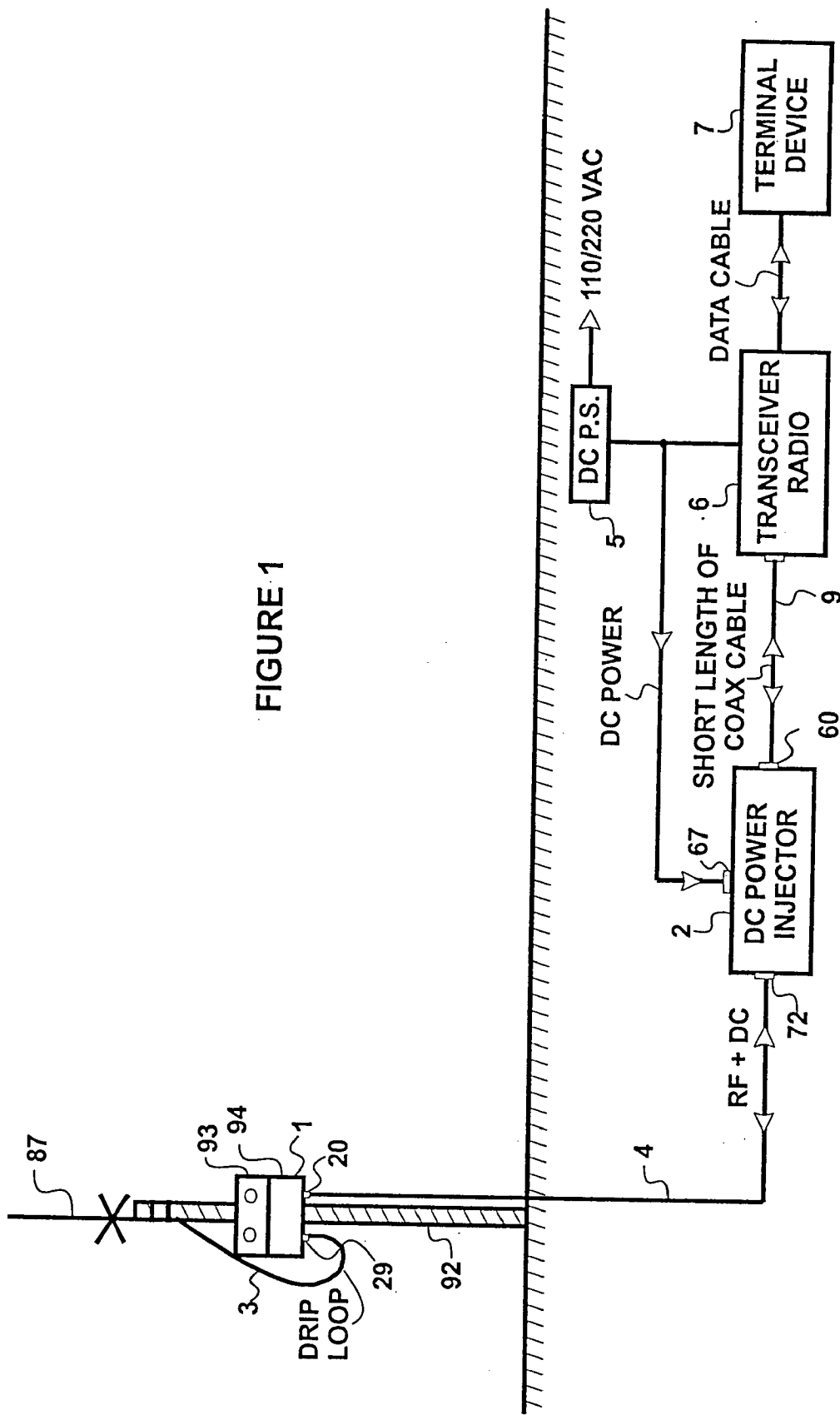

FIGURE 1

FIGURE 2

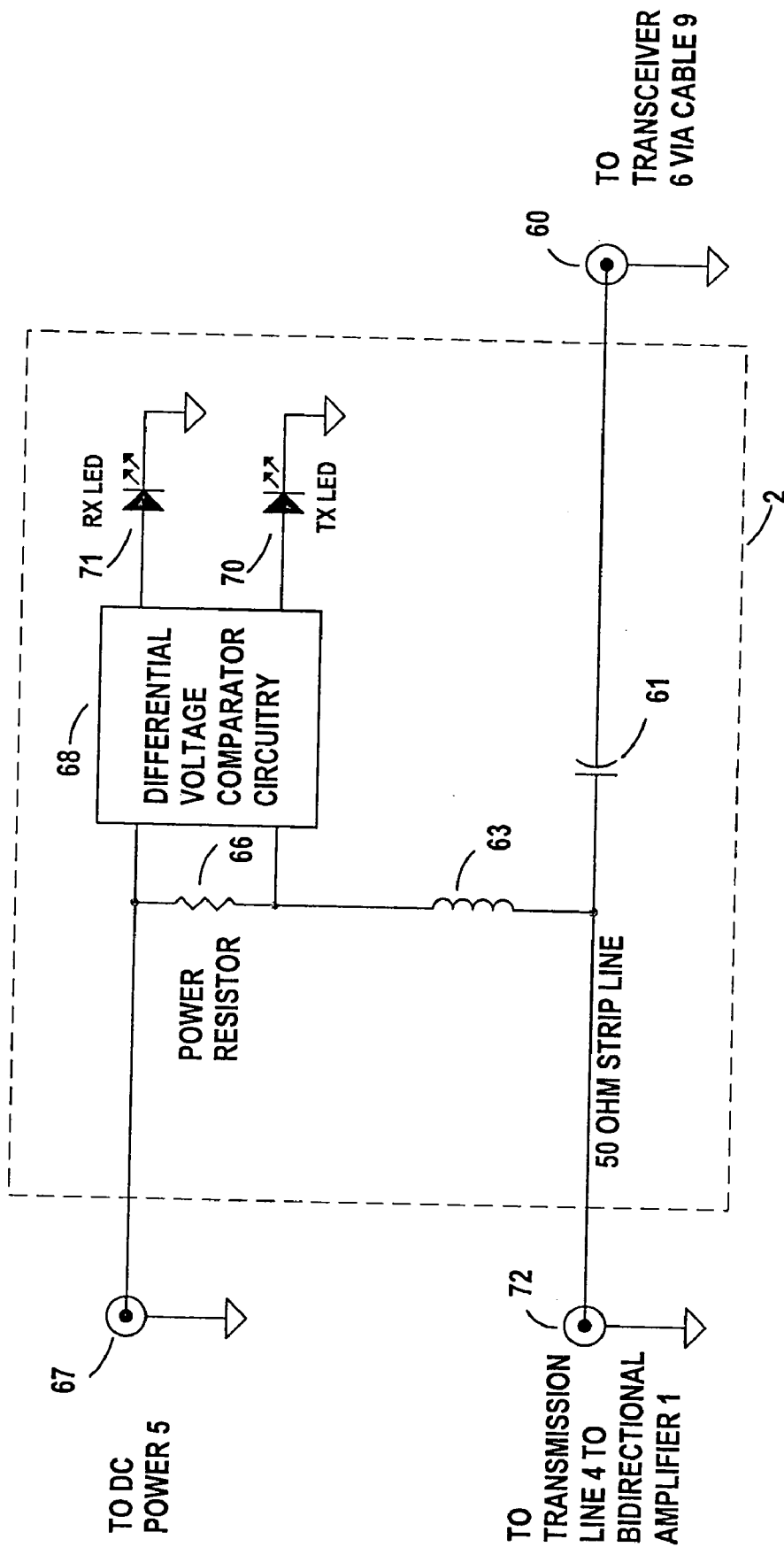
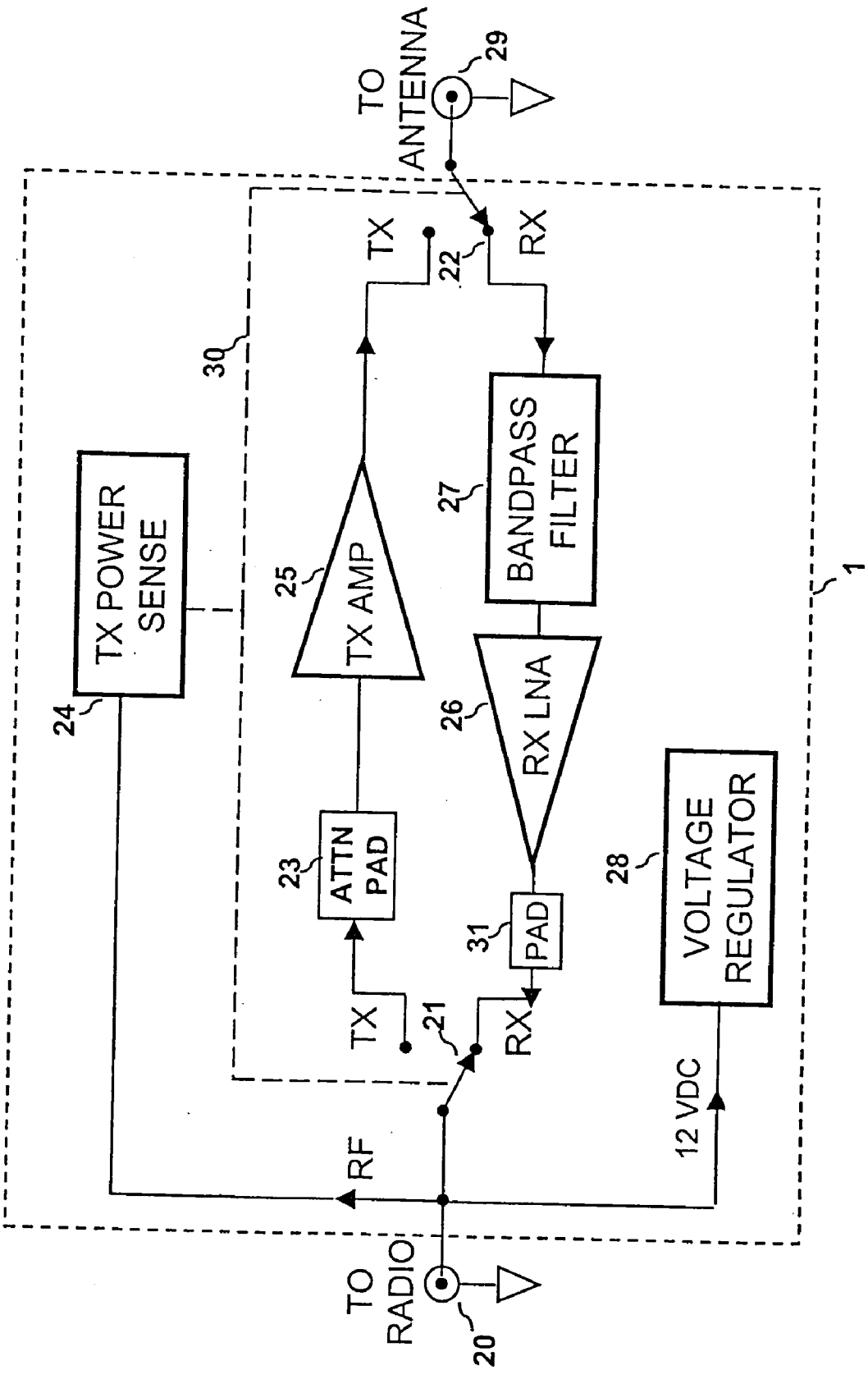

FIGURE 3



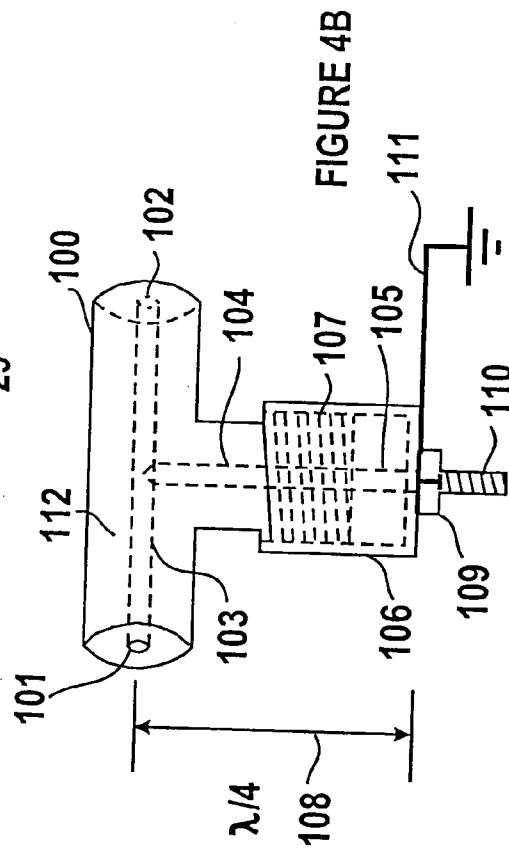
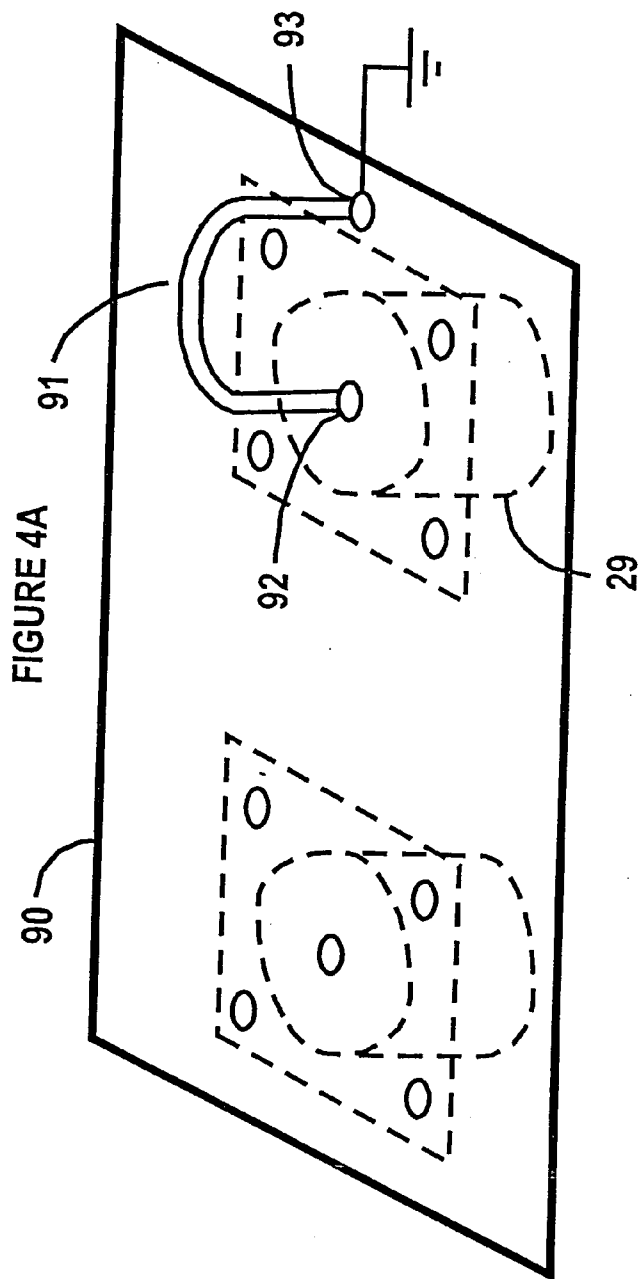

FIGURE 5

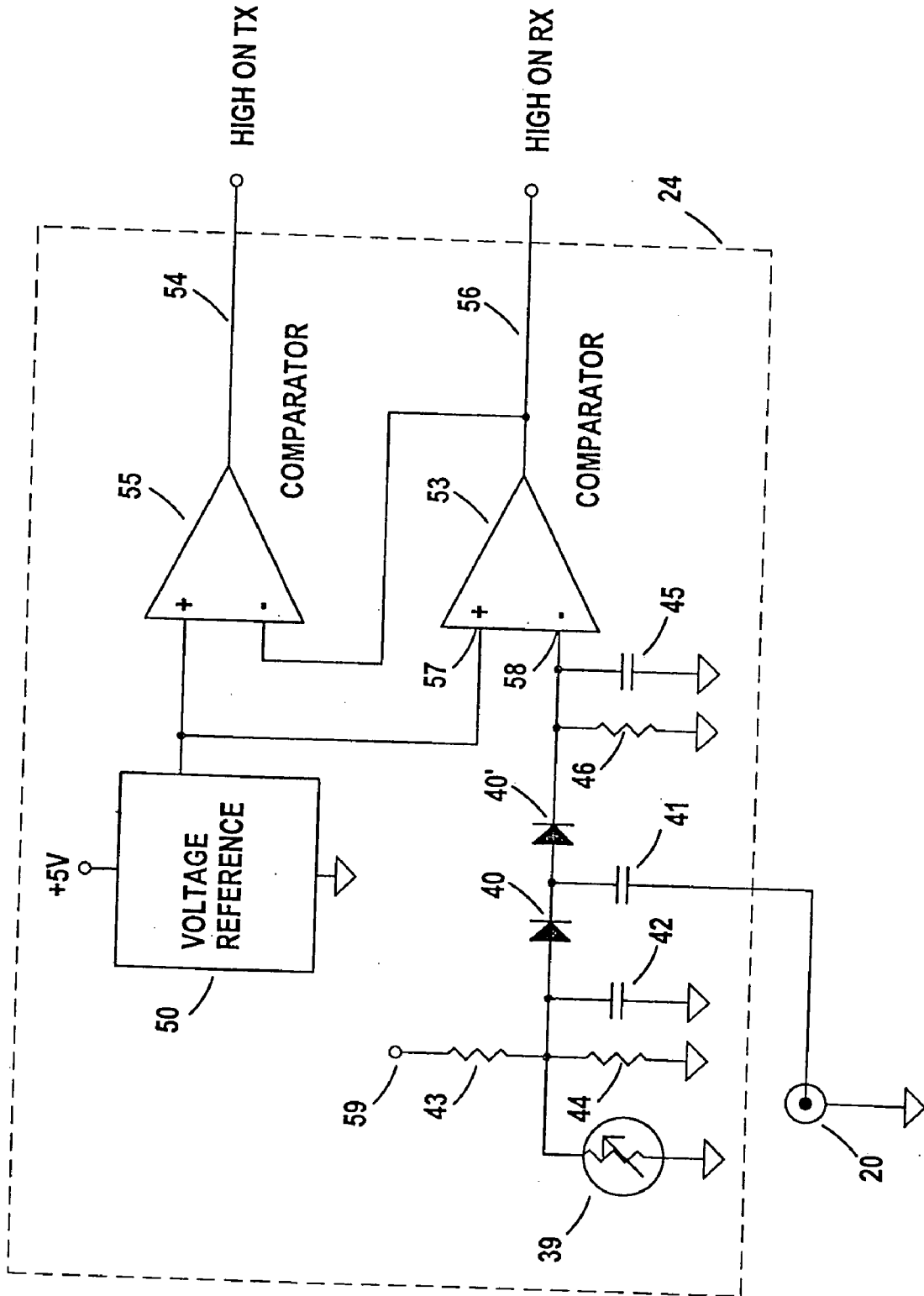

FIGURE 6A

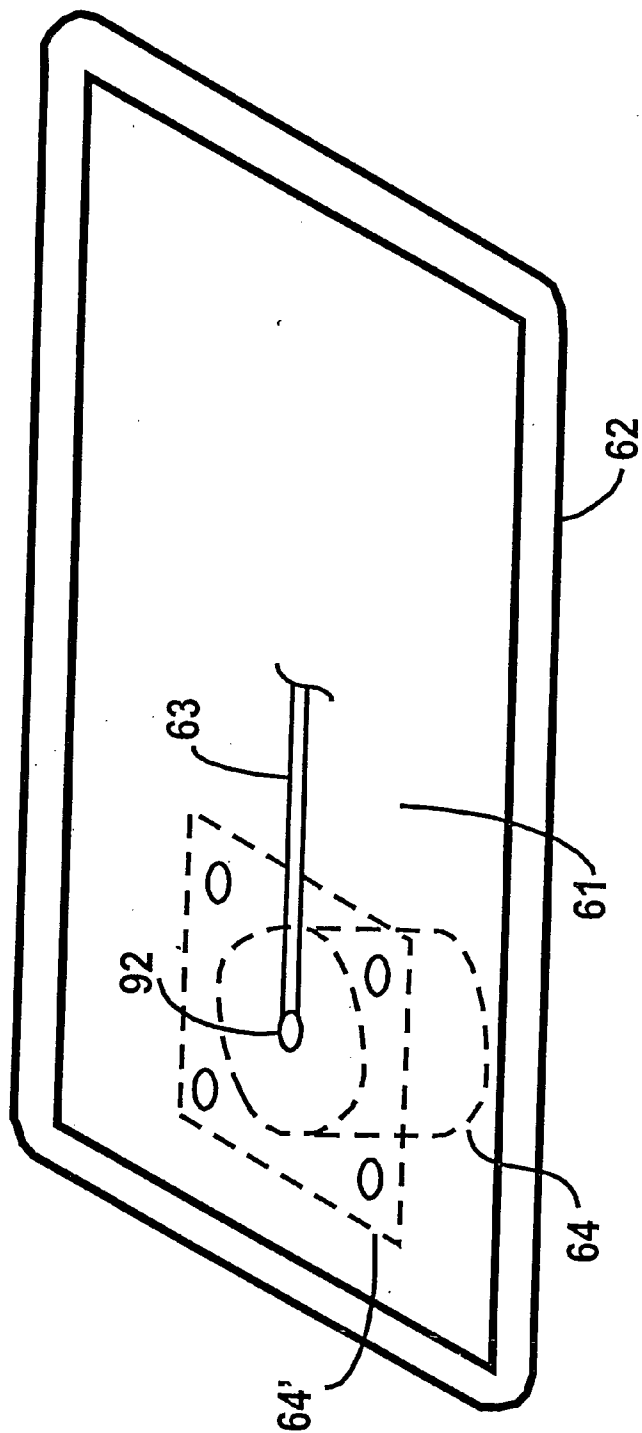
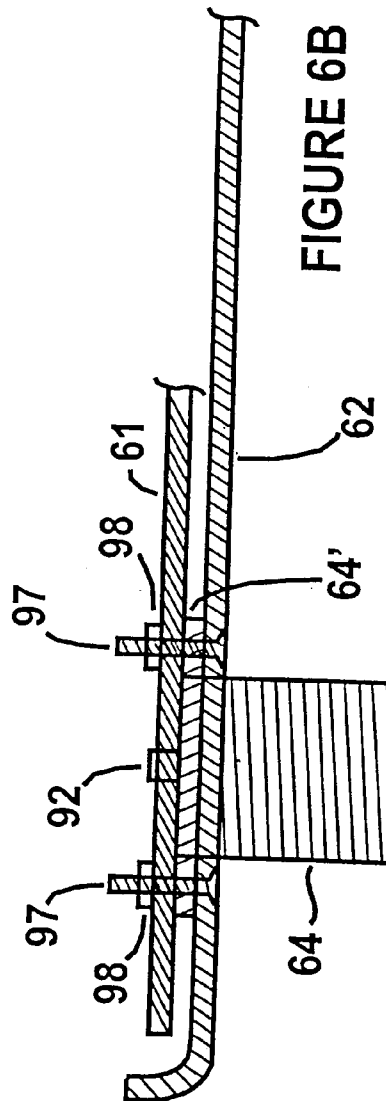

FIGURE 6B



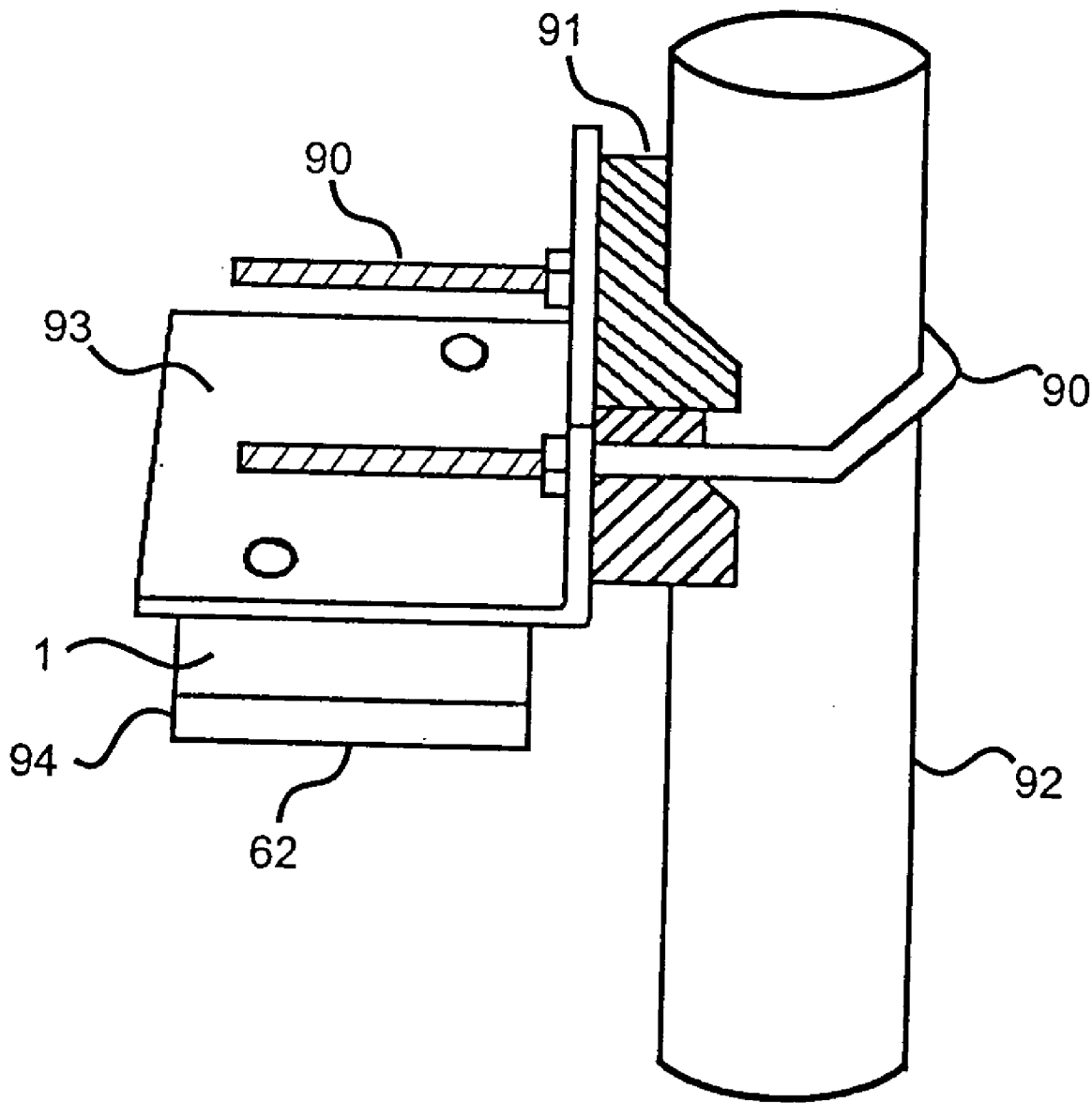
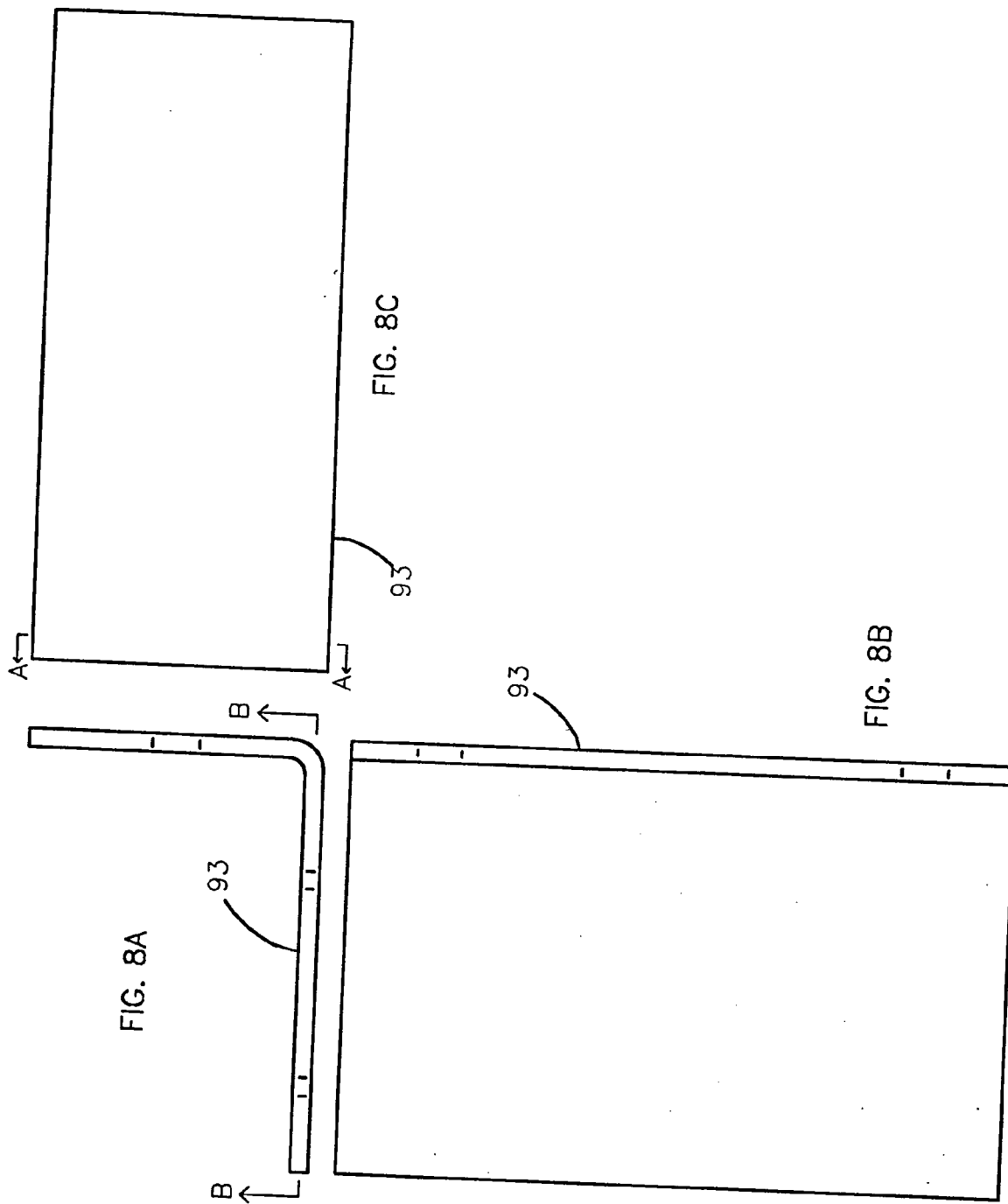
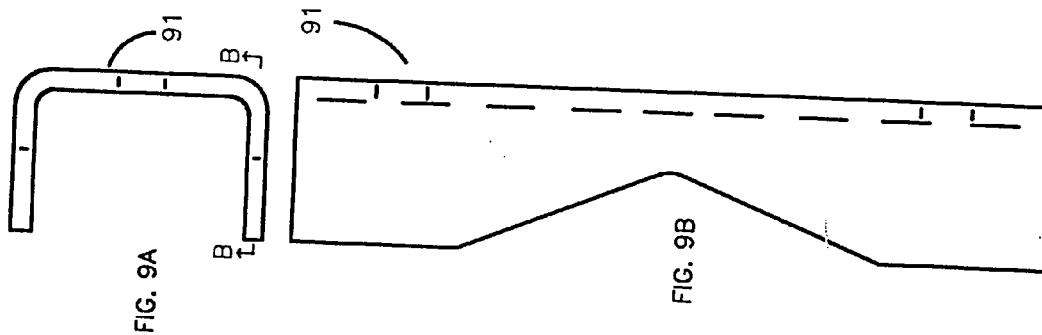
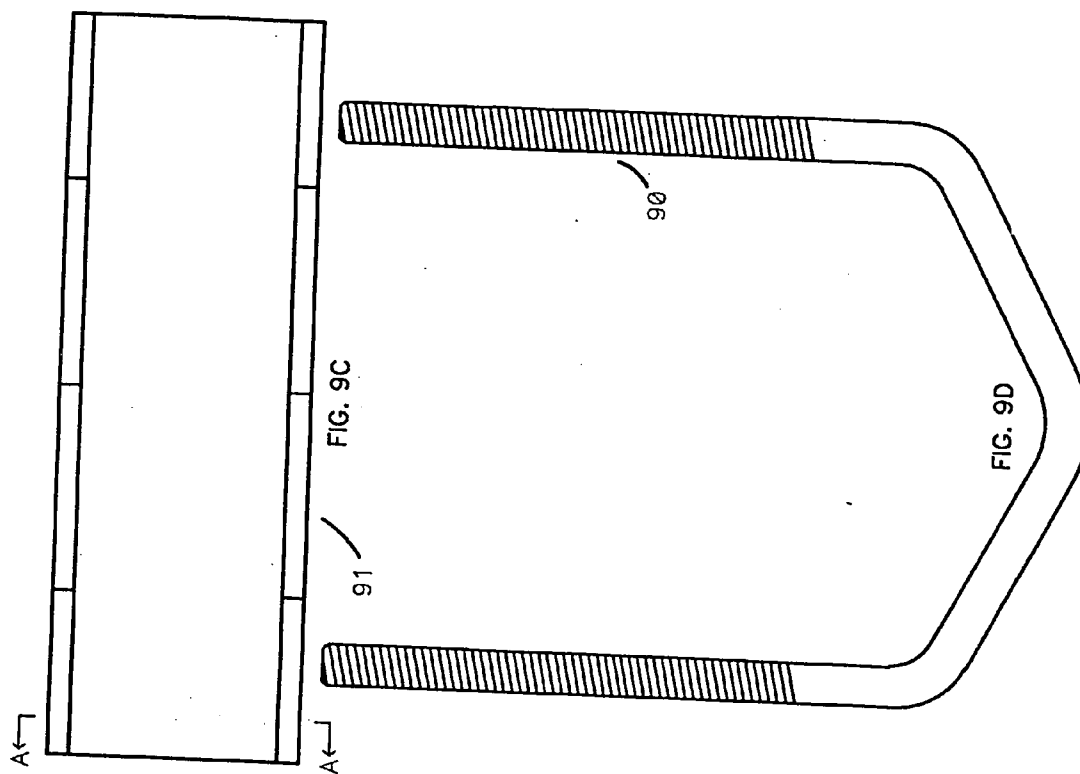

FIGURE 7





ELECTROSTATIC OVERVOLTAGE PROTECTION DEVICE

CLAIM OF PRIORITY AND CROSS REFERENCE TO RELATED APPLICATION

[0001] This application is a divisional of and claims priority to and incorporates by reference, in its entirety, U.S. application Ser. No. 09/505,201, titled "Bi Directional Switched RF Amplifier, Waterproof Housing, Electrostatic Overvoltage Protection Device, and Mounting Bracket Therefor", filed Feb. 16, 2000 and is a Conversion of Provisional Application Ser. No. 60/120,639, filed Feb. 18, 1999

BACKGROUND OF THE INVENTION

[0002] The present invention is a result of the proliferation of low power, Spread Spectrum radio modem devices in the 902-928 MHz, 2.4 GHz and 5.7 GHz bands. Popularity of these radio devices is largely due to FCC regulations that allow appropriately certified radio transceivers to be operated license free. This certification requirement restricts the transmitter output power in order to enable many users to share the band. Further, since the radios are Spread Spectrum devices, they can generally tolerate interference from other radios transmitting in the same geographical area.

[0003] Many of these prior art devices were designed and intended for short range operation (less than 1000 feet, for example, due to the low transmit power restrictions and the requirement of unobstructed line-of-sight between antennas for maximum range). However, if external outdoor gain antennas are placed on tall buildings or radio towers, considerable line-of-sight ranges (measured in miles) are possible. The problem here is that the losses in the typical, inexpensive coaxial transmission line between the radio and the antenna at these frequencies can be excessive unless prohibitively expensive cable is used. Putting an antenna on a tall radio tower or building would give clear line of sight to many locations, but this is largely defeated by the transmission cable loss.

[0004] In a typical RF bi-directional amplifier application, a duplex amplifier with heavy filtering, such as in U. S. Pat. No. 5,502,715 to Penny, is used. However, this is in general unsatisfactory due to the fact that not only are both transmit and receive amplifiers are on at all times, thus leading to wasteful power usage, but also heavy filtering is also necessary to keep the transmit and receive signals from interfering with each other, leading to further expense and power wastage. Still further, since each transmit and receive signal must be put to a separate frequency to avoid interference, this design is wasteful of spectrum bandwidth, a scarce commodity in many applications.

SUMMARY OF THE INVENTION

[0005] It is an object of the invention disclosed herein to overcome these problems and provide a telecommunications system for ranges up to 60 miles point-to-point while keeping the radiated power compliant with the certification regulations.

[0006] It is also an object of the invention to provide an improved arrangement for amplification of transmit and receive radio signals. More specifically, the invention dis-

closes the means to locate a half-duplex, switching bi-directional amplifier close to the antenna.

[0007] It is also an object of the invention to provide such an RF amplifier with an improved waterproof housing enclosure for protection against water accumulation.

[0008] It is still further an object of the invention to provide a universal mounting V bolt mounting bracket for the waterproof housing enclosure.

[0009] It is still further an object of the invention to provide for an improved mounting arrangement for the internal printed circuit boards directly to the housing cover to provide for minimum VSWR from the coaxial connectors to the PC board strip line traces.

[0010] It is still further an object of the invention to provide temperature compensated RF level sensing circuitry to permit reliable operation over a very wide temperature range.

[0011] It is still further an object of the invention to provide LED indicators on the DC injector circuitry to show the operational status of the remote bi-directional switching amplifier by monitoring the current drawn by this remote bi-directional switching amplifier.

[0012] It is still a further object of the invention to provide a solid state switch for switching between the transmit (TX) and the receive (RX) modes of the remote bi-directional switching amplifier.

[0013] It is still a further object of the invention to provide for an electrostatic overvoltage discharge protection device, in one embodiment at the antenna port in the remote bi-directional switched amplifier circuit board, and in another embodiment as a separate component for generalized radio frequency use.

[0014] Additional objects, features, and advantages of the various aspects of the present invention will become apparent from the following description of the preferred embodiments, which description should be taken in conjunction with the accompanying drawings.

BRIEF DESCRIPTION OF THE DRAWINGS

[0015] FIG. 1 shows a typical installation diagram~with the bi-directional switching amplifier in conjunction with the related elements for a telecommunications system.

[0016] FIG. 2 shows how the DC power is inserted into the transmission line to the remote mounted amplifier module through the DC injector circuitry.

[0017] FIG. 3 shows the functional block diagram of the bi-directional switching amplifier module.

[0018] FIG. 4A shows the details of the preferred electrostatic overvoltage discharge protection device used in a circuit board environment such as at the antenna connector on the bi-directional switching amplifier module.

[0019] FIG. 4B shows the details of the preferred electrostatic overvoltage discharge protection device in a separate component form.

[0020] FIG. 5 shows the details of a preferred RF sensing circuit used in the remote bi-directional switching amplifier to enable it to switch from the receive to the transmit mode of operation.

[0021] FIGS. 6A and 6B show the PC board mounted on the housing cover of the bi-directional switching amplifier module or of the DC injector in isometric and side view, respectively.

[0022] FIG. 7 show an isometric view of a preferred bi-directional switching amplifier housing mounting arrangement.

[0023] FIGS. 8A, 8B, and 8C show various views of a preferred universal mounting L-member.

[0024] FIGS. 9A, 9B, and 9C show various views of a preferred implementation of the universal channel bracket to hold the L-bracket against the mounting mast.

[0025] FIG. 9D shows a preferred implementation of the V-bolt used with the universal channel bracket to hold the L-bracket against the mounting mast.

DETAILED DESCRIPTION OF THE PREFERRED EMBODIMENTS

[0026] FIG. 1 show the remote bi-directional switching amplifier telecommunications system in a preferred typical installation. The bi-directional amplifier 1, inside the housing enclosure 94; the DC power input to the housing enclosure 94 from the DC power injector 2 supplied through connection 20, connection between the bi-directional switching amplifier I at 29 to the antenna 87 is made through a short length of inexpensive connecting cable 3 and the L-bracket 93 in conjunction with the mast 92 are the primary preferred components of the remote part of the system. The secondary components include a transmission line 4 connected to the housing enclosure 94 at 20, a DC Power Injector 2 preferably located remote from the bi-directional switching amplifier I housing 94, a DC Power Supply 5 which can be either DC or AC line operated, a radio transceiver 6, an appropriate computer, router or terminal device 7, and connecting cables between the various elements, such as 9 between the DC power injector and the radio transceiver. The connecting cables can be varied in type so long as they are compatible with the system. The object of the invention is to use inexpensive, easily available cables wherever possible.

[0027] The bi-directional switching amplifier I is mounted physically close to the antenna and is preferably, but not necessarily, outdoors. It boosts the low power transmit, TX, signal from the radio transceiver 6 to provide the full transmit output power right at the antenna per Se. It also contains a low noise amplifier (LNA) to pre-amplify the received signal when in receive mode, RX, which overcomes the loss in transmission line 4 to the radio transceiver 6. The bi-directional switching amplifier module I has an RF (radio frequency) sensing circuit to automatically switch from the receive RX mode to the transmit TX mode when the transceiver radio 6 goes into transmit, TX. The details of this bi-directional switching amplifier I are shown in FIG. 3 and described in detail below.

[0028] The DC power injector 2 passes the RF signal through it transparently, and injects a DC voltage onto the transmission line 4 to provide DC power to the remotely mounted bi-directional switching amplifier I in housing 94. The DC power injector 2, as at FIG. 2, has LEDs to indicate when the externally mounted remote bi-directional switching amplifier is in receive, RX, or transmit, TX, modes for operator monitoring.

[0029] One of the preferred features of the invention is the bi-directional switching amplifier module I in housing 94 mounting arrangement and hardware associated with it. This mounting arrangement ensures that the bi-directional switching amplifier housing enclosure 94 is installed with the coax connectors 64 mounted to the cover 62 are facing in a downward direction. This mounting arrangement prevents water accumulation and migration into the housing enclosure 94. This mounting arrangement, in one embodiment, preferably also features a special design "V" bolt 90 that enables the preferred L-bracket 93 in conjunction with the preferred universal channel bracket 91 to be mounted on pole or mast 92 with diameters from ½" to over 3", thus providing for a universal mounting. This completed preferred mounting arrangement is shown at FIG. 7. A specific drawing for each piece is shown at FIGS. 8A to 9D.

The DC Power Injector

[0030] Referring again to FIG. 2, the DC power injector 2 gets DC power from the DC power source 5 through connector 67 and inserts the DC current to the hot lead 72 of the coax connector that connects to the transmission cable through power resistor 66 and choke 63 in order to power the bi-directional switching amplifier electronics. LED indicators 70, 71 are provided to show to the operator that DC power is applied and when the bi-directional switching amplifier module I switches into the transmit mode, TX. The DC power injector 2 also provides the necessary DC blocking to radio transceiver 6 through connector 60 with capacitor 61.

[0031] As seen by referring to the figures, the radio transceiver 6 is connected to the DC power injector 2 via a coax cable 9 at the input connector 60, 64 preferably to a 50-ohm stripline 63 on the PC board 61.

[0032] The RF signal to and from the radio transceiver 6 is coupled to the output connector 72 via a blocking capacitor 61 which keeps the DC voltage from going into the radio transceiver 6. DC voltage is injected onto the bi-directional switching amplifier side of this coupling capacitor 61 from a jack or plug 67 through an RF choke 63 and a power resistor 66.

[0033] The DC voltage drop across the power resistor 66 is a measure of the current drawn by bi-directional switching amplifier I module. Differential voltage comparator circuitry 68 compares this voltage drop to a predetermined level. If the current is less than this predetermined level, the comparator circuitry 68 illuminates the green Receive (RX) LED 71. If the current is greater than this predetermined level, the comparator circuitry 68 illuminates the red Transmit (TX) LED 70.

The Bi-Directional Switched Amplifier Module

[0034] The bi-directional switched amplifier module I circuitry is housed in a watertight enclosure housing 94 physically mounted adjacent to the antenna 87. Hereinafter, the terms "enclosure" and "housing" will be used interchangeably. As shown in FIG. 3, the bi-directional switched amplifier I gets its DC power from the coax transmission line 4 connected to it at the input coax connector 20. The DC power is siphoned off and the RF signal is capacitively coupled to the RF radio transceiver switch 21. Normally the bi-directional switching amplifier I is in the Receive (RX)

mode as **FIG. 3** illustrates. In this mode, RF signals from the antenna port connection **29** are passed through the RF antenna switch **22**, through the optional bandpass filter **27** and amplified by the RX LNA **26**. To reduce the signal and noise coming out of the amplifier, an optional attenuator pad **31** can be installed.

[0035] When the radio transceiver **6** connected to the DC injector **2** goes into the transmit mode, the TX power is detected by the sense circuitry **24** and switches both the switch **21** from the radio transceiver and the switch **22** to the antenna to the TX position. The power sense circuitry **24** also applies DC power to the transmitter power amplifier **25** and removes power from the RX LNA **26**. In this mode, the RF signal from the radio transceiver **6** can be passed through the optional RF attenuator pad **23**, into the transmitter TX power amplifier **25** and to the antenna port **29** via the antenna RF antenna switch **22**. When the radio drops out of transmit, the TX power sense circuitry switches the RF switches **21**, **22** back to the receive RX mode, removes power from the transmitter power amplifier **25** and turns the receive RX LNA **26** back on.

Electrostatic Overvoltage Protection Device

[0036] Another aspect of the invention is an improved electrostatic overvoltage protection device, or "lightning arrester." Here it has been discovered that a conductor of one-quarter the desired wavelength of a predetermined frequency band connected between a source of signal and a reference potential, such as ground, will have almost no effect on the desired signal band and signal transmission but will shunt virtually all frequencies outside this predetermined frequency band to a reference potential such as ground, thus protecting the integrity of any electronic component connected to the signal input.

[0037] In a first preferred embodiment, the electrostatic overvoltage protection for an electronic circuit in a circuit board environment, such as the bi-directional switching amplifier, is shown in **FIG. 4A**. This protector can protect against lightning, electrostatic charge from the environment, an Electro Magnetic Pulse ("EMP"), and any other source of static or transient overvoltage. The coax connector **29** that connects to the antenna in a preferred embodiment has a loop of heavy gauge conductor **91** of a length equal to one-quarter of the wavelength of the desired RF operational band connected from the signal input **92** of connector **29** to a source of reference potential, such as ground **93** on the PC board, thus forming an RF choke to that desired frequency band at the input and a direct ground to all other frequencies. This conductor **91** may also be a trace on the PC board or any other convenient means of forming an equivalent one-quarter wavelength conductor such that it shorts the center pin **92** directly to a reference potential such as ground **93** on the PC board for all frequencies outside the desired frequency band. This RF shunt choke is has a negligible effect on the desired RF band signal passing through the amplifier. However, any stray DC, lightning, or other electrostatic overvoltage fault at the input pin **92** of the antenna connector **29** finds this loop a very low impedance to ground (provided that the mast or pole is properly grounded) and shunts the current through it to this ground, thereby protecting the electronic circuit board, such as the bi-directional switching amplifier **1**.

[0038] A second embodiment of the electrostatic overvoltage protection device is in a separate component form with

both the internal and external details are shown at **FIG. 4B**. The protection device, or arrester, is constructed of a T-connector housing **100** with input connection **101** and output connection **102**. The input **101** and output **102** are bi-directional and may be interchanged. A pass-through conductor **103** connects the input **101** and output **102**, and conductor **103** is surrounded by a suitable dielectric material **112** which is inside of the body housing **100**. The dielectric material **112** may also be air or a material such as rexolite, delrin, teflon or other non-conductor suitable for the radio frequency band intended. The dielectric material **112** may be a combination of air and other non-conducting materials.

[0039] Here the one-quarter wavelength protector of the desired frequency band, taking into account the dielectric constant of the dielectric material **112**, is conductor **104** which connects to the through conductor **103** at one end, and to a grounding or shorting member to the outside housing at the other end. One manner of achieving this shorting to the outside Tconnector housing **100** is shown here through a ground pin such as **105** on the ground end. Here the ground pin **105** extends through an end cap **106** and thus forms an effective short to the external protector housing **100** for the conductor **104**. The connector-protection device **100** can then be put to a source of reference potential such as ground by any convenient manner. In one preferred embodiment, the ground pin **105** extends beyond the housing **100** to form a suitable ground screw **110**. As above, the total length of the conductor **104** and ground pin **105** is one quarter wavelength, $\lambda/4$, length **108** (or any odd multiple of one quarter wavelength) of the desired operating frequency as measured from the pass-through conductor **103** to the end cap assembly **106**. As above, this presents a short circuit to direct currents (DC) and any non-desired frequency and a high impedance only to the desired operating frequency band. The assembly of conductor **104**, ground pin **105**, end cap **106**, and ground screw **110** may be constructed as one continuous piece, if desired.

[0040] The end cap **106** can attach to the main body of the arrester **100** by either an internal or external thread **107** (male or female connection) or any other suitable means of connection. In one simple preferred embodiment the ground screw **110** which passes through the end cap **106** is used for the attachment of a grounding conductor III, which can be a combination lug and/or braid, and held in place by nut **109**. The ground screw **110** may be of any length and is preferably highly conductive. Washers or other appropriate mounting hardware may be used between conductor III, end cap **106** and nut **109**. Ground conductor III may also be attached to end cap **106** by soldering, riveting, welding or any other method.

[0041] Still further, the shorting of conductor **104** to the housing **100** at the ground end can be done by any other convenient means such as a copper foil, a highly conductive plate soldered, brazed, or welded in place, or any other conductor connection between the distal end of conductor **104** and the housing **100** in place of this end cap **106**, which is only one convenient manner of providing this connection, and a threaded member is not necessary, but useful in some situations to tune the desired band.

[0042] This separate component protection device of **FIG. 4B** can have an entire range of other uses other than as an antenna protector, for instance such as protecting signals

between computers or other communications devices, protection of control signals to power equipment, or any kind of networking where there may be some kind of electrostatic or transient overvoltage fault condition in a radio frequency path of a particular predetermined frequency band connection.

The RF Power Sense Circuitry

[0043] The RF Power Sense Circuitry **24** best seen in **FIG. 5**, needs to detect low level RF signals and work in hostile outdoor environments. It is vital that the bi-directional switching amplifier module **I** quickly and reliably detect the presence of a transmitted signal from the radio transceiver **6** under all temperature ranges in order to switch from the Receive RX to the Transmit TX mode. The present invention utilizes a solid state circuit that senses and detects the presence of radio frequency energy (RF) and provides a digital output signal when said Transmit TX RF signal is present. The sensing circuitry **24** utilizes detection diodes **40, 40'** that are forward biased to almost the point of conduction to provide for maximum sensitivity and reliable detection for signal levels as low as **1** milliwatt. The biasing circuitry for these diodes are temperature compensated with a temperature-controlled resistor (thermistor) **39** to ensure consistent performance over a wide temperature range.

[0044] Referring to **FIG. 5**, RF energy from the bi-directional switching amplifier **I** input connector **20** is coupled via a capacitor **41** to the junction of the preferred low capacitance Schottky dual diodes **40, 40'** in series. While any suitable diodes can be used, these have been found to be cost effective, reliable components well suited for this application. These diodes **40, 40'** combined with capacitors **42, 45** form a voltage doubling circuit to rectify and detect an RF signal on the input connector **20**. The resulting rectified signal is applied to an input **58** of a comparator **53**.

[0045] To provide for maximum sensitivity, diodes **40, 40'** are forward biased to just below the conduction point via a 5 volt regulated source **59** through the biasing resistors **43, 44, and 46**. However, since the transconductance of the diodes **40, 40'** change greatly with temperature, a thermistor **39** is added to the circuit. This thermistor **39** adjusts the current flow through the diodes **40, 40'** to provide a relatively uniform RF signal level detection point over a very wide temperature range.

[0046] The trip point for the circuitry is set by the voltage reference source **50**. When the DC voltage present on input **58** exceeds the pre-set DC level on input **57**, the comparator **53** changes state indicating that an RF signal is present at the input connector **20**. The output **56** of this comparator **53** goes low. A second comparator **55** inverts this signal and provides a complementary logical high output at **54** for use by the RF switching and other circuitry in the bi-directional switching amplifier module.

The Preferred Mounting Arrangement for the Bi-Directional Amplifier Module

[0047] Waterproof enclosures, even if mounted properly, can ultimately have a water leak when mounted outdoors through the coaxial connectors that penetrate its surface. The present invention discloses a preferred arrangement to mount such a waterproof enclosure or housing **94** containing

the bi-directional switching amplifier module **1** outdoors especially to a pole or mast **92** mounted physically close to the radio antenna **87**. The antenna **87** can be at any adjacent position to the enclosure housing **94**, i.e. above the enclosure, at the same height, or below the enclosure. In the preferred embodiment, the mounting of the enclosure **94** for the bi-directional switching amplifier **I** has the connectors facing in a downward direction. Especially when used with drip loops, this mounting arrangement results in water being drawn away by gravity from the waterproof enclosure **94** and the external connections rather than giving it a direct path to enter such as would be the case if the connectors **20, 29** were installed on any other face of the enclosure **94**. The connection to the antenna **87** is also preferred to be in a downward position to minimize water migration into the connecting cable **3**.

[0048] Further, conventional U-bolts mounting means or any other conventional structure for adjustably mounting the antenna **87** and housing **94** can be used with the invention. Conventional U-bolts and round masts **92** would be particularly useful in a new installation of many units where all the mounting means would be the same. However, in retrofit installations U-bolts only lend themselves to mountings on a very limited range of pole or mast diameters. Thus while U-bolts can be used with the invention, a preferred new and improved universal mounting means overcomes problems associated with these limitations by enabling installers to use a wide range of masts or poles **92** to mount the waterproof enclosure **94** and antenna **87**. A new mounting bracket **93** and V-bolt design **90** such as described herein enables the amplifier enclosure **94** to be mounted on any diameter mast or pole **92** from $\frac{1}{2}$ " to over 3" diameter. Thus during field installations, and especially retro-fit installations, an installer would not have to locate a mast or pole of particular diameter to accommodate the limited range of the diameter of standard U-bolts mounting arrangements, but could bolt the mounting hardware to just about anything in this universal arrangement.

[0049] This preferred universal mounting arrangement is shown in **FIGS. 7, 8A-8C, and 9A-9D**. It comprises the V-bolt **90**, a stepped channel piece **91** for the V-bolt and pole **92** to work against, L-bracket **93** to secure the channel piece **91** to the bi-directional switching amplifier module housing **94** and the nuts and washers **95** needed to hold the V-bolt **90** against the back of the L-bracket **93**. Thus the bi-directional switching amplifier module housing **94** is secured as designed with the connectors **20, 29** facing downward. As seen in **FIG. 7**, the L-bracket **93** provides convenient mounting for the amplifier housing **94** to the V bolt **90** as well as providing additional weather protection as a roof-covering.

Description of Preferred the PC Board Mounting Arrangement

[0050] The Printed Circuit (PC) boards **61** containing the electronic circuitry for the bi-directional switching amplifier module **I** and DC power injector **2** are preferably mounted to the top cover or lid **62** of their respective enclosures. This permits the coax connectors **64** to be mounted directly to the PC board **61**, which provides for the best impedance match from these connectors to the PC board **61**, with the PC board **61** traces **63** acting as strip lines to the circuitry on the board.

[0051] **FIGS. 6A and 6B** show how the PC board **61** is preferably-typically mounted to the top cover or lid **62** of

the enclosure. The coax connectors **64**, for example N-female type, protrude through holes on the top of the cover **62**. The flange **64'** of connector **64** is sandwiched between the inside of the top cover **62** and the ground plane bottom of the PC board **61**. The flange **64'** of the connector **64** is fastened between the top of the cover **62** and the bottom PC board **61** using appropriate machine screws **97** and nuts **98** or any other fastening scheme intended by the manufacturer of the connector **64**. The center pin **92** of the connector is soldered or otherwise electrically connected directly through to the PC board **61** to trace **63**, which forms a preferably 50-ohm stripline to the rest of the RF circuitry. The ground connection to the PC board is secured through four mounting screws **97** or other equivalent fastening means. This presents the lowest VSWR to the transmission line connected to the device on **61** through the connector **64** and provides for the least possible loss.

[0052] A highly efficient RF bi-directional switching amplifier, housing, universal mounting and electrostatic overvoltage protection means are disclosed for a modern telecommunications system. Thus by using the disclosure and teachings of the invention, any practitioner in the art is enabled to make and use the invention.

What we claim is:

1. In a telecommunications device having a signal input, an electrostatic overvoltage protection device, comprising:
 - a conductor connected between said signal input and a source of reference potential.
2. The electrostatic overvoltage protection device of claim 1, wherein:

- said conductor has a length selected to be one quarter of the wavelength of a desired signal band frequency, and the source of reference potential is a ground potential.
3. The electrostatic overvoltage protection device of claim 2, wherein:
 - the conductor of one quarter wavelength is one of a trace on a circuit board and a wire.
4. The electrostatic overvoltage protection device of claim 2, further comprising:
 - a T-connector having an external housing and with a through conductor between the main end terminals, and a side conductor connected at one end to the to said through conductor and at the other end to the side end terminal of said T-connector, and
 - a shorting structure connecting said other end of said side conductor to said T-connector external housing, wherein said conductor of one quarter wavelength is measured from said one end of said side conductor to said shorting structure.
5. The electrostatic overvoltage protection device of claim 4, wherein:
 - said shorting structure further comprises a conductive cap with a conductive pin adapted to fit into said T-connector side end terminal and thus make electrical connection between the combination of said conductive pin and said side conductor and said T-connector external housing.

* * * * *