

S. W. & J. F. Palmer,

Towing.

No. 109,045.

Patented Nov. 8, 1870.

FIG. 1.

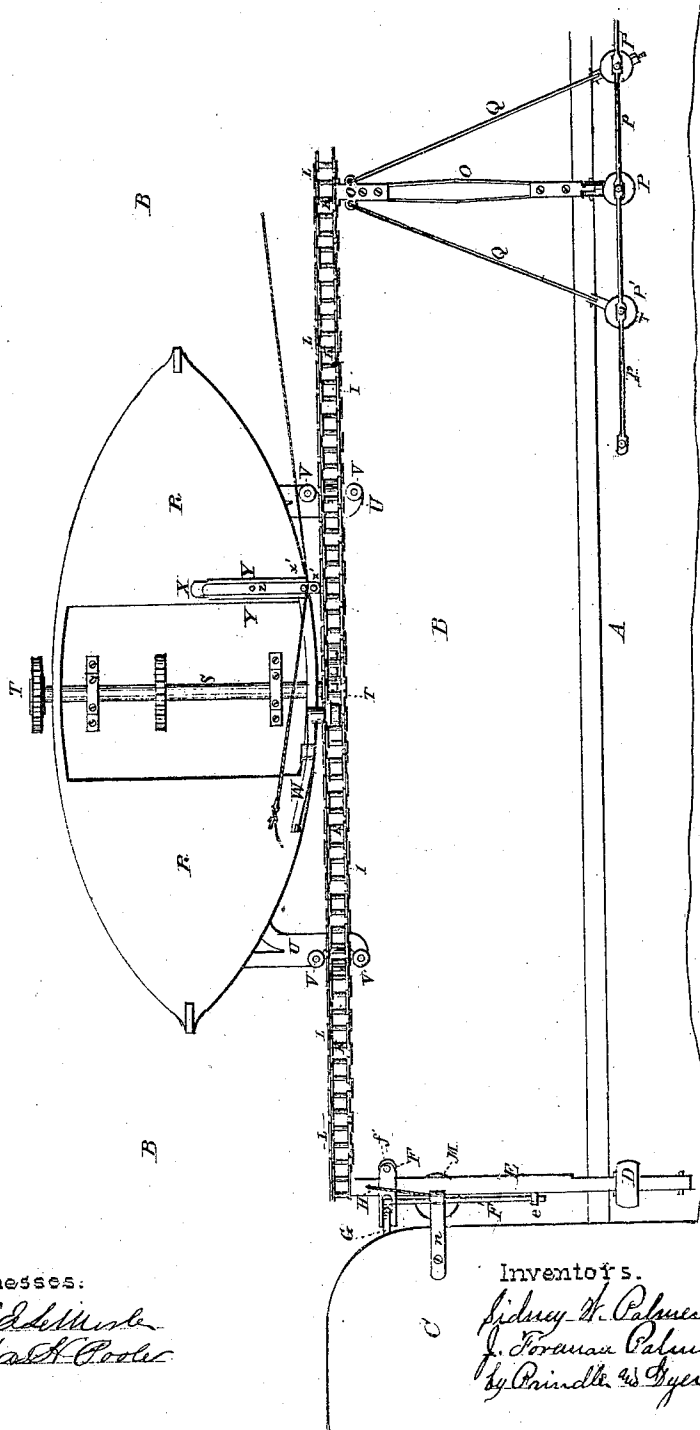

Witnesses:

Admiral
Chas. C. Cook

Inventors.

Sidney W. Palmer
J. Foraman Palmer
by Birdell & Tyler

Attys.

S. W. & J. F. Palmer,

3 Sheets Sheet 2

Towing.

No. 109,045.

Patented Nov. 8. 1870.

Fig. 2.

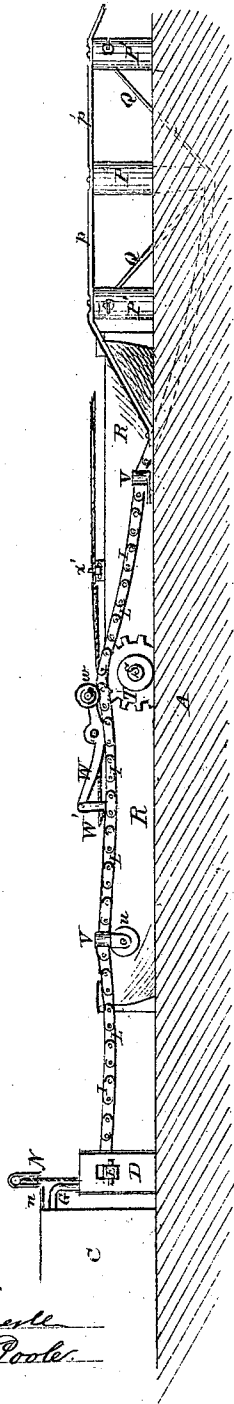

Witnesses.

Edell M. ...
Chas. H. Poole.

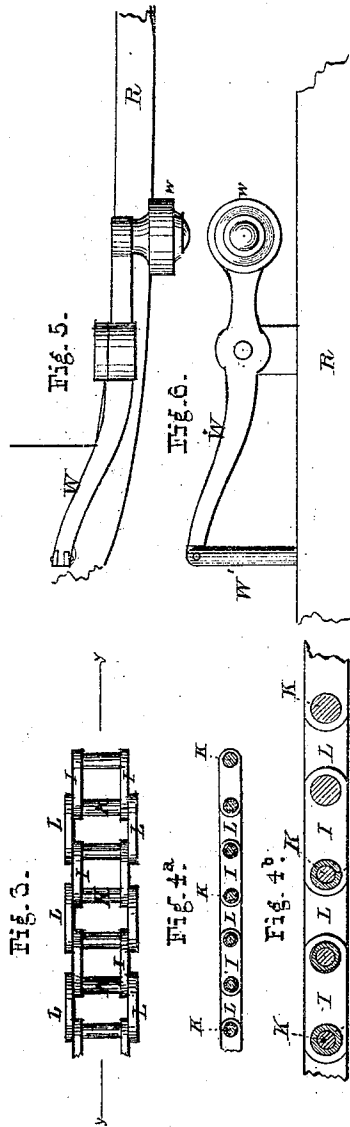

Inventors.

Sidney W. Palmer
J. Foreman Palmer
By Rinsell & Myers

Attys

S. W. & J. P. Palmer, Towing.

No. 109,045.

Patented Nov. 8, 1870.

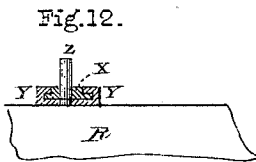
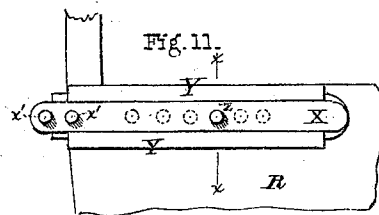
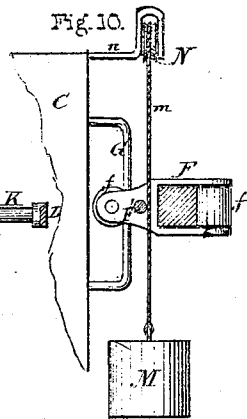
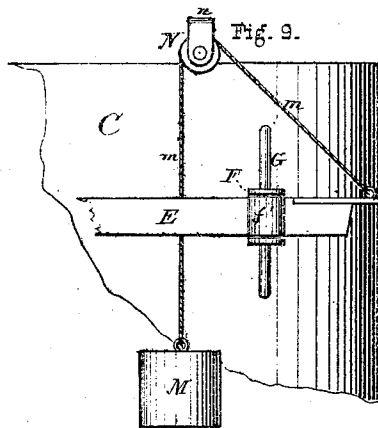
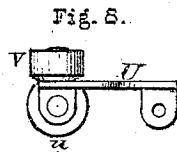
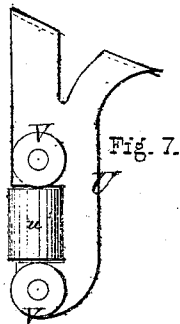

Witnesses.

Adelbert
Chas. P. Cook

Inventors.

Jedrey W. Palmer
J. Fortman Palmer
by Raindle & Fry
Attys.

United States Patent Office.

SIDNEY W. PALMER AND JOSIAH FOREMAN PALMER, OF AUBURN, NEW YORK.

Letters Patent No. 109,045, dated November 8, 1870.

IMPROVEMENT IN APPARATUS FOR TOWING CANAL-BOATS.

The Schedule referred to in these Letters Patent and making part of the same.

To all whom it may concern:

Be it known that we, SIDNEY W. PALMER and JOSIAH FOREMAN PALMER, of Auburn, in the county of Cayuga and in the State of New York, have invented certain new and useful Improvements in Apparatus for Towing Boats; and do hereby declare that the following is a full, clear, and exact description thereof, reference being had to the accompanying drawing making a part of this specification, in which—

Figure 1 is a plan view of a section of our apparatus as applied to a canal at a lock;

Figure 2 is a side elevation of the same, looking from the tow-path;

Figure 3 is a plan view of a section of the towing-chain;

Figures 4^a and 4^b are vertical longitudinal sections of the same, the latter figure being somewhat enlarged;

Figure 5 is a plan view of the locking devices for confining the chain in engagement with the toothed driving-wheel, carried by and operated upon the boat;

Figure 6 is a side elevation of the same;

Figures 7 and 8 are a plan view and a side elevation, respectively, of the roller-braces for supporting the chain near either end of the boat;

Figure 9 is a side elevation of the boom for supporting the chain at the entrance to the lock;

Figure 10 is a rear elevation of the same;

Figure 11 is a plan view of the guide for controlling the lateral position of the line employed for towing barges; and

Figure 12 is a vertical cross-section of the same on the line *z z* of fig. 11.

Letters of like name and kind refer to like parts in each of the figures.

Our invention has for its object the providing of suitable mechanism, permanently secured in position along the sides of a canal, upon or by means of which the motive power of a tug-boat may be caused to act so as to enable said boat to be propelled within said canal; and

It consists, principally, in the employment of a chain extending beside or within a canal, and capable of receiving and engaging with a toothed wheel secured upon and revolving with a shaft suitably journaled upon a boat, substantially as hereinafter set forth.

It further consists in a series of braced booms pivoted at one end to or upon the bank of the canal, so as to have a vertical motion only, and having their other or outer ends attached to the towing-chain or other equivalent device, so that, while allowing to said chain free vertical motion, they shall receive and sustain all

lengthwise strain upon the same, as is hereinafter shown.

It further consists in the employment of a guard for passing ordinary tow-lines over the pivoted booms, substantially as is hereinafter set forth.

It further consists in the employment of a pivoted sliding boom for sustaining the end of a towing-chain at a lock, substantially as hereinafter shown and described.

It further consists in the employment of suitable weights for counterbalancing the boom and chain or either separately, substantially as is hereinafter specified.

It further consists in the construction and relative arrangement of the devices for receiving and sustaining the friction of the outer end of the pivoted and sliding boom, substantially as is hereinafter set forth.

It further consists in the construction of friction-roller braces for sustaining and guiding the towing-chain, substantially as is hereinafter shown.

It further consists in the peculiar construction of the device for locking the towing-chain in engagement with the driving-wheel, substantially as is hereinafter set forth.

It finally consists in the employment of a transversely-sliding guide for containing and regulating the position of the barge tow-line, substantially as and for the purpose hereinafter specified.

In the annexed drawing—

A represents the bank or tow-path;

B, the water of an ordinary canal; and

C, the side wall of a lock of usual form.

Projecting vertically upward from the bank B, near the wall C, is a post, D, having near its upper end a rectangular opening for the reception of one end of a wooden bar, E, which from thence extends outward at a right angle to the line of the canal, with its outer end about in a line with the inner face of said wall.

The outer end of the bar E passes through a corresponding opening in a sheave-block, F, which, as seen in fig. 10, is pivoted upon a vertical guide, G, secured to the face of the wall C, so that said sheave-block and bar may together have thereon a free vertical motion, while at the same time the latter may move longitudinally within the former.

A grooved pulley, *f*, pivoted within said sheave-block, so as to bear against the inner side of the guide G, and a plain roller, *f'*, so pivoted within said sheave-block as to receive all horizontally outward pressure upon the bar E, removes nearly all of the friction upon said bar and block, and renders their operation comparatively easy.

Secured to and projecting horizontally outward from the end of the bar or boom E is a metal bar, H, having its outer end bent vertically downward and attached to one end of a chain, which, as seen in figs. 3 and 4, consists of a series of links, each formed of two washers, I, secured together in parallel lines by means of two studs, K, having their ends reduced in size and fitted into corresponding openings provided in and through the ends of said washers, the inner faces of which have a bearing against shoulders formed by reducing the ends of said studs.

The ends of the studs K project outward beyond the washers I to a distance equal to the thickness of the latter, and each receive one end of a second washer, L, the opposite end of which is in like manner pivoted upon a stud of another link, binding said links together and forming from them a chain.

The washers L are held in position upon the stud by slightly heading down the ends of the latter; but, if desired, said ends may project sufficiently to receive a screw-thread and nut.

Another form of construction is employed in which the studs are of uniform size throughout their entire length, with a tube or sleeve fitted over each between the washers, for the purpose of causing the latter to retain their relative parallel positions, the end of said tube forming shoulders, against which the inner faces of said washers bear.

Although a chain constructed as described is preferred for towing purposes, other forms may be employed, or, if desired, a rope may be substituted for the same.

It being necessary that the end of the chain should be held in position nearly in a line with the deck of a boat, and yet be capable of a vertical and of a horizontal movement, in order that it may be varied to suit the position of boats entering or leaving the lock, the outer end of the boom E is counterbalanced by means of a weight, M, suspended from a cord or chain, m, which passes upward over a pulley, N, (pivoted within a brace, u, secured to and projecting outward from the wall C, and from thence, passing outward and downward, has its end secured to the bar H. As thus arranged any downward or outward movement of the chain and boom will elevate the weight, which, upon releasing said chain or boom, will return them to their usual positions.

A rod, F', secured to the sheave-block F, and extending rearward parallel with the inner face of the boom, with its inner end passing through a staple, e, secured to and projecting outward from the face of said boom, furnishes an additional guide or brace for said sheave-block, by means of which its position with relation to the line of said boom is at all times maintained.

In order that the chain may be kept at a uniform distance from the bank, and also that the strain upon said chain may be thrown upon comparatively short sections, the following-described means are employed:

A boom, O, is pivoted at one end to a suitable post, P, fixed within the bank A, so as to have a vertical movement only, and projecting outward, over, or within the canal has its free end connected to the chain by a bar, o, similar in construction to the bar H upon the boom E.

Two brace-rods, Q, connected to opposite sides of the bar o extend shoreward and outward, and have their rear ends pivoted to the posts P', placed within the bank, in a line with and equidistant from the post P.

As thus arranged, the boom offers no resistance to the vertical movement of the chain, but being strongly braced laterally, receives and sustains any lengthwise strain thrown upon the same, and thus renders it possible to use a much lighter chain than

would be the case if the strain exerted upon one portion was distributed over its whole length.

Another advantage arises from the entire independence of the sections, whereby a breakage of the chain at one point can only affect its use between the booms next adjoining.

A rod, p, secured across the upper side of the posts P and P', and extending downward at an angle of about forty-five degrees from either side, in a line with the canal, serves as a guard or guide for raising and passing ordinary tow-lines over the boom.

The tug-boat, R, intended for use with this apparatus, is preferably a double-ender, so as to enable it to run in either direction, although any form of boat would operate with equal certainty.

A shaft, S, extending transversely across the boat, and connected with any suitable driving mechanism, is provided upon each end, which projects outward beyond the side, with a wheel, T, having upon its periphery a series of teeth, t, projecting radially outward, which teeth correspond in size to the spaces between the studs and washers composing the chain, so as to permit of their engagement when said chain is caused to rest upon the upper side of said wheel.

Projecting horizontally outward from the side of the boat, near either end, is a brace, U, within which is provided a roller, u, corresponding in length to the width of the chain, with its axis placed horizontal and at a right angle to the line of the boat.

Two other rollers, V, pivoted vertically upon the brace, at either end of the roller u, completes the device, the object of which is to furnish a support and guide for the chain, so as to relieve the driving-wheel T of all unnecessary weight and strain.

In order to hold the chain in engagement with the driving-wheel, and prevent its accidental displacement therefrom, a lever, W, provided upon one end with a roller, w, is pivoted upon a brace, r, secured to and projecting upward from the deck of the boat, in such a position as to cause said roller to rest upon said chain immediately over said driving-wheel.

A bar, W', corresponding in length to the distance between the rear end of the lever W and the deck of the boat, is pivoted at one end to the end of said lever and resting upon said deck, as shown in fig. 6, securely locks said lever in position.

When desired to remove the chain from the driving-wheel, the bar W' is turned upward, and the rear end of the lever W depressed so as to raise the roller w from off said chain.

It may be found advantageous to employ the rollers for holding the chain in engagement with the driving-wheel when the boat is moving in either direction, in which event the additional roller should be placed a little behind the center of said wheel, and may either be pivoted to the lever X, or to a separate lever.

The power necessary to drive the tug-boat being applied at one side, it is necessary that the connection between said boat and such barges as it may tow, be also made upon the same side, and as the resistance offered by the barges will vary with their number and freight, it has been found necessary to vary the position laterally of the tow-line connection, in order that the draft may be rendered uniform, and less difficulty experienced in steering the boat.

To accomplish such result, the bar X, having near one end, two upward projecting studs x x, is placed within corresponding ways or guides Y, extending from the edge of the deck inward, at a right angle to the line of the boat, said bar being loosely fitted so as to have free longitudinal motion within said ways.

A series of holes, y, are provided in and through the center, transversely of the ways Y, and a single hole, corresponding in transverse position, is pro-

vided in the bar X, so that if said bar be adjusted longitudinally until its opening corresponds with one of the openings within said ways, the former may be locked in position by means of a pin, *z*, passed downward through said opening.

As thus constructed, the tow-line is passed between the studs *x*, and the bar adjusted in or out, as occasion may require.

Another object sought by the lateral adjustment of the tow-line is to counteract the side draft of the tug, and it may be used even for the purpose of steering the same, in which event a lever, hand-wheel, or other equivalent actuating device would be required.

In actual operation, it is designed that a chain shall be extended along either side of the canal, in which event the boat would be provided with two sets of supporting roller-braces and two driving-wheels, so as to render it unnecessary for them to turn around while traveling in different directions, and also to enable them to make use of the left-hand chain, in order to pass a break in the other.

It is expected that each tug will carry a supply of links, washers, and studs, so that any breakage of the chain may be speedily repaired by the removal of the damaged portions and the substitution of others.

Although it is deemed best to have the chain terminate at either end of the lock, as shown, if desired, it may be extended through or over such lock, appropriate devices being employed for raising said chain over the gates while they are being opened or closed.

Having thus fully set forth the nature and merits of our invention,

What we claim as new is—

1. In combination with a towing-chain, or other equivalent device, extended beside, over, or within a canal, a series of pivoted braced booms, substantially as shown, and for the purpose set forth.

2. The hereinbefore described towing-chain, consisting of the washers I and L, connected together by means of the studs K and sleeves *k*, substantially as described and shown.

3. In combination with the boom O and posts P and P' the rope guard *p*, substantially as and for the purpose described.

4. The pivoted and sliding boom E, constructed as described, in combination with the towing chain or other equivalent device, substantially as and for the purpose shown.

5. The construction and relative arrangement of the sheave-block F, provided with the pulleys *f* and *f'*, the guide G, the rod F', and the staple *e*, in combination with the boom E, substantially as shown, and for the purpose specified.

6. The weight M, the cord *m*, and the pulley N, or their equivalents, in combination with the boom E, and towing-chain, substantially as described, and for the purpose set forth.

7. The braces U, provided with the rollers *u* and V, for the purpose of sustaining and guiding the towing-chain, substantially as described.

8. The lever W, provided with the roller *w*, in combination with the pivoted bar W', or its equivalent, substantially as shown, and for the purpose specified.

9. The combination of the lever W, provided with the roller *w*, with the driving-wheel T, and the towing-chain, substantially as and for the purpose shown.

10. The sliding-bar X, provided with the studs *x*, the ways Y, and the pin *z*, for the purpose of changing the point of draft of the tow-line, substantially as shown and described.

In testimony that we claim the foregoing, we have hereunto set our hands this 9th day of August, 1870.

SIDNEY W. PALMER.

JOSIAH FOREMAN PALMER.

Witnesses:

HORACE T. COOK,
HENRY C. COBB.