



Europäisches Patentamt
European Patent Office
Office européen des brevets



(11) **EP 0 879 197 B1**

(12) **EUROPEAN PATENT SPECIFICATION**

(45) Date of publication and mention
of the grant of the patent:
15.03.2000 Bulletin 2000/11

(51) Int Cl.7: **B65H 5/00**, B26F 1/44,
B31F 1/08

(21) Application number: **96928615.2**

(86) International application number:
PCT/GB96/02131

(22) Date of filing: **27.08.1996**

(87) International publication number:
WO 97/28074 (07.08.1997 Gazette 1997/34)

(54) **CREASING MACHINES**
MASCHINE ZUM EINKERBEN
MACHINES DE RAINAGE

(84) Designated Contracting States:
**AT BE CH DE DK ES FI FR GB GR IE IT LI LU MC
NL PT SE**

(72) Inventor: **BEST, Thomas**
Pirchington, Kent CT7 9LB (GB)

(30) Priority: **30.01.1996 GB 9601827**

(74) Representative: **Fry, Alan Valentine et al**
FRY HEATH & SPENCE
The Old College
53 High Street
Horley Surrey RH6 7BN (GB)

(43) Date of publication of application:
25.11.1998 Bulletin 1998/48

(73) Proprietor: **Trimplex Limited**
London SE28 0AQ (GB)

(56) References cited:
EP-A- 0 256 957 **DE-U- 9 114 037**
DE-U- 9 214 654 **DE-U- 9 411 502**
US-A- 3 884 132 **US-A- 5 163 894**

EP 0 879 197 B1

Note: Within nine months from the publication of the mention of the grant of the European patent, any person may give notice to the European Patent Office of opposition to the European patent granted. Notice of opposition shall be filed in a written reasoned statement. It shall not be deemed to have been filed until the opposition fee has been paid. (Art. 99(1) European Patent Convention).

Description

[0001] The present invention relates to creasing machines. Such machines are commonly employed to perform crease lines in cardboard or corrugated cardboard, but the present invention is not limited to such applications.

[0002] Known creasing machines (see DE-U-9411502.8) comprise platens which carry creasing matrices formed of matrix elements which project from the platen surface and have small gaps therebetween. Above each such gap is a creasing rule of the platen which is movable in a direction substantially perpendicular to the surface. In its raised position, the creasing rule stands clear of the creasing matrix whilst in its lower position the creasing rule projects into the area between the matrix elements.

[0003] To produce a crease line in a cardboard sheet, the creasing rule is moved to its raised position, and a sheet moved substantially parallel to the platen until the desired crease line lies between the respective gap and the creasing rule. The creasing rule is then moved sharply into its lowered position, and then to its raised position. A crease is thus produced in the sheet.

[0004] Clearly, to obtain a higher throughput in the creasing machine it is necessary to move the cardboard sheet quickly. A problem with this is that the leading edge can begin to drop, and it is not uncommon for it to strike one or more of the matrix elements. Once this happens, that sheet is damaged, and will often jam the machine. When a jam occurs, the machine must be stopped in order for it to be cleared.

[0005] An object of the present invention is to overcome this problem.

[0006] The present invention provides in one aspect a creasing machine for imparting a crease to a creasable article, the machine comprising a platen, a creasing matrix secured to the surface of the platen and upstanding therefrom, and a creasing rule moveable transversely between a position spaced from the creasing matrix and a position adjacent or within the creasing matrix; and a strip positioned ahead of the creasing matrix and in the path of the article to be creased, the strip having a profile whose leading edge is curvilinear and whose undersurface lies flush with the surface of the platen at all times, the profiled strip acting to deflect an incoming article thereby preventing or minimising contact between the article with an upstanding face of the creasing matrix.

[0007] The profiled strip may be adhered to the platen surface by, for example, double-sided tape. In this arrangement the tape is adhered to the strip undersurface over only a recessed rear portion of the strip undersurface, the leading portion of the profiled stipe lying flush with the platen surface.

[0008] The profiled strip operates *inter alia* to create a vortex in the boundary layer around the moving article which creates lift in those cases where the incoming ar-

ticle is liable to strike the creasing matrix. Should contact occur between an incoming article and the profiled strip, the profile of the strip prevents damage occurring to the article thereby preventing jamming of the machine.

[0009] Thus, the present invention is capable of working in both a contactless fashion and one in which damage or jamming does not occur should there be contact between the article and the profiled strip. A preferred profile is an aerodynamic profile having a thickness for the aerodynamic profile is between one and two times the height of the creasing matrix.

[0010] Equally, the exact positioning of the strip is not essential so long as the functional requirement is met. However, a suitable spacing between the creasing matrix and the strip is between one and two times the gap of an element of the creasing matrix.

[0011] An embodiment of the present invention will now be described by way of example, with reference to the accompanying Figures, in which:-

Figure 1 is a schematic cross-section through a known creasing machine; and

Figure 2 is a schematic cross-section through a creasing machine according to the present invention.

[0012] The known creasing machine illustrated in Figure 1 has a platen 1 which carries a creasing matrix formed of matrix elements 2, 3 which project from the platen 1 and have a small gap 4 therebetween. Above the gap is a creasing rule 5 which is moveable in a direction substantially perpendicular to the surface of the platen 1. In its raised position, the creasing rule stands clear of the creasing matrix whilst in its lower position the creasing rule projects into the gap 4 between the matrix elements 2, 3.

[0013] To produce a crease line in a cardboard sheet 6, the creasing rule 5 is moved to its raised position, and the sheet 6 is moved substantially parallel to the platen 1 until the desired crease line lies between the gap 4 and the creasing rule 5. The creasing rule 5 is then moved sharply into its lowered position, and then to its raised position. A crease is thus produced in the sheet 6.

[0014] Clearly, to obtain a higher throughput in the creasing machine it is necessary to move the cardboard sheet 6 quickly. A problem with this is that the sheet's leading edge 7 can begin to drop, and it is not uncommon for it to strike the nearest matrix element 3, as shown in chain dotted line in Figure 1. Once this happens, that sheet 6 is damaged and can cause the machine to jam. When a jam occurs, the machine must be stopped in order for it to be cleared.

[0015] Figure 2 shows a creasing machine similar to that of Figure 1, but with the addition of a profiled lead strip 10. Similar integers to those shown in Figure 1 have been given the same reference numerals. The lead strip is of an aerodynamic profile and has a curvilinear lead-

ing edge 11 and a thicker end 12 positioned closer to the creasing matrix.

[0016] The lead strip 10 is, in this embodiment, positioned ahead of the creasing matrix by a distance roughly equal to the width of the creasing element 3. Its height is roughly twice that of the creasing element 3. The aerodynamic profile is similar to that of a common aircraft wing.

[0017] The profiled strip 10 has double-sided tape 14 secured to its undersurface which is recessed to receive the tape to ensure that the leading edge of the strip always lies flush with the surface of the platen and does not lift in use of the machine. Thus, the tape extends from the trailing edge of the strip to a position just in-board from the strip leading edge.

[0018] One effect of the lead strip 10 is to affect the air within the boundary layer of the sheet 6. Such air will normally be carried along with the sheet 6 so that it moves. It therefore has a translational velocity component relative to the lead strip 10. As the leading edge 7 of the sheet 6 passes over the lead strip 10, a vortex is created behind the lead strip 10 which raises the leading edge 7 to prevent it striking the matrix element 3. In the event that contact is made, the effect on the sheet leading edge is marginal because of the profile of the strip 10.

[0019] Thus, the likelihood of jams is reduced, and the machine can be run at a significantly higher rate.

[0020] It will of course be appreciated by those skilled in the art that the above described embodiment is purely exemplary of the present invention, and that many variations are possible whilst remaining in the scope of claims 1 - 3.

Claims

1. A creasing machine for imparting a crease to a creasable article, the machine comprising a platen (1), a creasing matrix (2,3) secured to the surface of the platen and upstanding therefrom, and a creasing rule (5) moveable transversely between a position spaced from the creasing matrix (2,3) and a position adjacent or within the creasing matrix; the machine being characterised in that it includes a strip (10) positioned ahead of the creasing matrix and in the path of the article (6) to be creased, the strip (10) having a profile whose leading edge is curvilinear and whose undersurface lies flush with the surface of the platen (1) at all times, the profiled strip acting to deflect an incoming article thereby preventing or minimising contact between the article with an upstanding face of the creasing matrix.
2. A creasing machine as claimed in claim 1 in which the profiled strip (10) is secured to the platen with double-sided tape (14).

3. A creasing machine as claimed in claim 2 in which the undersurface of the profiled strip (10) is recessed to receive the double-sided tape (14), the recessed extending from the rear edge of the strip (10) to a position in board from its leading edge.

Patentansprüche

1. Kerbmaschine zum Einprägen einer Kerbe in einem korbbaaren Gegenstand mit einer Platte (1), mit einer auf der Oberfläche der Platte festgelegten und von dieser vorstehenden Kerbmatrix (2, 3) und mit einem Kerblineal (5), welches quer beweglich ist zwischen einer Stellung, in der es von der Kerbmatrix (2, 3) im Abstand liegt und einer Stellung, in der es benachbart zur Kerbmatrix oder in dieser befindlich ist, wobei die Maschine dadurch gekennzeichnet ist, daß sie eine Leiste (10) aufweist, die vor der Kerbmatrix und im Bewegungspfad des einzukerbenden Gegenstandes (6) angeordnet ist, daß die Leiste (10) ein Profil besitzt, dessen Vorderrand gekrümmt ist und dessen Unterseite mit der Oberfläche der Platte (1) immer fluchtet, und daß die Profilleiste eine Auslenkung eines ankommenden Gegenstandes bewirkt und dadurch eine Berührung zwischen dem Gegenstand mit einer vorstehenden Fläche der Kerbmatrix verhindert oder vermindert.
2. Kerbmaschine nach Anspruch 1, bei welcher die Profilleiste (10) auf der Platte mit einem doppelseitigen Klebeband (14) festgelegt ist.
3. Kerbmaschine nach Anspruch 2, bei welcher die Unterseite der Profilleiste (10) eine Ausnehmung aufweist, um das doppelseitige Klebeband (14) aufzunehmen, wobei sich diese Ausnehmung vom Hinterrand der Leiste (10) nach einer Stelle erstreckt, die im Inneren der Leiste im Abstand zu ihrem Vorderrand liegt.

Revendications

1. Une machine de rainage pour créer une rainure dans un article à rainer, la machine comprenant une platine (1), une matrice de rainage (2,3) fixée à la surface de la platine et faisant saillie à partir de celle-ci, et un filet raineur (5) mobile transversalement entre une position écartée de la matrice de rainage (2,3) et une position adjacente ou à l'intérieur de la matrice de rainage; la machine étant caractérisée en ce qu'elle comporte une bande (10) positionnée à l'avant de la matrice et sur le trajet de l'article (6) à rainer, la bande (10) ayant un profil dont le bord d'attaque est curvilinéaire et dont la surface intérieure est de niveau avec la surface de la platine (1) à tout moment, la bande profilée agissant pour dé-

fléchir un article lorsqu'il arrive, empêchant ainsi ou réduisant au minimum le contact entre l'article avec une face en saillie de la matrice de rainage.

2. Une machine à rainer selon la revendication 1 dans laquelle la bande profilée (10) est fixée à la platine au moyen d'une bande (14) adhésive double-faces. 5

3. Une machine à rainer selon la revendication 2 dans laquelle la surface inférieure de la bande profilée (10) comporte un creux pour recevoir la bande (14) adhésive double-faces, ce creux s'étendant depuis le bord arrière de la bande (10) vers une position en dedans à partir de son bord d'attaque. 10
15

20

25

30

35

40

45

50

55

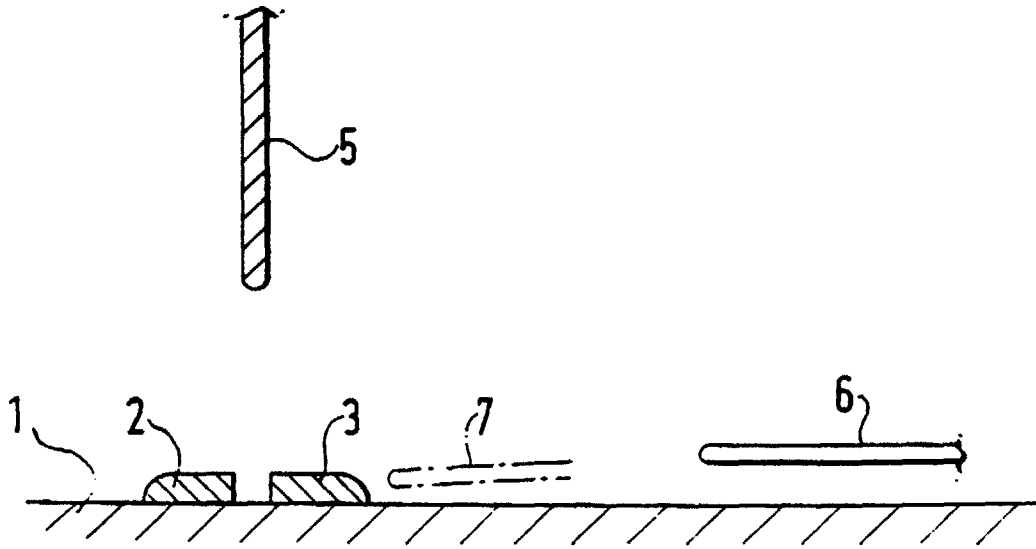

Fig.1.

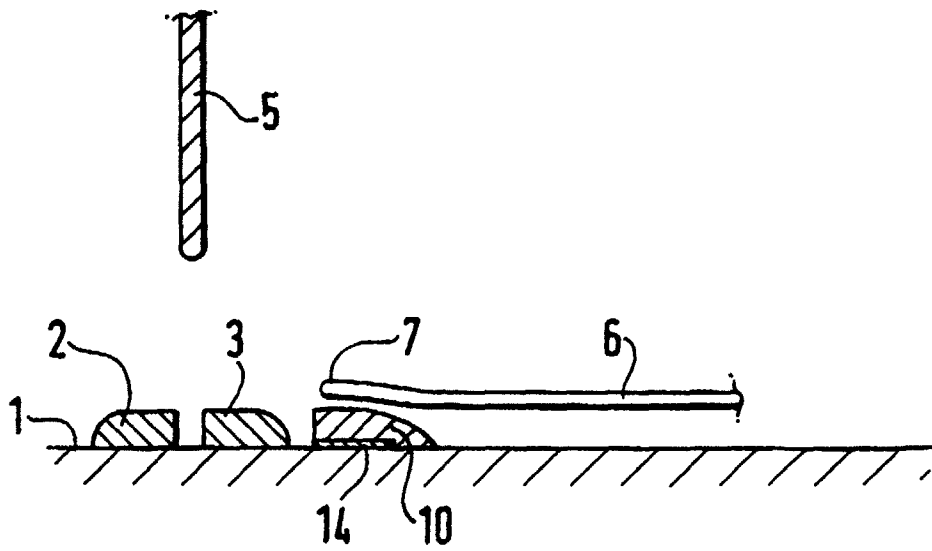

Fig.2.