

A. H. DYSON.  
 CALLING DEVICE FOR ELECTRICAL EXCHANGE SYSTEMS.  
 APPLICATION FILED FEB. 16, 1906.

1,000,902.

Patented Aug. 15, 1911.

2 SHEETS-SHEET 1.

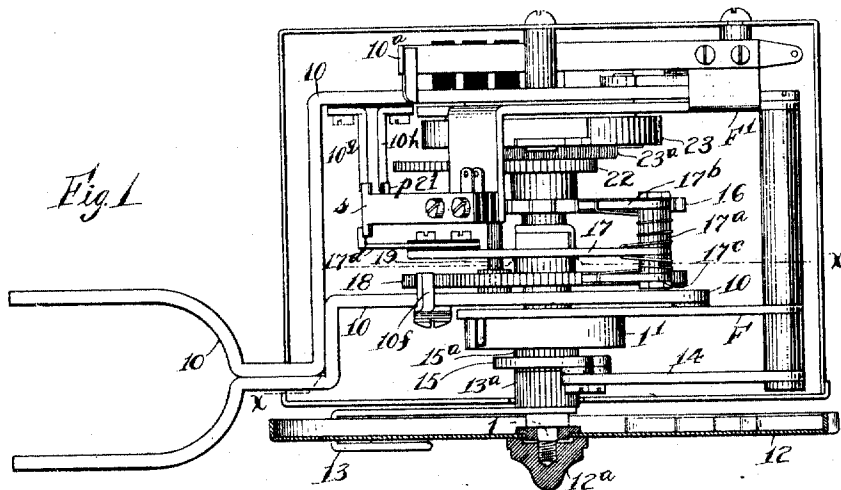

Fig. 1

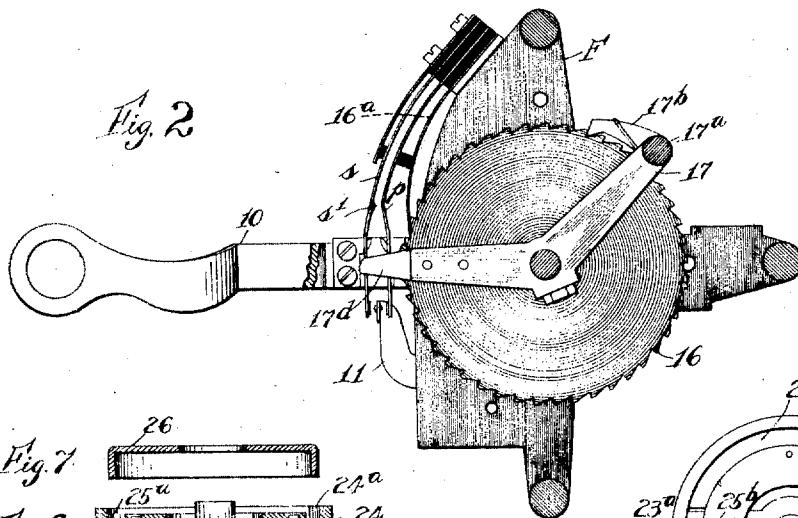

Fig. 2

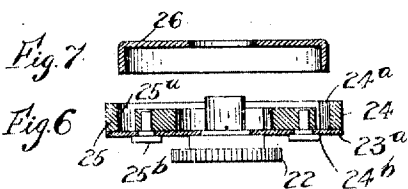

Fig. 6

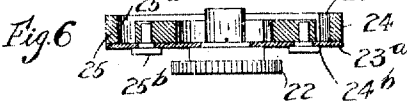

Fig. 7

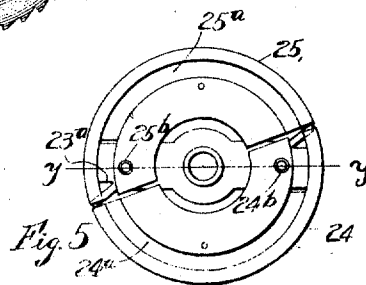

Fig. 5

Witnesses  
 G. E. Mueller.  
 L. J. Kellogg

Inventor  
 Alfred H. Dyson

A. H. DYSON.  
 CALLING DEVICE FOR ELECTRICAL EXCHANGE SYSTEMS.  
 APPLICATION FILED FEB. 16, 1906.

1,000,902.

Patented Aug. 15, 1911

2 SHEETS—SHEET 2.

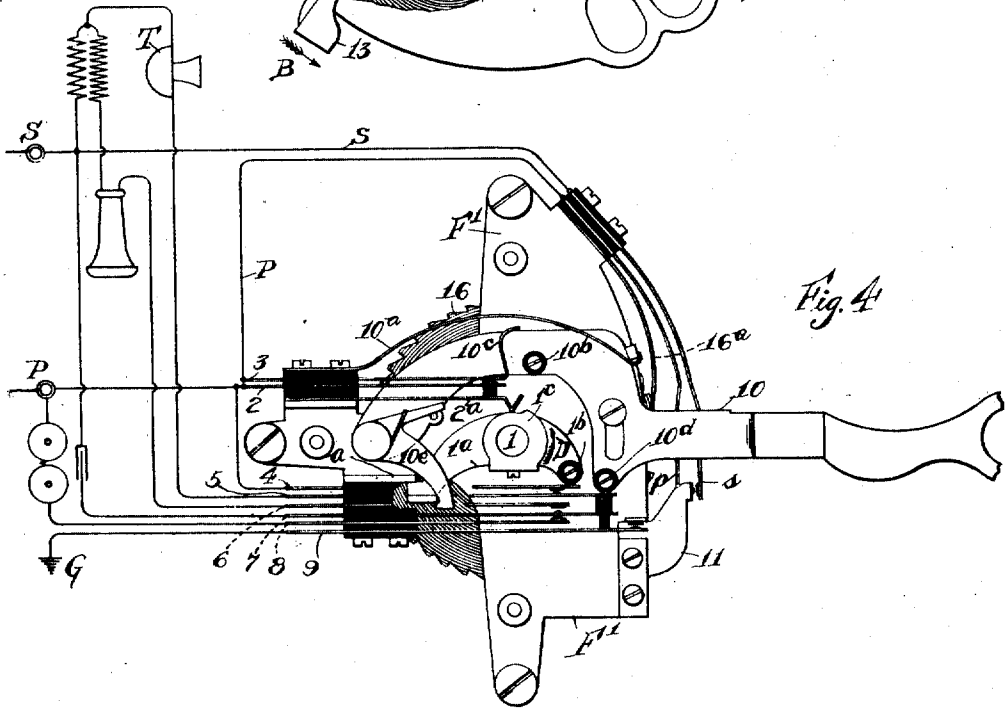
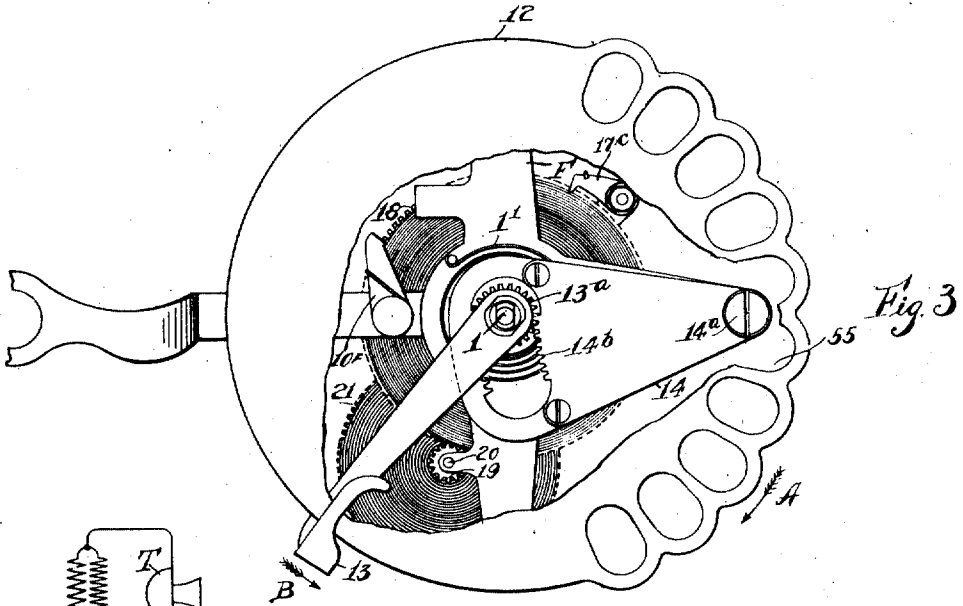

Witnesses  
 G. E. Muller  
 L. D. Kellogg

Inventor  
 Alfred H. Dyson

# UNITED STATES PATENT OFFICE.

ALFRED H. DYSON, OF CHICAGO, ILLINOIS, ASSIGNOR, BY MESNE ASSIGNMENTS, TO  
KELLOGG SWITCHBOARD & SUPPLY COMPANY, A CORPORATION OF ILLINOIS.

CALLING DEVICE FOR ELECTRICAL EXCHANGE SYSTEMS.

1,000,902.

Specification of Letters Patent. Patented Aug. 15, 1911.

Application filed February 16, 1906. Serial No. 301,472.

To all whom it may concern:

Be it known that I, ALFRED H. DYSON, residing in Chicago, county of Cook, and State of Illinois, have invented new and useful Improvements in Calling Devices for Electrical Exchange Systems, of which the following is a specification.

My invention relates to calling devices for electrical exchange systems and has for its object the provision of an improved structure for transmitting signaling currents to exchange mechanisms.

The calling device of my invention is essentially an electro-mechanical number-recording machine, the numbers being recorded by means of electro-magnetic switching devices at the exchange.

In recorders in general it has been found convenient to employ a movable member provided with adjacent finger holds, one for each number to be recorded, associated with which is a stopping device to limit the movement of the said member according to the finger hold selected. In the employment of a device of this character for exchange work, rapidity of operation is of the essence, and my invention has for its more particular object, the arrangement of a structure giving a very rapid operation.

The known recorders of the character above referred to have a single stopping device immovably related to the movable member and each time the device is operated the selected finger hold must be brought around to this point. The finger holds must be sufficiently large to readily admit of a firm grasp by the finger and must be properly spaced so as not to be too crowded; hence the number whose finger hold is farthest from the stopping point requires considerable movement of the device to record it.

Briefly stated, my invention, to the end of reducing the extent of movement of the member, provides for a plurality of stopping places and this is accomplished by a second movable member linked to that containing the finger holds by a suitable arrangement of gears and racks, so as to come toward the finger and meet it when the device is operated. I am thereby enabled to reduce the required movement of the finger

for the recording of each number by approximately one half.

The exchange systems in connection with which my invention may be used are provided with metallic circuit lines and the exchange switching devices are operated responsive to sets of current impulses transmitted over the two line limbs separately by connecting them with a third independent conductor. The usual sequence of current impulses consists of a plurality of impulses sent over a limb P to record a certain number, and a single impulse sent over the other limb S, after the transmission of the last impulse of the plurality mentioned, for the purpose of setting in train of motion auxiliary apparatus to prepare for the transmission of the next number. Such exchange systems form no part of my present invention and will therefore not be particularly described in this application, as several varying forms thereof are in wide commercial use in the United States.

Referring to the drawings, in Figure 1 I illustrate a top view of the preferred embodiment of my invention. In Fig. 2 I show a side view thereof on section line  $x-x$  of Fig. 1. In Fig. 3, I show a front elevation thereof having a portion of the finger dial cut away. In Fig. 4, I illustrate a rear elevation of the device, the operating springs thereof being connected to a known form of telephone substation circuits. In Fig. 5 I illustrate a form of governor employed in connection with the device. Fig. 6 is a sectional view thereof on line  $y-y$  of Fig. 5. Fig. 7 illustrates a friction member for said governor.

Referring first to Figs. 1 and 3, 1 is the main shaft journaled to the frame plates F and F'. Rigidly attached to the front end of shaft 1 by screw 12<sup>a</sup> is the dial 12 provided with 10 adjacent finger holds. Fastened to the shaft 1 is gear 15<sup>a</sup> meshing with rack 15, the latter being fastened by two screws to a second rack 14<sup>b</sup> cut in the lever arm 14, pivoted at 14<sup>a</sup>. Loosely turning on the shaft 1 and meshing with rack 14<sup>b</sup> is a second gear 13<sup>a</sup> to which is fastened finger lever 13. The moving of the finger dial 12 in the direction of the arrow A (Fig.

3) carrying with it the shaft 1 and gear 15<sup>a</sup> operates by racks 15 and 14<sup>b</sup> to transmit motion to lever 13 in the direction indicated by arrow B so that 13 moves substantially a distance equal to that moved by the finger, to meet it in the selected hold. Attached to shaft 1 and frame F is spring 1' causing a reverse clockwise movement of shaft 1 after dial 12 has been rotated and released. Shaft 1 also carries rigidly attached to it the lever 17 whose left extremity carries an arm 17<sup>a</sup> arranged to contact with spring *s* and whose right extremity carries the stud 17<sup>a</sup> to which are pivoted the two pawls 17<sup>b</sup> and 17<sup>c</sup>. These pawls are held by their associated springs in engagement respectively with the impulse wheel 16 and the gear-wheel 18, loosely mounted on shaft 1, the arrangement of both pawls with respect to the teeth of their wheels being similar to the relation of pawl 17<sup>b</sup> to wheel 16 as disclosed in Fig. 2, namely such that when by the movement of shaft 1, lever 17 is clockwise rotated, the pawls 17<sup>b</sup> and 17<sup>c</sup> slip over the teeth without causing movement of the wheels themselves, whereas upon a reverse clockwise movement of the shaft they engage the gear teeth and cause a corresponding movement of the said wheels 16 and 18. Impulse wheel 16 has in mechanical contact with it a stiff spring 16<sup>a</sup> (Fig. 2) connected to spring *p*; on a reverse clockwise movement of wheel 16, spring 16<sup>a</sup> rides over successive teeth of the wheel causing spring *p* to engage contact plate 11, once for each tooth ridden over. The lug 17<sup>a</sup> attached to the lever 17, passes, on clockwise movement of the lever, past the projection *s'* of the spring *s* on the under side thereof, while on the return of the lever to its normal position shown, lug 17<sup>a</sup> passes on the outer side of *s'*, thereby pressing spring *s* to engage the contact plate 11. The gear 18 meshes with the small gear 20 (Fig. 3) attached to the auxiliary shaft 20, which is journaled to plates F and F'. Fastened to shaft 20 is a large gear 21 meshing with the gear 22 which with the attached governor 23 is loosely mounted on shaft 1. This arrangement is to link the lever 17 by its pawl 17<sup>c</sup>, and consequently the shaft, with the governor and its friction member so as to secure an even speed of impulse wheel 16.

In Figs. 5 and 6 the governor is shown consisting of two segments 24 and 25 pivoted at 24<sup>b</sup> and 25<sup>b</sup> respectively to the cross bar 23<sup>a</sup> which fits loosely on the shaft. The slots 24<sup>a</sup> and 25<sup>a</sup>, cut in segments 24 and 25 receive the circular friction member 26 which fastens rigidly to frame F'. Cross bar 23<sup>a</sup> attached to gear 22 (Fig. 6), when rotated on movement of the gear throws the segments 24 and 25 outwardly about pivots 24<sup>b</sup> and 25<sup>b</sup> to clutch the friction member 26. The hook lever 10 is pivoted to frame plates

F and F' as shown in Figs. 1 and 4 and carries a pawl 10<sup>c</sup> (Figs. 1 and 3) adapted to engage the teeth of gear 18, operating with respect thereto in a manner similar to that of pawl 17<sup>c</sup>, whereby the descent of the hook lever upon the replacing of the receiver is brought under control of the governor 23. Screwed to hook lever 10 are two lugs 10<sup>s</sup> and 10<sup>b</sup> (Fig. 1) arranged on upward movement of the hook lever to pass inside of their associated extensions of springs *p* and *s*, while on a subsequent downward stroke of the lever they pass on the outer sides of said extensions to press the said springs inwardly to simultaneously contact with plate 11. When lugs 10<sup>s</sup> and 10<sup>b</sup> pass beyond the associated extensions of springs *p* and *s*, the said springs by their tension disengage contact plate 11.

Referring now to Fig. 4, P and S are the two limbs of the telephone line extending to the substation, and being normally united through the customary call bell and condenser via contact between springs 8 and 7. Limb P is also connected to spring 4 whose associated contact spring 5 is, connected through transmitter T and the primary winding of the induction coil to limb S. Connected to limb P is spring 2 mechanically bound to lever 2<sup>a</sup>, and in electrical association with spring 3 extending to spring *p*. Limb S extends to spring *s* and, through the windings of the induction coil and the receiver, to spring 6, which when engaged by its associated spring 7 connects the receiver with the condenser in talking relation with the line. Associated with contact plate 11 and adapted to be placed in electrical connection therewith is the spring 9 which is connected to a third conductor which may be earth, as indicated at G. The hook lever 10 is shown in its normal position as if the receiver were supported by it. Its spring 10<sup>a</sup> raises the lever upward upon the removal of the receiver, the bushing 10<sup>d</sup> of insulating material then removing tension from springs 5, 7 and 9, connected mechanically by the insulating studs shown, whereby the said springs move to their alternate positions engaging springs 4, 6 and contact plate 11 respectively. A second bushing 10<sup>b</sup> fastened to lever 10 engages extension 10<sup>c</sup> of spring 3 as the lever 10 completes its upward movement, to open contact 2—3. Fastened pivotally to lever 10 is the pawl 10<sup>c</sup>, normally held by its spring in interlocking relation with an arm 1<sup>a</sup> attached to shaft 1 whose bushing 1<sup>b</sup> normally holds spring 4 in the position shown. The pawl 10<sup>c</sup> locks the shaft from rotation until the receiver is removed, and being mounted on lever 10 so as to have a relatively slight movement as compared with bushing 10<sup>d</sup>. Contact 4—5 will on the removal of the receiver be closed before the shaft 1 will be rendered movable by

the disengagement of pawl 10<sup>a</sup> from arm 1<sup>a</sup>. This is to send a preliminary switching impulse metallicly through limbs P and S. A cam 1<sup>c</sup> on arm 1<sup>a</sup> is adapted, when the shaft is rotated in the direction of the arrow D, to lift spring 2<sup>a</sup> and thereby spring 2 to engage spring 3.

Having described the mechanical arrangement of the calling device of my invention, its method of use will be explained in the following narrative of operation.

The switching operations require to be executed by the calling device are; that on the removal of the receiver, limbs P and S shall be conductively united before the finger dial 12 shall be operated; that contact between limb P and plate 11 shall be made and broken a number of times depending on the selected finger hold of dial 12; that contact shall be made and broken a single time between limb S and plate 11 after the last connection between P and 11; that the conductively united condition of limbs P and S, interrupted during the operation of dial 12, shall be reestablished on the return of the dial to normal; and that on the replacing of the receiver, springs *p* and *s* shall simultaneously be for a moment connected to contact plate 11. A calling subscriber first removes his receiver from hook lever 10, which moves upward whereupon spring 9 connects third conductor G to plate 11, spring 7 disconnects the condenser from the call bell and connects it with the receiver circuit, and spring 5 conductively unites limbs P and S through contact 4—5 and transmitter T. Immediately thereafter, as lever 10 ascends pawl 10<sup>a</sup> unlocks shaft 1 rendering it rotatable by finger dial 12, and contact 2—3 is opened disconnecting spring *p* and limb P. Supposing the subscriber desires to record the number 5, he inserts his finger in finger hold 55 of dial 12, the fifth hold from below, and rotates the dial (which carries with it shaft 1) in the direction of arrow A, until finger lever 13, moved in the direction of arrow B, by its described gear combination, meets his finger. Lever 17 is thereby moved in a clockwise rotary direction until its pawl 17<sup>b</sup> has passed over eight teeth of impulse wheel 16, three more than the units of the number to be recorded. Arm 1<sup>a</sup> with its cam 1<sup>c</sup> (Fig. 4) turns with the dial and shaft as indicated by arrow D, bushing 1<sup>b</sup> removing tension from spring 4 which disengages spring 5 to disunite limbs P and S which remain disunited until the shaft reaches normal. Cam 1<sup>c</sup> as pawl 17<sup>b</sup> passes over the fourth tooth of impulse wheel 16, lifts with its raised portion spring 2<sup>a</sup> to place spring 2 in engagement with spring 3, whereby *p* and P are connected. The subscriber now removes his finger from hold 55 and the shaft 1 and dial 12, by the influence of spring 1<sup>a</sup> are rotated in a re-

verse clockwise direction. Lever 17 and its pawls 17<sup>b</sup> and 17<sup>c</sup> are carried with the shaft, pawl 17<sup>b</sup> engaging the last tooth over which it was moved as before described, and moving impulse wheel 16, which by its spring 70 16<sup>a</sup> connected to spring *p*, causes the said spring *p* to be connected to contact plate 11, eight separate times. Limb P of the line is thereby connected through contacts 2—3, *p*—11 and 11—9 to the third conductor G 75 five separate times and would be so connected eight times were it not for the fact that, just before the sixth closing of contact *p*—11, cam 1<sup>c</sup> reaches a point where it allows contact 2—3 to be opened, thereby disconnecting *p* and P. After 2—3 is opened and 80 simultaneously with the seventh contact between *p* and 11, arm 17<sup>a</sup> (Figs. 1 and 2) passes outside of spring *s* pressing it inwardly to engage plate 11 whereby limb S 85 is momentarily and for a single time connected to third conductor G through contacts *s*—11 and 11—9. The return movement of the shaft caused by the eighth tooth passed over by pawl 17<sup>b</sup>, does not cause the connection of either line limb to the third conductor, but closes contact 4—5 establishing the talking circuit and brings arm 1<sup>a</sup> 90 against stop *a*, which arrests the movement of the shaft 1. For any number to be transmitted, the arrangement is such that pawl 17<sup>b</sup> will pass over three teeth of wheel 16 more than the digits of the number so that after the last impulse over limb P, one tooth causes movement to open contact 2—3, another to close and open contact *s*—11, the 100 third to bring the dial to normal and close contact 4—5. Additional numbers, one after the other, may be recorded by successive similar operations of dial 12 to complete in the usual manner by means of the central office apparatus connection from the calling line to the desired called line. Upon the replacing of the receiver on hook lever 10 lugs 10<sup>a</sup> and 10<sup>b</sup> (Fig. 1) simultaneously 110 connect springs *p* and *s* to contact plate 11 and (contact 3—2 being closed as lever 10 begins to descend) limbs P and S are simultaneously connected to the third conductor G which in accordance with the known 115 methods of operation will cause the lines to be disconnected. As the lever reaches normal, springs 5, 7 and 9 assume their normal positions shown, under the influence of bushing 10<sup>a</sup>, the call bell and condenser being thereby placed in bridge of limbs P and S, while pawl 10<sup>a</sup> hooks over arm 1<sup>a</sup> and prevents movement of dial 12 and shaft 1 until after the receiver is again removed, as before described. 125

I claim:—

1. A calling device comprising a movable member provided with adjacent finger holds, a second movable member linked with the first, said members being arranged to limit 130

the movement each of the other according to selected finger holds and mechanism actuated responsive to movements of said members to transmit current impulses corresponding to the selected holds.

2. A calling device comprising a lever provided with adjacent finger holds, a second lever traveling in a direction opposite to the first on movement thereof to limit the travel of the first and an impulse transmitter actuated on movement of said levers.

3. In a calling device, the combination with a traveling member provided with adjacent finger holds, of a second member, a gear adapted on movement of the first member to effect an opposed movement of the second member, and an impulse transmitter actuated on movement of said members.

4. A calling device comprising a lever provided with a plurality of adjacent finger holds; an impulse transmitter actuated on movement thereof to transmit impulses corresponding to the selected holds, and a movable arm actuated on movement of the lever for stopping the lever in a plurality of positions according to the selected holds.

5. A calling device comprising a shaft, an impulse transmitter operated responsive to the actuation thereof, a movable member provided with adjacent finger holds for actuating said shaft, a second movable member, and a gear linking said second member with the shaft adapted on movement of the first member to cause an opposed movement of the second to limit the movement of the first.

6. In combination in a calling device for an electrical exchange, a pair of line limbs, a movable finger member, a cooperating movable stop, an impulse transmitter actuated on movement thereof adapted to connect the line limbs in predetermined fashion with a third conductor, a hook lever normally interlocking with said finger member to prevent movement thereof, means for uniting said line limbs in metallic circuit actuated on the removal of the receiver from the hook lever, and mechanism controlled by the hook

lever for thereafter unlocking said finger member.

7. A calling device comprising a member provided with adjacent finger-holds, a stop movable with said member for limiting the movement of said member, and an impulse transmitter actuated on the movement of said member, said stop having a movement different in direction from that of said member.

8. A calling device comprising impulse transmitter mechanism, a stop movable in response to the operation of said mechanism and means cooperating with said stop to determine the numbers of impulses transmitted on actuation of said device.

9. A calling device comprising manually actuated impulse mechanism, a stop adapted to be adjusted to a plurality of positions in response to the operations of said mechanism, and cooperating means for said stop.

10. A calling device including an impulse transmitter, and an adjustable stop movable in response to the operation of said device to control the extent of its operation.

11. A calling device comprising a movable member having a plurality of adjacent finger holds, a second oppositely movable member for engaging the finger to limit the movement of said first member, and mechanism for transmitting impulses corresponding to said finger holds.

12. A calling device comprising a movable dial pivoted at its center and having a circular row of finger holds near its periphery, a finger lever pivoted inward from said finger holds, and being adapted to move oppositely to said dial and operative to engage the finger to limit the movement of said dial, and mechanism for transmitting impulses corresponding to said finger holds.

In witness whereof, I have hereunto subscribed my name this 13th day of February 1906.

ALFRED H. DYSON.

Witnesses:

G. E. MUELLER,  
H. C. OLMSTEAD.