

(19) World Intellectual Property Organization
International Bureau



(43) International Publication Date
2 April 2009 (02.04.2009)

PCT

(10) International Publication Number
WO 2009/042744 A1

- (51) International Patent Classification:
C10J 3/48 (2006.01) C10J 3/46 (2006.01)
- (21) International Application Number:
PCT/US2008/077617
- (22) International Filing Date:
25 September 2008 (25.09.2008)
- (25) Filing Language: English
- (26) Publication Language: English
- (30) Priority Data:
11/860,807 25 September 2007 (25.09.2007) US
11/860,815 25 September 2007 (25.09.2007) US
- (71) Applicant: NEW YORK ENERGY GROUP, INC.
[—US]; 250 Finney Drive SW, Huntsville, AL 35824 (US).
- (72) Inventors: DUCA, William, J.; 648 Squirrel Hill Drive, Boardman, OH 44512 (US). BUCHER, Keith, R.; 7746 Donegal Drive SE, Huntsville, AL 35802 (US). INGRAM, Charles, B.; 160 Barrington Place, Rockwood, TN 37854

- (US). THOMPSON, David, C.; 112 Chatham Circle, Madison, AL 35758 (US).
- (74) Agent: BROWNING, Brandon, C.; Maynard Cooper & Gale, PC, 1901 Sixth Avenue North; Ste. 24, Birmingham, AL 35203-2618 (US).
- (81) Designated States (unless otherwise indicated, for every kind of national protection available): AE, AG, AL, AM, AO, AT, AU, AZ, BA, BB, BG, BH, BR, BW, BY, BZ, CA, CH, CN, CO, CR, CU, CZ, DE, DK, DM, DO, DZ, EC, EE, EG, ES, FI, GB, GD, GE, GH, GM, GT, HN, HR, HU, ID, IL, IN, IS, JP, KE, KG, KM, KN, KP, KR, KZ, LA, LC, LK, LR, LS, LT, LU, LY, MA, MD, ME, MG, MK, MN, MW, MX, MY, MZ, NA, NG, NI, NO, NZ, OM, PG, PH, PL, PT, RO, RS, RU, SC, SD, SE, SG, SK, SL, SM, ST, SV, SY, TJ, TM, TN, TR, TT, TZ, UA, UG, US, UZ, VC, VN, ZA, ZM, ZW.
- (84) Designated States (unless otherwise indicated, for every kind of regional protection available): ARIPO (BW, GH, GM, KE, LS, MW, MZ, NA, SD, SL, SZ, TZ, UG, ZM, ZW), Eurasian (AM, AZ, BY, KG, KZ, MD, RU, TJ, TM),

[Continued on next page]

(54) Title: GASIFIER

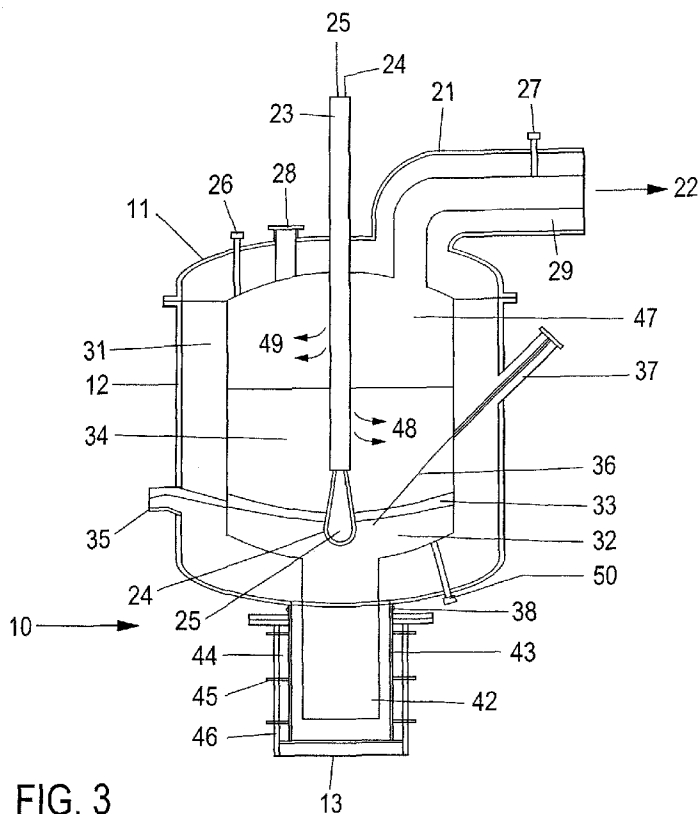

(57) Abstract: A gasifier for producing synthesis gas from a widely varying feedstock of waste and natural fuels, the gasifier including an induction furnace, a molten bed and slag reaction chamber mounted on top of the induction furnace, an opening fluidly connecting the interior of the induction furnace and the inside bottom of the reaction chamber, the reaction chamber further containing a froth and off-take reaction zones above the molten metal and slag, and a lid at the top of the reaction chamber for enclosing the reaction chamber and collecting the heat and fuel gas produced therein.

WO 2009/042744 A1



European (AT, BE, BG, CH, CY, CZ, DE, DK, EE, ES, FI, FR, GB, GR, HR, HU, IE, IS, IT, LT, LU, LV, MC, MT, NL, NO, PL, PT, RO, SE, SI, SK, TR), OAPI (BF, BJ, CF, CG, CI, CM, GA, GN, GQ, GW, ML, MR, NE, SN, TD, TG).

Published:

— *with international search report*

GASIFIER

Technical Field

The present invention relates to a gasifier for producing synthesis gas, and in particular to a molten bed reaction chamber for producing a high quality synthesis gas from a widely varying feedstock of waste and natural fuels, the reaction chamber being mounted on top of and in fluid with communication with an
5 induction furnace.

Background Art

Conventional gasification is a process that converts carbonaceous materials, such as coal, petroleum, petroleum coke or biomass, into carbon monoxide,
10 hydrogen and carbon dioxide. In a conventional gasifier, the carbonaceous material undergoes three processes including pyrolysis, combustion and gasification. During the pyrolysis process, the carbonaceous material heats up, volatiles are released and char is produced. The process is dependent on the properties of the carbonaceous material and determines the structure and composition of the char,
15 which will then undergo gasification reactions. The combustion process occurs as the volatile products and some of the char reacts with oxygen to form carbon dioxide and carbon monoxide, which provides heat for the subsequent gasification reactions. The gasification process occurs as the char reacts with carbon dioxide and steam to produce carbon monoxide and hydrogen. The resulting gas is called
20 syngas. Syngas is typically combusted in a gas turbine, and the heat is used to produce steam to drive a steam turbine.

There are four basic types of gasifiers operating today including fixed bed systems, fluidized bed systems, entrained flow systems and molten bed systems. In a fixed bed reactor, a reactive gas or gases are passed through a fixed bed of
25 feedstock in a co-current or counter current flow. The fixed bed consists of carbonaceous fuel (e.g. coal or biomass) through which a "gasification agent" (steam, oxygen and/or air) flows in a co-current or counter-current configuration. The ash is either removed dry or as a slag. The nature of a fixed bed gasifier means that the fuel must have high mechanical strength and must be non-caking so that it

will form a permeable bed. Thus, certain feedstocks such processed municipal solid waste, biosolids, ground coal and certain types of biomass are not suited for use in fixed bed reactors. This is particularly true when moisture is present.

In a fluidized bed reactor, the pressure drop of the gasifying reactants is adjusted so that the feedstock is lifted or suspended by the gaseous phase. In particular, the carbonaceous fuel is fluidized in oxygen (or air) and steam. The ash is removed dry or as heavy agglomerates that defluidize. The temperatures are relatively low in dry ash gasifiers, so the fuel must be highly reactive; low-grade coals are particularly suitable. Fluidized bed gasifiers are most useful for fuels that form highly corrosive ash that would damage the walls of slagging gasifiers. Biomass fuels generally contain high levels of corrosive ash.

In an entrained bed reactor the solid particulate feedstock are carried or "entrained" through the reactor by the reacting gases. In particular, a dry pulverized solid, an atomized liquid carbonaceous fuel or a fuel slurry is gasified with oxygen in co-current flow. The gasification reactions take place in a dense cloud of very fine particles. Most coals are suitable for this type of gasifier because of the high operating temperatures and because the coal particles are well separated from one another. The fuel particles must be much smaller than for other types of gasifiers. This means the fuel must be pulverized, which requires somewhat more energy than for the other types of gasifiers. It also means that feedstocks such as processed municipal solid waste, certain biomass, spent tires and several types of industrial wastes are not well suited for this type of gasifier.

In a molten bed reactor higher heat value feedstock (primarily coal) is injected into a molten bath of iron, salt or coal ash contained within a reactor. A reactive gas such as oxygen, steam and/or carbon dioxide is injected into the vessel to control the rate of reaction within the reactor. A shortcoming of current molten bed gasifiers is the inability to process low heat value feedstocks and thus widely varying feedstocks. Often this is because low heat value feedstocks such as municipal solid waste, certain biomass wastes and some household and industrial wastes, when introduced into a molten bath can consume rather than produce heat

thus limiting the efficiency of the reactor and possibly endangering the continuity of the process itself.

An exemplary molten bed reactor is described in U.S. Patent No. 4,649,867 including a substantially cylindrical vessel which has a substantially oblong section and lateral walls and a bottom wall which are lined with a refractory lining. An
5 orifice for discharging the bath of liquid metal and an orifice for discharging slag supernatant on the bath of liquid metal are provided. In addition, a dome is positioned in a sealed manner on the vessel having in its upper part in the vicinity of one of the ends of the vessel a sealed box for introducing an injecting branch. An
10 orifice is provided in the upper part of the vessel for exhausting the gases produced. A roughly central orifice for introducing additional elements is also provided in the upper part.

Another exemplary molten bed reactor is described in U.S. Patent No. 4,865,626. This patent discloses a process for producing gas containing carbon
15 monoxide and hydrogen gas including introducing lump coal by means of a down pipe and one or more inlets in a gasifier head into a gasifier having a fluidized bed region and a free board space or killing region. The coal passes through the killing region into the fluidized bed region and is gasified therein with the aid of oxygen or oxygen-containing gas supplied from an oxygen source and blown into a region
20 below the fluidized bed region. When the coal passes through the free board space it is spontaneously dried and degassed in an endothermic reaction that results in a temperature drop in the free board space and ensures that only coal constituents bringing about a high gasification temperature enter the lower part of the fluidized bed region.

25 **Disclosure of the Invention**

The motivating object of the present invention was the need for a superior waste to energy conversion process allowing for increased fuel flexibility. Specifically, for this invention, the goal is to efficiently and economically produce a
30 high quality synthesis gas from low heat value, widely varying feedstock. Such feedstock can include waste materials contaminated with inorganics as well as low grade natural fuels and industrial by-products. The resulting synthesis gas is of

sufficient quality to allow production of electrical power, refining of Fischer-Tropsch liquids, production of methanol or the separation of industrial grade hydrogen. In addition, the present invention provides for improved environmental impact and clean and more environmentally friendly energy production while improving upon current industrial conversion efficiencies. Further, the present invention provides a major new source of energy from material that is currently considered useless, hazardous or not worth harvesting.

By fuel flexibility it is meant that the gasifier of the present invention is capable of handling a broad range of wastes from municipal waste, medical waste, biomass to bio-solids, spent tires, and industrial/agriculture waste. This includes a wide range of natural fuels and waste fuels. Further, the gasifier of the present invention can process solids, liquids and gaseous feed streams simultaneously in a single reactor, as well as low heat value feed (3,800 BTU/lb) as raw material. Additionally, the gasifier can tolerate a large content of in-organics and contaminants in the carbonaceous feedstock.

By efficiency and economics it is meant that the gasifier exhibits a high thermal conversion efficiency of about 58% to about 65% while operating at ambient pressure, using no air and efficiently using oxygen. It also means that the gasifier can process large quantities (up to 700 tons per day) of varying feedstock in a single reactor vessel. Further, the gasifier can maintain an exothermic reaction state, thus requiring minimal external heat assist, and generate high quality synthesis gas (250 – 350 BTU/scf) with a low particulate level.

By environmental impact it is meant that the gasifier produces no char, minimal ash, no tar, no oils, no phenols and no ammonia while producing useable by-products such as siliceous slag and pig iron. The gasifier can also efficiently and safely process high sulfur and contaminated coal and several types of industrial and household hazardous waste. Further, the gasifier can recycle and dissociate polluting exhaust gases and green house gases such as carbon dioxide, dioxins, furans, volatiles organic gaseous compounds, nitrous oxides and the like.

In order to meet the objects of the invention there is provided a molten bed reactor or gasifier including reaction chamber, for the production and collection of a

fuel gas, mounted on top of, in fluid communication with and removed from a furnace. Preferably, the furnace is an induction furnace, and more preferably a coreless induction furnace, although a channel induction furnace can be used. The purpose of the furnace is to provide the reaction chamber with a constant source of molten metal, maintain the molten metal at a desired temperature, especially when synthesis gas production within the reaction chamber becomes endothermic due to the presence of low heat value feed, and impart vertical stirring of the molten metal within the reaction chamber for providing efficient conversion of carbonaceous fuel to carbon monoxide and hydrogen gas. Until now, induction furnaces were used primarily for batch processes involving melting and alloying metals.

Brief Description of Drawings

FIG. 1 is a front elevational view of a gasifier in accordance with a preferred embodiment of the present invention.

FIG. 2 is a side elevational view of the gasifier of FIG. 1.

FIG. 3 is a vertical sectional view of the gasifier of FIG. 1.

FIG. 4 is a vertical sectional view of the gasifier of FIG. 1 showing the chemical reactions that take place within specific locations within the gasifier during gasification.

FIG. 5 is a front elevational view of a gasifier in accordance with another preferred embodiment of the present invention.

FIG. 6 is a bottom plan view the gasifier of FIG. 5.

Best Mode for Carrying Out Invention

FIGS. 1 through 4 illustrate a gasifier 10 in accordance with a preferred embodiment of the present invention. FIGS. 5 and 6 illustrate a gasifier 100 in accordance with another preferred embodiment of the present invention. Like portions of gasifier 10 share like numbering with gasifier 100.

The present invention is directed to an integrated, multi-stage gasification system designed to maximize the production of synthesis gas from a widely ranging continuous feed stream of both organic and inorganic material. Specifically, seven distinct hardware sections are integrated into a continuous, interactive process designed to gasify solid, liquid and gaseous hydrocarbon material simultaneously.

This is done in the presence of inorganic material which would otherwise disrupt a normal gasification process. The feed stream material includes, but is not limited to the mixed waste and natural fuels material of Table 1.

Table 1

SOLIDS		LIQUIDS		GASES	
Raw Waste Material	Process By-Products	Raw Waste Material	Process By-Products	Raw Waste Material	Process By-Products
Municipal Solid Waste (MSW)	Waxes	Paints	Waxes	Landfill Gas	Light Propane Gas (Refineries)
Medical Waste	Glycerins	Vegetable Oil	Glycerins	Sewage Gas	Carbon Dioxide
Household Hazardous Waste (HHW)	Contaminated Carbon	Mineral Oil	Petro-Chemicals	Contaminated Water Vapor	Coke Oven Gas
Spent Tires	Contaminated Filters	Contaminated Fuels	Bottom Oil	Hydrogen Sulfide	Digester Gas
Biomass	Petroleum Coke	Industrial Solvents	Contaminated Fuels		
Bio-solids	Construction Materials	HHW	Gasifier Oils		
Low Sulfur Coal	Tars		Poly Chlorinated Butylenes		
Brown Coal	Asphalt				
High Sulfur Coal	Agricultural Waste				

Each hardware section, or process stage, is designed to accommodate a specific group of feed stream constituents. The arrangement and design of these hardware sections is based upon generating maximum quantities of quality synthesis gas at minimum operational cost. Depending upon the combination of material to be gasified, the best section of the gasifier is selected for material feed in accordance with maintaining the balanced combination of hydrocarbons, carbonaceous materials and reaction gases. This allows control of the overall process as an exothermic reaction, resulting in maximum generation of synthesis gas for minimum expenditure of energy.

The following description of the preferred embodiments is merely exemplary in nature and is not intended to limit the invention, its application or uses.

In FIGS. 1 and 2 there is shown a front elevation of a gasifier 10, which consists of a refractory lined lid 11, an expanded diameter, increased height reaction vessel 12, an induction furnace 13 mounted below and integral with the reaction vessel 12 and a tilt frame 14. Tilt frame 14 consists of a base plate 15, two vertical columns 16, gussets 17 and two hydraulic cylinders 18 to tilt gasifier 10 for maintenance.

As illustrated in FIG. 3, refractory lined lid 11 is fitted with an exhaust plenum 21 to remove the synthesis gas 22, one or more top lances 23 to introduce oxygen, carbon dioxide, steam, other gases or liquids 24 and solid material feed 25 into the gasifier, one or more devices to measure the temperature 26 in the gasifier, one or more devices to measure the gas composition 27 and a burner port 28 to house a burner for preheating the gasifier. Exhaust plenum 21 includes a refractory lining 29 for preventing heat loss therethrough.

Reaction vessel 12 is fitted with a refractory lining 31 to contain a molten metal 32, a slag 33, a froth 34 and a off-take region 47. Excess slag 33 is continuously removed from the vessel by means of a siphon slagger 35. The solid material feed 25 is introduced from above by means of one or more top lances 23 through lid 11 or through exhaust plenum 21 and lid 11. Solid, liquid or gaseous feed 36 is also introduced by means of one or more side wall injectors 37. Gaseous

and liquid feed can also be introduced into froth 34 or off-take region 47 utilizing injector ports located along the side walls of top injection lances 23. On the side walls of top lances 23, one or more side wall ports 48 located in froth 34 and one or more side wall ports 49 located in off-take region 47 can be effectively utilized due to the expanded diameter and increased height (freeboard) of reaction vessel 12. The bottom of reaction vessel 12 is fitted with a water cooled flange 38 to which furnace 13 is attached. One or more bottom injector lances 50 can also be utilized to enhance the mixing action and gasification process from below, again due to the expanded diameter of reaction vessel 12. Solids, liquids or gases may also be introduced through bottom injector lances 50.

Preferably, furnace 13 is a coreless induction furnace. The heart of a coreless induction furnace is the coil, which consists of a hollow section of heavy duty, high conductivity copper tubing which is wound into a helical coil. Coil shape is contained within a steel shell and magnetic shielding is used to prevent heating of the supporting shell. To protect it from overheating, the coil is water-cooled, the water being re-circulated and cooled in a cooling tower or chiller.

A channel induction furnace can also be used. Channel furnaces however consist of a refractory lined steel shell which contains the molten metal. Attached to the steel shell and connected by a throat is an induction unit which forms the melting component of the furnace. The induction unit consists of an iron core in the form of a ring around which a primary induction coil is wound. This assembly forms a simple transformer in which the molten metal loops comprise the secondary component. The heat generated within the loop causes the metal to circulate into the main well of the furnace. The circulation of the molten metal effects a useful stirring action in the melt. Channel furnaces however suffer the drawback of requiring an initial molten metal charge from another source for cold start. In addition, for normal operation, the feed rate of the carbonaceous material and reaction gases is balanced so that the molten iron retains its high carbon content. This allows operation in the optimum portion of the Fe-C Equilibrium Chart. If this balance should be temporarily lost, and the carbon is depleted from the molten iron, then steel will be made in the bath. This would require a notable increase in

temperature to maintain the molten state of the metal while high purity carbon is injected back into the bath to restore the iron. This additional heat requirement would severely strain most channel furnaces. In many cases the channel furnace would have to be shutdown and recharged from a cold start. There is no such
5 problem with a coreless induction furnace which could maintain the required higher temperatures. This ability to sustain continuous operation in the presence of highly varying reactions and feed streams is critical to the overall efficiency and economics of the process. Finally, channel furnaces require additional molten iron
10 depth in order to avoid oxide build up or clogging in the refractory channels. This additional iron is not conducive to the basic gasification reaction efficiency. Therefore, coreless induction furnaces provide a preferred flexibility and adaptability not found in channel furnaces.

A second embodiment of this design is shown in FIGS. 5 and 6. This configuration utilizes three induction furnaces 13 on a larger reaction vessel 12 to facilitate a larger
15 molten bath to enable higher capacity material throughputs. Variations in this approach can accommodate 2 or up to 6 induction furnaces 13 for a single reaction vessel 12. The use of multiple induction furnaces 13 for larger reaction vessels 12 allows uniform stirring action and heat distribution, thus enhancing the synthesis gas reaction and avoiding cold spots in the larger molten metal volume. Further, since induction furnaces are single phase devices,
20 each inductor can be connected to one of the three phases of a standard three phase industrial power supply. Thus, use of a phase balancer can be eliminated. As a result, this approach also saves equipment costs while increasing electrical efficiency. In addition, this larger reaction vessel 12 does not utilize a tilt frame for emptying and maintenance, but rather uses a series of tap holes to save on cost and complexity of design. Excess slag
25 during operation is still removed by a siphon slagger.

The purpose of induction furnace 13 is to initially melt the solid pig iron and to subsequently stir molten metal 32 during operation. Induction furnace 13 is fitted with a refractory lining 42 which contains molten
30 metal 32. Surrounding refractory lining 42 is a coil 43 which is supported by magnetic shunts 44 which are supported by shunt bolts 45 which fasten to a furnace cage 46.

The manner in which gasifier 10 is started is as follows. Once gasifier 10 has been charged with solid pig iron, reaction vessel 12 is preheated to about 2200°F by means of a gas burner inserted through burner port 28 or alternately through a top mounted port for a lance 23. Electrical power is then applied to induction furnace 13 which melts and superheats molten metal 32 to about 2700°F. The frequencies used for induction melting vary from 50 cycles per second to 10,000 cycles per second. The higher the operating frequency, the greater the maximum amount of power that can be applied to induction furnace 13 and the lower the amount of turbulence induced.

When the charge material is molten, the interaction of the magnetic field and the electrical currents flowing in induction coil 43 produce a stirring action within molten metal 32. This stirring action forces molten metal 32 to rise upwards into reaction vessel 12. The degree of stirring action is influenced by the power and frequency applied as well as the size and shape of coil 43 and the density and viscosity of molten metal 32. The stirring action within the molten metal bath is important as it helps with mixing of molten metal 32 as well as homogenizing of temperature throughout induction furnace 13 and reaction vessel 12.

FIG. 4 illustrates a cross section of a gasifier 10 showing the chemical reactions that take place therein. Oxygen is introduced into molten metal 32 by means of one or more oxygen lances 23. As the oxygen impinges on molten metal 32, which initially consisted of iron, carbon and silicon, the oxygen initially oxidizes the iron to iron oxide as follows:



The silicon dissolved in molten metal 32 is then oxidized to silicon dioxide as follows:

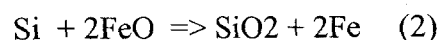

Likewise, the carbon dissolved in molten metal 32 is then oxidized to carbon monoxide as follows:

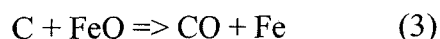

The oxidation of the iron to iron oxide and silicon to silicon dioxide involves minimal volumetric change. However, as the carbon is oxidized to carbon

monoxide, there is a significant increase in volume when a solid is oxidized to a gas. This volumetric expansion causes molten metal 32, the liquid iron oxide, the liquid silicon dioxide and slag 33 to form froth 34.

If the carbon is not replenished, the oxygen will remove virtually all of the carbon in molten metal 32 in about fifteen minutes. Thereafter, froth 34 will collapse and the iron will be completely oxidized to iron oxide. To maintain froth 34 and molten metal 32, the carbon must be injected at a rate equal to the rate at which the carbon is being removed by oxidation, as follows:

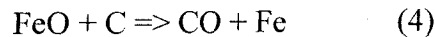

This insures that the iron that was oxidized to iron oxide is then subsequently reduced by the carbon returning most of the iron to molten metal 32 so that it can subsequently be re-oxidized thereby allowing the cycle to repeat indefinitely. This continuous recycling is important to the efficiency of the process. Since some of the iron oxide will be carried out of reactor vessel 12 as part of slag 33, there will be a depletion of molten metal 32. Consequently, the iron will have to be added to reactor vessel 12 to maintain the required level of molten metal 32 in the gasifier.

As solid feed 25 is injected into molten metal 32, some of it will dissociate into the carbon and hydrogen and some will remain as a hydrocarbon. Likewise, as liquid or gaseous feed 36 is injected into froth 34, slag 33 or molten metal 32, some of it will dissociate into carbon and hydrogen and some will remain as a hydrocarbon. That portion of feeds 25 and 36 that dissociates will cause molten metal 32 to froth as the hydrogen is released as a gas. To dissociate feeds 25 and 36, heat must be provided, as follows:

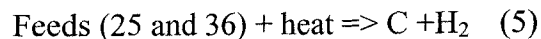

Likewise, that portion of feeds 25 and 36 that is oxidized to carbon monoxide, carbon dioxide and water vapor by the oxygen will cause molten metal 32 to froth.

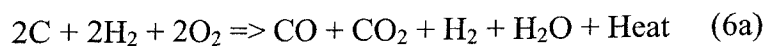

The frothing process is most important since it increases the surface area for the following reaction.



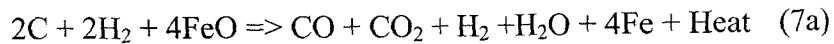

The amount of oxygen added is closely controlled so that the heat released will provide the heat to dissociate feeds 25 and 36 and provide the heat required to elevate the synthesis gas to a temperature high enough to keep froth 34, slag 33 and metal 32 molten. The operating temperature will be in the range of 2700-3000°F.

The resulting synthesis gas consists of carbon monoxide, carbon dioxide, hydrogen and water vapor. The ratio of the products in the synthesis gas is controlled by the following equilibrium:

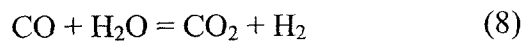

The equilibrium constant for equation 7 is equal to:

$$k = [pCO_2 \times pH_2] \div [pCO \times pH_2O] = [6355 \div (-R \times T)] - [6.24 \div (-R \times T)] \quad (9)$$

Where p = Pressure

R = Gas Constant

T = Temperature

Since the equilibrium constant k is temperature dependent, the percentage of each gas will vary with temperature. The higher the temperature the greater the amounts of carbon monoxide and water vapor. Conversely, the lower the temperature, the greater the amounts of carbon dioxide and hydrogen. The ratio of carbon compounds formed to the hydrogen compounds formed is directly proportional to the amount of carbon and hydrogen in feeds 25 and 36.

Reaction vessel 12 is maintained under either a slightly negative, neutral or slightly positive pressure to remove the hot synthesis gas via exhaust plenum 21 while maintaining the proper reaction and diffusion of gases from molten metal 32 and slag 33. Exhaust plenum 21 is refractory lined 29 since the synthesis gas exits at temperatures as high as 2700 to 3000°F.

Because feeds 25 and 36 contain some metallic elements, they oxidize and become part of slag 33 or molten metal 32. When these metal oxides cause slag 33 to go basic, silica sand can be added to keep slag 33 fluid. Conversely, when these metal oxides cause slag 33 to go acidic, dolomitic limestone can be added to lower the melting point of slag 33 to keep it fluid. It should be noted that slag chemistry in

5 this process is important as it relates to the viscosity of slag 33 and the necessity of controlling the continuity of the synthesis gas production. In addition, just as in a metal refining process, the chemistry of slag 33 is related to the removal of detrimental impurities. In the synthesis gas production, it is advantageous to keep
10 any impurities, such as sulfur and phosphorous, in metal bath 32 or capture these impurities in slag layer 33 rather than having to remove them from the gas stream in some later step. The slag chemistry is monitored by periodic sampling and computer control. Siphon type slagger 35 is employed to continuously remove excess slag 33. Most heavy metals, if present in the feed stream, can also be
10 captured by the molten metal or slag regimes.

The following paragraphs now explain important features of each major hardware section.

Induction Furnace

15 Induction furnace 13 is integral with but separated from the elevated and expanded diameter reaction vessel 12 and provides the following key features:

- 20 i) Precisely controlled vertical stirring of the entire molten bed with minimal power consumption. This facilitates circulation of all molten metal 32 with no dead or cold spots thus enabling maximum utilization of all the iron in the gasification process.
- ii) Power variability in real time to accommodate changes in feed stream heat value and thermal conversion process interaction.
- iii) Control of vertical stirring turbulence and speed during the volatile thermal conversion reactions.
- iv) Induction coil 43 protection from volatile reaction vessel 12 molten
25 metal stirring and gasification process by isolation of induction furnace 13 below the primary thermodynamic reactions.
- v) Adaptable to real time re-charging of the molten metal if the carbon content drops too low.
- vi) Continuous operation with varying feed stream conditions and
30 gasification conditions.

Vertical stirring at minimum power is accomplished by the natural movement of metal bath 32 caused by induction coil 43. Control of power variability is achieved by means of a tapped transformer to vary the voltage to coil 43. By mounting elevated, extended diameter reaction vessel 12 on top of induction furnace 13, induction coil 43 and refractory lining 42 are isolated and thus protected from the volatile reactions of the gasification process. The superstructure of induction furnace 13 is specifically configured to support the weight of molten metal 32 and slag 33 in reaction vessel 12.

Elevated and Extended Diameter Reaction Vessel

Reactor vessel 12, or reaction chamber, is an elevated and extended diameter molten metal reaction section capable of sustaining efficient and stable FeO reaction during the injection of widely varying hydro-carbon material feeds. The extended bed diameter provides enlarged molten metal surface area and thus greater reaction zone potential. With greater surface area, it is also possible to inject multiple feed stream types and multiple process reactants requiring separate injector lance systems 23. This greatly enhances the flexibility of the system to tolerate the widely varying feed stream characteristics.

The bottom portion of elevated and extended diameter reaction vessel 12 is a designed curved member. This curved member is capable of supporting the weight of molten metal 32, slag 33, refractory lining 31, the vertical portion of reaction vessel 12, lid 11, exhaust plenum 21 and injection lances 23 while providing superior molten metal flow characteristics. Larger diameter reaction vessels requiring multiple induction furnaces, as shown in FIGS. 5 and 6, can be equipped with square, reinforced bottom sections to allow more uniform metal depth distribution and reduced equipment cost.

Reaction vessel 12 can be increased in vertical capacity by adding sections between the reaction vessel 12 and lid 11 interface. This allows an easy, cost-effective increase of iron capacity and froth region 34 volume for changes in feed stream composition and quantity. This design flexibility, coupled with the broad surface area permits extensive control and use of the iron-carbon and oxygen reaction to maintain the exothermic reaction and carbon exchange without depleting

the net carbon content of molten metal 32. Top lance 23 and side injection lances 37 are provided in the integrated design to accomplish this flexibility of operation by simple modifications to reaction vessel 12 design.

Refractory and insulation material for lining 31 of reaction vessel 12 is specifically selected to accommodate the volatile FeO reaction, Fe-Carbon exchange and the incumbent splashing and spalling which occurs. This material is also used to assure minimal heat loss. This refractory incorporates basic materials such as magnesia carbon brick in areas in contact with the metal bath and in proximity of the slag line. Above the slag line, where the refractory may be subject to acid, neutral, or even slightly basic conditions, a neutral refractory such as alumina or chromia-alumina spinel would be more appropriate. In off-take region 47 and duct areas, where temperatures will be more moderate, emphasis is placed on abrasion resistance to counteract the effect of any carry-over particulate combined with high gas stream velocity. The sidewall is brick while the bottom refractory is a monolithic. The refractory is installed by means of a staggered joint configuration. The expanded diameter of the reaction vessel 12 allows:

- i) Variable feed stream injection from multiple top injector lances 23.
- ii) Multiple (typically 3-6) side lance 37 injection ports to facilitate liquid solid and gaseous feed injection in a variety of configurations.
- iii) Multiple side lance 37 injection ports to facilitate stirring action in the horizontal plane of the molten bed, thus enhancing total reaction mixing.
- iv) Varying injection speeds due to multiple locations to enhance and control the size and depth of the molten metal reaction zone.
- v) Isolation of the total reaction zone in a controllable region.
- vi) Increased capability to operate in the required region of the Fe-C equilibrium chart for widely varying feed.

Slag Region

The silica slag region is purposely provided in special combinations which:

- i) Captures and further gasifies carbon particulates escaping the FeO
- Iron- Carbon reaction.
- ii) Captures and neutralizes certain waste gases not productive in the
synthesis gas generation process.
- 5 iii) Captures and neutralizes other non-carbon particulates.
- iv) Enhances the formation of the appropriate secondary froth reaction
zone constituents to support a second synthesis gas production area.
- v) Coats the surrounding refractory with a protective layer as a result of
splashing from the volatile gasification reaction.
- 10 vi) Provides refractory design transition from molten metal to freeboard
areas of gasifying reaction vessel.

Secondary Reaction Froth Region

This section provides a volume large enough to allow control of secondary
gasification reaction. Directly above molten metal 32 and slag 33 regions, froth
15 region 34 is typically three to fifteen times the depth of the molten metal section,
depending upon the type of mixed feed stream material involved. As previously
discussed, during the injection of hydrocarbon material and oxygen into molten
metal 32, it is common to experience a frothing or fine material expansion above
molten metal 32 and slag section 33. The purpose of froth region 34 is to provide
20 sufficient surface area and height, with the incumbent expanded injection location
capability, to create a controlled secondary gas reaction area which provides the
following features:

- i) Allows complete gasification of any hydrocarbon particulates not
fully reacted in the molten metal 32 gasification section.
- 25 ii) Facilitates the introduction of additional hydrocarbon fines and
reaction gases to allow additional gasification reaction and boost
synthesis gas production. These fines can include coal, spent tires,
waxes, waste oils, industrial waste chemicals, and bio-solids.
- 30 iii) Provides a large transition area for changes in refractory design and
thickness.

- iv) Allows for an extended siliceous slag 33 area and “controlled extended” splash zone thus enhancing refractory coating and synthesis gas production in a continuous process.
- v) Allows for thicker slag area to accommodate additional slag chemicals for improved synthesis gas filtration and increased residence time.
- vi) Permits secondary injection of by-products and waste gases (see Table 1) to accelerate and expand synthesis gas formation.
- vii) Permits secondary injection of gaseous reactants such as oxygen, CO₂ or water vapor to control and enhance temperature levels and H₂ and CO formation.

Expandable Off-Take Zone

Off-take zone 47 is specifically provided to allow control of the height and intensity of froth region 34 and provide a stable transition of the expanding synthesis gas into lid 11 and exhaust plenum 21. For some feed stream conditions, the height and extent of froth region 34 can grow too rapidly and interfere with the controlled synthesis gas production and transition into lid 11 and plenum 21 sections. Therefore off-take zone 47 is provided to allow injection of pure light gases, oxygen, carbon dioxide, or water vapor to create a hot spot (or cold spot) which will place a controlled cap or limiter to the upper extent of froth region 34. Care must be taken not to inject too much oxygen or carbon/hydrocarbon material into off-take zone 47, resulting in excessive depletion of froth zone 34. As a result, injection into off-take zone 47 is often an intermittent process, occurring only long enough to keep froth 34 out of exhaust plenum 21. This “capping” or stopping of froth region 34 vertical expansion is important to the overall efficiency and control of the gasification process. This area is topped by a flanged connection to lid 11 which allows design expansion of froth region 34 and off-take region 47 due to changes in the feed stream characteristics or quantity, as well as changes in the thermal conversion process. This is accomplished simply by the addition of one or more refractory lined circular sections between off-take region 47 and lid 11. Off-take region 47 also provides an additional “pure injection” zone for certain gaseous

materials available from waste by-products, landfills, Fischer Tropsch by-products and digesters as outlined in Table 1.

Lid

Lid section 11 is designed to:

- 5 i) Retain the maximum amount of heat in reaction vessel 12.
- ii) Converge escaping hot synthesis gas flow efficiently to the exhaust plenum 21.
- iii) Provide first level instrumentation of quality and status of product gases.
- 10 iv) Resist erosion wear for particulates and high velocity gas flow.

Lid 11 has a designed curvature which maximizes the stability of high thermal insulating refractory installation while minimizing surface flow tension and erosion characteristics. The specially selected refractory material is designed to minimize heat loss for reduced thickness. This facilitates maximum inside diameter and minimum exterior (outside) hole-size for exhaust plenum 21.

Exhaust Plenum

Exhaust plenum 21 is designed to provide:

- 20 i) Maximum heat retention.
- ii) Minimum surface tension erosion characteristics.
- iii) Minimum outside diameter.
- iv) Efficient gas turning with minimum inside diameter (ID).
- v) Proper gas escape velocity.
- vi) Minimum collection of particulates and contaminants in the turn section and downstream areas.
- 25 vii) Proper reaction vessel pressure.

These features provide a combined aerodynamic, thermodynamic gas flow, characteristics needed to maximize gasification efficiency and control. Advanced state-of-the-art thermal insulating materials are used to extend life and maximize heat retention.

The preferred embodiments of the present invention can process and gasify a large array of mixed wastes and fuels from domestic and industrial applications. These wastes and fuels can be contaminated with a variety of in-organics and hazardous materials. Thus, the present invention allows for versatility and adaptability of design to accommodate a variation of organic and in-organic material and still achieve high efficiency in synthesis gas production. However, this same versatility and adaptability of design implementation can be very useful in other applications and embodiments.

Claims

Having set forth the nature of the present invention, what is claimed is:

1. A gasifier comprising,
an induction furnace defining a first volume,
a reaction chamber configured for containing a continuous gasification
5 reaction, the reaction chamber defining a second volume that is in direct fluid
communication with the first volume,
wherein the induction furnace includes induction coils that are essentially
isolated from the gasification reaction.
2. The gasifier according to claim 1 wherein the induction furnace is a coreless
10 induction furnace.
3. The gasifier according to claim 1 wherein the induction furnace is
configured for vertically stirring a molten metal located within the second volume.
4. The gasifier according to claim 1 further comprising a dome-shaped lid
configured direct the fuel gas and heat produced from the gasification reaction to an
15 exhaust plenum.
5. The gasifier according to claim 4 further comprising a plurality of lance
receiving slots through the lid and slots through a sidewall and a bottom of the
reaction chamber.
6. The gasifier according to claim 1 further comprising means for continuously
20 delivering a carbonaceous fuel and reaction gases to be gasified into the reaction
chamber in a manner that does not project the gasification reaction into the
induction furnace.
7. The gasifier according to claim 1 wherein the second volume has an inside
working circumference that is at least three times greater than an inside working
25 circumference of the first volume, wherein the second volume provides a froth
gasification reaction zone directly below and integral with an off-take zone, the
froth zone being directly above a molten metal area and a slag area.
8. The gasifier according to claim 1 further comprising two or more induction
furnaces operatively coupled to a bottom of the reaction chamber, each of the two

or more induction furnaces including an interior volume that is in direct fluid communication with the second volume.

9. A gasifier for the continuous production and collection of a fuel gas comprising,

- 5 a bottom mounted on top of an induction furnace,
an opening through the bottom directly coupling an interior of the induction furnace with an inside of the gasifier,
a continuous sidewall supported by the bottom, and
a top configured for removing the fuel gas from the gasifier.

10 10. The gasifier according to claim 9 wherein the induction furnace is a coreless induction furnace.

11. The gasifier according to claim 9 wherein the bottom has an inside working circumference that is at least three times greater than a circumference of the opening.

15 12. The gasifier according to claim 9 wherein the bottom is curved.

13. The reaction chamber according to claim 9 wherein the induction furnace includes coils that are isolated from a molten metal contained within the bottom.

14. The gasifier according to claim 9 wherein the induction furnace is configured for vertically stirring a molten metal contained within the bottom .

20 15. The gasifier according to claim 9 wherein the bottom and the interior of the induction furnace include a molten metal circulated therebetween by induction heating.

16. The gasifier according to claim 9 wherein the induction furnace is configured for maintaining a temperature of a molten metal contained within the
25 bottom within a predetermined range during continuous gasification of a widely varying carbonaceous feedstock.

17. A gasifier comprising,

- a reaction chamber,
a carbonaceous fuel delivery member for continuously delivering a
30 carbonaceous fuel into the reaction chamber, and

an induction furnace configured for continuous delivery of a molten metal into the reaction chamber.

18. The gasifier according to claim 17 wherein, when the induction furnace is a coreless induction furnace, the reaction chamber is integral with the induction furnace.

19. The gasifier according to claim 17 wherein the induction furnace is configured for continuous and controlled vertically stirring of the molten metal within the reaction chamber.

20. The gasifier according to claim 17 wherein the induction furnace is configured for maintaining a temperature of the molten metal within the reaction chamber within a desired range during the continuous gasification of the carbonaceous fuel.

21. The gasifier according to claim 17 wherein the induction furnace is coupled to a bottom of the reaction chamber and the bottom includes an opening through which the molten metal is delivered into the reaction chamber, the opening being at least three times smaller in circumference than the bottom.

22. The gasifier according to claim 17 wherein the reaction chamber includes an off-take zone configured for controlling a height of a froth contained within the reaction chamber.

23. The gasifier according to claim 17 wherein the reaction chamber has an inside working volume that is at least fifteen times greater than an inside working volume of the induction furnace.

24. The gasifier according to claim 17 wherein the reaction chamber includes a reaction area configured for receiving and gasifying the carbonaceous fuel, the reaction area being isolated from induction furnace and comprised of contiguous gasification zones, starting from a bottom of the reaction chamber and moving upward, designated as a molten metal zone, a slag zone, a froth zone and an off-take zone.

25. The gasifier according to claim 17 wherein the reaction chamber includes at least three coreless induction furnaces, equidistantly spaced and coupled to a bottom of the reaction chamber.

1/6

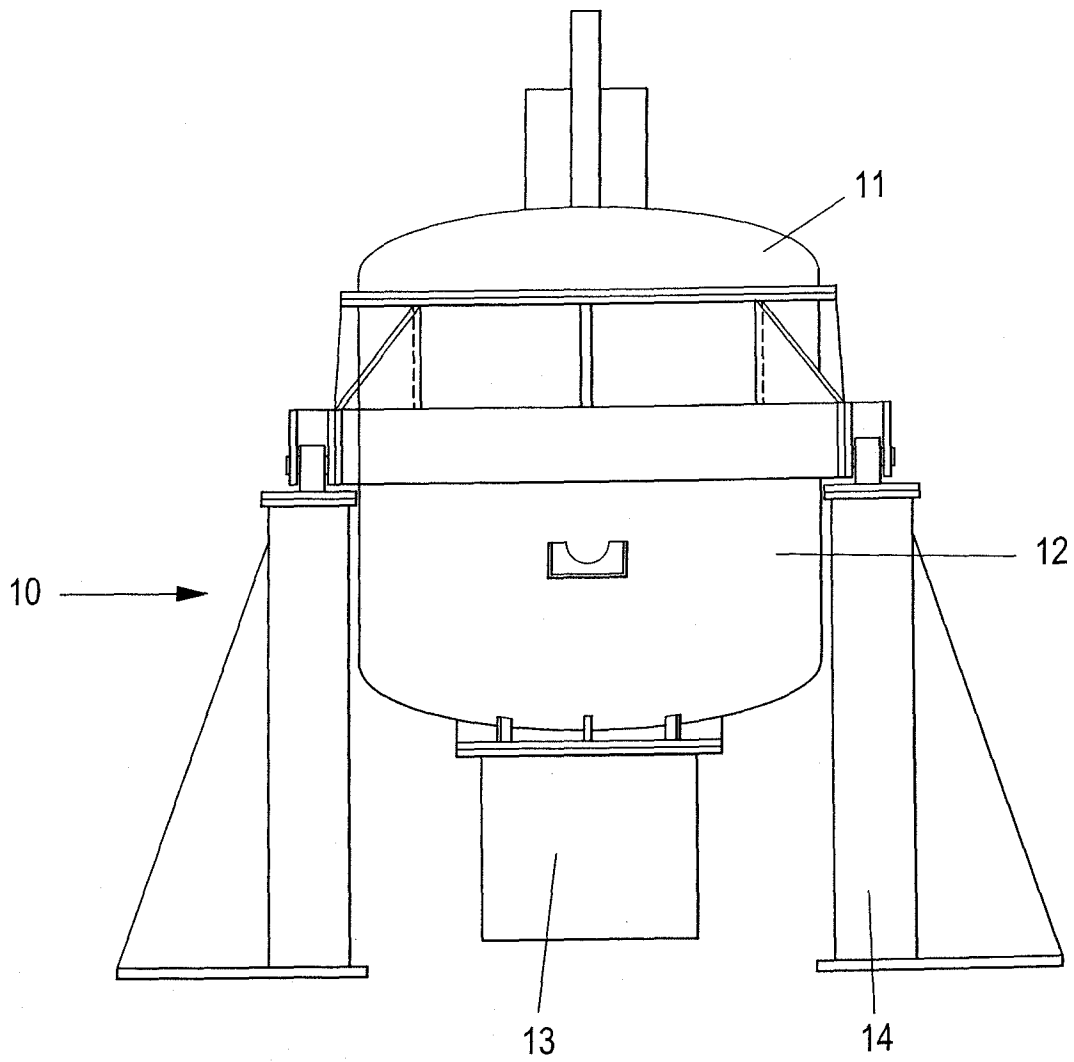

FIG. 1

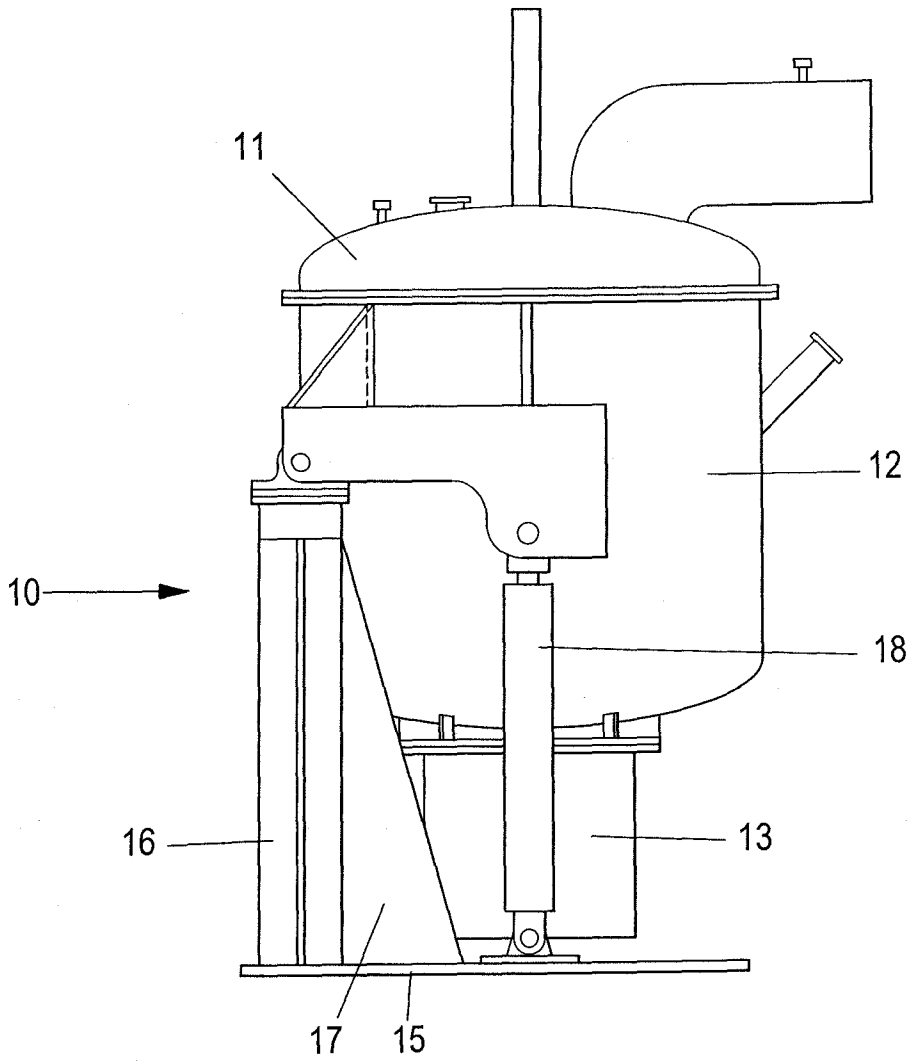

FIG. 2

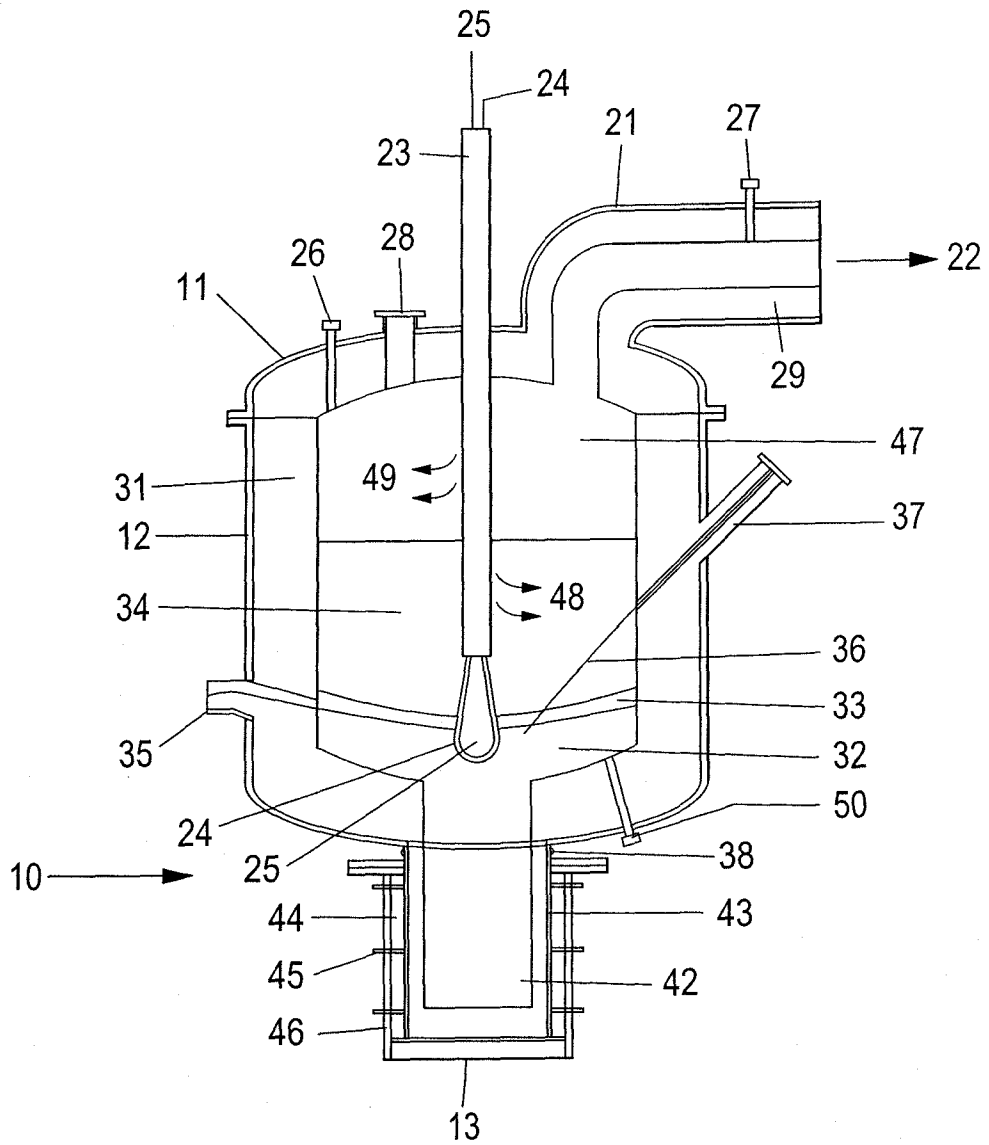

FIG. 3

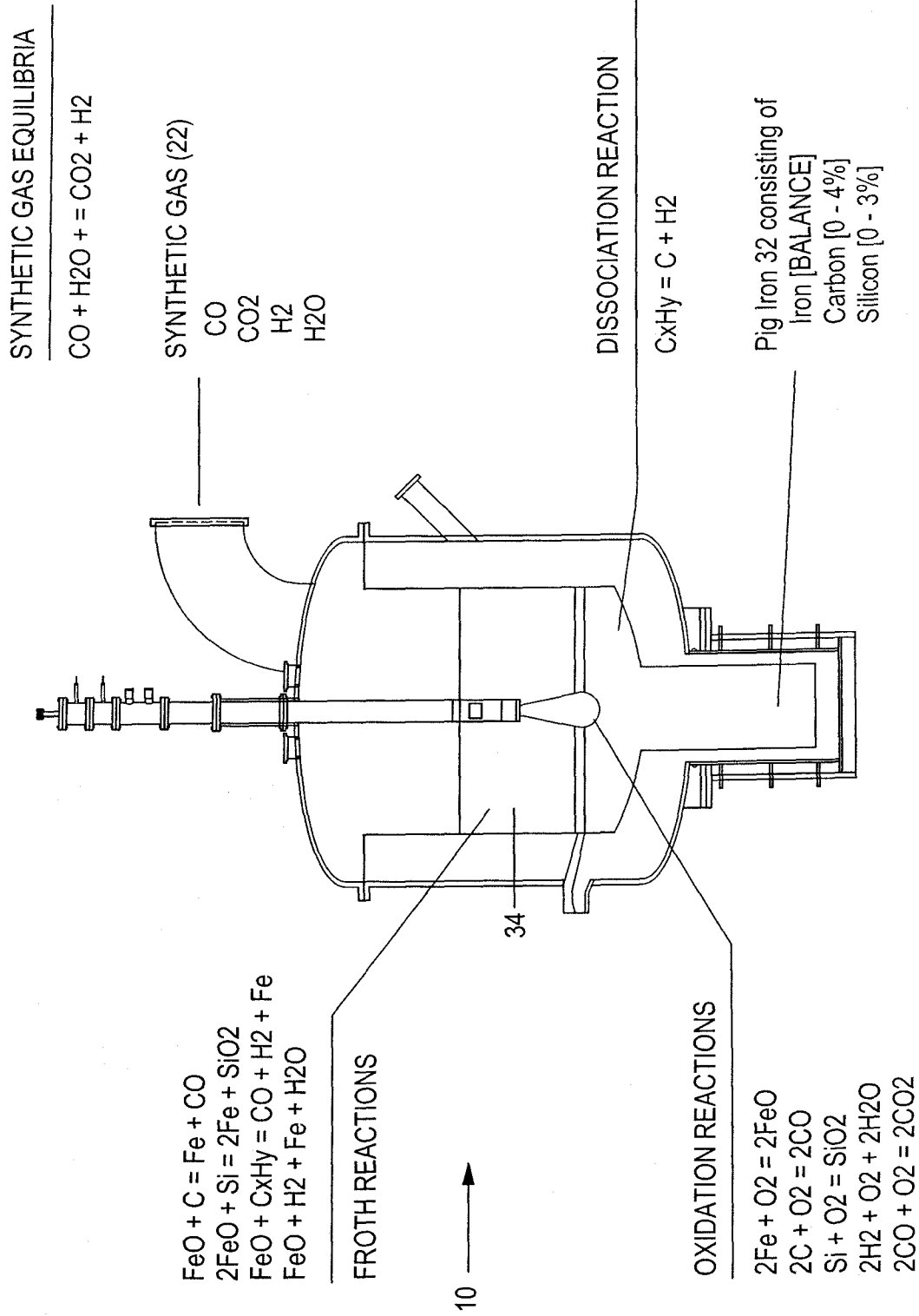

FIG. 4

5/6

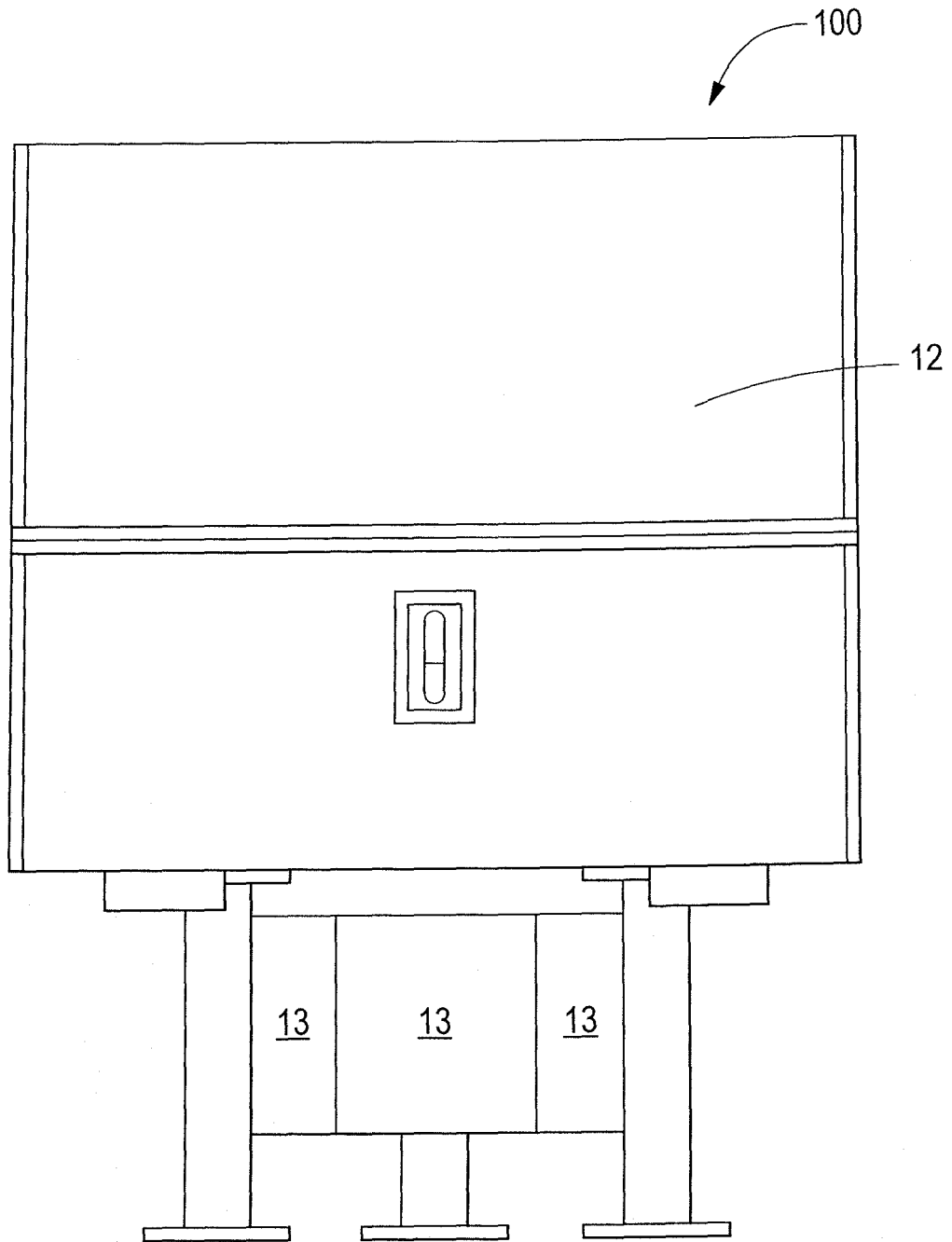

FIG. 5

6/6

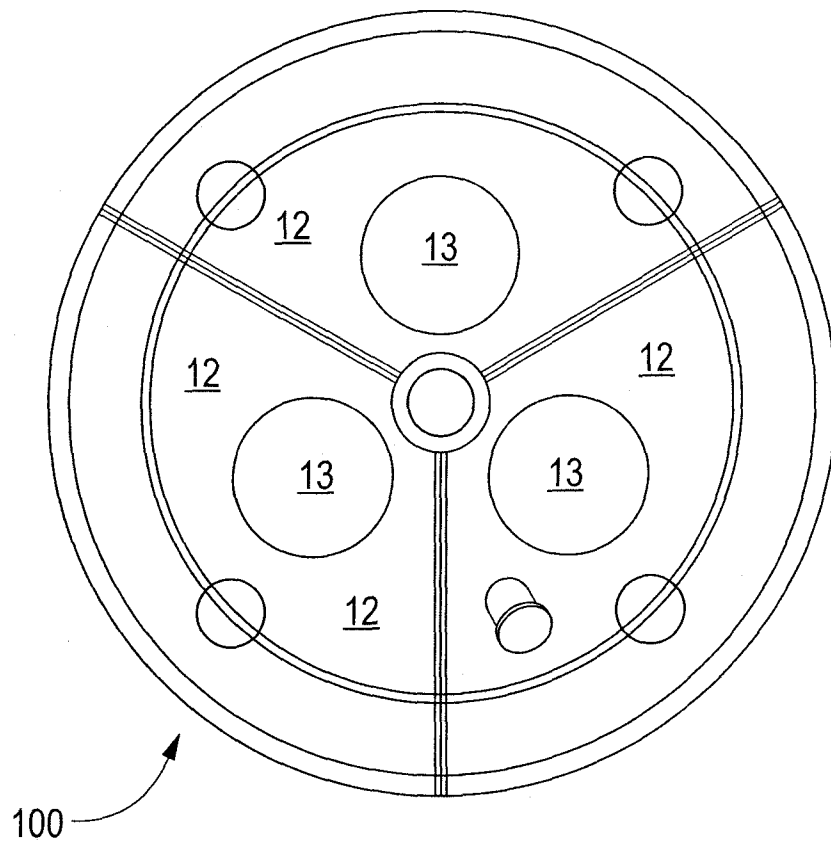

FIG. 6

A. CLASSIFICATION OF SUBJECT MATTER*C10J 3/48(2006.01)i, C10J 3/46(2006.01)i*

According to International Patent Classification (IPC) or to both national classification and IPC

B. FIELDS SEARCHED

Minimum documentation searched (classification system followed by classification symbols)

IPC 8 IPC 8 C10J 3/46, C10J 3/48, C10J 3/57

Documentation searched other than minimum documentation to the extent that such documents are included in the fields searched

Electronic data base consulted during the international search (name of data base and, where practicable, search terms used)

e-KIPASS (KIPO internal) and keywords: gasifier, carbonaceous fuel, chamber, molten metal, furnace, induction, and similar terms

C. DOCUMENTS CONSIDERED TO BE RELEVANT

Category*	Citation of document, with indication, where appropriate, of the relevant passages	Relevant to claim No.
A	GB 2189504 A (KLOECKNER-HUMBOLDT-DEUTZ AG.) 28 OCTOBER 1987 See abstract, figures 1-5, page 4, lines 14-82, and claim 1	1-25
A	US 4181504 (CAMACHO, S. L.) 1 JANUARY 1980 See abstract and figures 1-6	1-25
A	WO 94/04633 A1 (ASHLAND OIL, INC.) 3 MARCH 1994 See abstract and figures 1-10	1-25
A	EP 0154056 A1 (SUMITOMO METAL INDUSTRIES, LTD.) 11 SEPTEMBER 1985 See abstract, claim 1, and figures 1-3	1-25

 Further documents are listed in the continuation of Box C. See patent family annex.

* Special categories of cited documents:

"A" document defining the general state of the art which is not considered to be of particular relevance

"E" earlier application or patent but published on or after the international filing date

"L" document which may throw doubts on priority claim(s) or which is cited to establish the publication date of citation or other special reason (as specified)

"O" document referring to an oral disclosure, use, exhibition or other means

"P" document published prior to the international filing date but later than the priority date claimed

"T" later document published after the international filing date or priority date and not in conflict with the application but cited to understand the principle or theory underlying the invention

"X" document of particular relevance; the claimed invention cannot be considered novel or cannot be considered to involve an inventive step when the document is taken alone

"Y" document of particular relevance; the claimed invention cannot be considered to involve an inventive step when the document is combined with one or more other such documents, such combination being obvious to a person skilled in the art

"&" document member of the same patent family

Date of the actual completion of the international search

29 DECEMBER 2008 (29.12.2008)

Date of mailing of the international search report

30 DECEMBER 2008 (30.12.2008)

Name and mailing address of the ISA/KR

Korean Intellectual Property Office
Government Complex-Daejeon, 139 Seonsa-ro, Seo-gu,
Daejeon 302-701, Republic of Korea

Facsimile No. 82-42-472-7140

Authorized officer

PARK Jin

Telephone No. 82-42-481-8274



INTERNATIONAL SEARCH REPORT

Information on patent family members

International application No.

PCT/US2008/077617

Patent document cited in search report	Publication date	Patent family member(s)	Publication date
GB 2189504 A	28.10.1987	AU 7058287 A	29.10.1987
		BR 8701958 A	02.02.1988
		FR 2597881 A1	30.10.1987
		GB 8709810 D0	28.05.1987
		JP 62-265390 A	18.11.1987
		ZA 8702929 A	24.02.1988
US 4181504	01.01.1980	NONE	
WO 94-04633 A1	03.03.1994	AT 184633 T	15.10.1999
		CA 2140876 A1	03.03.1994
		DE 69326472 D1	21.10.1999
		DE 69326472 T2	18.05.2000
		DK 655084 T3	20.12.1999
		EP 0655084 B1	15.09.1999
		EP 0655084 A1	31.05.1995
		JP 2660102 B2	08.10.1997
		JP 7506145 T	06.07.1995
		KR 10-1995-0703042 A	23.08.1995
		US 5435814	25.07.1995
		US 5577346	26.11.1996
		US 5645615	08.07.1997
EP 0154056 A1	11.09.1985	NONE	