



US 20100186809A1

(19) **United States**

(12) **Patent Application Publication**
Samuelson et al.

(10) **Pub. No.: US 2010/0186809 A1**

(43) **Pub. Date: Jul. 29, 2010**

(54) **NANOWIRE- BASED SOLAR CELL STRUCTURE**

(30) **Foreign Application Priority Data**

Jun. 19, 2007 (SE) 0701513-4
Sep. 13, 2007 (SE) 0702072-0

(76) Inventors: **Lars Samuelson**, Malmo (SE);
Martin Magnusson, Malmo (SE);
Federico Capasso, Cambridge, MA (US)

Publication Classification

(51) **Int. Cl.**
H01L 31/00 (2006.01)
(52) **U.S. Cl.** **136/256**

Correspondence Address:
FOLEY AND LARDNER LLP
SUITE 500
3000 K STREET NW
WASHINGTON, DC 20007 (US)

(57) **ABSTRACT**

The solar cell structure according to the present invention comprises a nanowire (205) that constitutes the light absorbing part of the solar cell structure and a passivating shell (209) that encloses at least a portion of the nanowire (205). In a first aspect of the invention, the passivating shell (209) of comprises a light guiding shell (210), which preferably has a high- and indirect bandgap to provide light guiding properties. In a second aspect of the invention, the solar cell structure comprises a plurality of nanowires which are positioned with a maximum spacing between adjacent nanowires which is shorter than the wavelength of the light which the solar cell structure is intended to absorb in order to provide an effective medium for light absorption. Thanks to the invention it is possible to provide high efficiency solar cell structures.

(21) Appl. No.: **12/452,175**

(22) PCT Filed: **Jun. 19, 2008**

(86) PCT No.: **PCT/SE2008/050734**

§ 371 (c)(1),
(2), (4) Date: **Mar. 16, 2010**

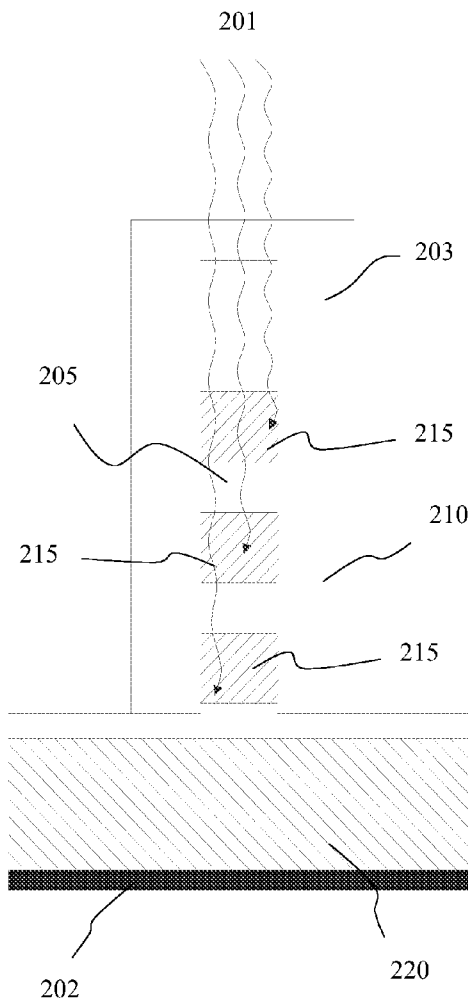

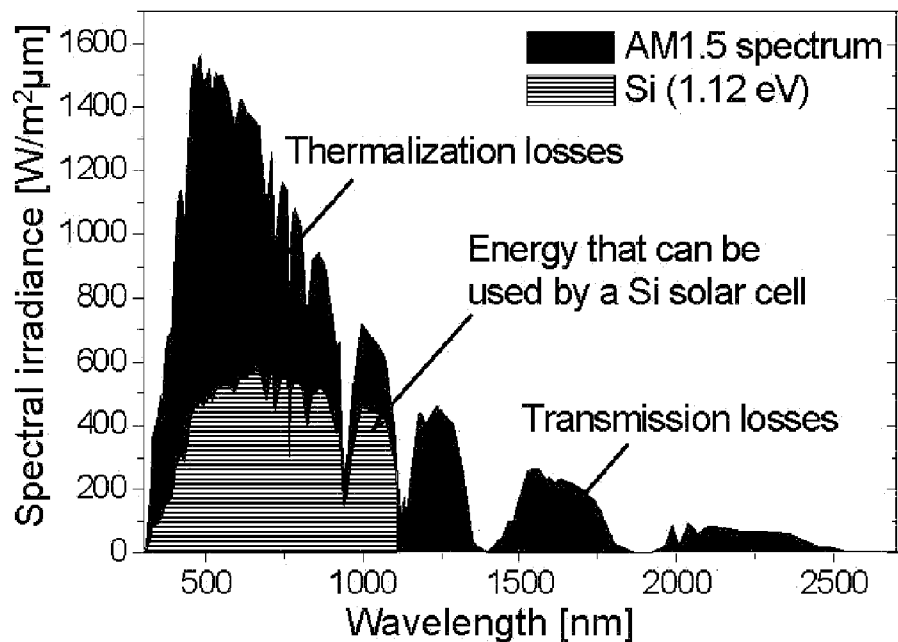

(a)

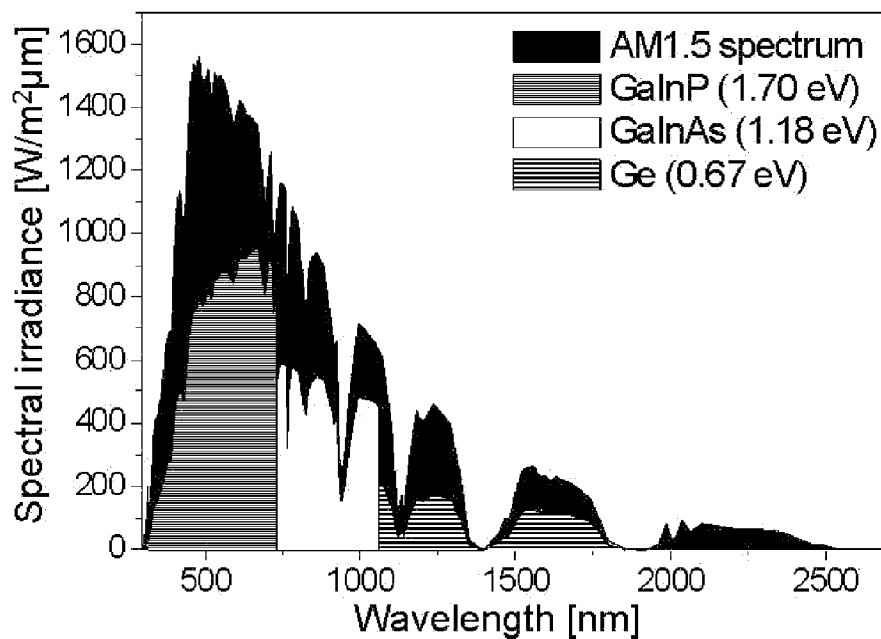

(b)

Fig. 1

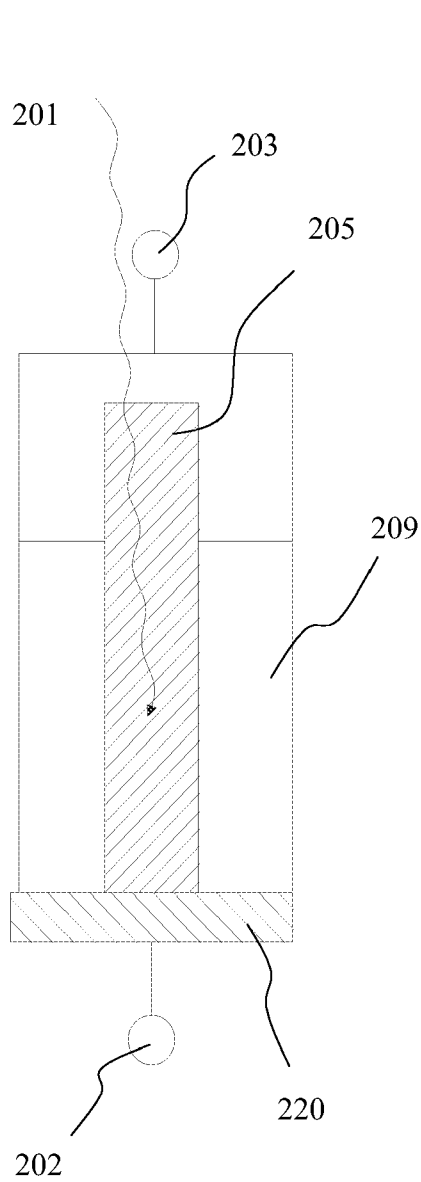

Fig. 2a

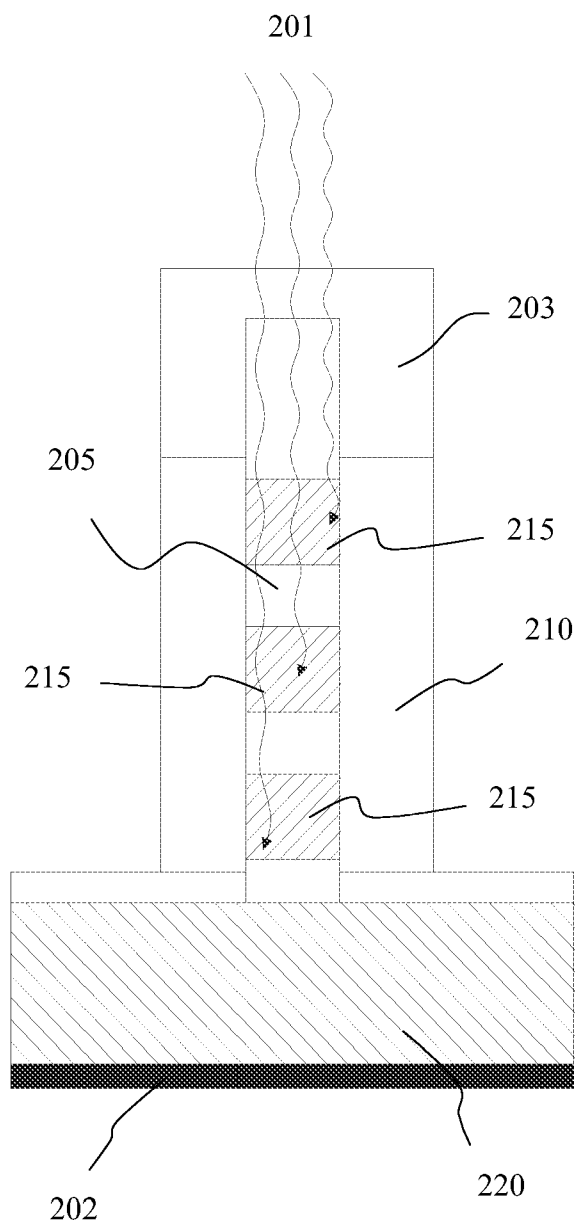

Fig. 2b

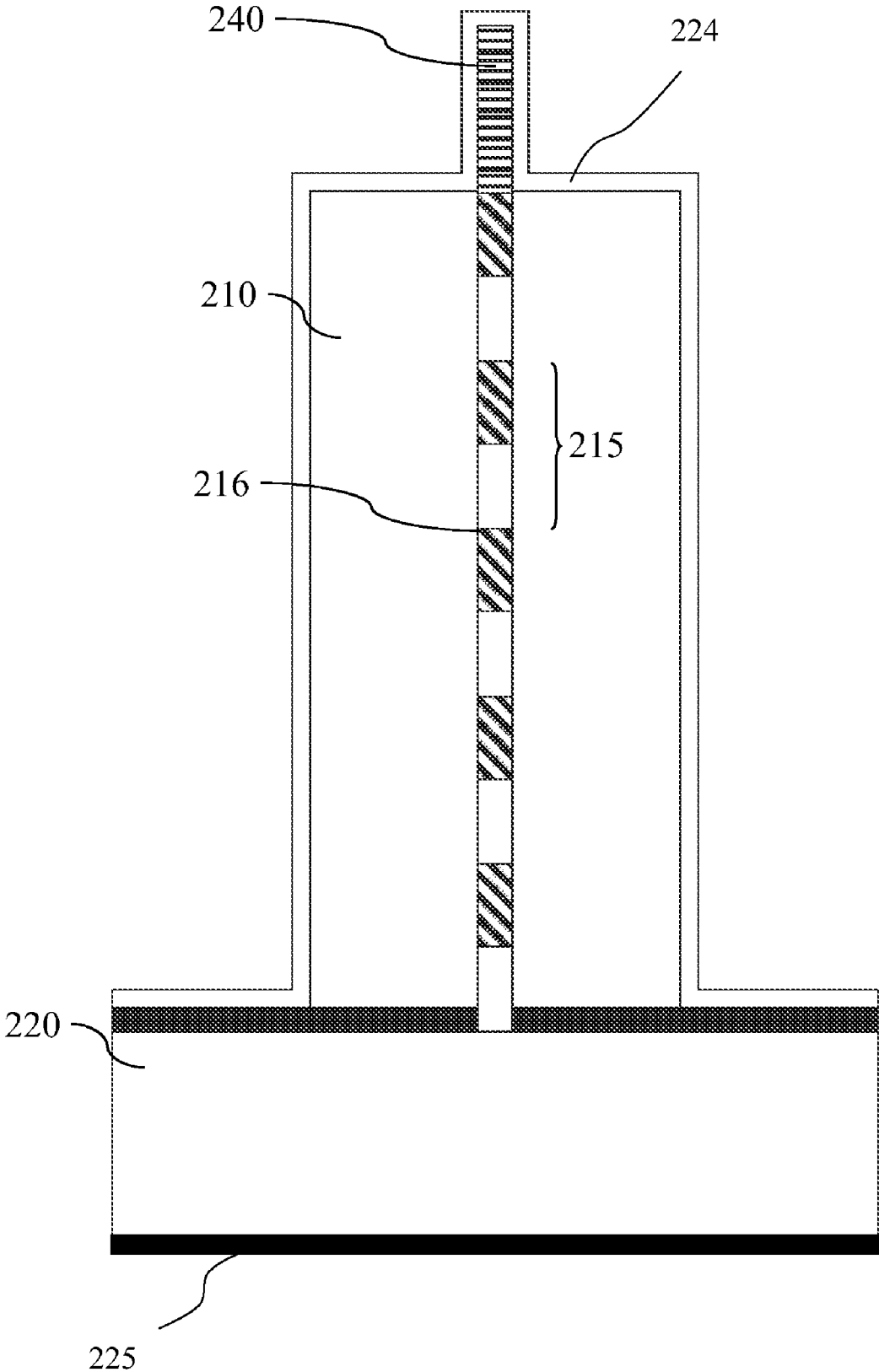

Fig. 3

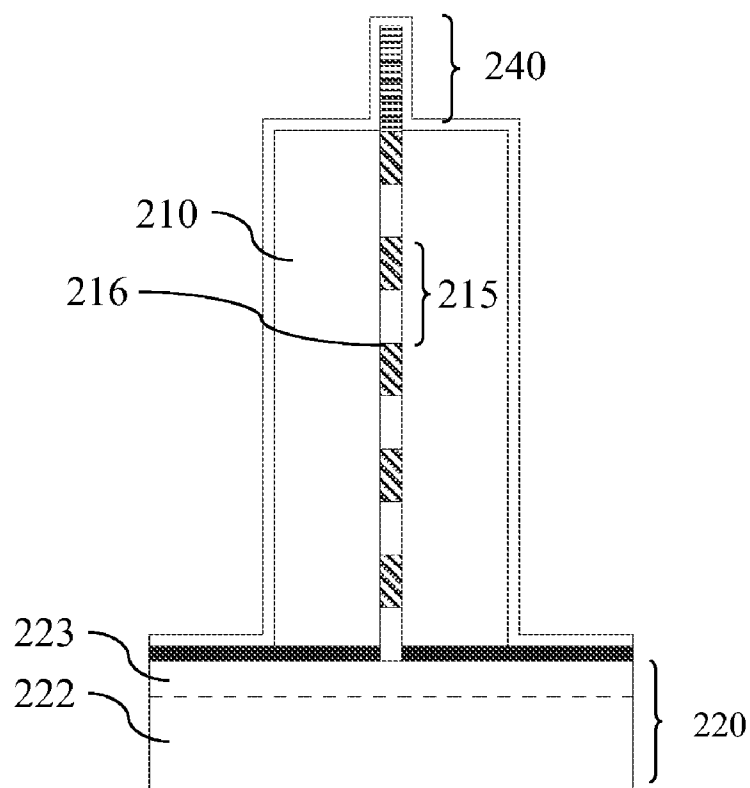

Fig. 4a

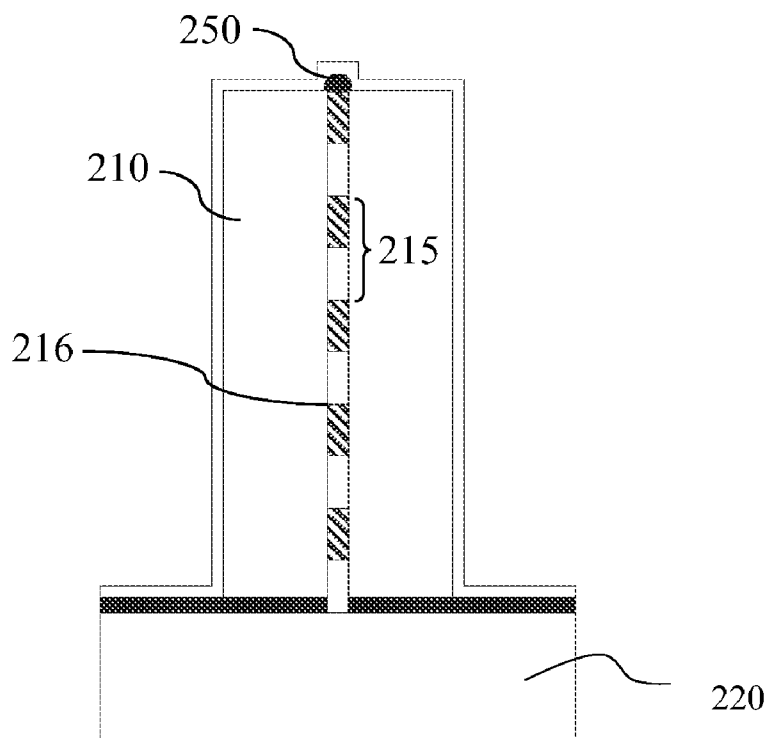

Fig. 4b

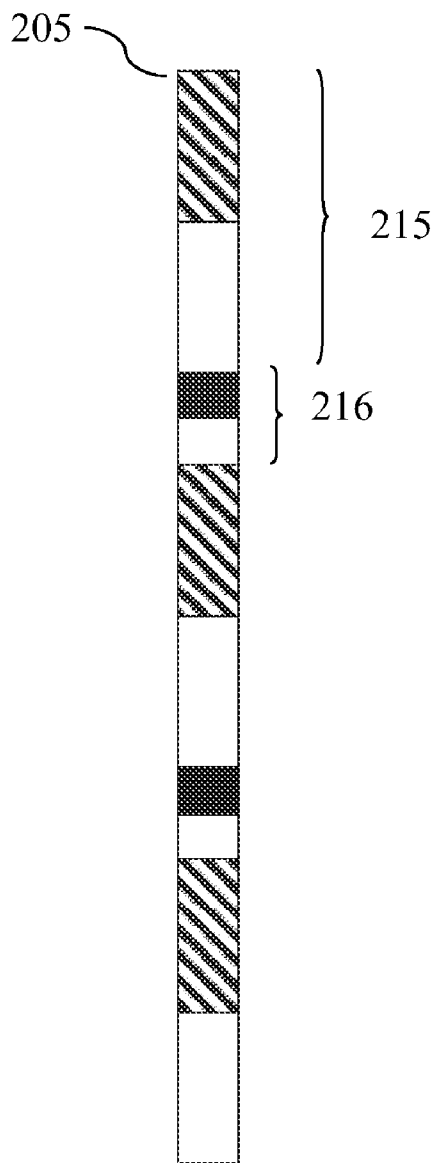

Fig. 5a

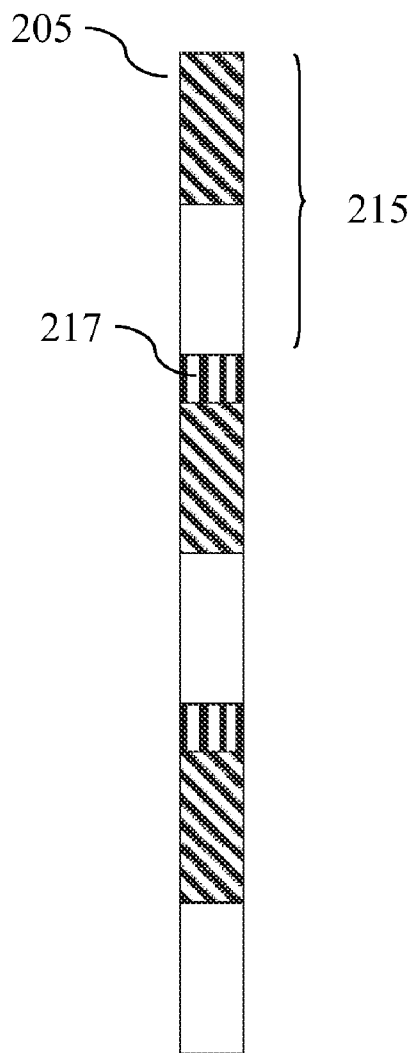

Fig. 5b

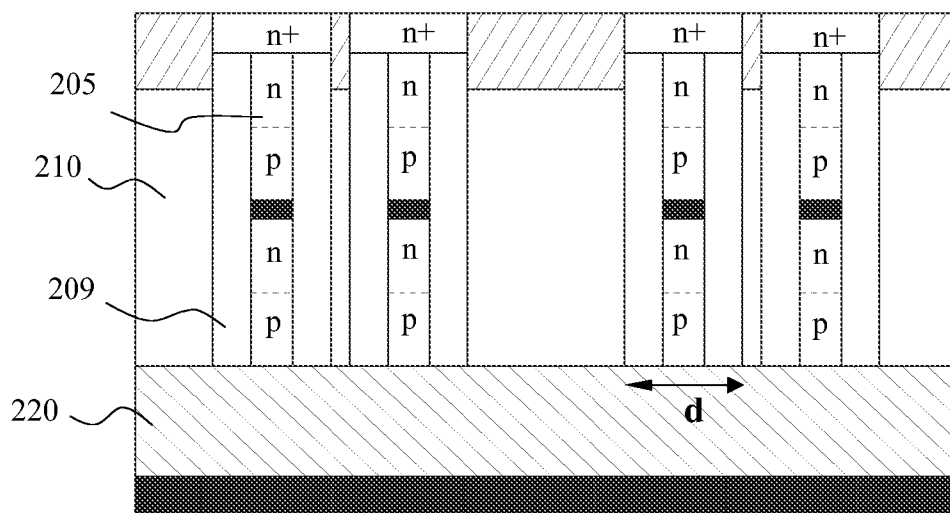

Fig. 6

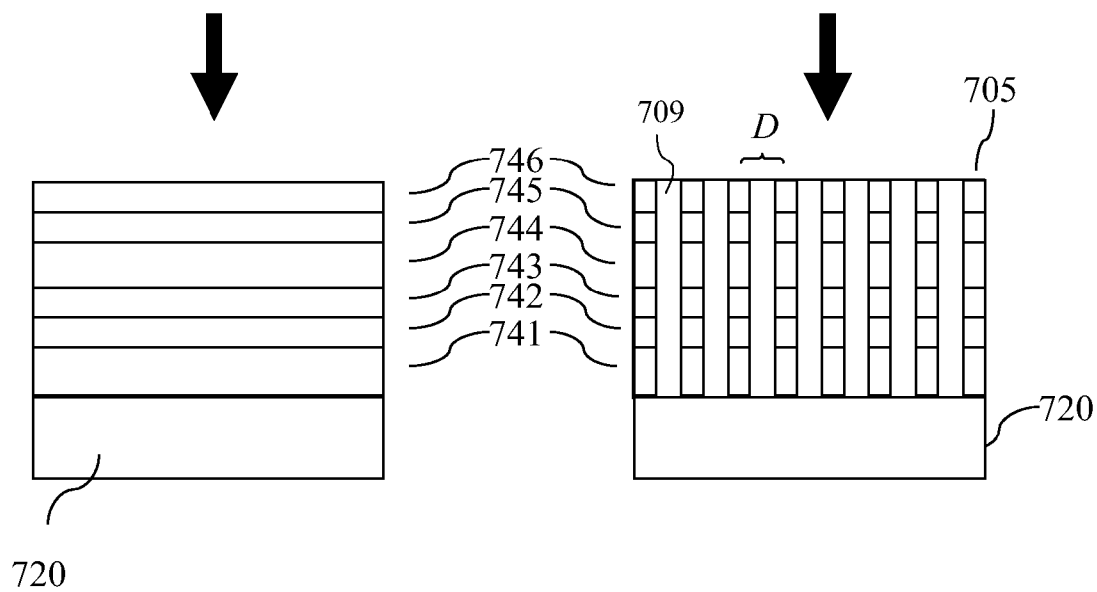

Fig. 7

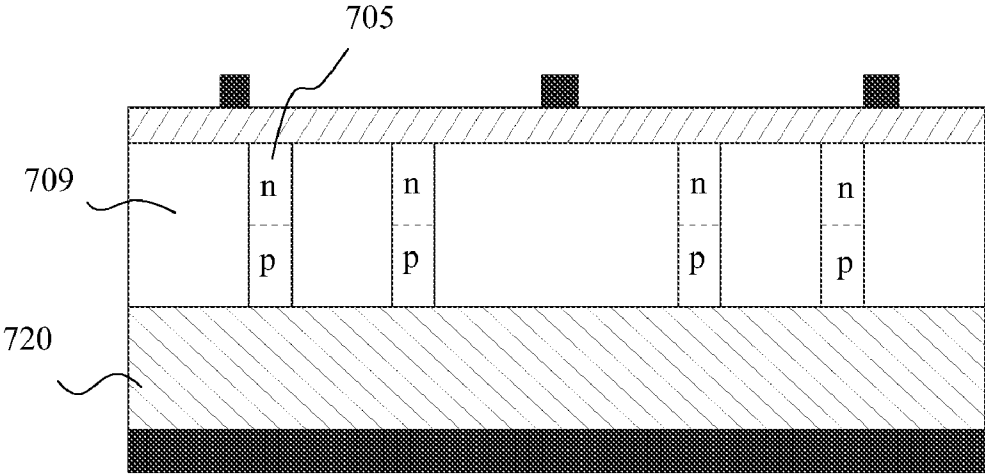

Fig. 8

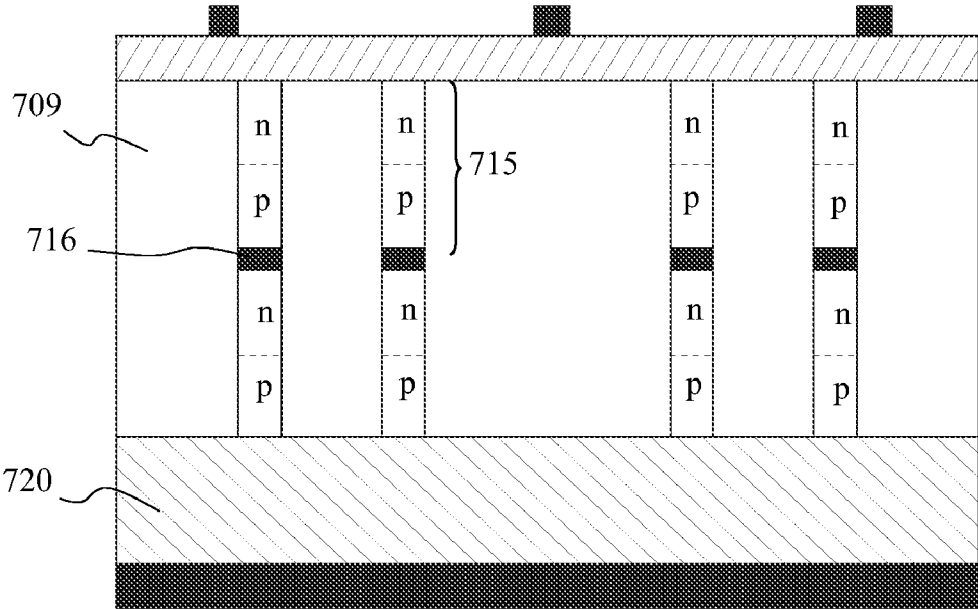
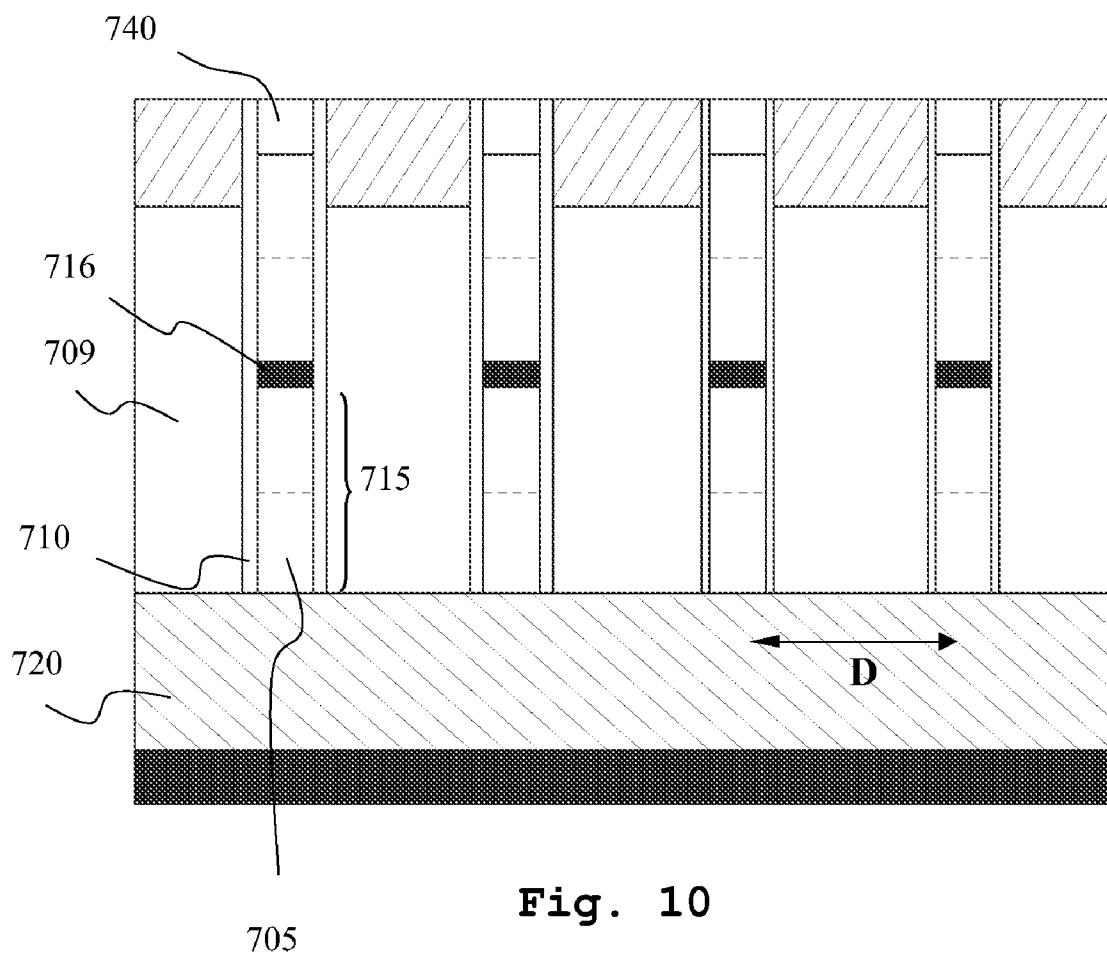

Fig. 9



NANOWIRE- BASED SOLAR CELL STRUCTURE

TECHNICAL FIELD OF THE INVENTION

[0001] The present invention relates to a solar cell structure. In particular the invention relates to a solar cell structure comprising a nanowire as an active component.

BACKGROUND OF THE INVENTION

[0002] Interest in solar cell technology has been increasing over the last years. Increasing energy costs as well as environmental concerns are factors behind this interest. Also technology breakthroughs, indicating the possibilities for large scale production of high efficiency solar cells have been important factors.

[0003] The most highly efficient existing solar cells are made of III-V semiconductors, such as GaInP or GaInAs, in multi junction cells with several layers each absorbing different parts of the solar spectrum. The advantage of this concept is illustrated by FIG. 1 showing the part of the solar AM1.5 spectrum that can be converted into electrical energy by a typical silicon photo voltaic (PV) cell compared to a GaInP/GaInAs/Ge tandem structure.

[0004] The theoretical limit for the power conversion efficiency of a solar cell based on a single semiconductor material is 31%. Multi junction photo voltaic cells (MJPV) can raise this limit to 43% for a dual junction and 49% for a triple junction solar cell. However, fabrication of all the necessary different material combinations is challenging and a high material quality of the crystals is essential for achieving high efficiencies.

[0005] Much progress has occurred and in December 2006 Boeing/Spectrolab announced (<http://www.spectrolab.com/com/news/news-detail.asp?id=172>) that they had demonstrated a record conversion efficiency of 40.7% using a 3-junction MJPV GaInP/GaInAs/Ge cells under 400x concentrated sunlight. This technology was, as mentioned in F. Dimroth, "High-efficiency solar cells from III-V compound semiconductors" *Phys. Stat. Sol. (c)* 3, 373 (2006), originally developed for space applications where Germanium (Ge) is a suitable substrate material. The availability of Ge in the Earth's crust is limited and it is expensive, and if such high efficiency tandem solar cells were used in large quantities on earth, this could be a limitation. For this reason, the development of multi junction solar cells based on crystalline Si, or even on simpler substrates, would open new opportunities for terrestrial applications, taking advantage of the higher multi junction efficiencies, lower cost and higher availability of Si substrates compared to Ge. A prior art multi junction photo-voltaic cell comprising lattice matched layers grown on a Ge substrate is disclosed in L. L. Kazmerski "Solar photovoltaics R&D at the tipping point: A 2005 technology overview" *J Electr Spectr Rel Phen* 150, 105 (2006)). This MJPV cell reaches efficiencies of more than 40% with concentrators.

[0006] However, technical barriers for planar III-V multi junction solar cells can be identified. Efficiencies above 50% will be very difficult to reach due to physical limitations. Conventional III-V materials for multi junction solar cells require perfect lattice matching over large substrate areas to avoid dislocations. Good device functionality will also require a very high degree of compositional homogeneity over an entire wafer. This makes up-scaling to large area substrates extremely challenging, even if such substrates

were available at reasonable cost. Even if these problems could be overcome, the limited number of materials that both have the right band gaps and are more or less lattice matched makes it very difficult to produce more than three junctions in planar solar cells, which is necessary for reaching very high efficiencies.

[0007] In addition to the above technical challenges, which are associated with the prior art multi junction cell, both cost and scaling present problems. By way of example multi-junction cells grown on Ge or III-V substrates are very expensive due to the high substrate costs and the small wafer sizes. Moreover, III-V materials are today epitaxially grown in high-grade MOCVD or even MBE reactors with low throughputs and the high cost of the precious raw materials makes the use of optical concentrators necessary to improve the cost-performance ratio on the system level. Even if the cost could be reduced, concentrators would still be necessary to achieve a saturated voltage even under full sunlight.

SUMMARY OF THE INVENTION

[0008] Prior art solar cell devices need to be improved in order to achieve the anticipated or "theoretical" advantages with regards to efficiency and production costs.

[0009] The object of the present invention is to overcome the drawbacks of the prior art. This is achieved by solar cell structures and the solar cell modules as defined in the independent claims.

[0010] A solar cell structure according to the present invention comprises a nanowire that constitutes the light absorbing part of the solar cell structure and a passivating shell that encloses at least a portion of the nanowire. Preferably the nanowire protrudes from a substrate.

[0011] In a first aspect of the invention, the passivating shell of the solar cell structure comprises a light guiding shell adjacent to the nanowire. Preferably the light guiding shell is of a material with a higher bandgap than the nanowire and preferably the light guiding shell also has an indirect band-gap.

[0012] In a second aspect of the invention, the solar cell structure comprises a plurality of nanowires which are positioned with a maximum spacing between adjacent nanowires which is shorter than the wavelength of the light which the solar cell structure is intended to absorb. Thereby incoming light will experience a so-called "effective medium" defined by the plurality of nanowires.

[0013] In one embodiment of the invention the nanowire comprises at least one segment that forms a bandgap adapted to absorb light in a wavelength region of the solar spectrum. The solar cell structure may also be provided with a plurality of segments wherein each segment is adapted to absorb light in different wavelength regions of the solar spectrum. The plurality of segments is preferably arranged so that the band-gap of each of the segments decreases in a direction away from the intended incoming light and along the longitudinal axis of the nanowire.

[0014] The plurality of segments can be connected in series by means of Esaki diodes or metallic segments.

[0015] Thanks to the invention it is possible to produce high efficiency solar cells at acceptable costs.

[0016] One advantage of the invention is that the solar cell structure allows heterostructures with no need for lattice matching, allowing a large degree of freedom in the choice of materials combinations. In principle there is no limit to the number of different band gaps, i.e. segments in the nanowire,

giving the possibility to absorb the whole useful part of, or a selected portion of, the solar spectrum.

[0017] Due to the small growth area used for each individual wire, there is no need for extremely homogeneous growth over a whole wafer, which relaxes the requirements on the growth system. Also due to the small area, the substrate may be polycrystalline or thin-film silicon, or the like.

[0018] One advantage of the solar cell structure according to the first aspect of the invention is that the light guiding shell directs the light in an orderly fashion through regions of decreasing bandgap, allowing sequential light harvesting.

[0019] Further, the light guide structure provides intrinsic concentration of photons into the nanowire, giving a saturated voltage even under diffuse light conditions.

[0020] A still further advantage afforded by the invention is the possibility to use metallic segments to connect the segments of the nanowire. This is not possible in the prior art planar devices as metallic layers are not transparent. However, in the present invention, with the narrow light absorbing nanowire enclosed by a light guiding shell, non-transparency will have limited negative effect.

[0021] By placing the nanowires sufficiently close together on the substrate according to the second aspect of the invention the advantages of using nanowires is combined with an effective absorption of the light, as the incoming light "sees" the closely packed nanowires as a continuous effective medium.

[0022] Embodiments of the invention are defined in the dependent claims. Other objects, advantages and novel features of the invention will become apparent from the following detailed description of the invention when considered in conjunction with the accompanying drawings and claims.

BRIEF DESCRIPTION OF THE DRAWINGS

[0023] Preferred embodiments of the invention will now be described with reference to the accompanying drawings, wherein:

[0024] FIG. 1 schematically illustrates the part of the AM1.5 solar spectrum that can be theoretically used by a silicon-based solar cell and a GaInP/GaInAs/Ge-based solar cell, respectively, wherein dark areas indicate efficiency loss due to the thermalisation of charge carriers or the transmission of photons;

[0025] FIG. 2a schematically illustrates a solar cell structure according to one embodiment of the present invention;

[0026] FIG. 2b schematically illustrates a solar cell structure comprising a nanowire with a plurality of segments according to one embodiment of the invention;

[0027] FIG. 3 schematically illustrates a solar cell structure in accordance with the present invention wherein a top portion of the nanowire protrudes out from the light guiding shell;

[0028] FIGS. 4a-b illustrate schematically embodiments of the invention, wherein in 4a, the substrate is provided with a diode, and in 4b, the nanowire terminates at the top end of the light guiding shell;

[0029] FIGS. 5a-b illustrate schematically embodiments of the invention, wherein in 5a Esaki diodes, and in 5b metallic segments, are used to interconnect the segments of the nanowire;

[0030] FIG. 6 illustrates schematically a solar cell structure comprising a plurality of nanowires, each multiple pn-junctions, according to one embodiment of the invention;

[0031] FIG. 7 illustrates schematically a solar cell structure with closely spaced nanowires which is adapted to absorb light in an effective medium approach according to the invention;

[0032] FIG. 8 illustrates schematically a solar cell structure comprising single pn-junctions according to one embodiment of the invention;

[0033] FIG. 9 illustrates schematically a solar cell structure comprising multiple pn-junctions according to another embodiment of the invention, and

[0034] FIG. 10 illustrates schematically a solar cell structure comprising a plurality of nanowires placed closely together, wherein each nanowire is enclosed in a high and indirect bandgap material.

DETAILED DESCRIPTION OF EMBODIMENTS

[0035] FIG. 2a schematically illustrates one embodiment of a solar cell structure according to the present invention. A nanowire 205 constitutes the light absorbing part of the solar cell structure and a passivating shell 209 encloses at least a portion of the nanowire 205. Preferably the nanowire protrudes from a substrate 220. The nanowires may protrude substantially perpendicular to the substrate 220 or at an angle.

[0036] Incoming (sun)light 201 is coupled into the nanowire 205 of the solar cell structure. The incoming light generates electron-hole-pairs and preferably the light absorbing part of the solar cell structure, i.e. the nanowire 205, is configured as a pn-junction to establish an electrical field that promotes a current to flow in only one direction through the nanowire 205 between a front contact 203 and a back contact 202. By way of example the front contact 203 and the back contact 202 are respectively, as schematically illustrated in FIG. 2a, electrically connected to a top portion and a base portion of the nanowire 205, respectively, and the light 201 is coupled into the top portion of the nanowire 205.

[0037] One purpose of the passivating shell 209 in accordance with the present invention is to reduce the number of mid-gap surface states on the circumferential surface of the nanowire 205. By using a passivating shell the surface states may be moved away from the conducting nanowire. Another purpose is to insulate the nanowire 205 from the surrounding. In addition, the passivating shell can in some configurations have a more active role in the solar cell structure. The bandgap can be raised or lowered due to compressive or tensile strain or the bands can be bent in order to radially separate holes from electrons. The function of the passivating shell 209 and the above mentioned purposes are more or less important or relevant in various configurations of the solar cell structure.

[0038] In one embodiment of the present invention the passivating shell 209 comprises a light guiding shell adjacent to the circumferential surface of the nanowire 205. Preferably, the nanowire 205 is made of a direct-bandgap material and the light guiding shell 210 is made of a material with high and indirect bandgap. The light guiding shell may constitute the whole passivating shell 210 or may be in the form of an inner shell surrounded by an outer shell which outer shell has the properties described above. Since the light guiding shell is made of an indirect high-bandgap material, no light will be absorbed in this shell and the light guiding shell directs the light along the nanowire 205.

[0039] Referring to FIG. 2b, in a nanowire 205 comprising a semiconductor material photons with a greater energy than the band gap of the semiconductor material can be absorbed. However photons having an energy that substantially exceeds

the bandgap will not only generate electron-hole-pairs but also heat, which gives thermalisation losses and hence has a negative effect on the efficiency of the solar cell. In one embodiment of the present invention the internal structure of the nanowire **205** of the solar cell according to the present invention may comprise one or more segments **215** that each forms a bandgap adapted to absorb light in a pre-determined wavelength region of the solar spectrum. A high energy component of the light will then be absorbed in a segment **215** that forms a bandgap adapted to absorb light in a pre-determined wavelength region that includes this high energy component, while photons having an energy lower than the bandgap of that segment will experience that segment as a transparent waveguide.

[0040] In one embodiment of the present invention the solar cell structure comprises a light absorbing nanowire **205** that has plurality of segments **215** distributed along the nanowire **205**, wherein each of the segments **215** is adapted to absorb light in different wavelength regions of the solar spectrum. Incoming light is adapted to be coupled into a top portion of the nanowire **205**. The plurality of segments **215** is arranged so that the bandgap of each of the segments **215** decreases in a direction from the top portion of the nanowire **205** towards a base portion of the nanowire **205**. In this way stepwise selective absorption and transmission of light is accomplished wherein light having higher energy than the bandgap of one of the plurality of segments **215** is absorbed and the light having lower energy is transmitted to the next segment **215**. The same selective absorption and transmission will then be offered by the next segment with its lower bandgap etc. Accordingly a large portion of the solar cell spectrum can be efficiently utilized with limited thermalisation losses, which gives a high efficiency.

[0041] FIG. *2b* schematically illustrates one embodiment of a solar cell structure of the present invention comprising a nanowire **205** that constitutes the light absorbing part of the solar cell structure and a light guiding shell **210** that encloses at least a portion of the nanowire **205**. Preferably the nanowire **205** protrudes from a substrate **220**. Optionally, the nanowire **205** protrudes from a substrate **220** and comprises a plurality of segments **215** distributed along the nanowire **205**, wherein each of the segments **215** is adapted to absorb light in different wavelength regions of the solar spectrum. A front contact **224** and a back contact are electrically connected to a top portion and a base portion of the nanowire, respectively. As illustrated in FIG. *2b*, the front contact **224** may enclose the top portion of the nanowire **205** and the back contact **225** may be arranged on the substrate **220** on the opposite side of the nanowire **205**. In order to efficiently absorb light, which is coupled into the solar cell structure at the top portion, the plurality of segments **215** is arranged so that the bandgap of each of the segments **215** decreases in a direction from the top portion of the nanowire **205** towards the base portion of the nanowire **205**. The light guiding shell **210** is made of a material with higher bandgap than the light absorbing part of the nanowire **205** and preferably this bandgap is indirect. Thereby the light guiding shell **210** guides the incoming light in a direction from the top portion to the base portion of the nanowire **205** without absorption therein. Accordingly incoming light of longer and longer wavelengths is successively absorbed in each of the segments **215**. Optionally the solar cell structure comprises a dielectric layer covering the substrate surface in a wrap-around configuration about the base portion of the nanowire **205**. Furthermore the solar cell

structure that is illustrated in FIG. *2b* may comprise an outer shell layer with passivating and insulating properties, as described above, that encloses the light guiding shell **210**. Together the light guiding shell and this outer shell layer then constitute a passivating shell of the solar cell structure.

[0042] FIG. *3* schematically illustrates one embodiment of a solar cell structure of the present invention wherein the light-absorbing part is a nanowire **205** protruding from a substrate **220** and partly enclosed by a light guiding shell **210**. A top portion **240** of the nanowire **205** extends out from the light guiding shell **209**. A front contact **224** and a back contact **225** are electrically connected to the top portion **240** and a base portion of the nanowire **205**, respectively. As illustrated in FIG. *3b*, the back contact **225** may be arranged on the substrate **220** on the opposite side of the nanowire **205** and the front contact **224** encloses the top portion **240**. The front contact **224** may be a metal grid contacting the top portion **240** of the nanowire **205** or a transparent contact covering the entire solar cell structure. In addition the top portion **240** of the nanowire **205** that extends above the light guiding shell **210** may be doped to further enhance contact properties. Preferably, the nanowire **205** comprises direct-bandgap materials and the light guiding shell **210** is made of at least one indirect-bandgap material with a higher bandgap than the direct-bandgap materials of the nanowire **205** in order to obtain a light guiding function from the light guiding shell **210**. The nanowire **205** comprises a plurality of segments **215** that each forms a bandgap adapted to absorb light in a pre-determined wavelength region of the solar spectrum. Preferably, the plurality of segments **215** is arranged so that the bandgaps formed by the segments **215** successively decrease in a direction from the top portion **240** of the substrate **220** and along the nanowire **205** towards the base portion. In use the incoming light is coupled into the solar cell structure and firstly high energy photons are absorbed, then photons with successively lower energy are successively absorbed in segments **215** as they travel towards the base portion of the nanowire **205**. Since the light is guided by the light guiding shell **210** the nanowire may be non-transparent in parts. The segments **215** may be connected in series by means of for example Esaki diodes **216** or short metallic segments.

[0043] The nanowire technology allows the formation of heterostructures, such as the internal structure of the nanowire **205** that is formed by the plurality of segments **215**, with no need for lattice matching, which gives a large degree of freedom in material combinations. Hence band gaps for the absorption of practically any wavelength region of the solar spectrum can be accomplished in the nanowire **205** (which cannot readily be made using prior art planar technology). In principle there is no limit to the number of different band gaps of the segments **215** of the nanowire **205** according to the present invention and hence light from a large portion of the solar cell spectrum can be absorbed.

[0044] The light guiding shell **210** is preferably epitaxially connected to the nanowire **205** by radial growth of the light guiding shell onto the nanowire **205**.

[0045] In one embodiment of the present invention the solar cell structure comprises a nanowire **205**, which preferably is in the center of the light guiding shell **210**. The light guiding shell **210** is made of an indirect high-bandgap material and is sufficiently narrow to allow only single mode light propagation, and the nanowire is small in comparison. The function of the solar cell structure according to this embodiment is as follows: Light is coupled into the solar cell structure at the top

portion **240** of the nanowire **205**. Since the light guiding shell **210** is an indirect high-bandgap material, no light will be absorbed here, and since the light guiding shell is single-mode, the field is strongest in the core, i.e. at the position of the nanowire **205**. As light travels downward, higher energies are efficiently absorbed, while photons with energies lower than the band gap will experience only a transparent waveguide. As the energy bands are sequentially skimmed off in the nanowire **205**, the photons give rise to a photo-voltage in each segment **215**, the photo-voltage being equal to the band gap in that segment. Ideally, the structure will be so efficient that only low-energy light penetrates to the substrate. However, the substrate may also comprise a standard photodiode to collect stray higher-energy photons and generate a photo-voltage.

[0046] The substrate **220** of the solar cell structure of the present invention may either function simply as a mechanical support and electrical contact, as illustrated in FIG. 3, or it may also contain one or more electrically active components, for example a standard photodiode structure. One embodiment of such a solar cell structure with a photodiode, realized by oppositely doped regions **222,223**, by way of example a p-doped region **222** and subsequent n-doped region, in the substrate **220** is schematically illustrated in FIG. 4a.

[0047] FIG. 4b illustrates another embodiment of a solar cell structure according to the present invention wherein the nanowire **205** ends at, or near to, the top of the light guiding shell **210**. Possibly, but not necessarily, the nanowire **210** ends with a cap **250** of the catalytic particle which is typical for some nanowire growth methods. This arrangement is most suitable for use with flat, preferably transparent front contacts.

[0048] The light guiding shell **210** can be interpreted as being a waveguide although it is not limited to operating as a single mode waveguide. The light guiding shell **210** directs or guides the light in an orderly fashion through regions of decreasing bandgap, which enables sequential light harvesting. Moreover the light guiding **210** shell prevents losses due to absorption at the circumferential surface of the nanowire **205** and due to transmission of light out from the solar cell structure.

[0049] FIG. 5a illustrates schematically an enlargement of the nanowire **205**, showing the segments **215** and the Esaki-diodes **216**, with p- and n-type regions inside the segments. FIG. 5b illustrates schematically an embodiment of the invention wherein the Esaki-diodes, which commonly are used in prior art planar tandem cells, are exchanged for metallic segments **217**. This is possible since in the solar cell structure according to the invention the need for transparency in the nanowire **205** is reduced.

[0050] A solar cell module or solar cell panel according to the present invention typically comprises a large number of the above described solar cell structures which preferably are densely packed on the substrate or wafer, so as to cover substantial part of the surface of the substrate or wafer. The solar cell module may comprise one wafer, but a plurality of wafers interconnected to give a required power production is also possible.

[0051] One advantage with the solar cell structures according to the present invention over prior art solar cells fabricated using planar technology is that these structures can be grown in much simpler systems than normal MOCVD. Furthermore, in principle materials with band gaps all through the solar spectrum can be incorporated in the nanowire. Hence the

substrate can be used as a support structure only. Due to the small growth area required for each nanowire **205**, there is no need for extremely homogeneous growth over a whole wafer, which relaxes requirements on growth system. Also due to the small area, the substrate may be polycrystalline or thin-film silicon, or something even simpler.

[0052] The light guiding shell arrangement provides intrinsic concentration of photons into the core, which can also give a saturated voltage even under diffuse light conditions.

[0053] Referring to FIG. 6, according to one embodiment of the present invention a solar cell structure is provided that comprises nanowires **205** with a plurality of vertical pn-junctions, wherein upper pn-junctions form a high bandgap section and lower pn-junctions form a lower bandgap section. The sections are preferably separated by Esaki tunneling diodes. A light guiding shell **210** encloses the nanowires **205** and a passivating and insulating material preferably fills the volume between the nanowires. For example the tunnel diode layers can be heavily doped AlGaAs, GaAsP or GaInP.

[0054] This combination of materials with different lattice-constants would be difficult to achieve using planar technology wherein lattice matching is required. Since in the present invention lattice matching is of minor concern (as it otherwise hinders this kind of development when using traditional planar epitaxial growth methods) this approach can be extended to more junctions in the future. For a dual junction solar cell the bandgap of the top segment (sub-cell) should ideally be in the range of 1.6-1.8 eV and the bottom segment (sub-cell) in the range of 0.9-1.1 eV. These bandgap energies can be reached by using GaAsP, or GaInP for the top segment and GaInAs, or InAsP for the bottom segment. The entire energy range spanned by these material combinations for energy harvesting covers 0.4 eV (InAs) to 2.24 eV (GaInP).

[0055] In the light guide arrangement according to the present invention the width d of the light guiding shell, as indicated in FIG. 6, is larger than the wavelength λ divided by its refractive index n . Preferably the width d is larger than 500 nm. The light guiding shell **209** directs the light along the nanowire through reflections. As illustrated in the figure the passivating shell **209** may be a matrix that fills the volume between the nanowires.

[0056] One example of a specific embodiment of a solar cell structure in accordance with the present invention has a photonic light guiding design, created via the radial growth of a fully transparent high refractive index shell, like AlN, that functions as a total light guiding structure of about 0.5 μm diameter of which about 100 nm is a multiple-bandgap core structure. The top portion (about 0.5 μm) of the nanowire **205** will, due to the dense arrangement of the elongated nanowires, capture the incoming flux of light, which is then transmitted downwards in a fashion such that the high-energy component will be captured in the top-segment which looks just like the fully transparent wave-guide for all photon energies below its bandgap. The same selective absorption and transmission will then be offered by the next segment with its lower bandgap etc. Above the top selected band-gap segment is a long, heavily n-doped GaN segment used for contacting. The bottom segment may be made from InN and intermediate segments comprise increasing fractions of Ga up to the top segment with a composition of about $\text{Ga}_{0.7}\text{In}_{0.3}\text{N}$. The substrate will in this case provide support and a back contact, since the lowest bandgap will be at the bottom of the nanowire. A possible other material combination is AlGaInAsP. In this materials system, there are direct bandgap materials with

values between 0.4 eV up to 2.25 eV, hence competing very well with the state-of-the-art for multi junction cells. In this case the lower segments may be formed in the well established $\text{InAs}_{1-x}\text{P}_x$ system, and the upper segments e.g. in the $\text{Ga}_x\text{In}_{1-x}\text{P}$ system, with the top segment of Ga-rich (70%) GaInP having a direct bandgap of 2.25 eV. These are material combinations that have not been accessible using conventional planar technology methods where lattice matching is required.

[0057] Controlled absorption of (sun)light using a nanowire-based solar cell structure according to the invention can also be obtained with another approach, which can be referred to as an “effective medium”-like concept. An “effective medium” is usually described as structures containing different materials on length-scales considerably less than the wavelengths of the incident light. This concept can be seen as a replacement of the commonly used absorption in continuous films by the optical effects of absorption by a dense arrangement of preferably parallel nanowires, spaced by distances substantially smaller than the wavelength of the incident light (that is intended to be absorbed).

[0058] One embodiment of a solar cell structure according to the present invention comprises a plurality of nanowires that constitute the light absorbing part of the solar cell structure. The nanowires optionally protrude from a substrate and are provided with a maximum spacing between adjacent nanowires which is shorter than the wavelength of the light which the solar cell structure is intended to absorb in order to obtain the “effective medium” effect. Preferably a passivating shell of a material with a high and indirect bandgap encloses at least a portion of the nanowires. The passivating shell may completely fill the spacing between the nanowires.

[0059] The internal structure of the nanowires may comprise one or more segments that each forms a bandgap adapted to absorb light in a pre-determined wavelength region of the solar spectrum. By providing segments having different bandgaps, each segment is adapted to absorb light in a different wavelength region of the solar spectrum.

[0060] In one embodiment of the present invention the solar cell structure comprises a plurality of nanowires that are provided on the substrate with a maximum spacing between adjacent nanowires which is shorter than the shortest wavelength of said different wavelength regions.

[0061] FIG. 7 schematically illustrates the “effective medium” concept, wherein a) schematically illustrates a conventional multi junction photovoltaic device fabricated using planar technology wherein a plurality of layers **741**, **742**, **743**, **744**, **745**, **746** form segments which absorb different parts of the incoming light, indicated with the thick arrow. As described in the background forming such multilayer structures with appropriate material combinations is exceedingly hard and requires the use of expansive III-V substrates **720**. FIG. 7b illustrates schematically the solar cell structure according to one embodiment of the present invention, comprising a matrix of densely packed nanowires **705**, with a maximum nanowire spacing D, i.e. the centre-to-centre distance, which is smaller than the shortest wavelength that the device is designed to absorb. Incoming photons will “see” the dense array as a sequence of quasi-continuous absorbing layers while the generated electrons and holes will be strictly collected by the vertical nanowire structures. This approach allows standard geometries for PV-cell illumination, ensuring the sequential absorption characteristics required for the highest PV efficiencies.

[0062] The maximum spacing D between adjacent nanowires is below 400 nm, preferably below 200 nm and even more preferably below 150 nm. The width of the nanowires in this embodiment is typically in the order of 100 nm. The maximum spacing D can also be related to the wavelength λ of the light and the effective refractive index n_{eff} of the nanowire material. Preferably the maximum spacing D is less than λ/n_{eff} . The substrate **720** is preferably a silicon substrate, and the nanowires **705** are preferably grown from the substrate.

[0063] Referring to FIG. 8, according to one embodiment of the invention a solar cell structure is provided comprising nanowires **705** with a vertical single pn-junction. The substrate **720** may be p-type III-V wafers such as InP or GaAs substrates as illustrated schematically in the figure, but silicon substrates are in many cases a preferred choice. For contacting the upper-top n-conducting regions, a conducting transparent film may be deposited over the entire structure since the regions in between the n-doped nanowire regions are covered by an insulating and surface passivating dielectric mask, e.g., SiO_2 , which constitutes the passivating shell **709** that encloses the nanowires **705**.

[0064] Referring to FIG. 9, according to one embodiment of the present invention a plurality of pn-junctions forming segments **715** are provided in an effective medium architecture. The figure schematically illustrates a tandem photovoltaic cell with embedded Esaki tunneling diodes **716** and a surrounding passivating shell **709**. By choosing the nanowires **705** length, width (diameter) and density to be sufficiently high this geometry will ensure that substantially all incoming radiation will be absorbed by the nanowires **705**. On top of the dual junction, a segment of indirect-bandgap material can be grown in order to enhance the light absorption efficiency for the light guide approach. The nanowire absorption of photons having energies exceeding the band gap of the material selected may be high and a wavelength dependent penetration depth can be expected.

[0065] The passivating shell **709** in the embodiments based on the effective medium concept is mainly for passivation and insulation. However, this passivating shell **709** may comprise a light guiding shell as described in the other embodiments of this description. FIG. 10 schematically illustrates one embodiment of a solar cell structure according to the present invention comprising a plurality of nanowires **705** protruding from a substrate **720**. The nanowire **705** comprises a plurality of pn-junction forming segments **715** separated by Esaki tunneling diodes **716**. The nanowires **705** are closely packed, i.e. with a maximum spacing D between nanowires that is shorter than the wavelength of the light which the solar cell structure is intended to absorb. Preferably the top portion **740** of the nanowire comprises a highly doped segment to obtain a low contact resistance for the front contact. As mentioned above the passivating shell **709**, which completely fills the volume between the nanowires, comprises a light guiding shell **709**.

[0066] For the realization of high-efficiency multi junction photovoltaic cells based on nanowires, it is proffered that the light absorption occurs in the proper sequence, hence a random absorption in the different materials sections should be avoided. In the embodiments described above this sequential absorption is achieved using core-shell structures by which light is guided from the top to the bottom end of the nanowires.

[0067] Although the solar cell structures of the invention have been described as being adapted for coupling of light

into the nanowire through the front contact or a top portion, the invention it is not limited to this. The incident light may also be transmitted into the nanowires through the substrate. In such cases the segments should be arranged with the highest energy absorbing segment nearest the substrate. Furthermore, the substrate may be thinned down or even removed.

[0068] The embodiments that comprise a plurality of segments 215,715 are not limited to segments 215,715 where each is adapted to absorb light in different wavelength regions of the solar spectrum. A nanowire 205,705 of the solar cell structure may comprise two or more segments 215,715 which are adapted to absorb light in the same pre-determined wavelength region of the solar spectrum. This can be used to step up the voltage output of the solar cell structure.

[0069] While the present invention is described in the context of multi junction PV-applications it is expected to find use in other areas of opto-electronics, such as for photodetectors. As appreciated by the skilled in the art the here described embodiments of the invention can be combined in various ways.

[0070] Suitable materials for the substrate include, but are not limited to: Si, GaAs, GaP, GaP:Zn, InAs, InP, GaN, Al₂O₃, SiC, Ge, GaSb, ZnO, InSb, SOI (silicon-on-insulator), CdS, ZnSe, CdTe. Suitable materials for the nanowires and nanowire segments include, but are not limited to: GaAs, InAs, Ge, ZnO, InN, GaInN, GaN AlGaInN, BN, InP, InAsP, GaP, GaAsP, GaInP, GaInAs, AlInP, GaAlInP, GaAlInAsP, GaInSb, InSb, Si. Possible donor dopants are Si, Sn, Te, Se, S, etc, and acceptor dopants are Zn, Fe, Mg, Be, Cd, etc. Suitable materials for the passivating and light guiding shell include, but are not limited to: AlN, GaN, InN, AlGaInN, BN, SiC, GaP, GaAsP, AlAs, AlP, AlSb, AlAsP, GaAlAs, GaAlAsP, AlInP, SiO₂, Al₂O₃, ZnO, SiN, HfO₂, ZrO₂, ZnCdTeSeS, glass, organic polymers, etc. It should be noted that the use of the herein described nanowire technology makes it possible to use nitrides such as GaN, InN and AlN.

[0071] While the invention has been described in connection with what is presently considered to be the most practical and preferred embodiments, it is to be understood that the invention is not to be limited to the disclosed embodiments, on the contrary, it is intended to cover various modifications and equivalent arrangements within the scope of the appended claims.

1-21. (canceled)

22. A solar cell structure comprising at least one nanowire that constitutes a light absorbing part of the solar cell structure; and a light guiding shell that encloses at least a portion of the nanowire and is adapted to direct incoming light along the nanowire and through the light absorbing part of the solar cell structure.

23. The solar cell structure according to claim 22, wherein the nanowire is made of a material with a direct bandgap.

24. The solar cell structure according to claim 22, wherein the light guiding shell is made of a material with a higher bandgap than the segment.

25. The solar cell structure according to claim 22, wherein the light guiding shell is made of a material with an indirect bandgap.

26. The solar cell structure according to claim 22, wherein the nanowire comprises at least one segment made of a material with a first bandgap that is adapted to absorb light in a wavelength region of the solar spectrum with photons having a larger energy than the first bandgap.

27. The solar cell structure according to claim 26, wherein the segment comprises a pn-junction.

28. The solar cell structure according to claim 26, wherein the nanowire comprises a plurality of segments and each segment has a different bandgap in order to absorb light in different wavelength regions of the solar spectrum.

29. The solar cell structure according to claim 28, wherein the plurality of segments is arranged so that the different bandgaps of the segments decrease in a direction away from intended incoming light and along the nanowire.

30. The solar cell structure according to claim 28, wherein the segments are connected in series by means of Esaki diodes.

31. The solar cell structure according to claim 28, wherein the segments are connected in series by means of metallic segments.

32. The solar cell structure according to claim 22, wherein the light guiding shell is sufficiently narrow to allow only single-mode light propagation and the nanowire diameter is smaller than the light guiding shell thickness.

33. The solar cell structure according to claim 22, wherein a width of the light guiding shell is larger than a wavelength of the incoming light divided by a refractive index of the light guiding shell.

34. The solar cell structure according to claim 22, wherein the substrate comprises a photodiode structure formed by oppositely doped regions in the substrate adjacent to the nanowire.

35. The solar cell structure according to claim 22, wherein the nanowire protrudes from a substrate.

36. The solar cell structure according to claim 22, wherein an outer shell layer with passivating and insulating properties encloses the light guiding shell.

37. The solar cell structure according to claim 22, wherein the light guiding shell is epitaxially connected to the nanowire.

38. The solar cell structure according to claim 22, wherein a top portion of the nanowire extends from the light guiding shell, and a front contact encloses the top portion.

39. The solar cell structure according to claim 22, comprising a plurality of nanowires which are positioned with a maximum spacing between adjacent nanowires which is shorter than the wavelength of the light which the solar cell structure is intended to absorb.

40. A solar cell structure comprising a plurality of nanowires that each constitutes a light absorbing part of the solar cell structure and a maximum spacing between adjacent nanowires is shorter than the wavelength of the light which the solar cell structure is intended to absorb such that incoming light will experience an effective medium.

41. The solar cell structure according to claim 40, wherein each nanowire comprises a plurality of segments and each segment has a different bandgap in order to absorb light in different wavelength regions of the solar spectrum and the plurality of segments is arranged so that the different bandgaps of the segments decrease in a direction away from intended incoming light and along the nanowire.

42. The solar cell structure according to claim 41, wherein the maximum spacing between adjacent nanowires is shorter than 400 nm.

43. The solar cell structure according to claim 42, wherein the maximum spacing between adjacent nanowires is shorter than 150 nm.