

(19) World Intellectual Property Organization
International Bureau



(43) International Publication Date
12 February 2009 (12.02.2009)

PCT

(10) International Publication Number
WO 2009/021232 A2

- (51) International Patent Classification: A61K 48/00 (2006.01)
 - (21) International Application Number: PCT/US2008/072768
 - (22) International Filing Date: 11 August 2008 (11.08.2008)
 - (25) Filing Language: English
 - (26) Publication Language: English
 - (30) Priority Data: 60/954,903 9 August 2007 (09.08.2007) US
 - (71) Applicant (for all designated States except US): MASSACHUSETTS INSTITUTE OF TECHNOLOGY [US/US]; 77 Massachusetts Avenue, Cambridge, MA 02139-4307 (US).
 - (72) Inventors; and
 - (75) Inventors/Applicants (for US only): YANIK, Mehmet, Fatih [TR/US]; 100 Memorial Drive, Apt 8-19b, Cambridge, MA 02142 (US). ROHDE, Christopher [CA/US]; 611-70 Pacific Street, Cambridge, MA 02139 (US). AN-GEL, Matthew [US/US]; 8 Museum Way, #2204, Cambridge, MA 02141 (US). GILLELAND, Cody [US/US]; 2518 Denmark Drive, Garland, TX 75040 (US). ZENG, Fei [CA/US]; 19938 Portal Plaza, Cupertino, CA 95014 (US).
 - (74) Agent: PASTERNAK, Sam; Choate, Hall & Stewart Llp, Two International Place, Boston, MA 02110 (US).
 - (81) Designated States (unless otherwise indicated, for every kind of national protection available): AE, AG, AL, AM, AO, AT, AU, AZ, BA, BB, BG, BH, BR, BW, BY, BZ, CA, CH, CN, CO, CR, CU, CZ, DE, DK, DM, DO, DZ, EC, EE, EG, ES, FI, GB, GD, GE, GH, GM, GT, HN, HR, HU, ID, IL, IN, IS, JP, KE, KG, KM, KN, KP, KR, KZ, LA, LC, LK, LR, LS, LT, LU, LY, MA, MD, ME, MG, MK, MN, MW, MX, MY, MZ, NA, NG, NI, NO, NZ, OM, PG, PH, PL, PT, RO, RS, RU, SC, SD, SE, SG, SK, SL, SM, ST, SV, SY, TJ, TM, TN, TR, TT, TZ, UA, UG, US, UZ, VC, VN, ZA, ZM, ZW.
 - (84) Designated States (unless otherwise indicated, for every kind of regional protection available): ARIPO (BW, GH, GM, KE, LS, MW, MZ, NA, SD, SL, SZ, TZ, UG, ZM, ZW), Eurasian (AM, AZ, BY, KG, KZ, MD, RU, TJ, TM), European (AT, BE, BG, CH, CY, CZ, DE, DK, EE, ES, FI, FR, GB, GR, HR, HU, IE, IS, IT, LT, LU, LV, MC, MT, NL, NO, PL, PT, RO, SE, SI, SK, TR), OAPI (BF, BJ, CF, CG, CI, CM, GA, GN, GQ, GW, ML, MR, NE, SN, TD, TG).
- Published:
— without international search report and to be republished upon receipt of that report

(54) Title: HIGH-THROUGHPUT, WHOLE-ANIMAL SCREENING SYSTEM

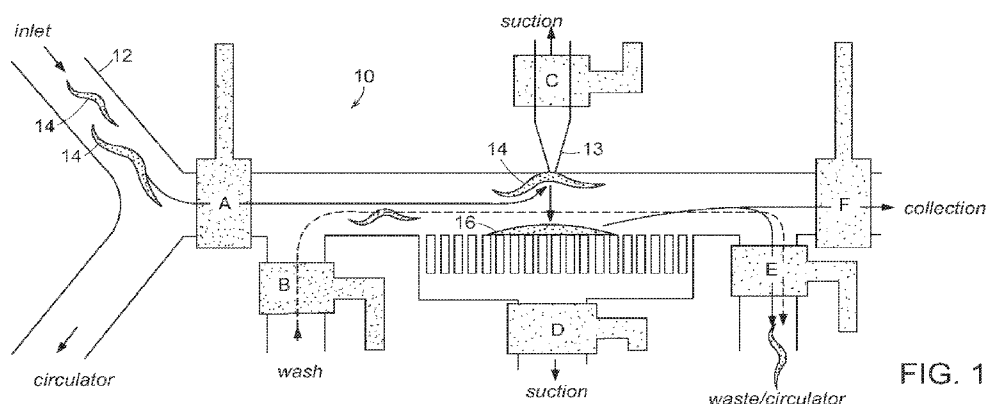

FIG. 1A

(57) Abstract: Distinctive components that enable high-throughput, whole-animal screening are described. These components can be used individually or in various combinations. A staging chip strains off the excess fluid that the input animals are immersed in, increasing their density (number of animals in a given volume) and rapidly bringing them close to other fluidic components. A microfluidic sorter is adapted to isolate and immobilize a single, physiologically active animal in a selected geometry. A multiplexed micro-chamber chip receives single animals and the microchamber chip includes individually addressable screening chambers for imaging, incubation and exposure of individual animals to selected chemical compounds. An imaging structure generates sub-cellular, high-resolution images of the physiologically active animals. A well-plate interface chip is used to deliver elements from a compound library to a single output of the chip.

WO 2009/021232 A2

HIGH-THROUGHPUT, WHOLE-ANIMAL SCREENING SYSTEM

Priority Claim

This application claims priority to U.S. Provisional Patent Application Serial No. 60/954,903, filed August 9, 2007, the contents of which are incorporated herein by reference.

Background of the Invention

This invention relates to high-throughput screening using small-animal models. This technology can be applied to study neurotoxicity, neural degeneration, regeneration, neurological disorders, Alzheimer's disease, Parkinson's disease, wound healing, the immune system, metabolism, aging, development, stem cells, reproduction, heart diseases, vascular, liver, kidney, bladder, intestinal or tooth development. Potential applications include drug screening and discovery, population enrichment, genetic screening, and target and lead validation.

Existing large vertebrate animal models currently cannot be used in high-throughput assays for rapid identification of new genes and drug targets because of the size and complexity of the instrumentation with which these models are studied. In recent years, the advantages of using small invertebrate animals as model systems for human disease have become increasingly apparent, and have resulted in two Nobel Prizes in Physiology or Medicine during the last six years for studies conducted on the nematode *C. elegans*. The availability of a wide array of species-specific genetic techniques, along with the worm's transparency, and its ability to grow in minute volumes make *C. elegans* an extremely powerful model organism. The use of small vertebrate animals is exemplified in studies of zebrafish (*D. rerio*). Like *C. elegans*, zebrafish are transparent, develop quickly, and a wide range of genetic controls are available. Additionally, being vertebrates, zebrafish are more closely related genetically to humans, thus increasing the likelihood that any discovered process is conserved between the two.

However, the techniques to manipulate both *C. elegans* and zebrafish have not evolved with their respective fields. These manipulations are primarily manual, and performed on individual worms or fish. As a result, large-scale assays such as mutagenesis and reverse genetic screens (1-3) can take months or even years to complete manually. For example, high-throughput *C. elegans* assays are currently performed by adapting techniques developed for screening cell lines, such as flow-through sorters and microplate readers (4-6). Due to the significant limitations of these methods, high-throughput small-animal studies either have to be dramatically simplified before they can be automated or cannot be conducted at all. The numbers in parentheses refer to the references appended hereto. The contents of all of these references are incorporated herein by reference.

Existing small-animal sorters such as the BIOSORT and XL from COPAS use a flow-through technique similar to the fluorescence-activated cell sorter (FACS) technology. These systems can capture and analyze only one-dimensional intensity profiles of the animals being sorted and as a result, three-dimensional cellular and sub-cellular features cannot be resolved (13).

Although microfluidics have previously been used to perform novel assays on *C. elegans*, so far research has been limited to specific applications such as generation of oxygen gradients (7), worm culturing/monitoring during space flight (8), optofluidic imaging (9) and maze exploration (10). *See also*, U.S. Patent Number 6,400,453.

Heretofore, accurate control of the nematode's or fish's microenvironment has not been possible. Such microenvironment control is necessary for making quantitative, artifact free, and repeatable measurements. Conventional techniques involve many manual steps wherein worms are exposed to different temperatures, abrupt and inaccurately timed changes. Manual handling is also error prone. All of these factors not only slow down assays dramatically, but also cause artifact errors.

It is therefore an object of the present invention to provide a high-throughput screening system for use with small-animal models.

Summary of the Invention

In one aspect, the invention is a high-throughput, whole-animal screening system including a microfluidic sorter adapted to isolate and immobilize a single, physiologically active animal in a selected geometry for phenotype determination. Animals are introduced from a multi-well plate or a reservoir either directly into the sorter or into an on-chip staging area. Following immobilization, imaging, and/or manipulation in the sorter, a multiplexed micro-chamber chip receives the animal. The micro-chamber chip includes individually addressable screening chambers for exposure of individual animals to selected chemical compounds. An imaging structure is provided for generating sub-cellular, high-resolution images of the physiologically active animals. A well-plate interface chip is used to deliver compounds from a library to either the sorter or the micro-chamber chip. In a preferred embodiment, the sorter includes first suction means for immobilizing a single animal and fluid means for flushing additional animals from the sorter, either to a waste line, or back towards the input or staging area. A second suction means is provided for immobilizing the animal in the selected geometry for screening phenotype features. A layer above the main chamber in the sorter and the screening chambers that can be pressurized is provided to immobilize animals in the selected geometry for even greater stability. Fluidic means are provided for delivering the animal to the micro-chamber chip.

In another preferred embodiment, the multiplexed micro-chamber fluidic chip includes a plurality of micro-chambers, each micro-chamber including multiple barriers or posts arranged in a curved configuration to capture an animal for high resolution imaging. The preferred imaging structure includes a femtosecond two-photon capability.

It is preferred that the small animal be a nematode, such as *C. elegans* or be a small vertebrate, such as zebrafish.

Brief Description of the Drawing

Fig. 1A is a schematic diagram illustrating an embodiment of a sorter used in the invention here showing the flow of a nematode through the device.

Fig. 1B is a cross-sectional view of a valve used in an embodiment of the invention.

Fig. 2A and 2B are photomicrographs of an embodiment of the sorter of the invention.

Fig. 2C is a schematic illustration of a *C. elegans* worm showing touch neurons.

Figs. 3A, B, C and D are photomicrographs showing an embodiment of the multiplexed micro-chamber fluidic chip of the invention.

Fig. 4A is a cross-sectional view of an embodiment illustrating aspects of the multi-well-plate interface chip.

Fig. 4B is a perspective view of the multi-well-plate interface chip.

Figs. 5A and 5B are schematic, perspective views of embodiments according to the invention.

Fig. 6 is a schematic illustration of an embodiment using electroporation for toxin introduction.

Figs. 7(a), 7(b) and 7(c) are schematic illustrations of another embodiment of the invention utilizing a flexible membrane to fully immobilize an animal.

Figs. 8(a) and 8(b) are schematic illustrations of an embodiment of the invention particularly suited to immobilize zebrafish.

Fig. 9 is a schematic diagram illustrating an embodiment of a sorter with a staging area prior to the sorter.

Description of the Preferred Embodiment

The present invention utilizes small animals for high-throughput screening of biologically active materials. A preferred small animal is a nematode such as *C. elegans* or the embryos or larva of a zebrafish. Other animals that may be used in embodiments of the invention include, *Saccharomyces cerevisiae* (yeast), *drosophilla* (eggs), and other nematodes. The present disclosure will focus on *C. elegans*, but it should be noted that wherever *C. elegans* is mentioned, other small animals may be used. *C. elegans* is a preferred animal for several reasons. This animal, approximately 50 μm in diameter, can be micro-manipulated inside microfluidic chips and can be directly exposed to harsh ambient environments. This animal can survive a wide range of environmental stress, temperature ranges, pH conditions, and salinity. These animals can be kept alive for months without feeding.

The *C. elegans* worm is optically transparent so that the fate of every single cell type in the worm can be tracked through bright-field and fluorescent microscopy *in vivo*. The animals can be easily genetically engineered for fluorescent labeling of specific types of neurons. These animals possess all of the major neuronal cell types found in higher organisms including acetylcholine, glutamate, GABA, serotonin, and dopamine neurons. Models of Alzheimer's and Parkinson's diseases exist in the *C. elegans* system. Unknown cell-specific toxins can be classified by identifying the type of cells that they affect by both behavioral and morphological assays.

C. elegans has a simple enough neuronal network that there is a one-to-one map between behavioral response of the worm and the viability of specific cells. Genetic and behavioral compensatory mechanisms due to redundant pathways that exist in higher organisms are not present in *C. elegans*. Thus, the phenotypic effects are very easy to detect.

The *C. elegans* organism is self-fertilizing (Hermaphrodite) such that every worm has an identical genetic sequence (apart from any low-probability mutations). Therefore, quantitative assays can be performed correlating measurements at different time points and environments. Simple genetic manipulation techniques allow individual genes controlling specific pathways to be turned on and off selectively. This manipulation can allow rapid detection of specific biological pathways. *C. elegans* also develops quickly (three days) and has a long life span of up to three months.

With reference to Fig. 9, a staging area is composed of multiple suction channels and a plurality of microfluidic valves. Accumulating multiple animals in the staging area allows simplified tracking. With reference to the sorter designs of Fig. 1, animals still occupying the main chamber when one animal is captured by the single suction valve can be washed back to the staging area, ensuring all animals are processed and can be tracked. In the preferred embodiment, input to the staging area can be accomplished using the interface device of Fig. 4, or simply by aspirating from a reservoir or a well in a multi-well plate. The aspiration tip can be placed either manually or automatically using a computer-controlled positioning apparatus.

With reference now to Fig. 1A, a sorter 10 according to one embodiment of the invention includes an inlet 12 through which pass *C. elegans* worms 14. Fluid flow through the sorter 10 is controlled by valves labeled A, B, C, D, E and F. Fig. 1B illustrates an open and closed valve that utilizes a flexible membrane to close the valve (18).

Returning to Fig. 1A, when the valve A is opened worms flow into the sorter 10. Suction is applied through a microchannel 13 controlled by a valve C so that when the valve C is open a worm may be captured. The use of the single microchannel 13 eliminates the potential problem of simultaneously capturing multiple animals. Once an animal 14 is captured, valves B and E are opened establishing a flow that will sweep any other animals out of the sorter, either by continuing the flow out of the chamber, or flowing the animals back towards the input area or staging area. Upon completion of this flushing operation, valve C is closed and valve D is

opened to additional suction so that the animal 14 comes to rest on a surface 16 formed by an array of suction channels. The worm 14 will be immobilized in a straight position as shown. At this point, the worm is imaged through a transparent glass or polymer substrate using high-resolution optics for phenotype analysis (see element 24 in Fig. 5A.) Fig. 2A is an image of the on-chip sorter described above in conjunction with Fig. 1A. The scale bar is 500 μm . Fig. 2B shows a single worm trapped by multiple suction channels. A combined white-light and fluorescence image is taken by a cooled CCD camera (Roper Scientific) with 6.5 μm pixels and a 100ms exposure time through a 0.45 NA 10x objective lens (Nikon). Clearly visible are mec-4::GFP-expressing touch neurons and their processes (scale bar 10 μm). Fig. 2C shows touch neurons PLML/R and ALML/R (L, left; R, right), which extend processes along the anterior and posterior half of the worm and contribute to mechanosensation in these regions. The cell bodies are shown as black dots. Three-dimensional cross-sectioning by two-photon microscopy can also be used at the expense of sorting speed.

To achieve greater immobilization, a microfluidic valve layer can be placed above the main chamber of the sorter. Fig. 7 shows this process. Once the worm is held by the suction channels, the valve line above the sorter is pressurized. This causes expansion of the membrane separating the layers, which immobilizes the animal against the multiple suction channels. Fig. 7B and Fig. 7C show photomicrographs of an animal immobilized by an embodiment of this concept.

The microfluidic-chip sorter 10 of Fig. 1A has flow and control layers, and is permanently bonded onto a glass substrate to allow optical access, though it could also be bonded to another layer of transparent polymer. Flow layers are made by casting a room-temperature-vulcanizing dimethylsiloxane polymer (RTV615, GE Silicones) using a mold including patterned layers of negative photoresist (SU8-2025, Microchem) and positive photoresist (SIPR-7123, Shin-Etsu) on a silicon wafer. It is preferred that the main flow layer channels have a width in the range of 250-500 μm and are 80-110 μm high. The channels are rounded by reflowing the developed photoresist at 150° C. In a preferred embodiment, the flow layer includes suction channels defined using a layer of negative photoresist and that the

channels are 25 μm high and 15 μm wide to allow capturing of animals. Control layers are made by casting from a mold including a patterned layer of negative photoresist (SU8-2050, Microchem) on a silicon wafer. Control channels are 70-80 μm high and the membrane that separates the two layers is 10-20 μm thick. PDMS chips cost significantly less than current flow-through animal-screening machines and can be easily incorporated into a variety of microscopy systems.

The speed of the sorter 10 depends on the actuation speed of the valves, the concentration of animals at the input, the flow speed of the worms, and the image acquisition and processing times. The technique of immobilizing worms by lowering pressure in a micro-channel is fast because the actuation speed of the valves is less than 30 milliseconds. Because of continuous recirculation at the input, animals can be flowed at high concentration without clogging the chip. The speed of image acquisition and recognition of sub-cellular features is fundamentally limited by the fluorescence signal-to-noise ratio and the complexity of the features being recognized. The entire worm can be imaged in a single frame using a low magnification, high-NA objective lens. Cellular and sub-cellular features (touch-neuron axons, etc.) can be detected by wide-field epi-fluorescence wherein the exposure times are limited by the brightness of the fluorescent markers. Using a cooled CCD camera allows image acquisition at speeds exceeding one frame every one hundred milliseconds when imaging neurons labeled with green fluorescent protein (GFP).

With reference now to Figs. 3A, B, C and D a multiplexed micro-chamber chip 18 includes a plurality of micro-chambers 20. Inputs to the chambers 20 are controlled through multiplexed control lines and valves. The same inputs can be used to deliver both worms and compounds by flushing the lines with clean media. The micro-chambers 20 include barriers or posts 22 preferably arranged in a curved or circular pattern for capturing and immobilizing the worm 14 that enters the micro-chamber chip 18 upon discharge from the sorter 10. The posts 22 may be arranged in a straight configuration. The posts 22 are preferably arranged in a curved pattern to conserve space to accommodate high-throughput screening. Fig. 3C shows a close-up of a post or barrier 22 and also shows a GFP-labeled fluorescent touch neuron in an animal 14.

Sorted worms from the sorter 10 are delivered to the micro-chambers 20 by opening valves via multiplexed control lines (14). Pressure in the control lines is switched on and off with external electronically controlled valves (Numatics TM series actuators). Since the number of control lines required to independently address N incubation chambers scales only with $\log(N)$ (14), micro-chamber chips based on this design can in theory be readily scaled for large-scale screening applications. Because of the millimeter scale of the micro-chambers, thousands of micro-chambers can be integrated on a single chip. As with the sorter, an additional valving layer can be placed above the individual chambers to improve the immobilization.

Each incubation chamber in this embodiment contains posts or barriers 22 arranged in an arc. To image animals, a gentle flow is used to push the animals toward the posts 22. This flow restrains the animals for sub-cellular imaging without using anesthetics. The arc arrangement of the posts reduces the size of the chambers and also positions the animals in a well-defined geometry to reduce the complexity and processing time of image-recognition algorithms. The media in the chambers can be exchanged through the microfluidic channels for complex screening strategies. Thus, precisely timed exposures to biochemicals (e.g., neurotoxins) can be performed. This capability is useful both for identifying mechanisms that rely on the action of more than one compound, and for combinatorial assays involving multiple drug targets. The use of the microfluidic technology disclosed herein also reduces the cost of whole-animal assays by reducing the required volumes of compounds used.

Interfacing microfluidics to existing large-scale RNAi and drug libraries in standard multi-well plates represents a significant challenge. It is impractical to deliver compounds to thousands of micro-chambers on a single chip through thousands of external fluidic connectors. To address this problem, the inventors herein have designed a microfluidic interface chip shown in Fig. 4A. The device includes an array of aspiration tips that can be lowered into the wells of micro-well plates shown in Fig. 4B. The chip is designed to allow minute amounts of library compounds to be collected from the wells by suction, routed through multiplexed flow lines one at a time, and delivered to the single output of the device. The output of the interface chip would then be connected to the microfluidic-chamber device 18 shown in Fig. 3 for sequential delivery

of compounds to each micro-chamber 20. Combining this multi-well-plate interface chip with existing robotic multi-well-plate handlers will allow large libraries to be delivered to microfluidic chips. The same device can also be used to dispense worms into multi-well plates, simply by running it in reverse.

Since the sorter 10 and micro-chambers 20 disclosed herein are designed to immobilize and release animals repeatedly within few seconds, the on-chip screening technology will allow high-throughput whole-animal assays at sub-cellular resolution and with time-lapse imaging. It is possible to automate a variety of assays by combining these devices in different configurations. For example, mutagenesis screens can be performed using the microfluidic sorter 10 in combination with the microfluidic dispenser to dispense sorted animals at high speeds into the wells of multi-well plates as shown in Fig. 5A. Large scale RNAi and drug screens with time-lapse imaging 24 can be performed by combining the sorter, integrated microchambers, and multi-well plate interface chips as shown in Fig. 5B. Although *C. elegans* is self fertilizing, and has one of the lowest phenotypic variability of multi-cellular organisms (4), variations among assayed animals are still present, reducing the robustness of current large-scale screens. Sorting technology can be used to select animals with similar phenotypes (such as fluorescent-marker expression levels) prior to large-scale assays to significantly reduce initial phenotypic variations (4, 15). The micro-chamber technology disclosed herein can be used with feature-extraction algorithms to screen thousands of animals on a single chip. An interface to multi-well plates can be used to deliver large compound libraries to the micro-chambers. The system disclosed herein will allow hundreds of micro-chambers to be independently and simultaneously conditioned and monitored.

The multiple-input flow control enables both combinatorial and sequential delivery of compounds to individual chambers to allow complex screening strategies to be designed. For example, both prior to and following toxin exposure multiplexed at various stages, RNAi gene silencing can be used to turn off genes to identify biochemical pathways involved in toxicity. The microfluidic-chip system disclosed herein will be continuously kept in a stage-mounted temperature-controlled CO₂/O₂ incubator to allow long-term incubation of animals.

The microfluidic worm-sorter disclosed herein will also allow one to screen mutants from a large number of worm populations mutagenized and/or degenerated by toxins. One of the greatest advantages of the worm-sorter disclosed herein is that it can be interfaced with high-resolution optics easily, allowing sorting of worms accurately and with much finer phenotype analysis.

Several studies indicate that dopaminergic neurons are the neurons most vulnerable to environmental neurotoxins and are especially vulnerable to toxins that target mitochondrial proteins. In particular, it is widely accepted that sporadic Parkinson's disease results from dopaminergic-neuron death induced by environmental toxins. No organism other than *C. elegans* allows non-invasive *in vivo* imaging of its dopaminergic neurons. Thus, observation of dopaminergic neurons in *C. elegans* is very appealing for assessment of neurotoxicity. The inventors have performed an experiment that demonstrates on-chip detection of neurotoxicity due to the well known neurotoxin 6-OHDA. The inventors used genetically engineered worms that express GFP (green fluorescent protein) under the control of dopamine-neuron-specific promoters. Degeneration of neurons by loss of fluorescence after neurotoxin exposure is easily detectable through the transparency of the chip. In order to automatically analyze hundreds of micro-chambers, simple recognition algorithms can be used to track fates of these fluorescently labeled dopaminergic neurons.

Fig. 6 illustrates the use of electroporation to facilitate toxin introduction. This is done by applying an electrical potential across the worm to increase uptake of a toxin or plasmid. The electrical potential can be applied using electrodes patterned onto the substrate, via wires threaded through a pin or using the pins themselves.

The devices disclosed herein generally consist of multiple thin layers of poly(dimethyl siloxane) (PDMS) fabricated by soft lithography (19). The PDMS layers are each fabricated from a separate mold. To fabricate a flow layer suitable for smaller animals, including *C. elegans*, the inventors used a mold with two photoresist layers. First a 15 μm -thick layer of

SU8-2025 negative photoresist (Microchem) was spin-coated and patterned to define the aspiration channels. Next, a 100 μm -thick layer of SIPR-7123 positive photoresist (Micro-Si) was spin-coated and patterned to create the remaining parts of the flow-layer mold. The positive part of the flow layer is rounded by reflowing the developed photoresist at 150°C. The press-down and control-layer molds were created from 65 μm - and 75 μm -thick layers of SU8-2050 (Microchem), respectively. From these molds, RTV-615 PDMS (GE Silicones) was cast. This material was deposited either by pouring (for the immobilization layer) or spinning (for the control and flow layers). Following this, the layers were cured for one hour at 80°C, then bonded together thermally for 36 hours.

Large animals, including the embryos and larva of zebrafish, can have dimensions on the order of a few millimeters. To create molds of these dimensions, channels are milled into a rigid substrate using a milling machine or laser cutter. For regions requiring rounded channels, including sections containing microfluidic valves, a ball mill with a round tip can be used. A semi-rigid plastic layer can be cast from this mold. Once cured and peeled from the rigid layer, this plastic layer can serve as a mold to create PDMS devices with channels having large dimensions. Flow, control, and immobilization layers can be created in this fashion.

With reference now to Fig. 7(a), a 100 μm -tall flow channel 30 contains multiple 15 μm -tall aspiration channels 32 that capture/align the animals in a linear position when the pressure in the aspiration channels 32 is lowered. This aspiration immobilizes animals only partially, and it is not sufficient to completely restrict their motion. In order to fully immobilize the animals, a seal is created around them that restricts their motion completely. This sealing is done by using a 15-25 μm -thick flexible sealing membrane 34 that separates a press down channel 36 from the flow channel 30 underneath. The press down channel 36 can be rapidly pressurized to expand the thin membrane 34 downwards, as in the microfluidic valves discussed above. The membrane 34 flexes on top of the captured animals, wrapping around them and forming a tight seal which completely restrains their motion, holding them in a linear orientation. Although the animals are constrained by the PDMS membrane 34 from the top and bottom, they still have access to liquid media by way of the multiple aspiration channels 32 on the left side. Fig. 7(b) shows an image

of an immobilized adult animal in the device and Fig. 1(c) shows superimposed brightfield and fluorescent images taken at high magnification.

As discussed above, zebrafish have been recognized as a suitable model for drug screening and discovery. Zebrafish is a vertebrate animal model in which high-throughput studies can be performed due to its small size and optical transparency. Comparison of the human and zebrafish genomes suggests that a majority of human neurological disease genes and pathways also exist in zebrafish. Zebrafish models of human cardiovascular, endocrine, and brain disorders have been recently demonstrated. This animal is widely recognized as a powerful vertebrate model for dissecting the processes of neural development, neural regeneration, neural transmission and chemical toxicity. The genetic pathways involved in neural development, function and signaling pathways are highly conserved between zebrafish and humans. The use of zebrafish therefore permits otherwise impossible genetic manipulation and screening techniques in a vertebrate model. Figs. 8(a) and (b) illustrate an embodiment of the invention particularly adapted for immobilizing zebrafish in a well-defined orientation for cellular-resolution studies. Fig. 8(a) illustrates the microfluidic chip layout. The chip includes a bottom flow layer where animals are routed and a control layer that turns on and off the flow in the bottom flow layer utilizing membrane valves. In a first stage, animals are loaded into the chip and in stage 2, a single zebrafish is captured by a micro-aspirator 2 while the rest of animals in the channel are removed/recycled by flushing the channel. In the next stage 3, the yoke of an animal is pushed against a wide but shallow channel by aspiration while the freely moving tail of the animal aligns toward the aspiration port. The animal is immobilized as shown in Fig. 8(b). Thereafter, in a stage 4, the animal is released and sent to multi-well plates for incubation. As shown in Fig. 8(b) after the animal is aligned in stage 3 as shown in Fig. 8(a), flexible PDMS membranes on top of the animal are pressurized to immobilize the animal completely. The transparent animals can then be imaged and injured at cellular resolution through a glass cover slide or polymer layer bonded to the bottom of the chip. This immobilizer can also allow micro-injection into both larvae and embryos. A pulled quartz pipette can be inserted through a molded hole in the flexible membrane on the side of the immobilizer chip. The pipette can be

bonded/sealed to the membrane if desired. The flexing of the membrane permits limited motion of the pipette inside the chip.

Behavioral studies in small animals, including both zebrafish and *C. elegans*, are important for insight into a wide variety of biological processes. The high-throughput fluidic devices described above can enable many advanced behavioral studies to be performed on-chip. Behavioral responses to light, exposure to chemicals, electric shock, and mechanical stimulation can all be studied with little to no modifications to the devices discussed. Another method to study some of these responses, including response to electric shock and fluidic/air pressure, is to create a small element that can be inserted into an individual well of a multi-well plate. This is especially well suited for studies involving larger animals whose dimensions are on the order of individual wells.

References:

1. Kamath, R. S., Fraser, A. G., Dong, Y., Poulin, G., Durbin., R., Gotta, M., Kanapin, A., Le Bot, N., Moreno, S., Sohrmann, M., Welchman, D. P., Zipperlen, P. & Ahringer, J. (2003) *Nature* **421**, 231-7.
2. Simmer, F., Moorman, C., van der Linden, A. M., Kujik, E., van den Berghe, P.V., Kamath, R. S., Fraser, A. G., Ahringer, J., & Plasterk, R. H. (2003). *PLoS Biol* **1**, E12.
3. Sieburth, D., Ch'ng, Q., Dybbs, M., Tavazoie, M., Kennedy, S. Wang, D., Dupuy, D., Rual, J.F., Hill, D. E., Vidal, M., Ruvkun, G., and Kaplan, J. M. (2005). *Nature* **436**, 510-517.
4. Kaletta T., Butler L., Bogaert T. (2003) *Model Organisms in Drug Discovery* (John Wiley & Sons Ltd., West Sussex, UK).
5. Kaletta, T., & Hengartner, M. O. (2006) *Nat Rev Drug Discov* **5**, 387-398.
6. Segalat, L. (2007) *ACS Chem Biol.* **2**, 231-236.
7. Gray, J. M., Karow, D. S., Lu, H., Chang, A. J., Chang, J. S., Ellis, R. E. Marletta, M. A. & Bargmann, C. I. (2004) *Nature* **430**, 317-322.
8. Lange, D., Storment, C., Conley, C. & Kovacs, G. (2005) *Sensor Actuator B Chem*, **107**, 904-914.
9. Heng, X, Erickson, D., Baugh, L. R., Yaqoob, Z., Sternberg, P. W., Psaltis, D. & Yang, C. (2006) *Lab Chip*, **6**, 1274-1276.
10. Qin, J. & Wheeler, A. R. (2007) *Lab Chip*, **7**, 186-192.
11. Duffy, D. C., McDonald, J. C., Schueller, O. J. A. & Whitesides, G. (1998) *Analytical Chemistry* **70**, 4974-4984.
12. Unger, M. A., Chou, H-P., Thorsen, T., Scherer, A. & Quake, S. (2000) *Science* **288**, 113-116.
13. Dupuy D. *et al.* (2007) *Nature Biotechnology* **25**, 663-668.
14. Melin, J. & Quake, S. (2007) *Annu. Rev. Biophys. Biomol. Struct.* **36**, 213-231.
15. Zhang, J. H., Chung, T. D. & Oldenburg, K. R. (1999) *J. Biomol Screen.* **4**, 67-73.
16. Yanik, M. F., Cinar, H., Cinar, H. N., Chisholm, A., Jin, Y. & Ben-Yakar, A. (2004) *Nature* **432**, 822.

17. Yanik, M. F., Cinar, H., Cinar, H. N., Chisholm, A., Jin, Y. & Ben-Yakar, A. (2006)
IEEE Journal of Quantum Electronics **12**, 1283-1291.
18. Rohde, C. *et al.* (2007) *PNAS*, Vol. 104, No. 35, 13891-13895.
19. Zeng, F. *et al.* (2008) *Lab Chip*, **8**, 653-656.

It is recognized that modifications and variations of the invention disclosed herein will be apparent to those of ordinary skill in the art. It is intended that all such modifications and variations be included within the scope of the appended claims.

What is claimed is:

1. High throughput, whole-animal screening system comprising:
 - microfluidic staging device to concentrate animals;
 - microfluidic sorter adapted to isolate and/or immobilize a single animal;
 - a multiplexed micro-chamber chip for receiving an animal from the sorter, the chip including individually addressable screening chambers for immobilizing animals; and
 - an interface chip for loading material from an external source into microfluidic devices.
2. The system of claim 1 wherein the external source is a multi-well plate.
3. The system of claim 1 wherein chambers of the micro-chamber chip are adapted to receive individual animals.
4. The system of claim 1 wherein the components of the system are adapted for incubating the animals.
5. The system of claim 1 wherein the components of the system are adapted for monitoring the animals.
6. The system of claim 1 wherein the screening chambers are adapted for exposure of the animals to compounds.
7. The system of claim 6 wherein the selected compound is a biological compound.
8. The system of claim 7 wherein the selected compound is siRNAi.
9. The system of claim 7 wherein the selected compound is shRNA.
10. The system of claim 7 wherein the compound is a morpholino oligonucleotide.
11. The system of claim 6 wherein the selected compound is a chemical compound.

12. The system of claim 11 wherein the selected chemical compound is a synthetic compound.
13. The system of claim 11 wherein the selected chemical compound is a neurotoxin.
14. The system of claim 1 wherein the screening chambers are adapted for exposure of the animals to bacteria.
15. The system of claim 14 wherein the bacteria contains an RNAi vector.
16. The system of claim 1 wherein the screening chambers are adapted to expose the animals to virus.
17. The system of claim 16 wherein the virus contains an RNAi vector.
18. The system of claim 1 wherein the screening chambers are adapted for exposure of the animals to nanoparticles.
19. The system of claim 1 wherein the material comprises chemical compounds.
20. The system of claim 1 wherein the material comprises proteins.
21. The system of claim 1 wherein the material comprises cells.
22. The system of claim 1 wherein the material comprises animals.
23. The system of claim 1 wherein the staging device comprises:
fluidic means for introducing multiple animals;
fluidic means for removing excess liquid from animals; and
valves for controlling fluid flow to and from the staging device.
24. The system of claim 23 wherein the straining apparatus comprises a plurality of small posts, allowing liquid to pass while preventing the animals from passing.
25. The system of claim 23 wherein the straining apparatus comprises a section of the device with a smaller dimension than the animals, allowing liquid to pass while preventing the animals from passing.

26. The system of claim 23 wherein the animals are introduced to the device via a pressurized reservoir.
27. The system of claim 23 wherein the animals are introduced to the device from an external source.
28. The system of claim 23 wherein the animals are introduced via aspiration
29. The system of claim 27 wherein the external source is a multi-well plate.
30. The system of claim 28 wherein the aspiration line is positioned manually.
31. The system of claim 28 wherein the aspiration line is positioned using an electronically controlled positioning device.
32. The system of claim 23 wherein the animals are output to another microfluidic device.
33. The system of claim 23 wherein the animals are output to an external collection location.
34. The system of claim 33 wherein the collection location is a multi-well plate.
35. The system of claim 1 wherein the sorter comprises:

fluidic means for introducing animals to the sorter; and

Mechanical means for immobilizing the animal.
36. The system of claim 35 wherein the animals are introduced to the device via a pressurized reservoir.
37. The system of claim 35 wherein the animals are introduced to the device via aspiration from an external source.
38. The system of claim 37 wherein the external source is a multi-well plate.
39. The system of claim 35 wherein the animals are introduced to the device via capillary action.

40. The system of claim 35 wherein the immobilization is provided via suction means.
41. The system of claim 35 further including means for pressing on the animal.
42. The system of claim 41 wherein the means for pressing on the animal include a microfluidic valve.
43. The system of claim 42 wherein the microfluidic valve consists of a flexible membrane that can be pressurized to expand into the channel containing the animal.
44. The system of claim 42 wherein the microfluidic valve consists of a normally closed flexible membrane that can be opened using a low pressure.
45. The system of claim 41 wherein the region in which the immobilization occurs has a rounded profile.
46. The system of claim 35 including means for pressing on the animal for immobilization.
47. The system of claim 46 wherein the means for pressing on the animal include a microfluidic valve.
48. The system of claim 47 wherein the microfluidic valve consists of a flexible membrane that can be pressurized to expand into the channel containing the animal.
49. The system of claim 47 wherein the microfluidic valve consists of a normally closed flexible membrane that can be opened using a low pressure.
50. The system of claim 46 wherein the region in which the immobilization occurs has a rounded profile.
51. The system of claim 35 adapted for microinjection.
52. The system of claim 51 wherein the injected material is a chemical compound.
53. The system of claim 51 wherein the injected material is a virus.

54. The system of claim 51 wherein the injected material is cDNA.
55. The system of claim 51 wherein the injected material is mRNA.
56. The system of claim 51 wherein the injected material is a RNA interference oligonucleotide.
57. The system of claim 51 wherein the injected material is bacteria.
58. The system of claim 51 wherein the injected material is a fluorescent dye.
59. The system of claim 51 wherein the injected material is a morpholino oligonucleotide.
60. The system of claim 35 adapted for high-resolution imaging.
61. The system of claim 35 adapted for light surgery.
62. The system of claim 35 adapted for photo activation.
63. The system of claim 35 adapted for electroporation.
64. The system of claim 35 wherein the animals are output to an external collection location.
65. The system of claim 64 wherein the collection location is a multi-well plate.
66. The system of claim 35 further including means to orient the animals using fluidic pressure.
67. The system of claim 1 wherein the micro-chamber chip includes a plurality of chambers that include means to capture an animal.
68. The system of claim 67 wherein the means for capturing an animal comprises a plurality of small posts, allowing liquid to pass while preventing the animals from passing.
69. The system of claim 68 wherein the posts are arranged in a curved configuration.
70. The system of claim 67 wherein the means for capturing an animal comprises a section of the device with a smaller dimension than the animals, allowing liquid to pass while preventing the animals from passing.

71. The system of claim 67 adapted for high-resolution imaging.
72. The system of claim 67 adapted for microinjection.
73. The system of claim 72 wherein the injected material is a chemical compound.
74. The system of claim 72 wherein the injected material is a virus.
75. The system of claim 72 wherein the injected material is cDNA.
76. The system of claim 72 wherein the injected material is mRNA.
77. The system of claim 72 wherein the injected material is a RNA interference oligonucleotide.
78. The system of claim 72 wherein the injected material is bacteria.
79. The system of claim 72 wherein the injected material is a fluorescent dye.
80. The system of claim 72 wherein the injected material is morpholino oligonucleotides.
81. The system of claim 67 adapted for light surgery.
82. The system of claim 67 adapted for photo activation.
83. The system of claim 67 adapted for electroporation.
84. The system of claim 67 further including means for pressing onto the animal to immobilize it.
85. The system of claim 67 wherein the means for pressing on the animal includes a microfluidic valve.
86. The system of claim 85 wherein the microfluidic valve consists of a flexible membrane that can be pressurized to expand into the channel containing the animal.
87. The system of claim 85 wherein the microfluidic valve consists of a normally closed flexible membrane that can be opened using a low pressure.

88. The system of claim 67 further including means to orient the animals using fluidic pressure.
89. The system of claim 1 wherein the interface chip resides above the well-plate, the interface chip including a separate aspiration tip placed within each individual well of the well-plate.
90. The system of claim 89 further including a multiplexing microfluidic circuit providing a path between an individual well of the well-plate and another part of the system thereby enabling delivery of a plurality of compounds using only a single connection.
91. The system of claim 1 wherein the components of the system are made of polymer bonded to a transparent substrate.
92. The system of claim 1 further including a plurality of valves.
93. The system of claim 92 wherein the valves are made from flexible membrane to block or allow flow through fluidic channels.
94. The system of claim 93 wherein the valves are in a normally open state.
95. The system of claim 93 wherein the valves are in a normally closed state.
96. The system of claim 1 wherein the system is incorporated with an imaging structure.
97. The system of claim 96 wherein the imaging structure includes white-light microscopy.
98. The system of claim 96 wherein the imaging structure includes interference microscopy.
99. The system of claim 96 wherein the imaging structure includes fluorescence microscopy.
100. The system of claim 96 wherein the imaging structure includes confocal microscopy.
101. The system of claim 96 wherein the imaging structure includes two-photon microscopy.
102. The system of claim 96 wherein the imaging structure has laser-microsurgery capability.
103. The system of claim 1 wherein the animal is genetically modified to express RNA.

104. The system of claim 1 wherein the animal is genetically modified to express a specific protein.
105. The system of claim 104 wherein the protein is fluorescent.
106. The system of claim 104 wherein the protein is photo-sensitive.
107. The system of claim 106 wherein the photo-sensitive protein is an ion channel.
108. The system of claim 104 wherein the animal is genetically mutated.
109. The system of claim 1 wherein the animal can survive in liquid media.
110. The system of claim 1 wherein the animal is a nematode.
111. The system of claim 110 wherein the nematode is *C. elegans*.
112. The system of claim 1 wherein the animal is a vertebrate.
113. The system of claim 112 wherein the vertebrate is zebrafish.
114. The system of claim 1 used for mutagenesis screens.
115. The system of claim 1 used for drug screens.
116. The system of claim 1 used for viral screens.
117. The system of claim 1 used for bacterial screens.
118. The system of claim 1 used for studying toxicity.
119. The system of claim 1 used for studying neural degeneration.
120. The system of claim 1 used for studying neural regeneration.
121. The system of claim 1 used for studying traumatic brain injury.
122. The system of claim 121 wherein the injury is generated using a pressure wave.

123. The system of 122 wherein the pressure wave is generated using a piezo-electric element.
124. The system of claim 1 used for studying blunt trauma
125. The system of claim 124 wherein the injury is induced using a pressure wave
126. The system of claim 125 wherein the pressure wave is generated using a piezo-electric element.
127. The system of claim 124 wherein the injury is induced using a blunt ended tip.
128. The system of claim 127 wherein the tip is moved with a solenoid.
129. The system of claim 1 used for studying neurological disorders.
130. The system of claim 1 used for studying Alzheimer's disease.
131. The system of claim 1 used for studying Parkinson's disease.
132. The system of claim 1 used for studying amyotrophic lateral sclerosis
133. The system of claim 1 used for studying wound healing.
134. The system of claim 1 used for studying the immune system.
135. The system of claim 1 used for studying metabolism.
136. The system of claim 1 used for studying aging.
137. The system of claim 1 used for studying development.
138. The system of claim 1 used for studying stem cells.
139. The system of claim 1 used for studying reproduction.
140. The system of claim 1 used for studying the heart.
141. The system of claim 1 used for studying heart disease.

142. The system of claim 1 used for studying bone.
143. The system of claim 1 used for studying cancer.
144. The system of claim 1 used for studying skin.
145. The system of claim 1 used for studying vascular development.
146. The system of claim 1 used for studying vasculature
147. The system of claim 1 used for studying the liver.
148. The system of claim 1 used for studying the kidney.
149. The system of claim 1 used for studying the bladder.
150. The system of claim 1 used for studying the intestinal tract.
151. The system of claim 1 used for studying the tooth.
152. The system of claim 1 used for studying muscle.
153. The system of claim 1 wherein the system is used for microsurgery.
154. The system of claim 153 wherein the microsurgery is performed with a laser.
155. The system of claim 154 wherein the laser is a femtosecond laser.
156. The system of claim 1 used for behavioral studies.
157. The system of claim 156 where the animal's behavioral response to light stimulation is studied.
158. The system of claim 156 where the animal's behavioral response to controlled fluidic flow or fluidic pressure is studied.
159. The system of claim 156 where the animal's behavioral response to an image projected into the eyes of the animal is studied.

160. The system of claim 156 where the animal's behavioral response to images projected into the eyes of the animal is studied.
161. The system of claim 156 where the animal's behavioral response to electric shock is studied.
162. The system of claim 156 where the animal's behavioral response to mechanical stimulation is studied.
163. The system of claim 156 where the animal's behavioral response to chemical compounds is studied.
164. The system of claim 156 where the animal's behavioral response to biological compounds is studied.
165. Microfluidic device comprising:
- fluidic means for introducing animals to the sorter; and
 - Mechanical means for immobilizing the animal.
166. Chamber chip comprising:
- an inlet for fluid entraining an animal
 - an inlet for fluid entraining compounds;
 - a plurality of micro-chambers that include a means to capture animals; and
 - a fluid outlet.
167. Staging chip comprising:
- fluidic means for introducing multiple animals;
 - fluidic means for removing excess liquid from animals; and
 - valves for controlling fluid flow to and from the staging device

168. Interface chip for use in conjunction with a multi-well plate comprising:
- structure including a plurality of aspiration tips extending from the structure into individual wells of the multi-well plate; and
 - multiplexing microfluidic circuitry providing a path between an individual well of the well-plate and a single outlet of the interface chip.
169. The system of claim 168 wherein the structure resides above the multi-well plate
170. High-throughput, whole-animal screening system comprising;
- a microfluidic sorter adapted to isolate and/or immobilize a single animal; and
 - a multiplexed micro-chamber chip for receiving animals from the sorter, the chip including individually addressable screening chambers for immobilizing animals.
171. High-throughput, whole-animal screening system comprising;
- a microfluidic staging chip;
 - a microfluidic sorter adapted to isolate and/or immobilize a single animal; and
 - a multiplexed micro-chamber chip for receiving animals from the sorter, the chip including individually addressable screening chambers for receiving and/or immobilizing one or more animals.
172. High-throughput, whole-animal screening system comprising:
- a multiplexed micro-chamber chip for receiving animals from the sorter, the chip including individually addressable screening chambers for receiving and/or immobilizing one or more animals; and
 - an interface chip for loading material from one or more wells of a multi-well plate into one or more screening chambers.

173. High-throughput, whole-animal screening system comprising;
- a microfluidic sorter adapted to isolate and/or immobilize a single animal;
 - input reservoir
 - output reservoir
174. The system of claim 1 wherein the animal is a member of the genus *Drosophila*.
175. Method for behavioral studies of small animals comprising;
- Element capable of entering individual wells in a multi-well plate to provide stimuli for behavioral studies.
176. The system of claim 175 wherein the element contains electrodes for studying response to electric shock.
177. The system of claim 175 wherein the element contains an aperture for delivering pressurized air to the animal.
178. The system of claim 175 wherein the element contains an aperture for delivering pressurized liquid to the animal.
179. The system of claim 175 used to study an animal that can survive in liquid media.
180. The system of claim 175 wherein the animal is a nematode.
181. The system of claim 180 wherein the nematode is *C. elegans*.
182. The system of claim 175 wherein the animal is a vertebrate.
183. The system of claim 182 wherein the vertebrate is zebrafish.

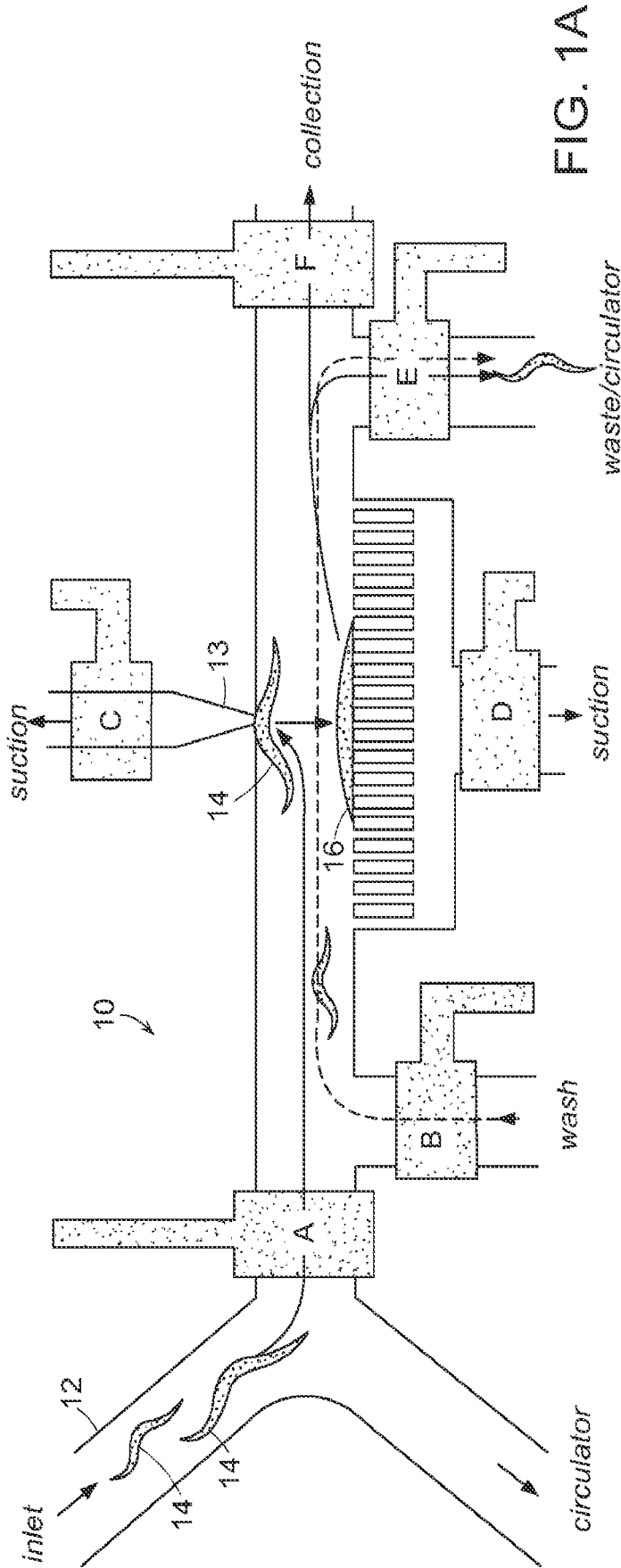

FIG. 1A

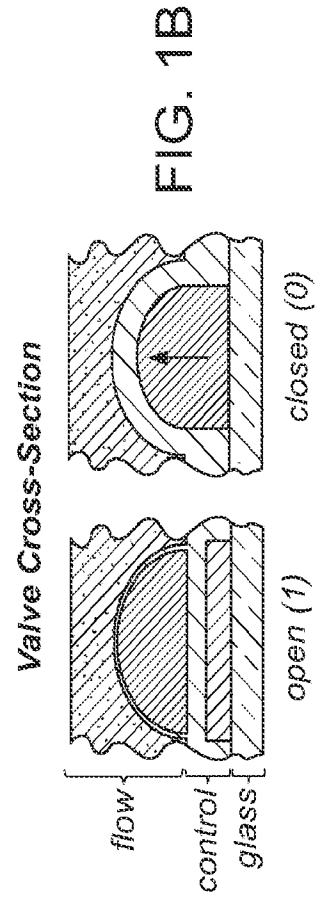

FIG. 1B

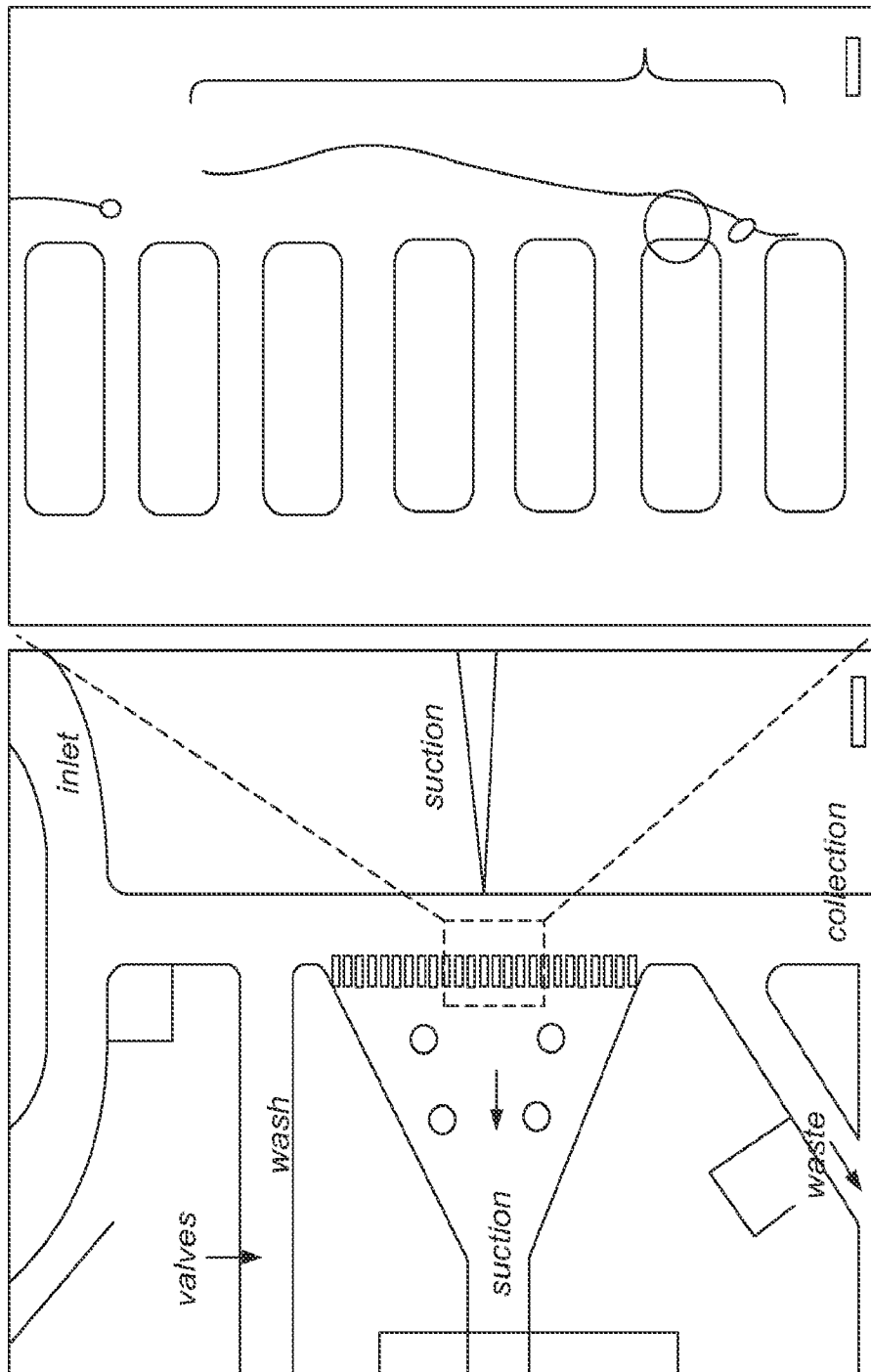

FIG. 2A

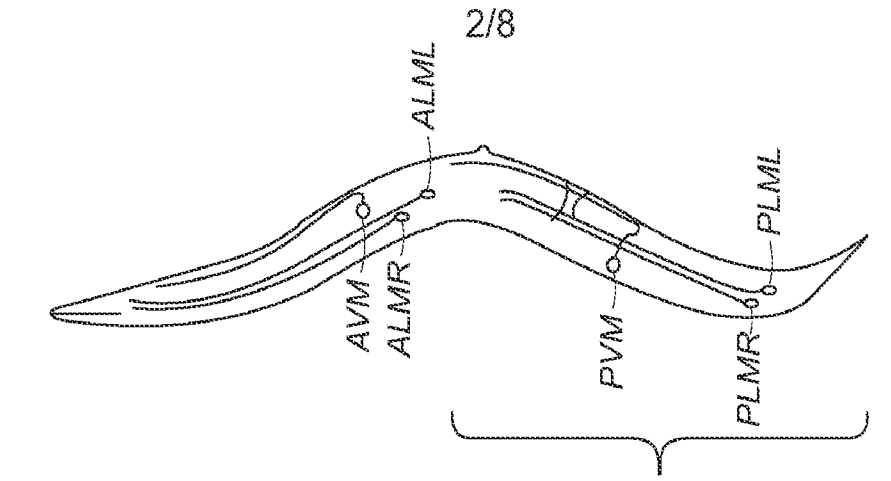

FIG. 2B

FIG. 2C

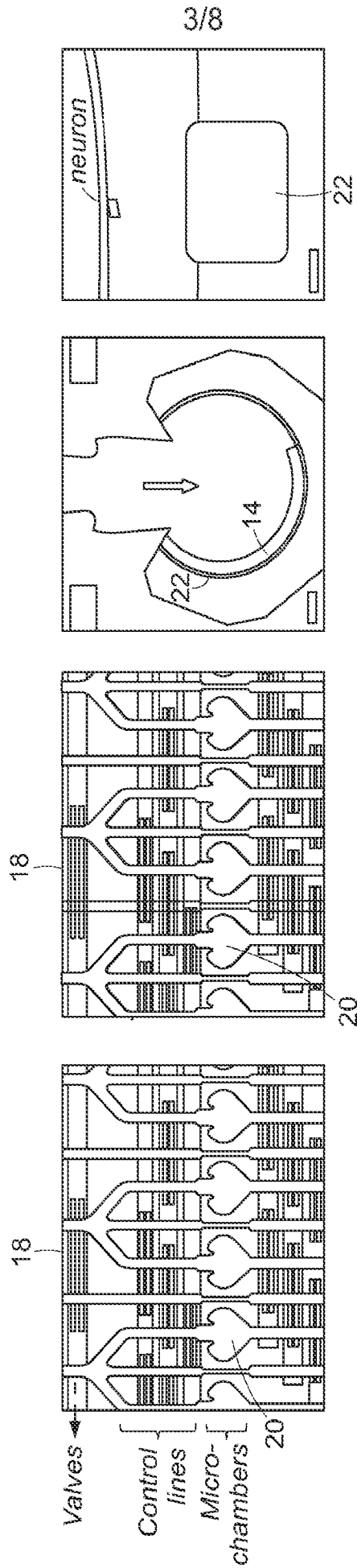

FIG. 3D

FIG. 3C

FIG. 3B

FIG. 3A

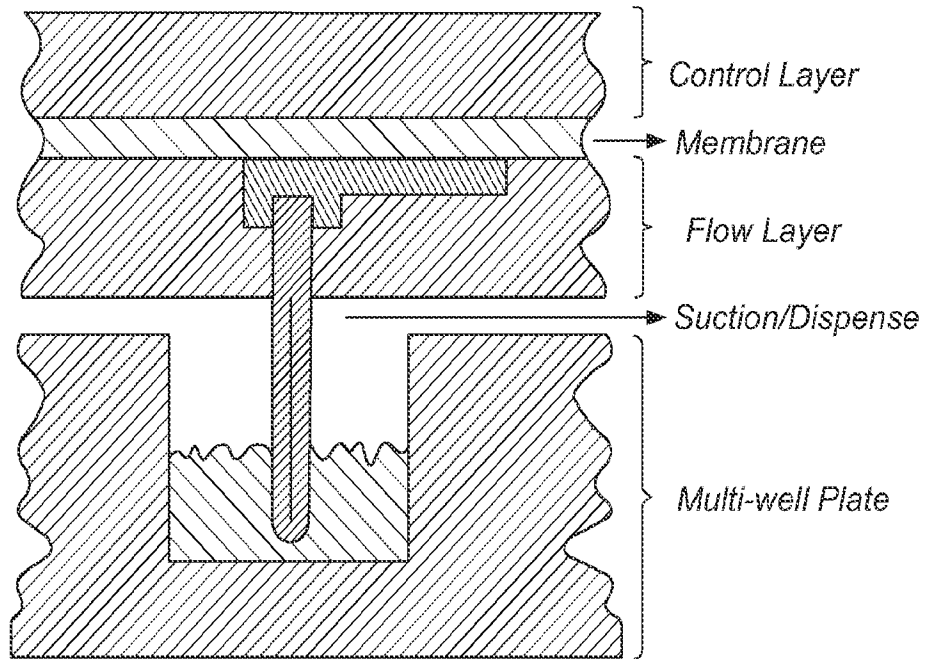

FIG. 4A

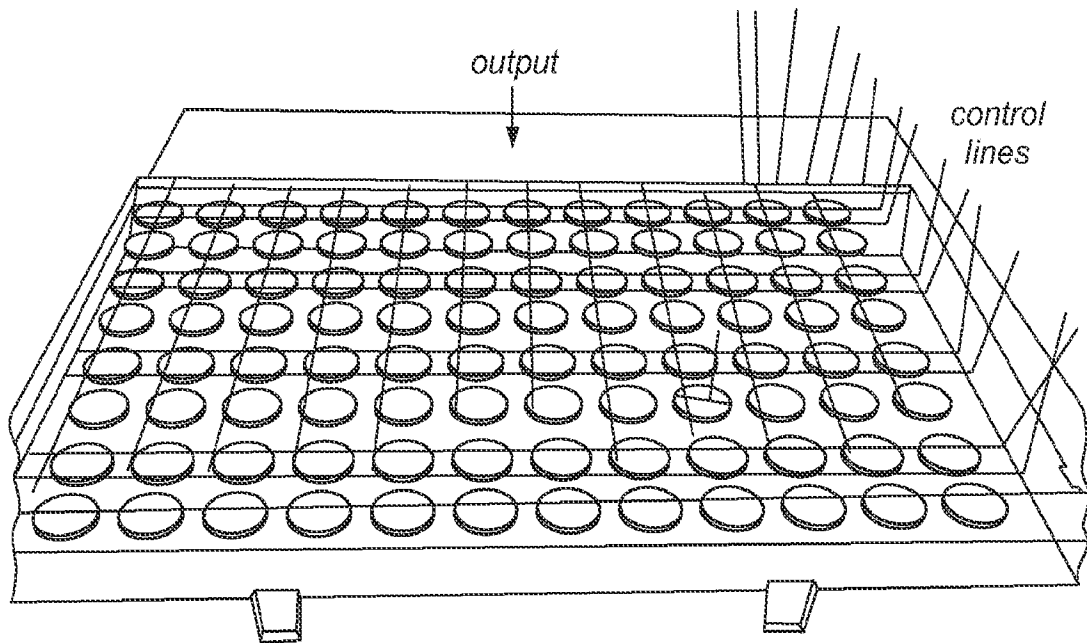

FIG. 4B

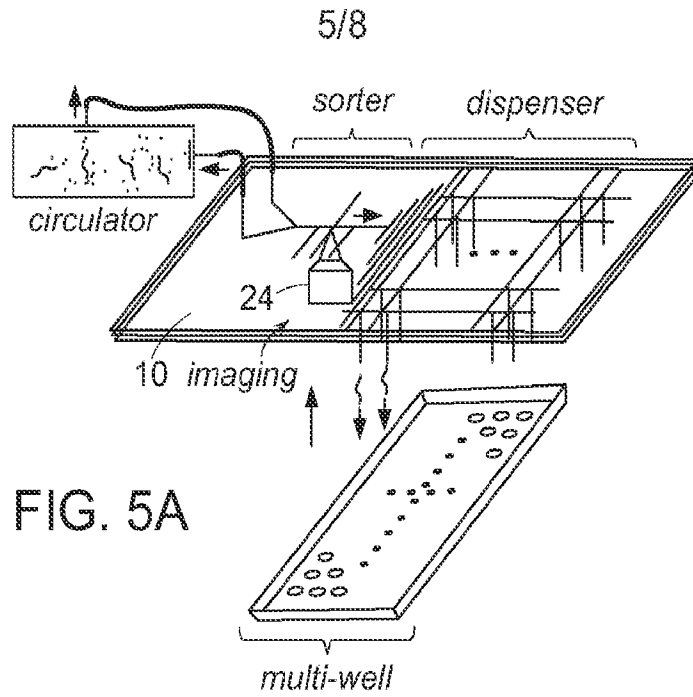

FIG. 5A

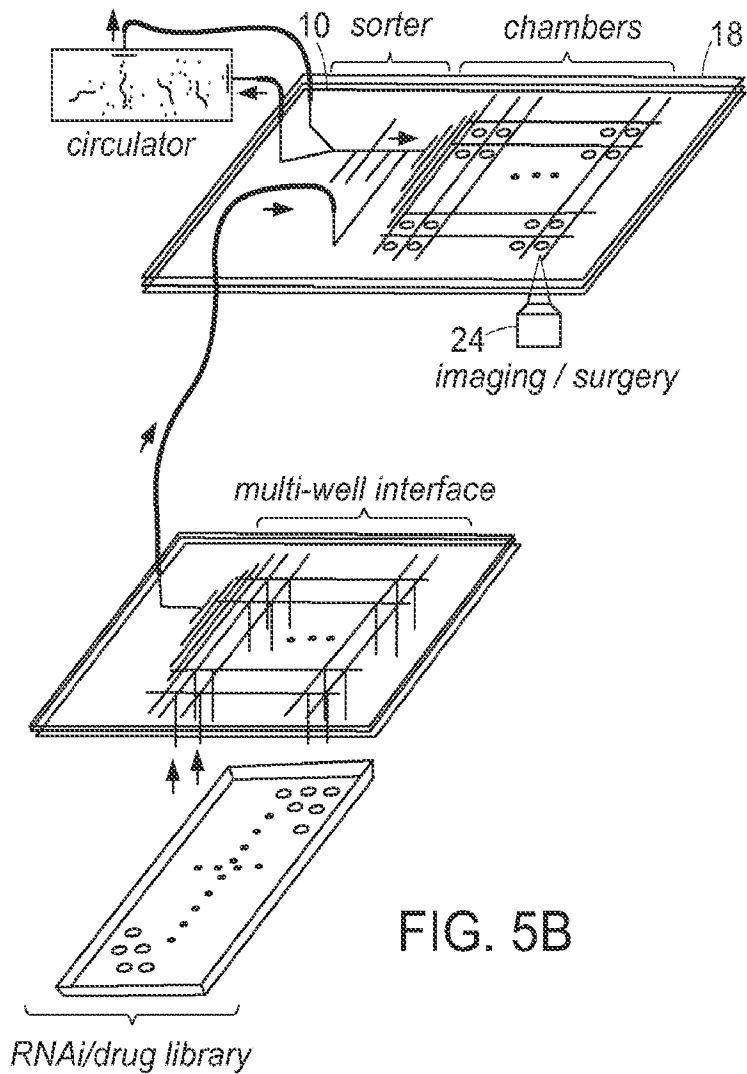

FIG. 5B

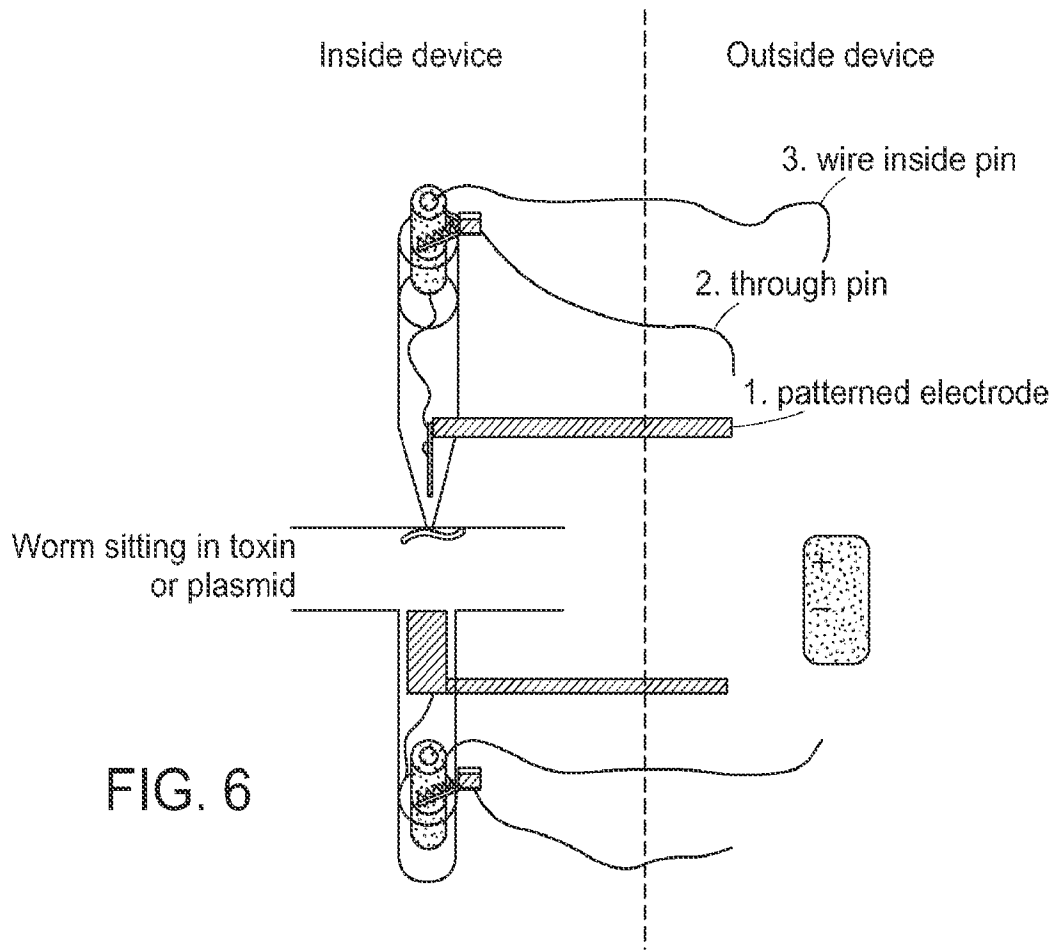

FIG. 6

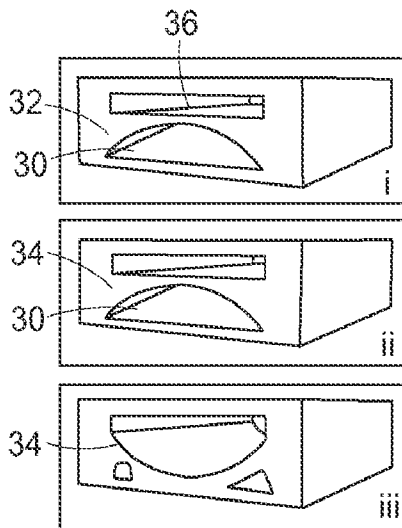

FIG. 7A

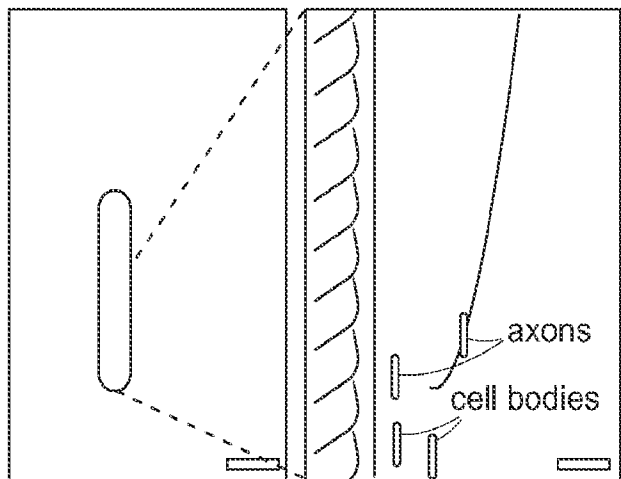

FIG. 7B

FIG. 7C

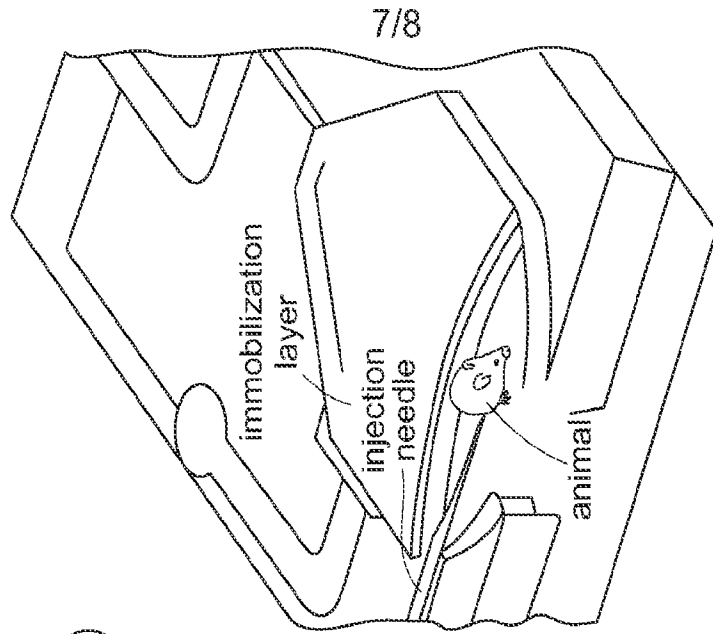
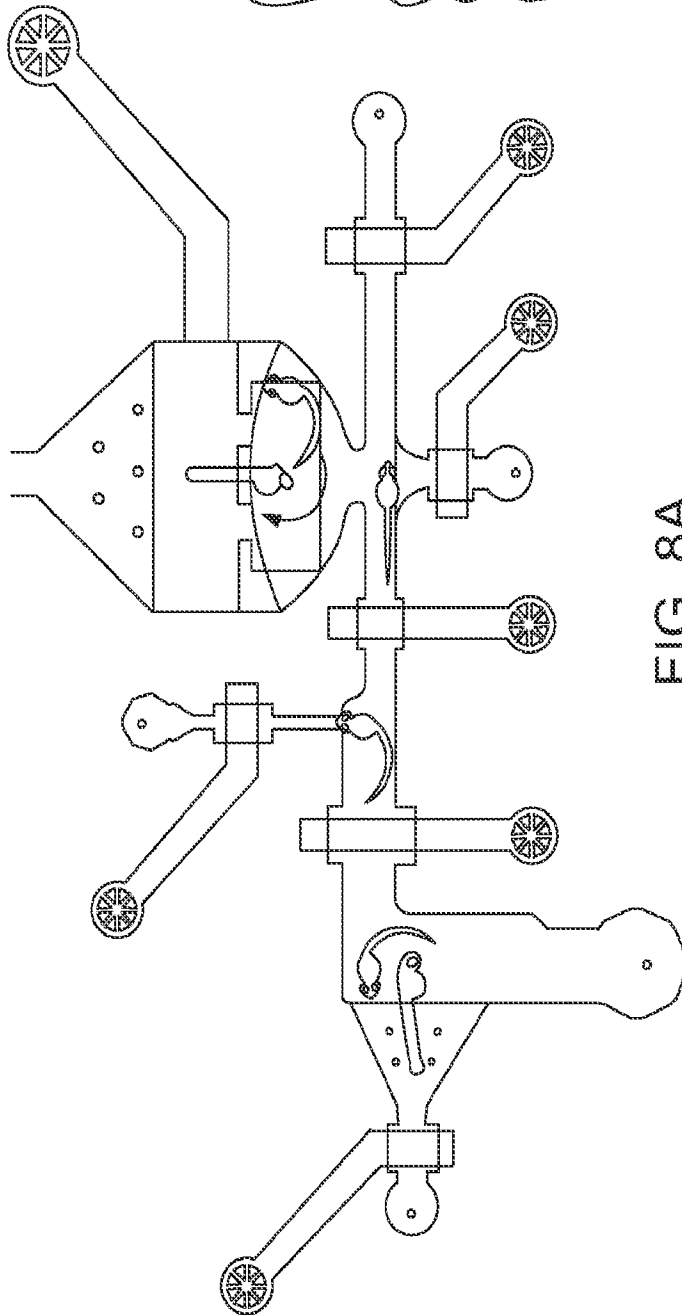

FIG. 8B



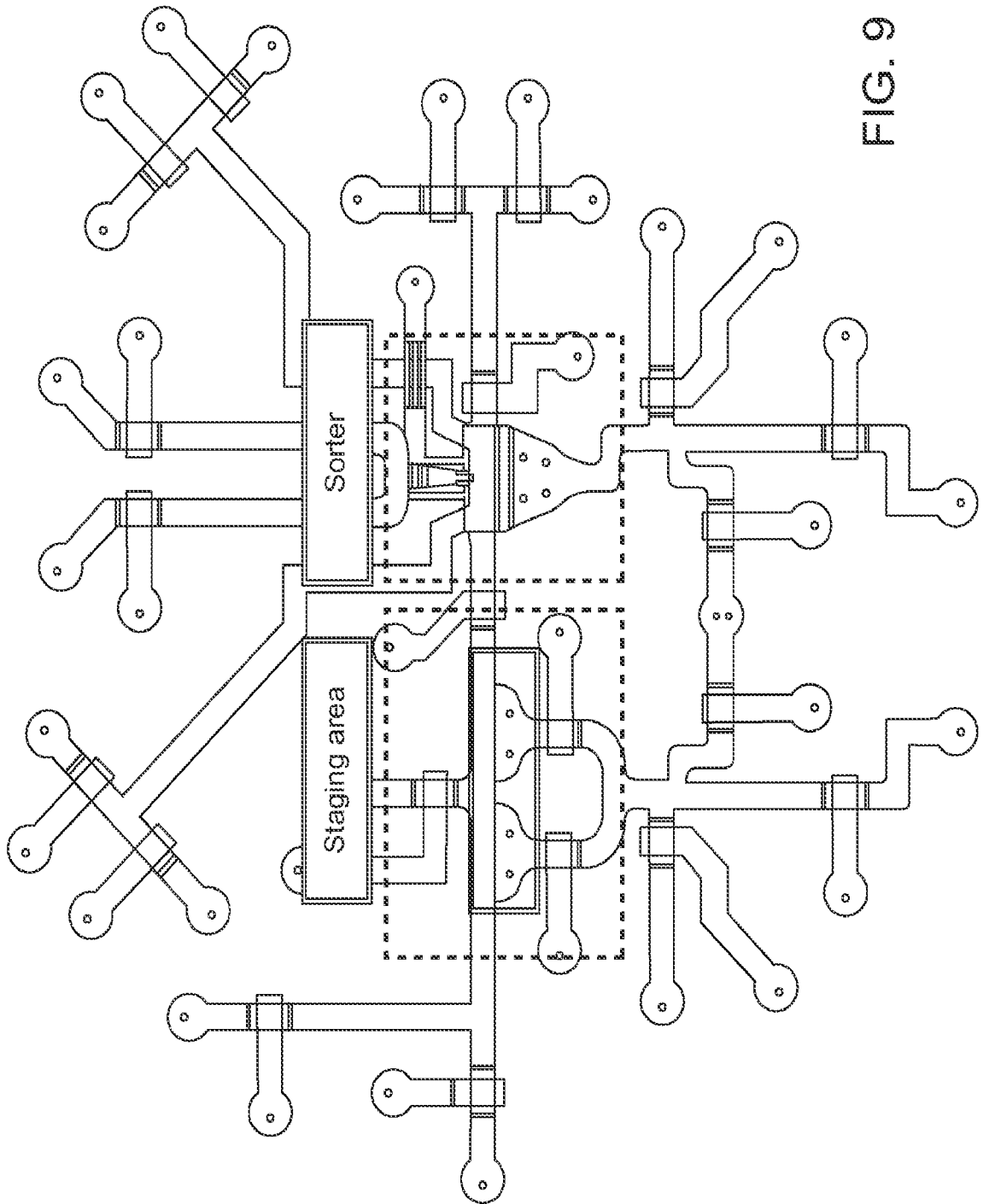

FIG. 9