

F. H. BROWN.

Sewing Machine Guide and Tuck Marker.

No. 51,547.

Patented Dec. 19, 1865.

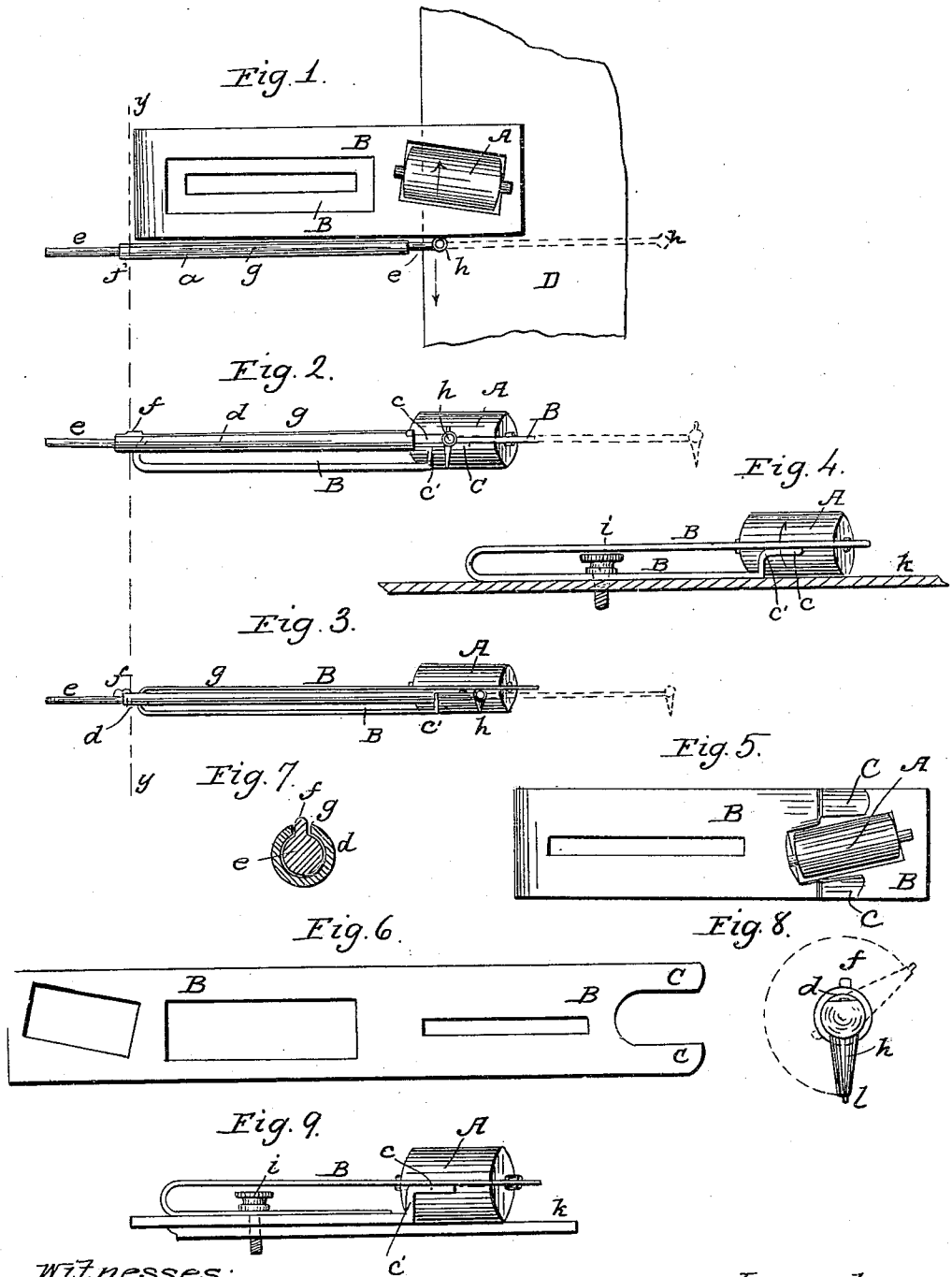

Witnesses:
J. A. Housington
C. L. Jenke

Inventor.
Franklin H. Brown

UNITED STATES PATENT OFFICE.

FRANKLIN H. BROWN, OF CHICAGO, ILLINOIS.

IMPROVEMENT IN GUIDE AND TUCK-MARKER FOR SEWING-MACHINES.

Specification forming part of Letters Patent No. 51,547, dated December 19, 1865.

To all whom it may concern:

Be it known that I, FRANKLIN H. BROWN, of Chicago, in the county of Cook and State of Illinois, have invented a new and Improved Guide and Tuck-Marker Combined for Sewing-Machines; and I do hereby declare that the following is a full and exact description thereof.

The nature of my invention consists in providing a sewing-machine guide with a roller set into and diagonally across the end in such a manner as to gently urge the cloth up to the guide as it is being moved forward toward the needle to be stitched, in combination with the guide-pieces hereinafter described; also, in providing a sewing-machine guide with an extension pencil-holder for the purpose of marking the tuck-fold.

To enable others skilled in the art to make and use my invention, I will describe its construction and operation, reference being had to the accompanying drawings, which form a part of this specification, in which—

Figure 1 is a top view of the guide and tuck-marker combined, with a piece of cloth, D, placed under the roller A in proper position for work. Fig. 2 is a side view of the guide and tuck-marker attached to the upper part of spring-plate B. Fig. 3 is a side view of the guide with tuck-marker attached at either end and below the top part of plate B. Fig. 4 is a side view of the guide, showing the manner of attaching it to the bed-plate of a sewing-machine by means of a thumb-screw, as usual. Fig. 5 is a bottom view of the guide without the tuck-marker. Fig. 6 is a top view of plate B before it is folded together. Fig. 7 is a cross-section of the tuck-marker or extension pencil-holder, taken at the red line *y y*. Fig. 8 is a front end view of the tuck-marker, with dotted lines indicating its position when turned back and not in use. Fig. 9 is a side view of a common sewing-machine guide with my improvements, excepting the tuck-marker.

I construct my guide from sheet-metal strips, as shown in Fig. 6, with openings cut through, as indicated. The large opening next to the diagonal one at the end should be made large enough to allow the thumb-screw to pass through and fasten through the long, narrow slot and into the bed-plate of a sewing-machine, as shown in Fig. 4. Strip B is bent about midway between the wide and narrow open-

ings and folded over until the openings come one above the other, and until both ends of plate B shall point in one direction and lie parallel, or nearly so, the whole distance back to the place of bending, with the exception of that part of plate B which is turned up in a vertical direction to form the common sewing-machine guide, which I have lettered in the drawings C'. The ends C C, which are bent forward from the top of the vertical guides C', lie close to the upper end of plate B, and are parallel with it. The reason why I thus bend points C C forward from the top of the guides C' is to prevent the cloth from turning up over the guides C', this being effectual and much cheaper than setting pins into the lower plate to project through the upper.

Roller A may be made of wood, metal, rubber, or of any other known suitable material.

I place roller A at an angle across and horizontally with and into the end of the spring-plate B. When the cloth is moved in direction of the arrow, it being between the roller and bed-plate K of the machine, the friction of the cloth upon the roller A causes the roller to revolve. The natural influence of the roller upon the cloth is to guide it forward in a line at right angles to its axle, which it will do until the cloth comes in contact with the vertical guides C', which prevents its further progress in that direction, but is kept to the guides as it moves in direction of the arrow, as shown on cloth D in Fig. 1. Another benefit is experienced by the use of roller A. It being smooth and pressing onto the cloth its whole length to the guide causes the tucks, plaits, and cloth to lie close and smooth and to move forward to the needle without mark or wrinkle. Thus the work of guiding and properly holding the goods to be sewed on a machine is done automatically without the assistance of the operator except when placing the goods at the beginning of each new line of stitching.

e d h is an extension pencil-holder, which may be attached to the upper part of plate B, Fig. 2; or it may be attached to the guides *c'* below the upper part of plate B, as shown in Fig. 3.

The extension pencil-holder is constructed of a sheath, *d*, made of thin metal, or any other suitable material, having a longitudinal slot, *g*, extending along its whole length, in-

errupted only at the forward end, as shown in Figs. 1, 2, and 3.

e is a wire fitting into the sheath *d*, and provided at the front end with pencil-holder *h*, which is a small tube fastened at right angles onto the end of wire *e*, for the purpose of containing a pencil or soft lead for marking on goods when there are two or more tucks to lay, a shirt-bosom to plait, or a line to be indicated for stitching.

The operator may draw pencil-holder *h* out in the direction of the dotted lines any suitable distance, and thus adjust it to mark the cloth for the next row of stitches. Holder *h* being down, the lead or marker will rest upon the cloth and leave a mark upon the cloth as it is drawn forward. Pencil-holder *h* is prevented from turning around, when the cloth is moving against it, by projection *f* upon wire *e*, resting in slot *g*. When marking is not required wire *e* should be pushed back until projection *f* is

moved out of slot *g*, when holder *h* may be turned out of the way, as shown in Fig. 8 by dotted lines.

What I claim as my invention, and desire to secure by Letters Patent, is—

1. Roller *A*, in combination with the vertical guide *c'* and horizontal pieces *c c*, when the roller is placed horizontally with and at an angle across and into said guide, as and for the purposes set forth.

2. The combination of the horizontal pieces *C C* and the vertical guide *C'*, as and for the purposes specified.

3. Sheath *d*, pencil-holder *h*, wire *e*, and projection *f*, in combination with a sewing-machine guide, substantially as set forth.

FRANKLIN H. BROWN.

Witnesses:

J. A. HOISINGTON,
C. L. JENKS.