

(19) World Intellectual Property Organization
International Bureau



(43) International Publication Date
26 May 2005 (26.05.2005)

PCT

(10) International Publication Number
WO 2005/047924 A1

- (51) International Patent Classification⁷: **G01S 5/00**, H04L 12/56
- (74) Agent: **LOVEN, Keith, James**; Loven & Co, Quantum House, 30 Tentercroft Street, Lincoln, Lincolnshire LN5 7DB (GB).
- (21) International Application Number: PCT/GB2004/050020
- (81) Designated States (unless otherwise indicated, for every kind of national protection available): AE, AG, AL, AM, AT, AU, AZ, BA, BB, BG, BR, BW, BY, BZ, CA, CH, CN, CO, CR, CU, CZ, DE, DK, DM, DZ, EC, EE, EG, ES, FI, GB, GD, GE, GH, GM, HR, HU, ID, IL, IN, IS, JP, KE, KG, KP, KR, KZ, LC, LK, LR, LS, LT, LU, LV, MA, MD, MG, MK, MN, MW, MX, MZ, NA, NI, NO, NZ, OM, PG, PH, PL, PT, RO, RU, SC, SD, SE, SG, SK, SL, SY, TJ, TM, TN, TR, TT, TZ, UA, UG, US, UZ, VC, VN, YU, ZA, ZM, ZW.
- (22) International Filing Date: 25 October 2004 (25.10.2004)
- (25) Filing Language: English
- (26) Publication Language: English
- (30) Priority Data: 0326050.2 7 November 2003 (07.11.2003) GB
- (71) Applicant (for all designated States except US): **EXCUSE ME INVESTMENTS LTD**; Drake Chambers, P O Box 3321, Road Town, Tortola (VG).
- (84) Designated States (unless otherwise indicated, for every kind of regional protection available): ARIPO (BW, GH, GM, KE, LS, MW, MZ, NA, SD, SL, SZ, TZ, UG, ZM, ZW), Eurasian (AM, AZ, BY, KG, KZ, MD, RU, TJ, TM), European (AT, BE, BG, CH, CY, CZ, DE, DK, EE, ES, FI, FR, GB, GR, HU, IE, IT, LU, MC, NL, PL, PT, RO, SE, SI, SK, TR), OAPI (BF, BJ, CF, CG, CI, CM, GA, GN, GQ, GW, ML, MR, NE, SN, TD, TG).
- (72) Inventor; and
- (75) Inventor/Applicant (for US only): **CROOKS, Henrietta, Sara** [GB/GB]; The Gatehouse, School Lane, Colston Bassett, Nottingham, Nottinghamshire NG12 3FD (GB).

[Continued on next page]

(54) Title: POSITION LOCATING SYSTEM

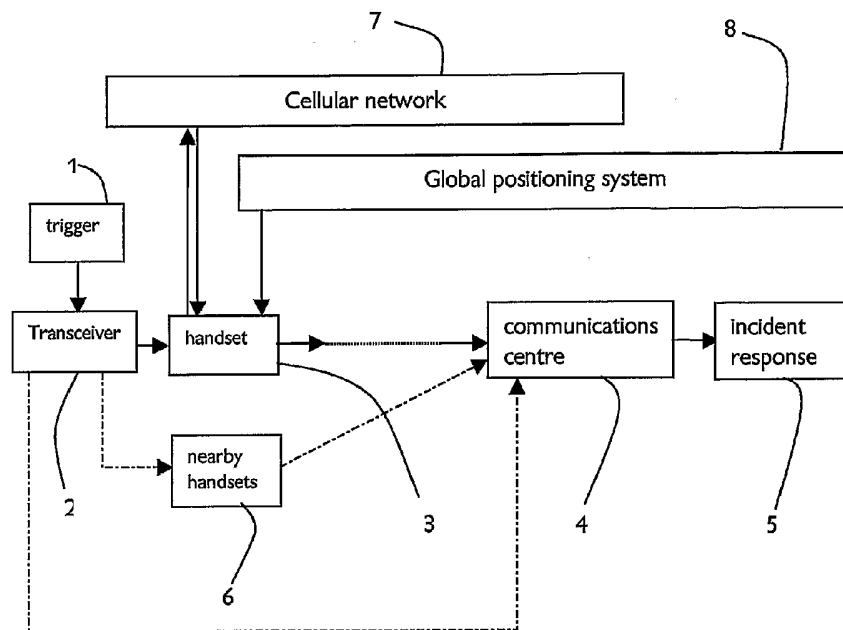

(57) Abstract: A position locating system comprises a radio receiving base station (22) and a plurality of portable radio transmitter/receiver devices (21) each having means (25) for determining an instantaneous global position for said device and adapted to signal said position to the base station, each device also being adapted to monitor transmissions from other devices within the system and to relay said messages from one device to another, whereby a message from a device out of range of the base station can be relayed to the base station.

WO 2005/047924 A1



Published:

— *with international search report*

For two-letter codes and other abbreviations, refer to the "Guidance Notes on Codes and Abbreviations" appearing at the beginning of each regular issue of the PCT Gazette.

POSITION LOCATING SYSTEM

Field of the Invention

The present invention is concerned with systems and methods for tracking persons and/or assets. The invention is more particularly concerned with ensuring the safety
5 of persons by providing a system enabling more accurate location than hitherto possible.

Background to the Invention

There is an increasing awareness that the protection and safety of people and their belongings is becoming more of a problem than it was until recently. For example, theft
10 of personal possessions, hi-tech portable equipment etc has become more endemic and perpetrators have become more audacious. There has also been an alarming increase in the numbers of abductions and kidnappings of people. This is even more disturbing when children are the targets. Of course, there are instances where children simply lose their bearing and become separated from their parents or guardians.

Tracking systems are known, which rely on Global Positioning Systems (GPS), triangulation via radio beacons, and cellular telephone auto-location. In the example using
15 cellular telephony, there is clearly a problem in areas of poor coverage. In addition, a user will be confined to a particular network to which he/she subscribes so, even if there is good or acceptable coverage for one network, the same may not be true of another network. This could leave the subscriber vulnerable if he happens to subscribe to the
20 network with the poorest coverage in the particular area in which he finds himself requiring a location service.

In addition, cellular auto-location systems have limited accuracy. This is not unsurprising since cellular systems never were intended for location purposes. The only reason
25 that the system "needs" to know the subscriber's location is to ensure that service is provided within a cell and when the subscriber moves from one cell to another.

Present-day cellular systems have many enhanced services, one of which provides information to a subscriber based on his location. This can be of advantage to a subscriber in a strange (to him) location, looking for accommodation, food, general information about the location and so on. The network clearly needs to know the whereabouts
30 of the subscriber to make relevant information available via the handset. Cellular systems

can determine positional accuracy to within 100 metres but often to within 400 metres. This is tantamount to indicating in what street a handset may be located but this would not necessarily be accurate enough to locate a missing person or stolen asset(s). What is needed is the ability to locate a building within a street or even a room within a building.

5 Global Positioning Systems GPS have become a standard for position location and navigation, especially in road vehicles and other forms of transport. Assisted-GPS provides an enhanced service and positional accuracy but remains subject to various perturbations that deny its full potential. Some such factors include the configuration of the transmitter and receiver, physical location (e.g. geographic latitude; surrounding objects
10 blocking reception or causing multi-path reception) satellite constellation status and ionospheric conditions. GPS tends to be unreliable, at best, within buildings, and may well be unavailable.

Despite these technical advances, there still remains a need for a more dependable and accurate system for position location that requires little effort on the part of the subscriber but which provides an accurate indication of his/her location, especially in emergency or comparable circumstances.

It is especially important to be able to continue to monitor position when GPS and other location systems are unavailable, and to be able to communicate this position even when out of range of a base monitoring station, for example.

20 **Summary of the Invention**

The present invention therefore provides, in one aspect, a position locating system comprising a radio receiving base station and a plurality of portable radio transmitter/receiver devices each having means for determining an instantaneous global position for said device and adapted to signal said position to the base station, each device also being adapted to monitor transmissions from other devices within the system and to relay said messages from one device to another, whereby a message from a device out of range of the base station can be relayed to the base station.

Preferably, the means for determining position comprises a cellular network and a global positioning system, a cellular communications device provided with means to receive signals from the global positioning system and the cellular network such that the de-

vice uses either or both of the global positioning system and the cellular network to generate accurate positional information concerning the location of the device.

The communications device may be a two-way radio device for enabling speech communication by, for example, a VHF link, but it may alternatively be incorporated into some other personal device carried by the user, for example a cellular telephone, being
5 arranged to operate independently of the telephone. Thus, for example, if the telephone is carried by a child subject to kidnap or other attack, and the attacker switches off the telephone, distress signals can still be transmitted, for example as a result of the child pressing a "panic button", or automatically, for example as a result of detaching the tele-
10 phone from the child's clothing, or as a result of separation from an alerting device carried by the child, for example incorporated into a button or other disguised device. In one embodiment, the communications device is incorporated into a battery for a cellular telephone, being triggered to send a distress signal in response, *inter alia*, to its removal from the telephone. In this way, if the attacker removes the battery from the telephone
15 in an attempt to prevent communication, the distress signal is triggered. It will be understood that an essential element of the distress signal will be a position indicator, based on the last-recorded position from the GPS or other system, as updated, where necessary, by an inertial guidance device, as hereinafter described.

The invention also provides a method of transmitting position data from any one
20 of a plurality of portable radio transmitter/receiver devices to a radio receiving base station, each device having means for determining an instantaneous global position for said device and being adapted to signal said position to the base station, the method comprising monitoring at each device transmissions from other devices within the system and re-
laying said messages from one device to another, whereby a message from a device out of
25 range of the base station can be relayed to the base station.

When the communications device is out of range of the radio-based position determining systems such as GPS and cellular autolocation systems, an inertial guidance system, for example based on a solid-state motion sensor, can continue to calculate changes relative to the last received position, so as to provide a reasonably-accurate estimate of
30 current position which can be relayed to a base station, either routinely to enable position

to be continuously monitored, or on demand, for example in response to an alarm condition initiated by the user of the communications device. Where the communications device is out of range of the base station, communication of the alarm message can be achieved by relaying the message through neighbouring communication devices similarly
5 equipped. While this may be more readily applicable to specialist communications networks, such as police networks, wider application could be achieved by building the necessary transceivers into public network devices. One way of achieving this might be to incorporate the transceivers into a readily-replaceable component such as the battery pack of a mobile telephone or the like. By permitting existing telephones to be easily
10 converted, the availability of neighbouring devices to relay alarm messages and positional information is significantly increased. Also, by providing the transceivers as separate items to the electronics of the mobile telephone, they can continue to operate even when the telephone is switched off.

Brief Description of the Drawings

15 In the drawings, which illustrate exemplary embodiments of the invention:
Figure 1 depicts a schematic diagram indicating the sequence of events resulting from initiation of a request for service in the system according to the invention; and
Figure 2 is a diagram illustrating a position locating device.

Detailed Description of the Illustrated Embodiments

20 The invention relies on a communications device that could be a modified mobile handset or a so-called "blind" device that is capable only of radio communication and does not need to incorporate a speaker, microphone, keypad or screen. In either case, the device is provided with circuitry enabling it to communicate with both a cellular network and a global positioning system. In its simplest implementation, the device may consist of
25 a standard cellular telephone handset provided with a modified rechargeable battery incorporating the global positioning circuitry.

The modified battery could also contain a short-range radio transceiver designed to be activated remotely. This could be achieved upon reception of a uniquely coded signal transmitted from a miniature radio transmitter incorporated in a badge, for example,
30 worn by a child, the transmitter being activated by pressing on the badge. Alternative op-

tions may include the transmitter being incorporated in a unit that can be worn on a belt or other suitable garment, and activated automatically, for example, by incorrect removal of the transmitter from its mounting, or removal at an inappropriate location. The automatic activation may be by mechanical means, but is preferably achieved by some system in which proximity of another separate component prevents activation, whereby removal of the component in excess of a predetermined distance from the transmitter causes activation/triggering of an alert/distress signal.

When the coded signal from the badge or other activating device is received by the handset or other module incorporating the necessary circuitry, the handset/module automatically transmits the location co-ordinates to a dedicated communications centre.

As a significant safeguard against disablement of the device, preferably any other handsets or devices are also triggered to provide auxiliary communication. Taking as an example a communication system within an arena (or other building complex, for example), where personnel are provided with communication devices which also enable the arena management to track the position of the personnel, the location coordinate signals in the tracking mode would be transmitted on a regular basis, the transmission interval being determined by the operator of the base equipment, and would be in a packet format and directed to the base station. This would suitably be via VHF radio. In the event of an emergency (man down, under attack, etc), an alarm message would be sent via the same VHF link but the packet header would be changed to reflect the nature of the message. This change would trigger actions in the software at the base, but also would result in the other communication devices in the system acting to repeat the alarm packet(s), so that, if the communication device sending the alarm message is temporarily out of range of the base station, for example because of r.f. shielding of the signal by the structure of the arena, other communications devices within range of the sending device can relay the alarm packets back to the base station.

Also, during routine tracking mode transmissions (from a given portable communications device) the base station could respond with a handshake packet back to the portable device. The lack of this handshake packet for a predetermined number of cycles would result in the affected device entering an alerting status, but again the packet header

could advise that this was a network tracking packet to be relayed to base station rather than a emergency message.

These varying packet header types and events would be able to initiate various preconfigured actions in the software program running on the base station computer. The
5 absence of packets from any particular unit or units could also initiate various actions.

In the situation where cellular radio is the primary carrier the alarm or alerting message (again by VHF) would be an attempt to duplicate or replace the primary emergency transmission over the cellular link. Thus, if a cellular mobile were deliberately and incorrectly shutdown the VHF alarm/alerting transceiver would hopefully operate for
10 some time and via its limited range recruit other suitably equipped devices to carry its location packets. The "suitably equipped devices" might be fixed hardware located throughout the territory served, for instance police, fire, ambulance stations, every high street, at cellular repeater sites, etc

The whole device, instead of being integrated into a cellular handset, could be
15 concealed from view, for example on a chain worn around the neck. If the device is one of the "blind" devices mentioned above and is truly miniaturised, it can be incorporated into a watch, a watch strap or any other item of apparel or clothing.

It would be possible to trigger operation of the device, for example for the purposes of an emergency alert signal, by detaching it from a carrier on the user's clothing.
20 The triggering can be by a physical separation of contacts, or by sensing the separation of two components; while they are in close proximity, the device remains inert, but when one part is removed from the other by a pre-determined distance, it is switched to the alert state.

Where the system is set up to safeguard assets rather than people, for example
25 lap-top or notebook computers, the device or the transmitter can be incorporated covertly into the casing or into the body of the equipment. For example, one of the fold-out feet of a typical laptop computer can incorporate a switch that can be activated by the user/owner so that unauthorised removal from its present location can trigger a built-in transmitter or device to initiate transmission of the alarm call.

When the device is incorporated into a cellular handset, there will be clear advantages in integrating the hardware necessary for the invention within the handset itself. However, as far as the infrastructure is concerned, only location server software will be required. This can reside on a Serving Mobile Location Centre (SMLC), this being an essential entity already present in mobile/cellular networks.

Figure 1 illustrates the sequence of events. Upon the occurrence of an incident and the subsequent initiation of a signalling sequence (e.g. pressing a "panic" button, automatic activation of a switch indicating unauthorised removal of one or more assets etc) at 1, a uniquely coded signal is transmitted via a radio transceiver 2 to a handset 3 incorporating the communication device forming part of the invention. This, in turn, transmits positional information to a dedicated communications centre 4, to generate a response 5. In a preferred implementation, the initiating transceiver also triggers any other compatible devices 6 in the vicinity to transmit positional data in parallel. As previously mentioned, this enables the tracking system to locate the initiator of the sequence in the event that the device becomes disabled. The positional information is stored in the handset from previous communications with the cellular network 7 and/or the global positioning system 8.

The hybrid system in accordance with the invention is more reliable and robust. Failure of one channel of communication is almost invariably replaced by the other. Accuracy of position information is likely to be improved so that positional accuracy within 5 metres of the correct position is obtained 50% of the time and positional accuracy to within 15 metres is likely 95% of the time.

Figure 2 illustrates a system using a number of portable communications devices 21 in radio communication with a base station 22 and capable of communicating with adjacent such devices within the same system. An example of such a system might be for use in an arena or other public place, as hereinbefore described, or for police or other emergency services, where it is important to know the location of individuals carrying the devices when verbal reports are impossible. Each device 21 comprises a microcomputer 23 controlling its operation, linked to a radio transmitter/receiver 24 and to a global positioning system (GPS) receiver 25 which tracks the position of the device (and hence its

user). Additionally, the device includes a 3-dimensional inertial tracking device 26 which uses solid state motion sensors to track the position of the device relative to each GPS measurement (these being made at regular intervals). If the next scheduled GPS measurement is not possible, because the GPS receiver is not able to receive the transmissions from the satellites, the tracking device 26 continues to monitor the position. The position signals can thus continue to be transmitted back to the base station 22. Typically, these signals will be in the form of data packets transmitted at regular intervals from each communications device 21, and each data packet will include in its header an identifier for the device and an indication of the type of message being transmitted, i.e. to indicate that the packet relates to a routine position indicator, or to indicate some other condition, for example an emergency. The base station 22 may be arranged to send confirmation data packets back to the devices 21 to acknowledge receipt.

If the device 21 is out of range of the base station 22, the confirmation packets are not received, and this can be used to trigger the transmission of packets with different headers indicating that an out-of-range condition has arisen. Neighbouring devices 21 within range and therefore capable of receiving these packages are programmed to recognise them and to re-transmit them, either to the base station 22 if this is in range, or to other devices 21 to enable the packets to be relayed to the base station 22. Similarly, messages from the base station can be relayed to out-of-range devices 21 in this manner.

It will be appreciated that other messages can be relayed across the network of communications devices, permitting signalling between devices which cannot communicate directly with each other. By the use of different packet headers, different messages can be handled in different ways as they are passed around the network. Since it is probable that the latency of such a system would make voice communication unacceptable or impossible, messages will typically be in the form of data packets conveying text messages, position signals and alerting signals for example.

CLAIMS

1. A position locating system comprising a radio receiving base station and a plurality of portable radio transmitter/receiver devices each having means for determining an instantaneous global position for said device and adapted to signal said position to the base station, each device also being adapted to monitor transmissions from other devices within the system and to relay said messages from one device to another, whereby a message from a device out of range of the base station can be relayed to the base station.
2. A position locating system according to Claim 1, wherein said device is a portable cellular telephone handset.
3. A position locating system according to Claim 1 or 2, further comprising switching means adapted to switch communication between the device and said global positioning system and said cellular network, wherein said switching means is activated in response to the signal strength of said global positioning system and said cellular network.
4. A position locating system according to Claim 1 or 2, further comprising switching means adapted to switch communication between the device and said global positioning system and said cellular network, wherein said switching means is activated in response to the accuracy of the position determined by said global positioning system and said cellular network.
5. A position locating system according to any of preceding claim, further comprising trigger means to activate the device to transmit an alarm call to a communications centre.
6. A position locating system according to Claim 5, wherein said trigger means comprises a panic button adapted to transmit a coded signal via a radio transceiver to said device.
7. A position locating system according to Claim 6, wherein said transceiver is adapted to activate other said devices in the vicinity to cause them to transmit an alarm signal.
8. A position locating system according to Claim 5, wherein said trigger means comprises a switch activated by unauthorised movement of equipment provided with a said device.

9. A position locating system according to any preceding claim, further comprising an inertial navigation system to augment the position location capability of the said system.

10. A method of transmitting position data from any one of a plurality of portable radio transmitter/receiver devices to a radio receiving base station, each device having means for determining an instantaneous global position for said device and being adapted to signal said position to the base station, the method comprising monitoring at each device transmissions from other devices within the system and relaying said messages from one device to another, whereby a message from a device out of range of the base station can be relayed to the base station.

11. A method as claimed in Claim 10, wherein each said transmitter/receiver device is a portable cellular telephone handset.

12. A method as claimed in any of Claims 10 or 11, wherein trigger means activate the device to transmit an alarm call to a communications centre.

13. A method as claimed in Claim 12, wherein said trigger means comprises a panic button adapted to transmit a coded signal via a radio transceiver to said device.

14. A method as claimed in Claim 13, wherein said transceiver activates other said devices in the vicinity to cause them to transmit an alarm signal.

15. A method as claimed in Claim 12, wherein said trigger means comprises a switch activated by unauthorised movement of equipment provided with a said device.

16. A method as claimed in any of Claims 10 to 15, further comprising an inertial navigation system to augment the position location capability of the said method.

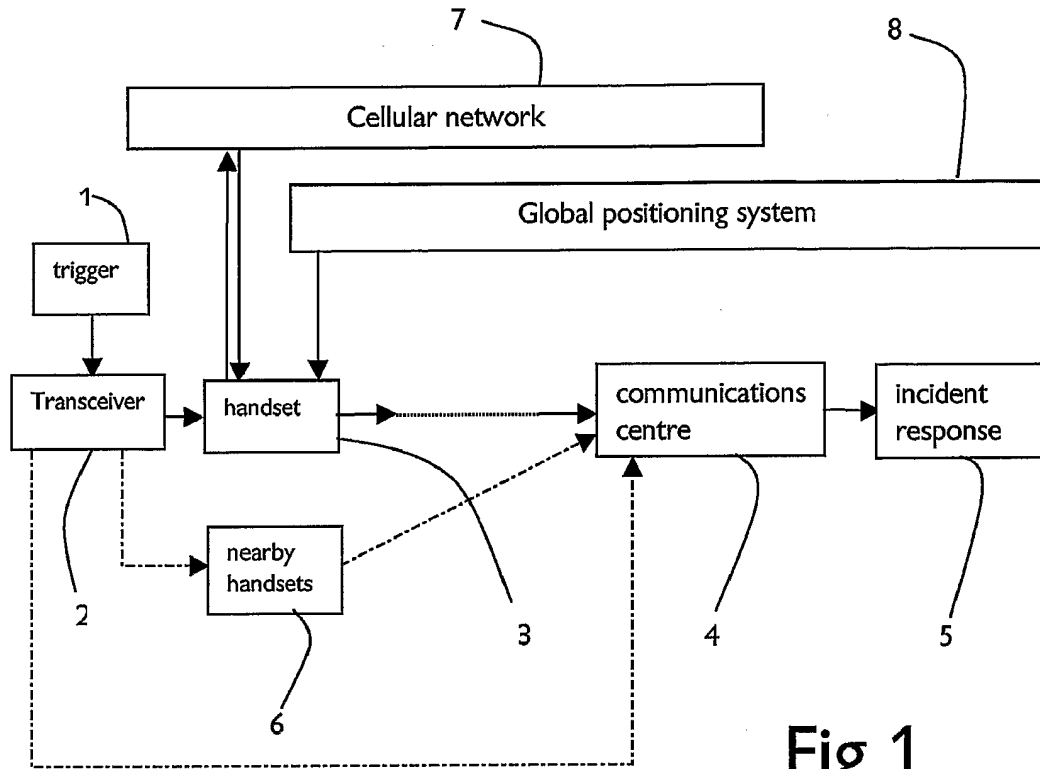

Fig 1

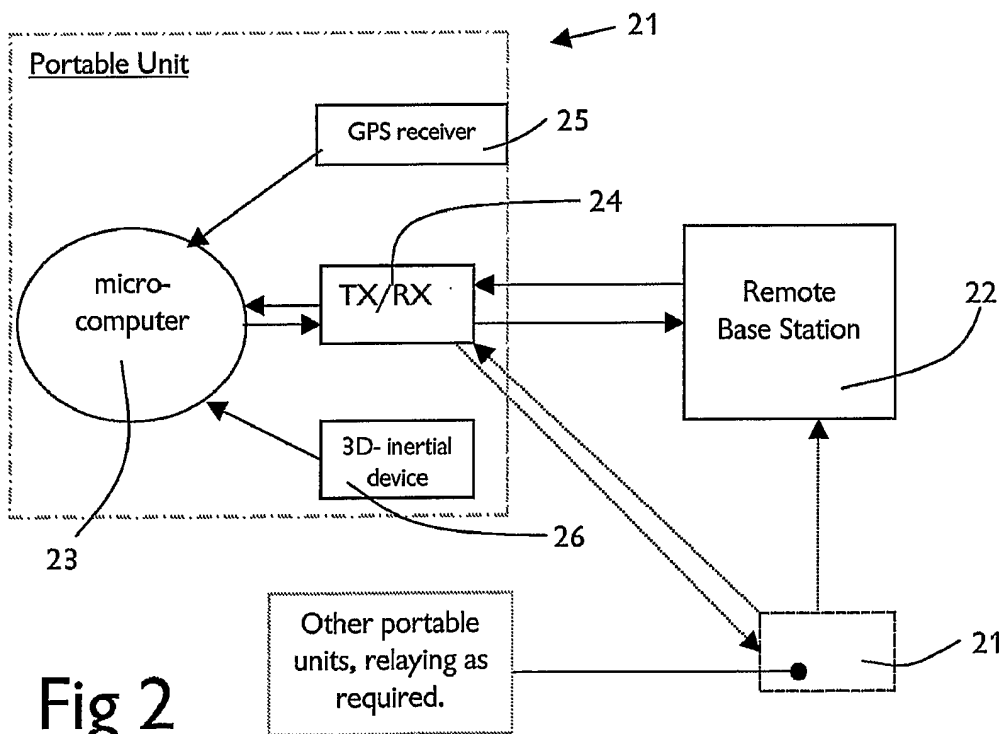

Fig 2

INTERNATIONAL SEARCH REPORT

Inter national Application No
PC 176B2004/050020

A. CLASSIFICATION OF SUBJECT MATTER

IPC 7 G01S5/00 H04L12/56

According to International Patent Classification (IPC) or to both national classification and IPC

B. FIELDS SEARCHED

Minimum documentation searched (classification system followed by classification symbols)

IPC 7 G01S

Documentation searched other than minimum documentation to the extent that such documents are included in the fields searched

Electronic data base consulted during the international search (name of data base and, where practical, search terms used)

C. DOCUMENTS CONSIDERED TO BE RELEVANT

Category *	Citation of document, with indication, where appropriate, of the relevant passages	Relevant to claim No.
X	DE 101 63 990 A1 (RUNGE, BERND; HERPOLSHEIMER, WOLFGANG; FREY, HARTMUT) 27 June 2002 (2002-06-27) paragraph '0031! - paragraph '0082! -----	1-16
X	DE 197 26 956 A1 (MITSUBISHI INTERNATIONAL GMBH, 40476 DUESSELDORF, DE) 8 January 1998 (1998-01-08) column 1, line 42 - column 2, line 68 column 4, line 47 - column 6, line 36 -----	1-16
X	US 2003/072306 A1 (HUNZINGER JASON F) 17 April 2003 (2003-04-17) paragraph '0003! - paragraph '0013! ----- -/--	1-16

Further documents are listed in the continuation of box C.

Patent family members are listed in annex.

* Special categories of cited documents:

A document defining the general state of the art which is not considered to be of particular relevance

E earlier document but published on or after the international filing date

L document which may throw doubts on priority claim(s) or which is cited to establish the publication date of another citation or other special reason (as specified)

O document referring to an oral disclosure, use, exhibition or other means

P document published prior to the international filing date but later than the priority date claimed

T later document published after the international filing date or priority date and not in conflict with the application but cited to understand the principle or theory underlying the invention

X document of particular relevance; the claimed invention cannot be considered novel or cannot be considered to involve an inventive step when the document is taken alone

Y document of particular relevance; the claimed invention cannot be considered to involve an inventive step when the document is combined with one or more other such documents, such combination being obvious to a person skilled in the art.

G document member of the same patent family

Date of the actual completion of the international search

1 February 2005

Date of mailing of the international search report

22/02/2005

Name and mailing address of the ISA

European Patent Office, P.B. 5818 Patentlaan 2
NL - 2280 HV Rijswijk
Tel. (+31-70) 340-2040, Tx. 31 651 epo nl,
Fax: (+31-70) 340-3016

Authorized officer

Dollinger, F

INTERNATIONAL SEARCH REPORT

International Application No
PC 1/GB2004/050020

C.(Continuation) DOCUMENTS CONSIDERED TO BE RELEVANT

Category	Citation of document, with indication, where appropriate, of the relevant passages	Relevant to claim No.
A	WO 03/023439 A2 (DIGITAL ANGEL CORPORATION; ZHOU, PETER, Y; WEBER, LAWRENCE, D; PANG, D) 20 March 2003 (2003-03-20) paragraph '0015! - paragraph '0025! paragraph '0045! - paragraph '0047! -----	1-16
A	US 6 496 111 B1 (HOSACK RAY N) 17 December 2002 (2002-12-17) the whole document -----	1-16
A	US 6 067 018 A (SKELTON ET AL) 23 May 2000 (2000-05-23) column 2, line 22 - column 4, line 67 -----	1-16
A	US 5 552 772 A (JANKY ET AL) 3 September 1996 (1996-09-03) the whole document -----	1-16
A	US 2002/198632 A1 (BREED DAVID S ET AL) 26 December 2002 (2002-12-26) abstract paragraph '0012! -----	1-16

INTERNATIONAL SEARCH REPORT

...formation on patent family members

Inter nal Application No PCT/GB2004/050020
--

Patent document cited in search report	Publication date	Patent family member(s)	Publication date
DE 10163990	A1	27-06-2002	DE 20021899 U1 07-02-2002
			DE 20219388 U1 06-03-2003
			DE 20120909 U1 29-05-2002
			EP 1215509 A2 19-06-2002
DE 19726956	A1	08-01-1998	AT 196397 T 15-09-2000
			AU 3536197 A 14-01-1998
			BR 9709999 A 10-08-1999
			CA 2257392 A1 31-12-1997
			CN 1221527 A ,C 30-06-1999
			WO 9750195 A1 31-12-1997
			DE 19780608 D2 27-05-1999
			DE 59702353 D1 19-10-2000
			DK 908026 T3 08-01-2001
			EP 0908026 A1 14-04-1999
			ES 2151286 T3 16-12-2000
			HK 1018925 A1 14-11-2003
			JP 2000503834 T 28-03-2000
			JP 3074608 B2 07-08-2000
			KR 2000022192 A 25-04-2000
			PL 330643 A1 24-05-1999
			PT 908026 T 28-02-2001
			RU 2176432 C2 27-11-2001
TR 9802506 T2 22-02-1999			
US 6456853 B1 24-09-2002			
US 2003072306	A1	17-04-2003	JP 2003234686 A 22-08-2003
WO 03023439	A2	20-03-2003	US 2003149526 A1 07-08-2003
US 6496111	B1	17-12-2002	NONE
US 6067018	A	23-05-2000	NONE
US 5552772	A	03-09-1996	NONE
US 2002198632	A1	26-12-2002	US 6370475 B1 09-04-2002
			US 6405132 B1 11-06-2002
			US 6526352 B1 25-02-2003
			US 2003191568 A1 09-10-2003
			DE 10149206 A1 06-02-2003
			GB 2373117 A 11-09-2002