



Aug. 25, 1964

G. A. MOORE

3,145,630

APPARATUS FOR MAKING CONTAINERS

Filed Oct. 18, 1962

2 Sheets-Sheet 2

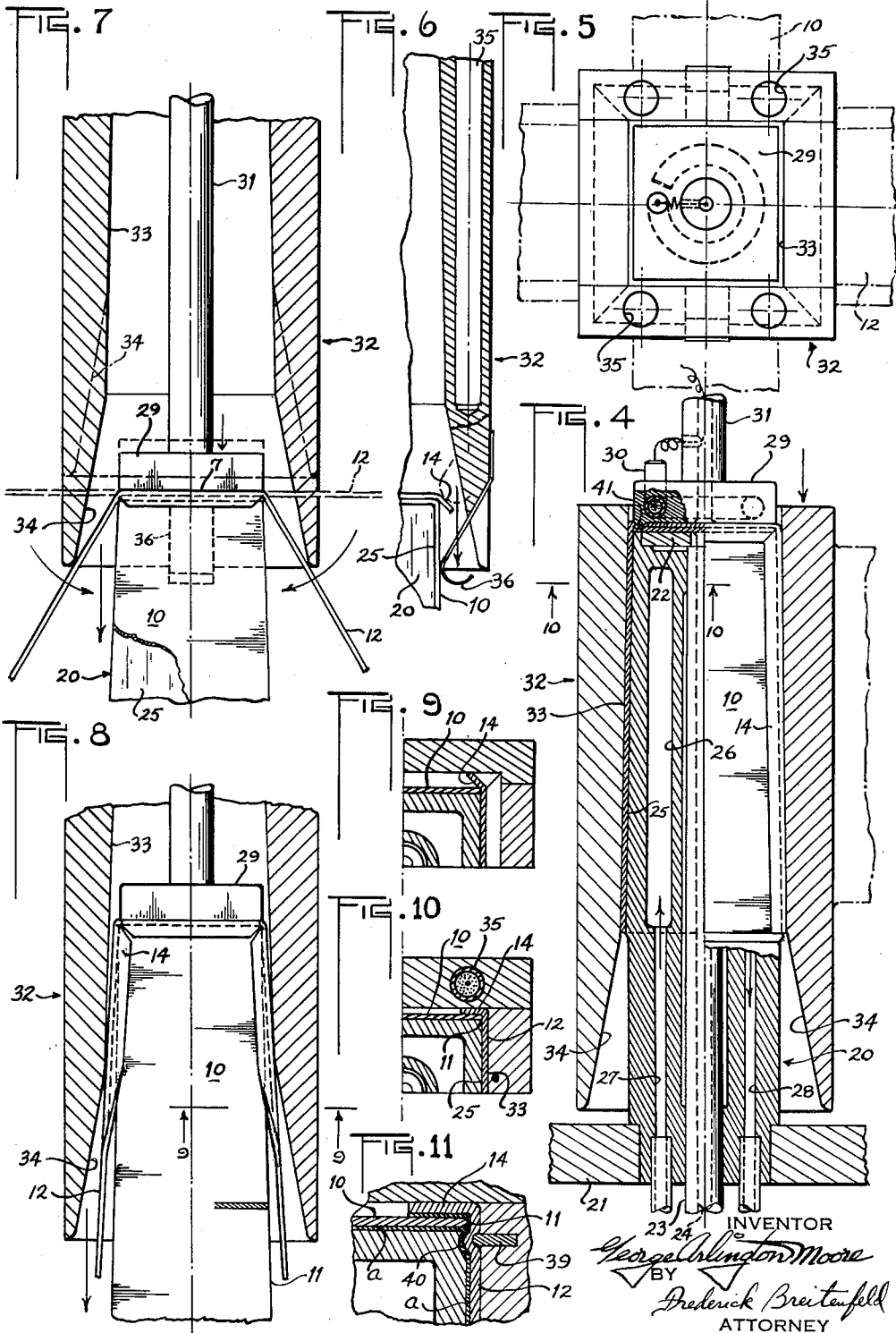

INVENTOR  
*Georgelinton Moore*  
BY  
*Frederick Breitenfeld*  
ATTORNEY

1

3,145,630

**APPARATUS FOR MAKING CONTAINERS**

George Arlington Moore, 230 E. 48th St.,  
New York 17, N.Y.

Filed Oct. 18, 1962, Ser. No. 231,468

9 Claims. (Cl. 93—51)

This invention relates to containers formed of sheet material having thermoplastic properties, and more particularly, it pertains to a novel method and apparatus for forming a substantially rectangular container having an integral flat end closure with a built-in dispenser facility. The novel form of the apparatus is such that the container is completely formed in one operating cycle thereof and is suitable for use by packers in distributing liquid products such as milk and other commodities of commerce.

It is generally known that conventional paper waxed containers used for distribution of milk, cream and other liquid products are notorious leakers and have other undesirable structural defects such as dirt-catching recesses, softening of side walls due to liquid penetration, and in instances, costly handling difficulties due to lack of proper stacking facilities. Many attempts have been made to improve upon these known faults as well as to simplify the complicated methods involved in forming and sealing the folded structure of such containers.

It is therefore a primary object of the present invention to provide an extremely simplified method of forming a container of suitable sheet material having substantially rectangular body side walls embodied with an integral end closure having efficient dispenser utility, the entire structure being formed completely by the action in relationship of three basic tool parts of the apparatus provided.

Another object of the invention is to provide novel apparatus wherein a blank assembly is registered therein and disposed centrally between a male mandrel die and a hollow female die in openly spaced relationship. By movement of the female die over the male die, the panels of the blank assembly are bent along the boundary edges of their central clamped areas and the projecting margins of the panels are articulated to construct the body side walls, the walls being firmly bonded by heat-ironing pressure of the dies during the latter stage of their continuing movement.

A further object of the invention is to provide in the above apparatus die clamping and flute embossing means, to first act upon the central areas of the registered blank assembly, which constructs impervious abutted seams of the integral end closure part of the container.

A still further object of the invention is to form the container by a novel apparatus whereby the construction of connecting panel seams thereof are rendered substantially impervious and strongly reinforced in a manner to greatly enhance the strength of the container to enable it to withstand heavy stacking loads and rough handling.

Other objects and novel features of the invention will appear more fully hereinafter from the following details of description when considered in connection with the accompanying drawings wherein the resultant container and essential parts of its forming apparatus of the invention are illustrated.

In the drawings, wherein similar reference characters refer to similar parts throughout the several views:

FIG. 1 is a partial plan view of the container forming blank assembly preparatory to being operated upon by the apparatus;

FIG. 2 is a fragmentary portion of the blank assembly shown in cross-section taken on line 2—2 of FIG. 1;

FIG. 3 is a perspective view of the container as formed of the blank assembly by the apparatus means;

2

FIG. 4 is a cross-sectional view of the apparatus with the container therein shown in part cross-section and as structurally formed by the actuated movement of member parts of the apparatus;

5 FIG. 5 is a plan view of the apparatus shown in FIG. 4;

FIG. 6 is a fragmentary wall portion of an apparatus part shown in cross-section and provided with another functional part of the apparatus assembly;

10 FIG. 7 is another fragmentary view of the apparatus assembly shown partly in cross-section and showing the first stage of the actuated functional movements of the container forming parts of the apparatus;

15 FIG. 8 is still another fragmentary view of the apparatus partly in cross-section and showing the progressive second stage function taking place during the movement in forming the wall structure of the container;

FIG. 9 is a partial cross-sectional view of fragmentary parts of the apparatus and container taken on line 9—9 of FIG. 8;

20 FIG. 10 is still another similar view of the fragmentary parts and container shown in cross-section and taken on the line 10—10 in FIG. 4;

FIG. 11 is a cross-sectional fragmentary plan view of the apparatus as modified in part and showing the novel seam construction of the container as formed thereby;

25 FIG. 12 is a fragmentary view of the container shown in perspective as formed by the apparatus and further showing the dispenser facility as provided after being opened for dispensing purposes;

30 FIG. 13 is another fragmentary view of the container in perspective and showing the dispenser reclosing facility as provided for retaining its reclosure; and

FIG. 14 is a fragmentary cross-sectional view of the reclosure as provided in retained condition.

35 The particular container to be formed by the method and apparatus of the present invention may be constructed by bringing into registry a blank assembly disposed centrally between the parts of the apparatus when they are in neutral position. The blank assembly 4 as illustrated in FIG. 1 may consist of an elongated strip blank 5, hereinafter referred to as the secondary blank and the crossed strip blank 6, hereinafter referred to as the primary blank. These blanks may be cut of any desired sheet material having thermoplastic properties, e.g., paperboard treated with a suitable thermoplastic material. Fibrous sheet material faced with suitable plastic film material such as polyethylene, polypropylene, or other film-forming material which may be extruded or otherwise applied to the fibrous material is suitable for making the above blanks. The blank assembly as registered provides a central panel section 7, two-ply in thickness, and having boundary lines consisting of the score lines 8 of the primary blank and two parallel underlying side cut edges 9 of the secondary blank as shown in FIG. 2, the blanks being faced with a plastic film "a." The lateral panels 10 of the secondary blank are each provided with longitudinal side cut edges 11 which according to the invention are cut to have a slightly tapered angle which may be defined as being in a range of approximately one-half to one degree or more with respect to the straight parallel side cut edges 9 of the blank. The primary blank is provided with the lateral panels 12 having longitudinal score lines 13 and outwardly thereof the marginal flanges 14 interrupted by the cut notches 15 with blunt apexes at each of the four corners of the central panel 7. The score lines 13 are tapered to coincide with the slightly tapered side edges 11 of the companion blank 5. The underlying central panel portion of the blank 5 is provided with the circular-shaped cut lines 16 and the overlying central panel 7 of the blank 6 is provided with two substantially parallel perforated lines 17 extended across one of the marginal flanges 14 as illus-

trated in FIG. 1. The inner terminal ends of the perforated lines 17 are crossed by the hinge forming score line 18 to be embossed therein when forming the container. The radial cut line 19 is disposed through the marginal flange of the blank 6 for a purpose hereinafter to be functionally described.

The apparatus for carrying out the method of forming the container of the blank assembly consists of a male mandrel die 20 illustrated in FIG. 4. The die may be mounted in stationary position by being supported in a fixed bolster plate 21. The top end wall of the male die is counterbored to receive the shaft mounted stripper plate head 22 utilized for ejecting the formed container from the die. The shaft 23 to which the head plate 22 is mounted may be actuated in any suitable manner to push on the end wall of the completed container and loosen it from the male die. A hole 24 is provided through the shaft to be connected with a source of compressed air utilized for completing the ejection of the formed container by blowing it from the male die. The side walls 25 of the die that correspond to the walls of the container to be formed are tapered slightly outwardly from the top of the die corresponding to the taper provided on the side edges 11 of the secondary blank. The die is also provided with a chamber 26 communicating with an inlet hole 27 and outlet hole 28, each of which is connected with a tube leading to a coolant source of supply for circulation through the chamber. This coolant circulation is provided for the purpose of controlling the temperature of the male die hereinafter to be further described. However, should the male die be made of a particular material having a composition such that will not conduct undue heat above approximately 170° temperature, then the coolant circulating system illustrated could be dispensed with.

A shaft mounted platen die head 29 is provided with means for being heated such as the electrical heating element 30 electrically connected through a temperature control thermostat. The shaft 31 supporting the platen head may be actuated in any suitable manner to perform its intended function hereinafter to be described.

The final major part of the apparatus consists of a hollow form female die 32 having flat interior surface walls 33 parallel to the corresponding walls 25 of the male die. The mouth end of the female die, however, is flared outwardly, each of the four side walls 34 thereof defining the mouth being tapered at an angle of approximately 12 degrees, more or less. The walls 34 terminate upwardly at a junction with the bottom ends of the walls 33 of the die. The flared mouth portion of the die is provided for a novel functional purpose of the invention hereinafter to be fully described. The walls 33 of the die are provided with electrical heating elements to be inserted into each of the four holes 35 illustrated in FIGS. 5, 6 and 10, the element being shown inserted in the latter figure. These elements are to be suitably connected through a temperature control thermostat leading to an electrical current supply. The female die may be mounted in any suitable manner desired. For example, it may be flexibly mounted in a slideable cross head assembly that may be actuated by a pneumatic air cylinder or a cam actuated toggle mechanism arranged to move the die through its required stroke.

To form the structure of the container, the blanks illustrated in FIG. 1 may be fed separately into the apparatus and registered therein, or they may be fed to the apparatus in the assembled condition shown in FIG. 1. The latter method of feeding may be accomplished by first feeding each of the two blanks into a conveyor open pocket frame wherein they are assembled and which brings the assembly to the apparatus. The conveyor link belt frame arrangement operates continuously in its indexing movements in order to handle a succession of blank assemblies and its operation is in timed relationship with the cycle of operation of the apparatus. While the blanks are in the con-

veyor, the thermoplastic properties of the conveyed blanks can be preactivated to any extent desired by radiant heat directed upon them prior to their being delivered to the apparatus.

FIG. 7 illustrates the beginning of a cycle of operation of the container forming apparatus, the blanks having been registered centrally over the top end surface of the male die. The heated platen head 29 is first moved downwardly to tightly clamp, emboss, and bond areas of the layers of the central panel 7 of the blank assembly disposed upon the top end surface of the male die 20. The female die 32 then moves downwardly to begin its telescopic engagement with the male die whereby the opposed pair of spring prongs 36 that are provided through two of the opposed walls 34 first contacts the panels 10 of the secondary blank 5 causing these panels to be bent downwardly and inwardly upon the coincident side walls 25 of the male die as illustrated in FIG. 6. As the female die progresses downwardly its flared mouth bottom end bends the panels 12 of the primary blank 6 downwardly and inwardly towards the coincident side walls 25 of the male die. The flared mouth of the female die then begins to articulate the marginal flange portions 14 of the panels 7 and 12 progressively inward as illustrated at this stage in FIGS. 8 and 9. Further progression of the female die in its movement brings the panels 12 inwardly against the corresponding side walls 25 of the male die and the marginal flanges 14 of the panels 12 to a position at right angles thereto and upon the corresponding exterior surfaces of the pre-positioned panels 10 as illustrated in FIG. 10. At the instant of the meeting of the inner plastic surfaces of the panels 12 with the surface of the male die, the right angular articulation of the marginal flanges is simultaneously completed. The walls 33 of the die due to their defined taper begin to heat and slide iron the exterior surfaces of the articulated flanges and at the same time progressively compress the panels 12 into tight and heat-fused abutments upon the opposing side edges 11 of the flange seating panels 10. As the heat-ironing takes place the swedging high pressure exerted upon the contacted wall surfaces of the container structure is progressively increased to its maximum set point that is governed by the set stop end of the female die stroke. During the dwell of the die at this stop, heat and compression act to firmly bond the flanges and wall junction abutments of the formed structure into strongly reinforced and substantially impervious seam forming relationship. The duration of each cycle of operation of the female die when it is regulated at a temperature of approximately 500° F. may approximate one second. However by utilizing radiant heat for pre-activating the blanks prior to the operating cycle of forming the container, the dwell part of the cycle may be reduced substantially whereby the operating time of the entire cycle of the apparatus may be a fraction of one second. Upon completion of the cycle the female die is then actuated to retract from the male die, and the platen head die then retracts. At this point of retraction, the stripper shaft 23 is actuated whereby its head plate 22 pushes against the formed integral end closure of the container loosening it from the male die followed by an actuated jet of compressed air directed through the hole 24 of the shaft blowing the container free of the male die.

The completed substantially rectangular shaped container 37 as formed by the apparatus is illustrated in FIG. 3. The bottom of the container is shown in closed condition after being filled with its intended liquid product. The bottom may be closed by capping it with a preformed aluminum closure 38 sealed with a plastic resin or by closure forming folded elements that may be provided on the container forming blanks. In the latter case the folded elements may be heat sealed in hermetic seam forming relationship.

To meet heavy duty requirements of the container such as those having a capacity of ½ gallon or gallon of milk or other liquid, a modification is provided in the seam

5

formed structure of the container as illustrated in FIG. 11. The modification consists of providing a spline 39 inserted into a longitudinally aligned keyway-like slot disposed in each of the slightly tapered side walls of the female die. The male die is provided with corresponding longitudinal grooves 40 disposed adjacent each of the corner ends of the side walls thereof as shown in FIG. 11. When forming the container and at the stage where heat ironing of these side walls begin, the projecting nose of each spline is progressively forced transversely into the exterior surface of the side wall panels 12 of the container throughout the length thereof. This exertion forces the material contacted by the spline into the groove 40 causing the plastic film "a" on the panel to form an offset shoulder next to the abutted corner edge of the panel 10. The meeting surfaces of the plastic films "a" on the inner surfaces of the panels 10 and 12 are accordingly heat-fused and merged into blended union at these junctions thereby resulting in a tightly reinforced impermeable seam structure. The flange 14 heat-sealed in bonded union upon the panel 10 serves to sandwich the abutted side edges 11 between the flange and offset shoulder and enclose these edges completely within plastic film which lines the container walls. It is to be noted that a pair of parallel beaded ribs 41 are also provided on the bottom surface of the platen head die 29 as shown in FIG. 4. The pressure exerted by the panel clamping movement of the platen head 29 compacts and swedges the parallel side edges 9 of the underlying central panel layer on the end face of the male die into firm heat-fused abutments upon the opposing inner surfaces of the side wall panels 12 in forming the container. Hence, a pair of parallel opposed aligned grooves 42 are embossed inwardly into the exterior surface of the integral end wall closure of the constructed container.

In the structure of the container as formed by the teaching of the present invention there is embodied therein the complete formation of the dispenser facility hereinbefore mentioned. This dispenser arrangement is illustrated in FIG. 12 and is shown after it has been opened for dispensing purpose. The hinge line 18 has been embossed into the panel 7 by the facilities provided on the platen head die 29 while forming the container. The pressure as may be applied upon selective surface areas of the severable panel section 43 exerted by the platen head will stiffen it in a manner that will resist its otherwise warping or bowing tendencies. This feature, in addition to forming the hinge line 18 insures a flat and efficient reclosure of the dispenser as illustrated in FIGS. 13 and 14. The reclosure is retained by inserting the severed tab, formed by the cut line 19 in the flange, into the dispenser orifice at the edge 44 thereof as illustrated in FIGS. 13 and 14. The liquid product such as milk in the filled container will pour from the dispensing orifice shown in FIG. 12, when the container is tilted, without fouling the side wall under the pouring stream of liquid as it is shut off.

When forming the container intended for holding lubricating oil for service station dispensing, the bottom of the container may be punctured to insert the usual spout, and the top dispenser end closure may serve as an openable air vent utilized at the moment of dispensing the oil from the container resulting in a rapid and thorough discharge free of back pressure.

While a particular form of the container and apparatus of the present invention has been illustrated and described, it will be understood, by those skilled in the art, that various changes may be made therein without departing from the general concepts constituting the invention. Reference will therefore be had to the appended claims for a definition of the limits of the invention.

What is claimed is:

1. Apparatus for forming a substantially rectangular container from a pair of crossed blanks, said blanks having central end-forming panels in superposed relation and

6

side-forming panels extending outwardly from said end-forming panels, and one of said blanks having longitudinally extending lateral flanges adapted to be folded upon and bonded to the outer faces of the side-forming panels of said other blank, comprising:

a pair of elongated cooperable male and female dies and means for producing relative longitudinal movement between said dies,

said male die having an upper horizontal face substantially conforming in size and shape to the cross-sectional area of said container,

two pairs of substantially vertical side walls, the walls of each pair being substantially parallel to each other and perpendicular to the other pair, said side walls extending downwardly from said horizontal face a distance at least equal to the height of said container, a head movable with respect to said male die and cooperable with said horizontal face for clamping the superposed end-forming panels of a pair of crossed blanks between them preparatory to formation of the container; and

said female die having two pairs of substantially vertical inner walls corresponding to the side walls of said male die, said inner walls extending vertically for a distance at least equal to the height of said container from a lower horizontal margin where said horizontal face of said male die first engages said substantially vertical inner walls, and said two pairs of inner walls of said female die terminating at their lower ends in four side walls which are flared outwardly and downwardly from said margin to engage the flanges of said one blank and thereby initiate the turning of said flanges over the outer faces of the side-forming panels of said other blank as said dies move into nesting relationship completing said turning at said margin.

2. Apparatus according to claim 1 including a pair of prongs extending inwardly of an opposed pair of said flared walls below said margin for folding the side-forming panels of said other blank against said male die before the side forming walls of said one blank are so folded by said female die.

3. Apparatus for forming a substantially rectangular container from a pair of crossed blanks, said blanks having central end-forming panels in superposed relation and side-forming panels extending outwardly from said end-forming panels, and one of said blanks having longitudinally extending lateral flanges adapted to be folded upon and bonded to the outer faces of the side-forming panels of said other blank, comprising:

a pair of elongated cooperable male and female dies and means for producing relative longitudinal movement between said dies,

said male die having an upper horizontal face substantially conforming in size and shape to the cross-sectional area of said container,

two pairs of substantially vertical side walls, the walls of each pair being substantially parallel to each other and perpendicular to the other pair, said side walls extending downwardly from said horizontal face a distance at least equal to the height of said container, a head movable with respect to said male die and cooperable with said horizontal face for clamping the superposed end-forming panels of a pair of crossed blanks between them preparatory to formation of the container;

said female die having two pairs of substantially vertical inner walls corresponding to the side walls of said male die, said inner walls extending vertically for a distance at least equal to the height of said container, and said inner walls of said female die terminating at their lower ends in outwardly and downwardly flared walls which engage the flanges of said one blank and thereby initiate the turning of said flanges over the outer faces of the side-forming panels of

said other blank as said dies move into nesting relationship, and  
 two parallel ridges on each of two opposed inner walls of said female die, said ridges extending lengthwise of said die and each ridge being disposed close to one of the edges of its respective wall, and cooperable grooves in the corresponding side walls of said male die, whereby as said dies move into nesting relationship during container formation said ridges will press the container material into said grooves thereby forming internal shoulders enclosing the edges of the blank within the container.

4. Apparatus for forming a container from a pair of crossed blanks, said blanks having central end-forming panels in superposed relation and side-forming panels extending outwardly from said end-forming panels, comprising a pair of elongated cooperable male and female dies, said dies having corresponding outer and inner walls respectively conforming to the contour of the finished container produced by them, means for moving said dies into nesting engagement, means for clamping the end-forming panels of said blanks on top of said male die before said dies begin moving toward engagement, and means projecting inwardly from an opposed pair of said female die walls for bending upon movement of said dies toward each other the side-forming panels of one of said blanks downwardly before the side-forming panels of the other of said blanks is so bent.

5. Apparatus for forming a container from a pair of crossed blanks, said blanks having central end-forming panels in superposed relation and side-forming panels extending outwardly from said end-forming panels, and one of said blanks having longitudinally extending lateral flanges adapted to be folded over the side cut edges of the other blank and bonded to the outer faces thereof, comprising a pair of elongated cooperable male and female dies, means for moving said dies into nesting relationship, said dies having corresponding outer and inner walls respectively conforming to the contour of the finished container produced by them, an opposed pair of said inner walls being provided with a ridge extending close and parallel to each edge of each wall of said pair, and cooperable grooves in the corresponding outer walls of said male die, whereby as said dies move into nesting relationship with said blanks between them said ridges will press the material of the side-forming panels of said one blank into said grooves to form internal shoulders, a side cut edge of said other blank being enclosed between each of said shoulders and said flange closest to it.

6. Apparatus for forming a substantially rectangular shaped container from a pair of crossed blanks superposed at their respective central panel portions to constitute a base end forming closure, and side wall forming panels laterally extending outwardly thereof, one of said blanks having longitudinally extended marginal flanges adapted to be articulated upon and bonded to the corresponding surface areas of the side wall forming panels of said other blank, comprising:

- a pair of elongated cooperable male and female dies and means for producing longitudinal movement of one die with respect to the other,
- said male die having its top end face substantially conforming in size and shape to the general horizontal cross-sectional area of said container,
- two pairs of substantially vertical side walls, each pair being in opposed relationship and extending downwardly from said top end face at least equal to the height of said container,

a heated platen die head movable with respect to said male die and cooperable with said top end face thereof for clamping, heating and compressing said base end forming closure preparatory to formation of the container; and

said female die being heated and having two pairs of substantially vertical inner wall surfaces corresponding to the side walls of said male die, said inner wall surfaces being extended longitudinally commensurate with the height of said container from a lower margin where said top end face of said male die first engages said substantially vertical inner wall surfaces, then being flared outwardly and downwardly from said margin so that the open bottom mouth of the female die is widespread to thereby initiate the articulation of said marginal flanges over and upon the exterior faces of the side wall forming panels of said other blank prior to heat ironing of the articulated flanges into bonded relationship as said dies move into nesting relationship.

7. Apparatus for forming a container from a registered blank assembly having an end closure forming panel and side wall forming panels arranged in opposing pairs, one of said pair and the end closure forming panel having longitudinally extending marginal flanges adapted to be articulated at substantially right angles over the side cut edges of the other pair of said wall forming panels and bonded upon the adjacent outer surface areas from said edges, comprising a pair of elongated cooperable male and female dies, the latter die provided with heating means, means for moving said dies into nesting relationship, the dies having corresponding outer and inner wall surfaces respectively conforming to the substantially rectangular contour shape of the finished container formed by the dies, said female die being provided with a widespread mouth portion extending from said inner wall surfaces in the direction from which said male die moves in a nesting movement, said mouth portion including four outwardly flaring walls, whereby as said dies move into contacting nesting relationship with said blank assembly between them said flanges are first articulated within said mouth portion then heat ironed into bonded relationship by the co-acting of said outer surfaces of said male die and said inner wall surfaces of said female die in seam forming relationship.

8. Apparatus for forming a container as set forth in claim 7 wherein the corresponding outer and inner wall surfaces of said dies disposed upwardly of said widespread mouth thereof are sloped outwardly and downwardly with a slightly tapered draft in order to heat iron said first articulated flange portions of the formed side walls of the container as the dies move into final co-acting relationship.

9. Apparatus for forming a container according to claim 7 wherein said female die is provided with heating means for bonding the seam forming relationship of the formed structure of the container, said male die being provided with coolant control means to prevent overheating by its co-action with said heated female die.

#### References Cited in the file of this patent

##### UNITED STATES PATENTS

2,580,189	Pagendarm	Dec. 25, 1951
2,843,027	Sevison	July 15, 1958
2,864,287	Johnson et al.	Dec. 16, 1958
2,898,822	Moore	Aug. 11, 1959
3,047,053	Howard	July 31, 1962