

Jan. 23, 1951

J. K. WARNER  
CATTLE GUARD

2,539,214

Filed Oct. 4, 1948

2 Sheets-Sheet 1

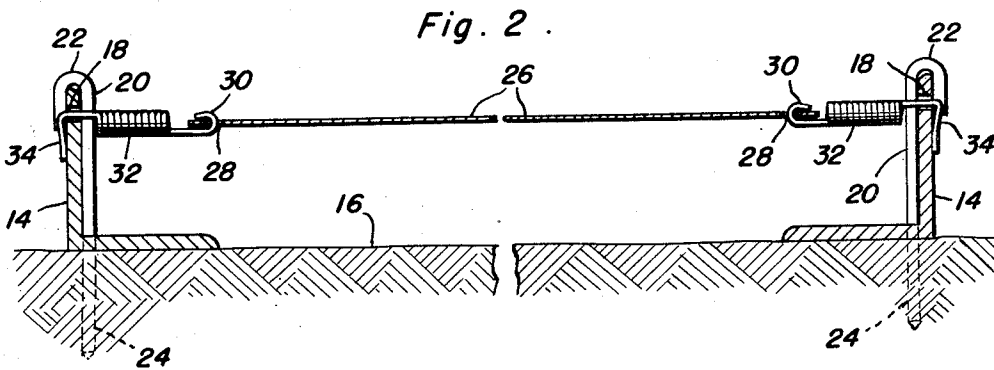
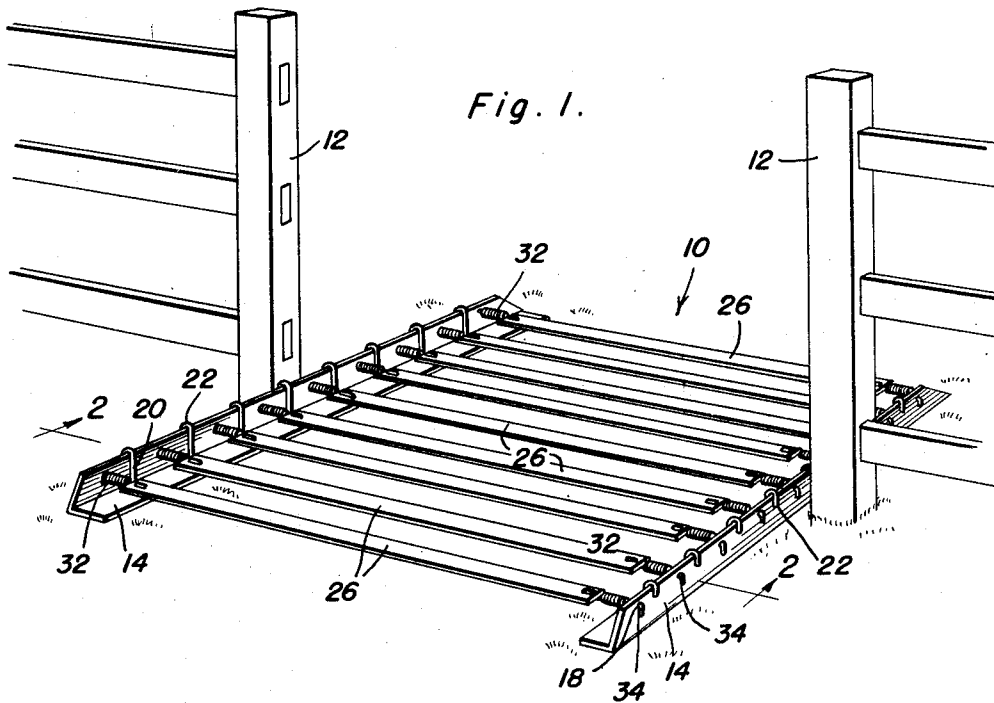

Inventor

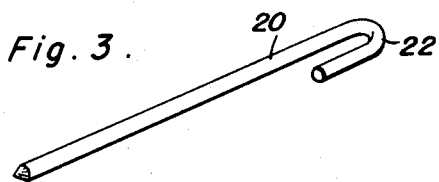

John K. Warner

By *Clarence W. O'Brien*  
*and Harvey B. Jacobson*  
Attorneys

Jan. 23, 1951

J. K. WARNER  
CATTLE GUARD

2,539,214

Filed Oct. 4, 1948

2 Sheets-Sheet 2

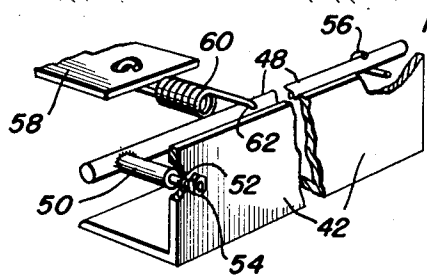
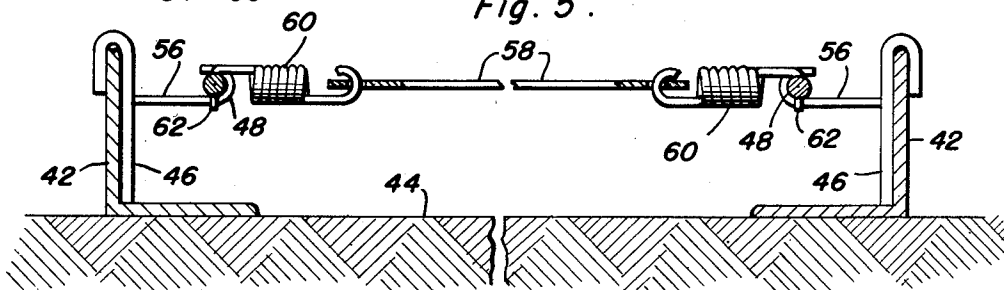
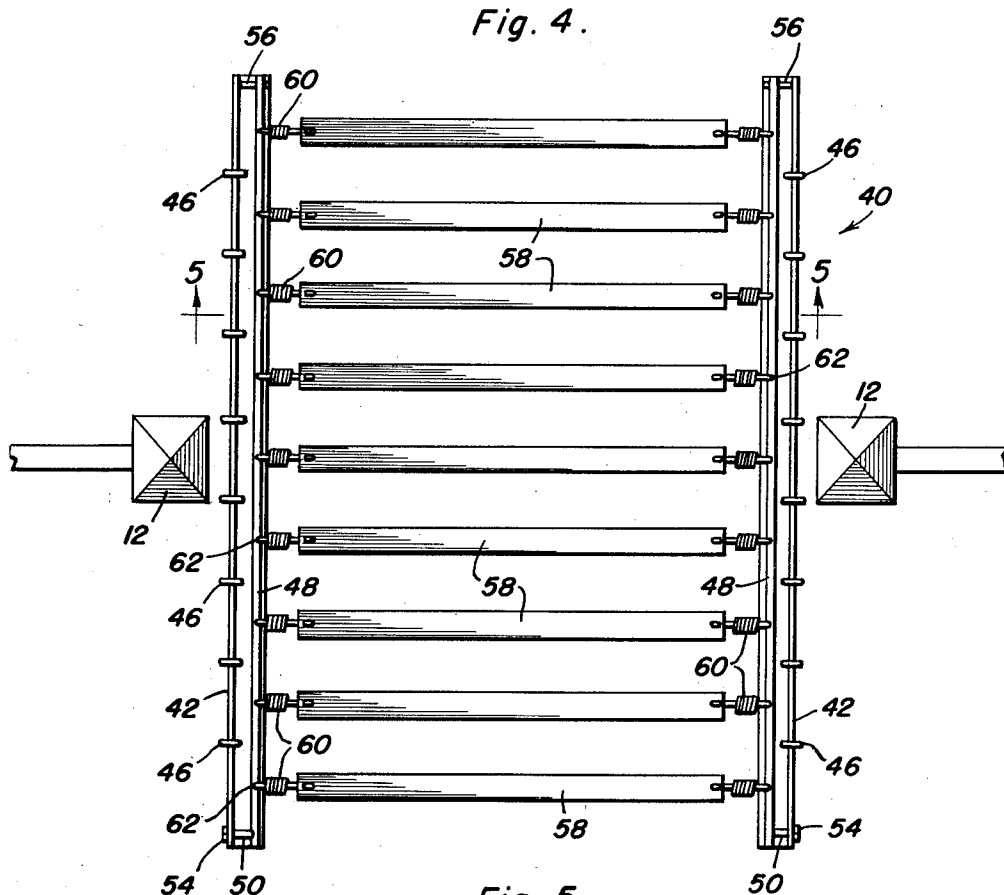

John K. Warner  
INVENTOR.

BY *Thomas A. O'Brien*  
*and Harvey B. Jacobson*  
Attorneys

# UNITED STATES PATENT OFFICE

2,539,214

## CATTLE GUARD

John K. Warner, Tucson, Ariz.

Application October 4, 1948, Serial No. 52,665

1 Claim. (Cl. 256—14)

1

This invention relates to new and useful improvements and structural refinements in cattle guards, and the principal object of the invention is to discourage the travel of cattle through gate openings and similar passages.

This object is achieved by the provision of a cattle guard structure embodying a set of spaced straps extending transversely of the passage which is to be guarded and supported by resilient means in an elevated position, whereby the spaces between the straps create an impression of depth and insecure footing and thus discourage the travel of cattle thereover.

An important feature of the invention resides in the resilient mounting of the straps which permits them to be depressed to the ground to facilitate passage of persons and vehicles thereover, but which automatically returns the straps to their elevated positions as soon as such persons or vehicles have passed.

Another feature of the invention involves the provision of means for expeditiously separating or removing the straps from their supporting structure, whereby cattle may travel through the gate opening or passage when so desired, thus eliminating the provision of another gate.

Important advantages of the invention lie in its simplicity of construction, and in its adaptability to economical manufacture.

With the above more important objects and features in view and such other objects and features as may become apparent as this specification proceeds, the invention consists essentially in the arrangement and construction of parts as illustrated in the accompanying drawings, in which:

Figure 1 is a perspective view of the invention, illustrating the same in situ in a gate opening or passageway.

Figure 2 is a cross sectional view taken substantially in the plane of the line 2—2 in Figure 1.

Figure 3 is a perspective view of one of the securing hooks used in the invention.

Figure 4 is a top plan view, similar to that shown in Figure 1, but illustrating a modified embodiment of the invention.

Figure 5 is a cross sectional view, taken substantially in the plane of the line 5—5 in Figure 4, and

Figure 6 is a fragmentary perspective detail, partially broken away, illustrating the mounting of the straps shown in Figures 4 and 5.

Like characters of reference are employed to designate like parts in the specification and throughout the several views.

2

Referring now to the accompanying drawings in detail, and more particularly to Figures 1, 2 and 3, the invention consists of a cattle guard designated generally by the reference character 10, the same being intended for positioning in a passage or a gate opening, such as for example exists between a pair of fence posts 12, as illustrated in Figure 1.

The cattle guard 10 embodies in its construction a pair of spaced, substantially parallel side members, preferably assuming the form of angle bars 14 which have horizontal flanges resting upon the ground 16 and upstanding flanges formed with rows of apertures 18, as will be clearly apparent.

The angle bars 14 are secured to the ground 16 by a plurality of hooks 20, as best shown in Figure 3, the bill portions 22 of these hooks engaging upper edge portions of the vertical flanges 20 of the angle bars and extending through apertures in the horizontal flanges into the ground, as indicated at 24 (see Fig. 2).

The essence of novelty of the invention resides in the provision of a set of spaced parallel straps 26 formed from suitable material, these straps having end portions formed with suitable apertures 28 to accommodate hook-shaped ends 30 of a set of tension springs 32, as is best shown in Figure 2.

One of the springs 32 is, of course, provided at each end of each of the straps 26, and the outer end portions of the springs terminate in hook-shaped extremities 34 which are removably anchored in the aforementioned apertures 18.

By virtue of this arrangement, that is, by virtue of the springs 32 and by virtue of their attachment to the angle bars 14, the straps 26 are normally retained in an elevated position above the ground 16, as is best shown in Figure 2, in which they discourage the travel of cattle through the gate as has been already explained. However, persons or vehicles may readily travel over the guard by simply depressing, by their weight, the straps 26 to the ground.

Referring now to the modified embodiment of the invention illustrated in the accompanying Figures 4, 5 and 6 and designated by the general reference character 40, the same embodies in its construction a pair of spaced, substantially parallel side members including angle bars 42 similar to the aforementioned bars 14 but devoid of the apertures 18 with which the bars 14 are formed.

The angle bars 42 are secured to the ground 44 by a plurality of hooks 46 (similar to the

3

aforementioned hooks 20), but it is to be noted that the side members of this embodiment also include suitable rods or rails 48 which are disposed at the "inside" of the bars 42, as is best shown in Figure 5.

The rods 48 are provided at one end thereof with laterally projecting studs 50, the latter having diametrically reduced end portions 52 (see Figure 6) which removably extend through the bars 42 and are retained in position by the nuts 54. The remaining end portions of the rods 48 are removably receivable in substantially J-shaped hooks 56 secured to the bars, as shown.

In this embodiment of the invention, a set of flexible straps 58 is also provided, these being similar to the aforementioned straps 26 and being equipped at the ends thereof with tension springs 60 which, in turn, have angulated end portions 62 receivable in suitable apertures formed in the rods 48. In this manner, the rods 48 normally retain the straps 58 in their elevated positions, but when it is desired to pass cattle through the gate, the straps 58 may be readily removed by simply detaching the rods 48 from the angle bars 42 upon removing the nuts 54 and disengaging the rods from the hooks 56.

It is believed that the advantages and use of the invention will be clearly apparent from the foregoing disclosure and accordingly, further description thereof at this point is deemed unnecessary.

Having described the invention, what is claimed as new is:

In a cattle guard, the combination of a pair of spaced angle bars adapted to be positioned

4

on the ground to extend longitudinally through a gateway, said angle bars having vertical flanges and horizontal ground engaging flanges provided at the lower edges of the vertical flanges with a plurality of vertical apertures, a set of inverted hooks having bill portions in sustaining engagement with upper edge portions of said vertical flanges, said hooks extending downwardly at one side of the vertical flanges and through said apertures into the ground whereby to secure said angle bars in position, and a plurality of depressible straps extending transversely between the angle bars and resiliently connected to the vertical flanges thereof whereby to provide insecure footing for animals but facilitate passage of vehicles longitudinally of the guard.

JOHN K. WARNER.

#### REFERENCES CITED

The following references are of record in the file of this patent:

#### UNITED STATES PATENTS

Number	Name	Date
750,524	Dawson	Jan. 26, 1904
984,001	Ingraham	Feb. 14, 1911
1,580,185	West	Apr. 13, 1926
1,757,024	Solis	May 6, 1930
1,977,370	Allen	Oct. 16, 1934

#### FOREIGN PATENTS

Number	Country	Date
4,052 of 1926	Australia	Sept. 30, 1926