



INTERNATIONAL APPLICATION PUBLISHED UNDER THE PATENT COOPERATION TREATY (PCT)

<p>(51) International Patent Classification ⁷ : H03G 3/30, 1/00</p>	<p>A1</p>	<p>(11) International Publication Number: WO 00/08752 (43) International Publication Date: 17 February 2000 (17.02.00)</p>
<p>(21) International Application Number: PCT/US99/14433 (22) International Filing Date: 25 June 1999 (25.06.99) (30) Priority Data: 09/129,854 6 August 1998 (06.08.98) US (71) Applicant: ERICSSON INC. [US/US]; 7001 Development Drive, P.O. Box 13969, Research Triangle Park, NC 27709 (US). (72) Inventor: FREED, John, G.; 8909 Lindenshire Road, Raleigh, NC 27615 (US). (74) Agents: O'SULLIVAN, Timothy, J. et al.; Myers, Bigel, Sibley & Sajovec, P.A., P.O. Box 37428, Raleigh, NC 27627 (US).</p>		<p>(81) Designated States: AE, AL, AM, AT, AT (Utility model), AU, AZ, BA, BB, BG, BR, BY, CA, CH, CN, CU, CZ, CZ (Utility model), DE, DE (Utility model), DK, DK (Utility model), EE, EE (Utility model), ES, FI, GB, GE, GH, GM, HR, HU, ID, IL, IN, IS, JP, KE, KG, KP, KR, KZ, LC, LK, LR, LS, LT, LU, LV, MD, MG, MK, MN, MW, MX, NO, NZ, PL, PT, RO, RU, SD, SE, SG, SI, SK, SK (Utility model), SL, TJ, TM, TR, TT, UA, UG, UZ, VN, YU, ZA, ZW, ARIPO patent (GH, GM, KE, LS, MW, SD, SL, SZ, UG, ZW), Eurasian patent (AM, AZ, BY, KG, KZ, MD, RU, TJ, TM), European patent (AT, BE, CH, CY, DE, DK, ES, FI, FR, GB, GR, IE, IT, LU, MC, NL, PT, SE), OAPI patent (BF, BJ, CF, CG, CI, CM, GA, GN, GW, ML, MR, NE, SN, TD, TG).</p> <p>Published <i>With international search report.</i></p>

(54) Title: SYSTEMS AND METHODS FOR MANAGEMENT OF CURRENT CONSUMPTION AND PERFORMANCE IN A RECEIVER DOWN CONVERTER OF A WIRELESS DEVICE

(57) Abstract

Methods, systems and computer program products are provided which control the operation of a receiver of a wireless device so as to reduce the power consumption of the receiver by setting the third order intercept point of a low noise amplifier based upon at least one of a strength of a signal received by the wireless device or a transmission power of a transmitter of the wireless device. Furthermore, the gain of the low noise amplifier may also be set based upon received signal strength or transmitter power. Also, the gain of an amplifier associated with a mixer of the receiver may be set based upon received signal strength or transmitter power. Preferably, multiple power modes are provided to tailor the power consumption to the operating conditions of the wireless device.

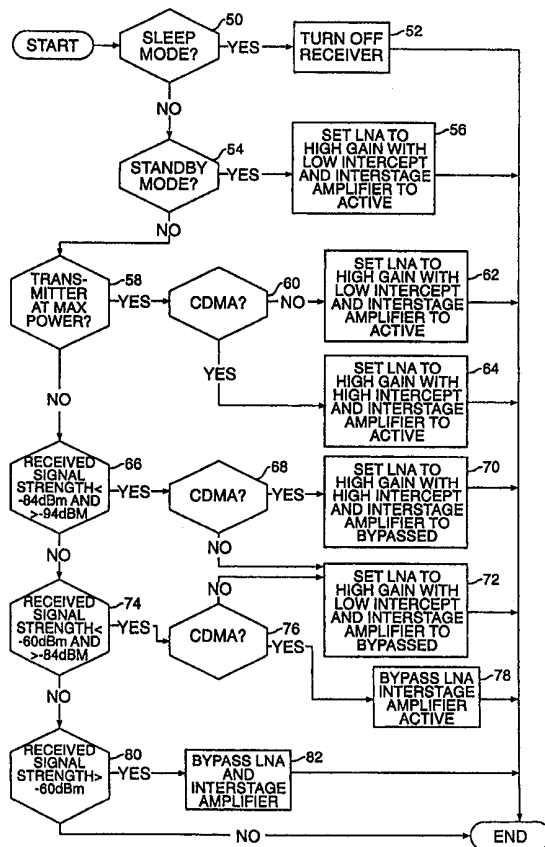

FOR THE PURPOSES OF INFORMATION ONLY

Codes used to identify States party to the PCT on the front pages of pamphlets publishing international applications under the PCT.

AL	Albania	ES	Spain	LS	Lesotho	SI	Slovenia
AM	Armenia	FI	Finland	LT	Lithuania	SK	Slovakia
AT	Austria	FR	France	LU	Luxembourg	SN	Senegal
AU	Australia	GA	Gabon	LV	Latvia	SZ	Swaziland
AZ	Azerbaijan	GB	United Kingdom	MC	Monaco	TD	Chad
BA	Bosnia and Herzegovina	GE	Georgia	MD	Republic of Moldova	TG	Togo
BB	Barbados	GH	Ghana	MG	Madagascar	TJ	Tajikistan
BE	Belgium	GN	Guinea	MK	The former Yugoslav Republic of Macedonia	TM	Turkmenistan
BF	Burkina Faso	GR	Greece	ML	Mali	TR	Turkey
BG	Bulgaria	HU	Hungary	MN	Mongolia	TT	Trinidad and Tobago
BJ	Benin	IE	Ireland	MR	Mauritania	UA	Ukraine
BR	Brazil	IL	Israel	MW	Malawi	UG	Uganda
BY	Belarus	IS	Iceland	MX	Mexico	US	United States of America
CA	Canada	IT	Italy	NE	Niger	UZ	Uzbekistan
CF	Central African Republic	JP	Japan	NL	Netherlands	VN	Viet Nam
CG	Congo	KE	Kenya	NO	Norway	YU	Yugoslavia
CH	Switzerland	KG	Kyrgyzstan	NZ	New Zealand	ZW	Zimbabwe
CI	Côte d'Ivoire	KP	Democratic People's Republic of Korea	PL	Poland		
CM	Cameroon	KR	Republic of Korea	PT	Portugal		
CN	China	KZ	Kazakistan	RO	Romania		
CU	Cuba	LC	Saint Lucia	RU	Russian Federation		
CZ	Czech Republic	LI	Liechtenstein	SD	Sudan		
DE	Germany	LR	Liberia	SE	Sweden		
DK	Denmark			SG	Singapore		
EE	Estonia						

SYSTEMS AND METHODS FOR MANAGEMENT OF CURRENT
CONSUMPTION AND PERFORMANCE IN A RECEIVER
DOWN CONVERTER OF A WIRELESS DEVICE

Field of the Invention

The present invention relates to receiver
down converters and more particularly to receiver down
converters for use in radiotelephones and
5 radiotelephone equipment.

Background of the Invention

With ever increasing demands for increased
talk time and standby time in wireless telephones, the
10 power consumption of each circuit in the telephone can
be critical to the overall performance of the
telephone. Thus, it has become more important to
assure that each circuit uses as little current as
possible to thereby extend battery life of the
15 telephone.

While reducing power usage in the telephone
is important, this goal is generally at odds with other
performance goals for the telephone. For example, as
the number of wireless telephone users utilizing fixed
20 amount of radio spectrum increase, the need to reject
undesired interference can become very important.

However, when operating in strong signal environments higher current is generally required by the down converter of the telephone receiver to compensate for the strong signal environment.

5 In particular in wireless telephone modes such as Code Division Multiple Access (CDMA) mode the linearity of the low noise amplifier, as reflected by the third order intercept point of the amplifier, may be critical to meeting the requirements of CDMA.

10 However, increasing the third order intercept point to increase the linearity of the amplifier generally requires an increase in the current drawn by the amplifier. Thus, the requirements of CDMA may directly conflict with the goal of low power consumption.

15 Previous attempts to address the strong signal condition have included switching off the low noise amplifier of the receiver down converter. When the low noise amplifier is switched off it acts like an attenuator which would increase the signal handling
20 ability of the telephone. Furthermore, since the low noise amplifier is off the power consumed may be reduced. However, such an approach not meet the performance requirements of CDMA.

 Other possible solutions to the strong signal
25 problem may include switching an attenuator in the signal path in the down converter. While this solution may provide a solution to the strong signal problem it would not reduce the power consumption of the down converter.

Similarly, down converter integrated circuits have been developed to accommodate multi-mode wireless telephones. Thus, for example, the RF Micro Devices RF9906 down converter includes adjustable mixer gain
5 which allows for high gain to overcome the higher filter loss of CDMA mode and a low gain for use in AMPS/DAMPS mode. Similarly, the RF9986 device of RF Micro Devices allows for strong signal conditions in CDMA mode by having a switchable third order intercept
10 point which may be increased by 10db by connecting Vcc to the IP3 pin of the device which causes the LNA current consumption to increase by 10 mA. While these devices allow the wireless telephone to meet the various requirements of the modes of operation of the
15 wireless telephone, there continues to be a need to reduce the down converter's power requirements while still meeting the operational requirements of the wireless telephone.

In view of the above discussion, there exists
20 a need for improvement in power management in wireless telephones while still meeting the signal handling requirements of the modes of operation of the wireless telephone.

25

Summary of the Invention

In view of the above discussion, it is an object of the present invention to allow reduced power consumption of a down converter.

A further object of the present invention is to provide a down converter capable of handling strong signal conditions.

Still another object of the present invention is to allow an increase in the battery life of radiotelephones.

Another object of the present invention is to provide a down converter with reduced power consumption in multiple modes of operation of a radiotelephone.

10 These and other objects of the present invention are provided by methods and systems which control the operation of a receiver of a radiotelephone so as to reduce the power consumption of the receiver by setting the third order intercept point of a low noise amplifier based upon at least one of a strength of a signal received by the radiotelephone or a transmission power of a transmitter of the radiotelephone. Furthermore, the gain of the low noise amplifier may also be set based upon the received
15 signal strength or the transmission power of the transmitter of the radiotelephone. Also, the gain of an amplifier associated with a mixer of the receiver of the radiotelephone may be set based upon the strength of the signal received by the radiotelephone or the
20 transmission power of a transmitter of the radiotelephone.

25 By adjusting the third order intercept and/or gain of the low noise amplifier and the gain of the mixer amplifier based on the transmitter power or the
30 received signal strength, the performance of the down

converter may be adjusted to the operating conditions of the telephone. Furthermore, the gains and third order intercept point may be adjusted to reduce the power consumption of the down converter. Thus, as the
5 signal strength increases the performance of the down converter may be maintained while reducing the power required by the down converter. The total power required to operate the radiotelephone may be decreased and battery life correspondingly increased.

10 In certain embodiments of the present invention the gains of the low noise amplifier and mixer amplifier of the down converter may be set by bypassing the amplifiers. Thus, the gains are selected between two gain levels for the amplifiers.

15 In particular embodiments of the present invention, the third order intercept point of the low noise amplifier is set to a low third order intercept point, the gain of the low noise amplifier to a high gain and the gain of the mixer amplifier to a high gain
20 if the transmitter is off.

In alternative embodiments of the present invention in which the radiotelephone is operating in CDMA mode, if the transmitter is operating at an output power above a predefined threshold or the received
25 signal strength is below a predefined threshold, the third order intercept point of the low noise amplifier may be set to a high third order intercept point, the gain of the low noise amplifier set to a high gain and the gain of the mixer amplifier set to a high gain. If
30 the transmitter is operating at an output power below

the predefined threshold or the received signal strength is above a predefined threshold, the third order intercept point of the low noise amplifier may also be set to a high third order intercept point, the gain of the low noise amplifier set to a high gain and the gain of the mixer amplifier set to a low gain. The third order intercept point of the low noise amplifier may also be set to a high third order intercept point, the gain of the low noise amplifier set to a high gain and the gain of the mixer amplifier set to a low gain if the transmitter is operating at an output power below the predefined threshold output power and the received signal strength is greater than a first predefined signal strength threshold and less than a second predefined signal strength threshold. The gain of the low noise amplifier may be set to a low gain and the gain of the mixer amplifier set to a high gain if the transmitter is operating at an output power below the predefined threshold output power and the received signal strength is greater than the second predefined signal strength threshold and less than a third predefined signal strength threshold. Finally, the gain of the low noise amplifier may be set to a low gain and the gain of the mixer amplifier to a low gain if the transmitter is operating at an output power below the predefined threshold output power and the received signal strength is greater than the third predefined signal strength threshold.

By providing several thresholds of power conservation, the present invention may provide the

high linearity required by the CDMA mode of operation while still reducing the total power consumed by the down converter. Thus, the present invention can allow the down converter to meet the performance criteria of
5 CDMA while still conserving power.

In another embodiment of the present invention, the receiver of the radiotelephone is disabled if the radiotelephone is in sleep mode.

In an embodiment of the present invention
10 where the radiotelephone is operating in Advanced Mobile Phone Service/Digital Advanced Mobile Phone Service (AMPS/DAMPS) mode, the third order intercept point of the low noise amplifier may be set to a low
15 third order intercept point, the gain of the low noise amplifier set to a high gain and the gain of the mixer amplifier set to a low gain if the received signal strength is less than a first predefined signal strength threshold. The third order intercept of the
20 low noise amplifier may be set to a low third order intercept point, the gain of the low noise amplifier set to a high gain and the gain of the mixer amplifier set to a low gain if the received signal strength is greater than the first predefined signal strength
25 threshold and less than a second predefined signal strength threshold. The gain of the low noise amplifier may also be set to a low gain and the gain of the mixer amplifier set to a low gain if the received signal strength is greater than the second predefined signal strength threshold.

In still another embodiment of the present invention, the operation of a receiver of a radiotelephone so as to reduce the power consumption of the receiver by determining the received signal strength of a signal received by the radiotelephone and controlling the power consumption of a down converter of the receiver of the radiotelephone based upon the determined received signal strength. This determination may include determining if the received signal strength is above a first threshold value, if the received signal strength is between the first threshold value and a second threshold value and if the received signal strength is above the second threshold value. The gain of the low noise amplifier may then be set to a low gain and the gain of the mixer amplifier to a low gain if the signal strength is above the second threshold value, the gain of a low noise amplifier of the down converter set to a high gain and the gain of a mixer amplifier of the down converter set to a low gain if the received signal strength is between the first threshold value and the second threshold value and the gain of a low noise amplifier of the down converter set to a high gain and the gain of a mixer amplifier of the down converter set to a high gain if the received signal strength is below the first threshold value. In a particular embodiment, the first threshold value is about -94 dBm, and the second threshold value is about -60 dBm.

By controlling the gains of amplifiers in AMPS/DAMPS mode based upon several threshold values the

power consumption of the down converter may be reduced without sacrificing performance.

Brief Description of the Drawings

5 **Figure 1** is a block diagram of a radiotelephone incorporating a down converter of the present invention;

Figure 2 is a block diagram of a down converter according to the present invention; and

10 **Figure 3** is a flow chart illustrating operation of a down converter according to the present invention.

Detailed Description of the Invention

15 The present invention now will be described more fully hereinafter with reference to the accompanying drawings, in which preferred embodiments of the invention are shown. This invention may, however, be embodied in many different forms and should
20 not be construed as limited to the embodiments set forth herein; rather, these embodiments are provided so that this disclosure will be thorough and complete, and will fully convey the scope of the invention to those skilled in the art. Like numbers refer to like
25 elements throughout. As will be appreciated by one of skill in the art, the present invention may be embodied as methods or devices. Accordingly, the present invention may take the form of an entirely hardware
30 embodiment or an embodiment combining software and hardware aspects.

An embodiment of a radiotelephone 10 which includes a down converter 15 according to the present invention is depicted in the block diagram of **Figure 1**. As shown in **Figure 1**, radiotelephone 10 typically includes a transmitter 12, a receiver 14, a user interface 16 and an antenna system 18. The antenna system 18 may include an antenna feed structure 22 and an antenna 20. As is well known to those of skill in the art, transmitter 12 converts the information which is to be transmitted by radiotelephone 10 into an electromagnetic signal suitable for radio communications. Receiver 14 demodulates electromagnetic signals which are received by radiotelephone 10 so as to provide the information contained in the signals to user interface 16 in a format which is understandable to the user. A wide variety of transmitters 12, receivers 14, user interfaces 16 (e.g., microphones, keypads, rotary dials) which are suitable for use with handheld radiotelephones are known to those of skill in the art, and such devices may be implemented in radiotelephone 10. The design of radiotelephone 10 is well known to those of skill in the art and will not be further described herein.

The present invention relates to the down converter 15 incorporated in receiver 14. As seen in **Figure 1**, the radiotelephone 10 includes as part of the receiver 14 a down converter 15. A radiotelephone incorporating the present invention also preferably includes circuitry and programming for measuring the

signal strength received by the radiotelephone. Such circuitry and programming are well known to those of skill in the art and, therefore, will not be described in detail herein. Furthermore, it is preferable that
5 such circuitry also contribute to the control of the output power of the transmitter portion of the radiotelephone. Thus, the output power of the transmitter 12 is preferably controlled, at least in part, by the received signal strength such that when
10 the received signal strength is low the output power of the transmitter 12 is high and when the received signal strength is high the output power of the transmitter 12 is reduced.

In operation, a down converter 15 of the
15 present invention utilizes information about the signal conditions and operational state of the radiotelephone to control the operation of the down converter 15 to reduce power consumption. Such control may be accomplished by selectively changing the linearity of
20 an amplifier or amplifiers by changing the third order intercept of an amplifier or amplifiers in the down converter 15, by adjusting the gain of an amplifier or amplifiers in the down converter 15 or by selectively bypassing portions of the down converter 15. One
25 embodiment of a down converter 15 which allows for such control is illustrated in **Figure 2**.

As seen in **Figure 2**, the down converter 15 preferably includes a low noise amplifier (LNA) 30 which may receive and amplify the incoming signal. A
30 switch 32 allows the LNA 30 to be bypassed. As will be

appreciated by those of skill in the art, any number of switching devices may be utilized to bypass the LNA 30 such as a transistor, relay or other such switching devices known to those of skill in the art. By
5 bypassing the LNA 30, the LNA 30 may be disabled so that it draws no power. Accordingly, bypassing LNA 30 may reduce the total power requirements of the radiotelephone 10.

The output of the LNA 30 or the switch 32 is
10 provided to an interstage filter, such as a band pass filter 34 and the output of the filter 34 provided to a variable gain mixer 46. The variable gain mixer 46 is illustrated as having an amplifier component 38 and a mixer component 40. The amplifier 38 of the variable
15 gain mixer 46 may also be bypassed by a switch 42. By bypassing amplifier 38, the amplifier may be disabled so that it does not add to the power requirements of radiotelephone 10.

Amplifiers 30 and 38 may be variable gain
20 amplifiers and amplifier 30 may have an adjustable third order intercept point. Alternatively, fixed gain amplifiers may be utilized and the amplifier bypassed as described herein to provide two gain settings including a high gain when the amplifier is
25 incorporated in the down converter and a low or no gain when the amplifier is bypassed. Amplifiers which provide an adjustable third order intercept point or variable gain include, for example, the PCS Low Noise Amplifier/Mixer RF9986 and the CDMA/FM Low Noise
30 Amplifier/Mixer RF9906 of RF Micro Devices of

Greensboro, North Carolina. While these devices may allow for variable gain or variable intercept points, there is no indication of how these devices may be intelligently controlled to provide the optimum
5 tradeoff between power consumption and signal handling over the operating range of the radiotelephone 10. By adjusting the gain and third order intercept point the power requirements of the amplifiers may be adjusted. Thus, for example, by decreasing the third order
10 intercept point of LNA 30 the power required by LNA 30 may be reduced, although, the linearity of LNA 30 may also be reduced by reducing the third order intercept point. Similarly, by reducing the gain of the amplifiers 30 and 38 the power required by these
15 amplifiers may be reduced.

While the present invention is described as bypassing amplifiers 30 and 38 with a switch, as will be appreciated by those of skill in the art, other methods of allowing a signal through the amplifier
20 without requiring the amplifier to be active may be utilized while still benefiting from the teachings of the present invention. Furthermore, the present invention is not limited to two amplifier systems but may be utilized in systems having any number of
25 amplifiers including single amplifier systems such as systems without an amplifier 38 in the mixer 46.

The operation of the present invention will now be described with respect to Figure 3 which is a flowchart illustrating the operation of a down
30 converter utilizing the present invention. It will be

understood that each block of the flowchart illustration, and combinations of blocks in the flowchart illustration, can be implemented by computer program instructions. These program instructions may
5 be provided to a processor to produce a machine, such that the instructions which execute on the processor create means for implementing the functions specified in the flowchart block or blocks. The computer program instructions may be executed by a processor to cause a
10 series of operational steps to be performed by the processor to produce a computer implemented process such that the instructions which execute on the processor provide steps for implementing the functions specified in the flowchart block or blocks.

15 Accordingly, blocks of the flowchart illustration support combinations of means for performing the specified functions, combinations of steps for performing the specified functions and program instruction means for performing the specified
20 functions. It will also be understood that each block of the flowchart illustration, and combinations of blocks in the flowchart illustration, can be implemented by special purpose hardware-based systems which perform the specified functions or steps, or
25 combinations of special purpose hardware and computer instructions.

Figure 3 illustrates the operations of a radiotelephone according to the present invention which is capable of operating in either CDMA mode or
30 AMPS/DAMPS mode. As will be appreciated by those of

skill in the art, the present invention may be suitable for use in radiotelephones implementing a single communication mode.

As seen in **Figure 3**, if the radiotelephone 10 is in sleep mode, then the receiver 14, including the down converter 15, is turned off (blocks 50 and 52). If the radiotelephone 10 is not in sleep mode, then it is determined if the radiotelephone is in standby mode (block 54). If the radiotelephone is in standby mode then the LNA 30 is set to a high gain with a low intercept point and the mixer or inter-stage amplifier 38 is not bypassed (block 56). Thus, switch 32 and switch 42 would both be open. This mode of operation may be used to listen to a base station while the transmitter is turned off and is suitable for either CDMA or AMPS/DAMPS mode of operation. In this mode the current required by the down converter 15 is reduced by using a low third order intercept for the LNA 30. Furthermore, while not illustrated in **Figure 3**, if the control channel signal is sufficiently strong, then the down converter 15 may be placed in one of TX-2, TX-3 or TX-4 modes described below.

If the radiotelephone 10 is not in standby mode, then it is determined if the transmitter is transmitting at maximum power (block 58). Alternatively, it could be determined if the received signal strength is below a minimum threshold. If the transmitter is transmitting at maximum power, then it may be determined if the radiotelephone 10 is operating in CDMA mode (block 60). If not, then the

radiotelephone is operating in AMPS/DAMPS mode (AMPS/DAMPS Maximum Gain Mode) and the LNA 30 is set to a high gain with a low intercept point and the mixer or inter-stage amplifier 38 is not bypassed (block 62) as described above with regard to standby mode. If, however, the radiotelephone 10 is in CDMA mode (CDMA TX-1 Mode), then the LNA is set to a high gain and a high intercept point and the mixer amplifier 38 is not bypassed (block 64).

10 If the transmitter is not transmitting at maximum power or the received signal strength is above the minimum threshold, then it is determined if the received signal strength is between -84 and -94 dBm (block 66). If this is the case, then it is determined
15 if the radiotelephone is operating in CDMA mode (block 68). If not, then the radiotelephone is operating in AMPS/DAMPS mode (AMPS/DAMPS Reduced Gain Mode) and the LNA 30 is set to a high gain with a low intercept point and the mixer or inter-stage amplifier 38 is bypassed
20 (block 72). Thus, switch 32 would be open and switch 42 would be closed. This provides a high gain for the LNA 30 and a low gain for the mixer amplifier 38. Because mixer amplifier 38 is bypassed, as described above it may be disabled so that it requires no
25 current. If radiotelephone 10 is in CDMA mode (CDMA TX-2 Mode), the LNA 30 is set to a high gain with a high intercept point and the mixer or inter-stage amplifier 38 is bypassed (block 70) as described above. This mode of operation may be used in full duplex operation
30 with the transmitter in the mid power range.

If the received signal strength is not between -84 and -94 dBm, then it is determined if the received signal strength is between -60 and -84 dBm (block 74). If this is the case, then it is determined
5 if the radiotelephone is operating in CDMA mode (block 76). If not, then the radiotelephone is operating in AMPS/DAMPS mode (AMPS/DAMPS Reduced Gain Mode) and the LNA 30 is set to a high gain with a low intercept point and the mixer or inter-stage amplifier 38 is bypassed
10 (block 72) as described above. If radiotelephone 10 is in CDMA mode (CDMA TX-3 Mode), the LNA 30 is bypassed and the mixer or inter-stage amplifier 38 is active (block 78). Thus, switch 32 would be closed and switch 42 would be open. This provides a low gain for the LNA
15 30 and a high gain for the mixer amplifier 38. Because LNA 30 is bypassed, as described above it may be disabled so that it requires no current. This mode of operation may be used in full duplex operation with the transmitter in the mid to low power range.

20 If the received signal strength is not between -60 and -84 dBm, then it is determined if the received signal strength is greater than -60 dBm (block 80). If this is the case, then in either mode (AMPS/DAMPS Minimum Gain Mode, CDMA TX-4 Mode) both the
25 LNA 30 and the mixer amplifier 38 are bypassed and may be disabled to draw no current. Thus, switch 32 would be closed and switch 42 would be closed. This provides a low gain for the LNA 30 and a low gain for the mixer amplifier 38. This mode of operation may be used to
30 protect the receiver from high signal levels.

As an example of the operation of the present invention in 1900 MHz CDMA mode, Table 1 illustrates the gain, intercept point (IP) and current drawn for each of the six CDMA modes of operation.

5

Table 1 - CDMA 1900 MHz Operation

Mode	LNA IP (dBm)	LNA Gain (dB)	Mixer Gain (dB)	Receiver Sensitivity (dBm)	Receiver IP (dBm)	Current (ma)
Sleep	x	x	x	x	x	0
Standby	+6	14	15	-106.3	-1.6	29.5
TX-1	+12	14	15	-106.0	-1.4	38
TX-2	+12	14	5	-101.8	+7.0	33
TX-3	x	-5	15	-92.9	+16.4	26
TX-4	x	-5	5	-84.2	+21.2	21

As an example of the operation of the present invention in 800 MHz AMPS/DAMPS mode, Table 2 illustrates the gain, intercept point and current required for each of the modes of operation.

10

Table 2 - AMPS/DAMPS 800 MHz Operation

Mode	LNA IP (dBm)	LNA Gain (dB)	Mixer Gain (dB)	Receiver Sensitivity (dBm)	Receiver IP (dBm)	Current (ma)
Sleep	x	x	x	x	x	0
Maximum Gain	+7	14	15	-118.4	-15.7	25.5
Reduced Gain	+7	14	5	-113.7	-5.8	20.5
Minimum Gain	+18	-5	5	-95.9	+12.7	17

As can be seen from Figure 3, because linearity of the LNA 30 is of less concern in AMPS/DAMPS mode, the power savings, and thus the impact

15

on battery life, may be less than achieved in CDMA mode.

As described herein, changes in third order intercept point are described as setting a "high" third order intercept point and a "low" third order intercept point. While these specific values may change from system to system, the present invention should not be limited to any specific set of values. Furthermore, while particular ranges of signal strength are described herein, the present invention should not be construed as limited to those ranges or to the particular number of power levels described herein. The present invention has been described with respect to CDMA and AMPS/DAMPS but should not be limited to such modes. Finally, while the present invention has been described with respect to a radiotelephone, as will be appreciated by those of skill in the art, the present invention may also be suitable for use in other wireless devices such as a Personal Data Assistant (PDA).

In the drawings and specification, there have been disclosed typical preferred embodiments of the invention and, although specific terms are employed, they are used in a generic and descriptive sense only and not for purposes of limitation, the scope of the invention being set forth in the following claims.

THAT WHICH IS CLAIMED IS:

1. A method of controlling the operation of a receiver of a wireless device so as to reduce the power consumption of the receiver, the method comprising:

5 setting the third order intercept point of a low noise amplifier based upon at least one of a strength of a signal received by the wireless device and a transmission power of a transmitter of the wireless device; and

10 setting the gain of the low noise amplifier based upon at least one of a strength of a signal received by the wireless device and a transmission power of a transmitter of the wireless device.

2. A method according to Claim 1, wherein said step of setting the gain of a low noise amplifier comprises the step of selectively bypassing the low noise amplifier.

3. A method according to Claim 1, further comprising the step of setting the gain of an amplifier associated with a mixer of the receiver of the wireless device based upon at least one of a strength of a
5 signal received by the wireless device and a transmission power of a transmitter of the wireless device.

4. A method according to Claim 3, wherein the step of setting the gain of an amplifier associated

with a mixer comprises the step of selectively bypassing the amplifier associated with the mixer.

5. A method according Claim 3, wherein the steps of setting the third order intercept point, setting the gain of the low noise amplifier and setting the gain of the mixer amplifier, comprise the step of:

5 setting the third order intercept point of the low noise amplifier to a low third order intercept point, the gain of the low noise amplifier to a high gain and the gain of the mixer amplifier to a high gain if the transmitter is off.

6. A method according Claim 3, wherein the steps of setting the third order intercept point, setting the gain of the low noise amplifier and setting the gain of the mixer amplifier, comprise the step of:

5 setting the third order intercept point of the low noise amplifier to a high third order intercept point, the gain of the low noise amplifier to a high gain and the gain of the mixer amplifier to a high gain if wireless device is operating in a CDMA mode and the
10 transmitter is operating at an output power above a predefined threshold output power.

7. A method according Claim 6, wherein the steps of setting the third order intercept point, setting the gain of the low noise amplifier and setting the gain of the mixer amplifier, further comprise the

5 step of:

 setting the third order intercept point of the low noise amplifier to a high third order intercept

point, the gain of the low noise amplifier to a high gain and the gain of the mixer amplifier to a low gain
10 if wireless device is operating in a CDMA mode and the transmitter is operating at an output power below the predefined threshold output power.

8. A method according Claim 6, wherein the steps of setting the third order intercept point, setting the gain of the low noise amplifier and setting the gain of the mixer amplifier, further comprise the
5 steps of:

setting the third order intercept point of the low noise amplifier to a high third order intercept point, the gain of the low noise amplifier to a high gain and the gain of the mixer amplifier to a low gain
10 if wireless device is operating in a CDMA mode, the transmitter is operating at an output power below the predefined threshold output power and the received signal strength is greater than a first predefined signal strength threshold and less than a second
15 predefined signal strength threshold; and

setting the gain of the low noise amplifier to a low gain and the gain of the mixer amplifier to a high gain if wireless device is operating in a CDMA mode, the transmitter is operating at an output power
20 below the predefined threshold output power and the received signal strength is greater than the second predefined signal strength threshold and less than a third predefined signal strength threshold.

9. A method according Claim 8, wherein the steps of setting the third order intercept point,

setting the gain of the low noise amplifier and setting
the gain of the mixer amplifier, further comprise the
5 step of:

setting the gain of the low noise amplifier
to a low gain and the gain of the mixer amplifier to a
low gain if the wireless device is operating in a CDMA
mode, the transmitter is operating at an output power
10 below the predefined threshold output power and the
received signal strength is greater than the third
predefined signal strength threshold.

10. A method according to Claim 3, further
comprising the steps of:

determining if the wireless device is in a
sleep mode; and
5 disabling the receiver if the wireless device
is in sleep mode.

11. A method according Claim 3, wherein the
steps of setting the third order intercept point,
setting the gain of the low noise amplifier and setting
the gain of the mixer amplifier, comprise the step of:

5 setting the third order intercept point of
the low noise amplifier to a low third order intercept
point, the gain of the low noise amplifier to a high
gain and the gain of the mixer amplifier to a low gain
if wireless device is operating in a AMPS/DAMPS mode
10 and the received signal strength is greater than a
first predefined signal strength threshold and less
than a second predefined signal strength threshold; and

setting the gain of the low noise amplifier
to a low gain and the gain of the mixer amplifier to a

15 low gain if wireless device is operating in a
AMPS/DAMPS mode and the received signal strength is
greater than the second predefined signal strength
threshold.

12. A method of controlling the operation of
a receiver so as to reduce the power consumption of the
receiver, the method comprising:

determining a received signal strength of a
5 signal received by the wireless device; and

controlling the power consumption of a down
converter of the receiver of the wireless device based
upon the determined received signal strength.

13. A method according to Claim 12, wherein
said step of determining comprises the steps of:

determining if the received signal strength
is below a first threshold value;

5 determining if the received signal strength
is between the first threshold value and a second
threshold value; and

determining if the received signal strength
is above the second threshold value.

14. A method according to Claim 13, wherein
said controlling step comprises:

setting the gain of the low noise amplifier
to a low gain and the gain of the mixer amplifier to a
5 low gain if the signal strength is above the second
threshold value;

setting the gain of a low noise amplifier of
the down converter to a high gain and the gain of a

10 mixer amplifier of the down converter to a low gain if
the received signal strength is between the first
threshold value and the second threshold value; and
setting the gain of a low noise amplifier of
the down converter to a high gain and the gain of a
mixer amplifier of the down converter to a high gain if
15 the received signal strength is below the first
threshold value.

15. A method according to Claim 14, wherein
the first threshold value is about -94 dBm, and the
second threshold value is about -60 dBm.

16. A down converter for a receiver of a
wireless device, comprising:
a low noise amplifier;
means for setting the third order intercept
5 point of the low noise amplifier based upon at least
one of a strength of a signal received by the wireless
device and a transmission power of a transmitter of the
wireless device; and
means for setting the gain of the low noise
10 amplifier based upon at least one of a strength of a
signal received by the wireless device and a
transmission power of a transmitter of the wireless
device.

17. A down converter according to Claim 16,
wherein said means for setting the gain of the low
noise amplifier comprises means for selectively
bypassing the low noise amplifier.

18. A down converter according to Claim 17, wherein said means for bypassing comprises a switch.

19. A down converter according to Claim 16, further comprising:

an amplifier associated with a mixer of the receiver;

5 means for setting the gain of the amplifier associated with a mixer of the receiver of the wireless device based upon at least one of a strength of a signal received by the wireless device and a transmission power of a transmitter of the wireless
10 device.

20. A system according to Claim 19, wherein said means for setting the gain of an amplifier associated with the mixer comprises means for selectively bypassing the amplifier associated with the
5 mixer.

21. A down converter according to Claim 20, wherein said means for bypassing the amplifier associated with the mixer comprises a switch.

22. A down converter according Claim 19, wherein said means for setting the third order intercept point, means for setting the gain of the low noise amplifier and means for setting the gain of the
5 mixer amplifier, comprise:

means for setting the third order intercept point of the low noise amplifier to a low third order intercept point, the gain of the low noise amplifier to

a high gain and the gain of the mixer amplifier to a
10 high gain if the transmitter is off.

23. A down converter according Claim 19,
wherein said means for setting the third order
intercept point, means for setting the gain of the low
noise amplifier and means for setting the gain of the
5 mixer amplifier, comprise:

means for setting the third order intercept
point of the low noise amplifier to a high third order
intercept point, the gain of the low noise amplifier to
a high gain and the gain of the mixer amplifier to a
10 high gain if wireless device is operating in a CDMA
mode and the transmitter is operating at an output
power above a predefined threshold output power.

24. A down converter according Claim 23,
wherein said means for setting the third order
intercept point, means for setting the gain of the low
noise amplifier and means for setting the gain of the
5 mixer amplifier, further comprise:

means for setting the third order intercept
point of the low noise amplifier to a high third order
intercept point, the gain of the low noise amplifier to
a high gain and the gain of the mixer amplifier to a
10 low gain if wireless device is operating in a CDMA mode
and the transmitter is operating at an output power
below the predefined threshold output power.

25. A down converter according Claim 23,
wherein said means for setting the third order
intercept point, means for setting the gain of the low

noise amplifier and means for setting the gain of the
5 mixer amplifier, further comprise:

means for setting the third order intercept
point of the low noise amplifier to a high third order
intercept point, the gain of the low noise amplifier to
a high gain and the gain of the mixer amplifier to a
10 low gain if wireless device is operating in a CDMA
mode, the transmitter is operating at an output power
below the predefined threshold output power and the
received signal strength is greater than a first
predefined signal strength threshold and less than a
15 second predefined signal strength threshold; and

means for setting the gain of the low noise
amplifier to a low gain and the gain of the mixer
amplifier to a high gain if wireless device is
operating in a CDMA mode, the transmitter is operating
20 at an output power below the predefined threshold
output power and the received signal strength is
greater than the second predefined signal strength
threshold and less than a third predefined signal
strength threshold.

26. A down converter according Claim 25,
wherein said means for setting the third order
intercept point, means for setting the gain of the low
noise amplifier and means for setting the gain of the
5 mixer amplifier, further comprise:

means for setting the gain of the low noise
amplifier to a low gain and the gain of the mixer
amplifier to a low gain if wireless device is operating
in a CDMA mode, the transmitter is operating at an
10 output power below the predefined threshold output

power and the received signal strength is greater than the third predefined signal strength threshold.

27. A down converter according to Claim 19, further comprising:

means for determining if the wireless device is in a sleep mode; and

5 means for disabling the receiver if the wireless device is in sleep mode.

28. A down converter according Claim 19, wherein said means for setting the third order intercept point, means for setting the gain of the low noise amplifier and means for setting the gain of the mixer amplifier, comprise:

means for setting the third order intercept point of the low noise amplifier to a low third order intercept point, the gain of the low noise amplifier to a high gain and the gain of the mixer amplifier to a low gain if wireless device is operating in a AMPS/DAMPS mode and the received signal strength is greater than a first predefined signal strength threshold and less than a second predefined signal strength threshold; and

15 means for setting the gain of the low noise amplifier to a low gain and the gain of the mixer amplifier to a low gain if wireless device is operating in a AMPS/DAMPS mode and the received signal strength is greater than the second predefined signal strength threshold.

20

29. A down converter according to Claim 16, wherein the wireless device is a radiotelephone.

30. A down converter for a receiver of a wireless device, comprising:

means for determining a received signal strength of a signal received by the wireless device;

5 and

means for controlling the power consumption of a down converter of the receiver of the wireless device based upon the determined received signal strength.

31. A down converter according to Claim 30, wherein said means for determining comprises:

means for determining if the received signal strength is below a first threshold value;

5 means for determining if the received signal strength is between the first threshold value and a second threshold value; and

means for determining if the received signal strength is above the second threshold value.

32. A down converter according to Claim 31, wherein said means for controlling comprises:

means for setting the gain of the low noise amplifier to a low gain and the gain of the mixer amplifier to a low gain if the signal strength is above the second threshold value;

5 means for setting the gain of a low noise amplifier of the down converter to a high gain and the gain of a mixer amplifier of the down converter to a

10 low gain if the received signal strength is between the
first threshold value and the second threshold value;
and

means for setting the gain of a low noise
amplifier of the down converter to a high gain and the
15 gain of a mixer amplifier of the down converter to a
high gain if the received signal strength is below the
first threshold value.

33. A down converter according to Claim 32,
wherein the first threshold value is about -94 dBm, and
the second threshold value is about -60 dBm.

34. A down converter according to Claim 30,
wherein the wireless device is a radiotelephone.

35. A radiotelephone, comprising:
a transmitter circuit;
a user interface circuit;
an antenna system;
5 a receiver circuit including a down converter
wherein the down converter of a receiver of the
radiotelephone comprises:

a low noise amplifier;
means for setting the third order intercept
10 point of the low noise amplifier based upon at least
one of a strength of a signal received by the wireless
device and a transmission power of the transmitter; and
means for setting the gain of the low noise
amplifier based upon at least one of a strength of a
15 signal received by the wireless device and a
transmission power of the transmitter.

36. A radiotelephone, comprising:
a transmitter circuit;
a user interface circuit;
an antenna system;
5 a receiver circuit having a down converter
wherein the down converter of the receiver of the
radiotelephone comprises:
means for determining a received signal
strength of a signal received by the wireless device;
10 and
means for controlling the power consumption
of a down converter of the receiver of the wireless
device based upon the determined received signal
strength.

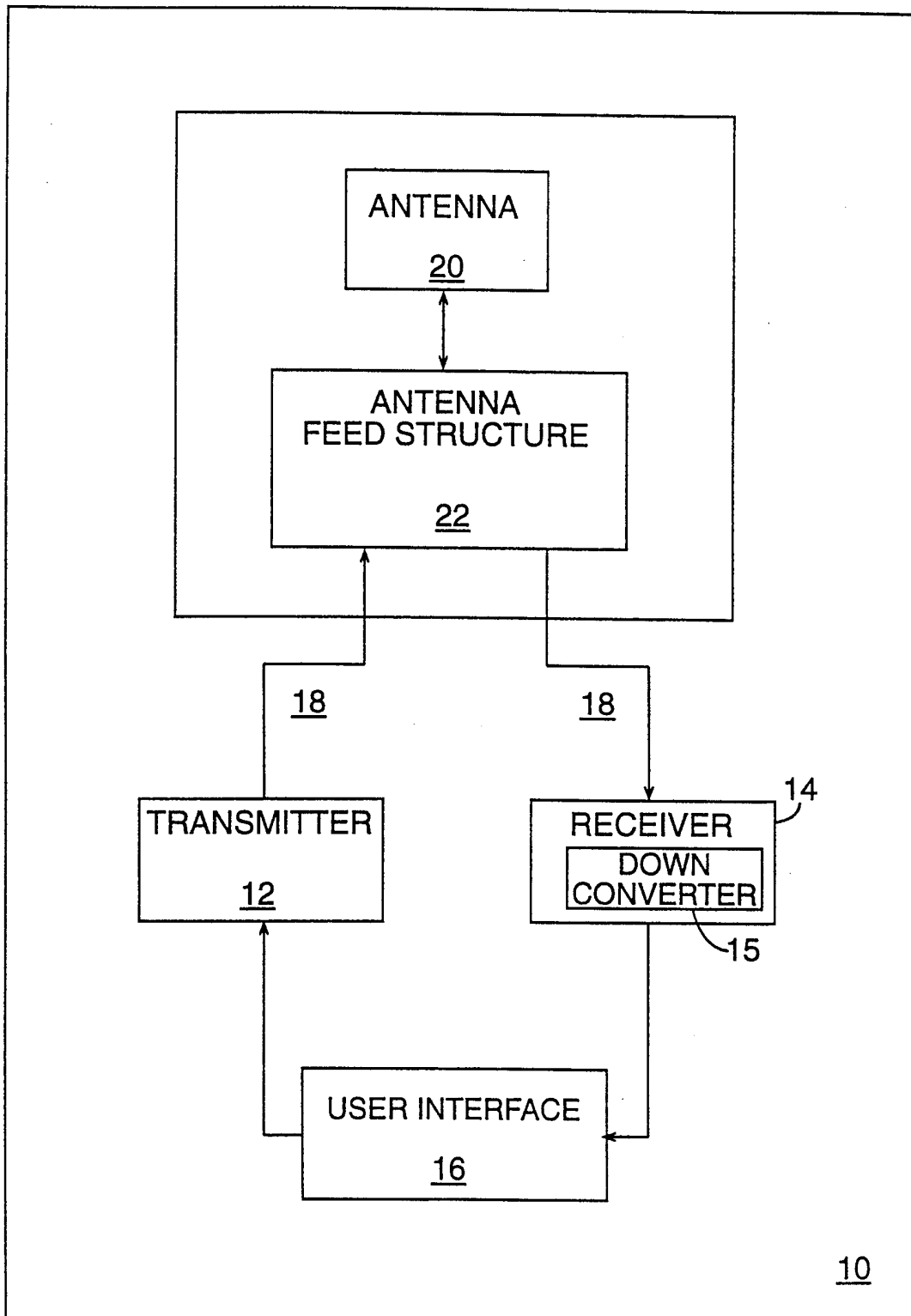

FIGURE 1

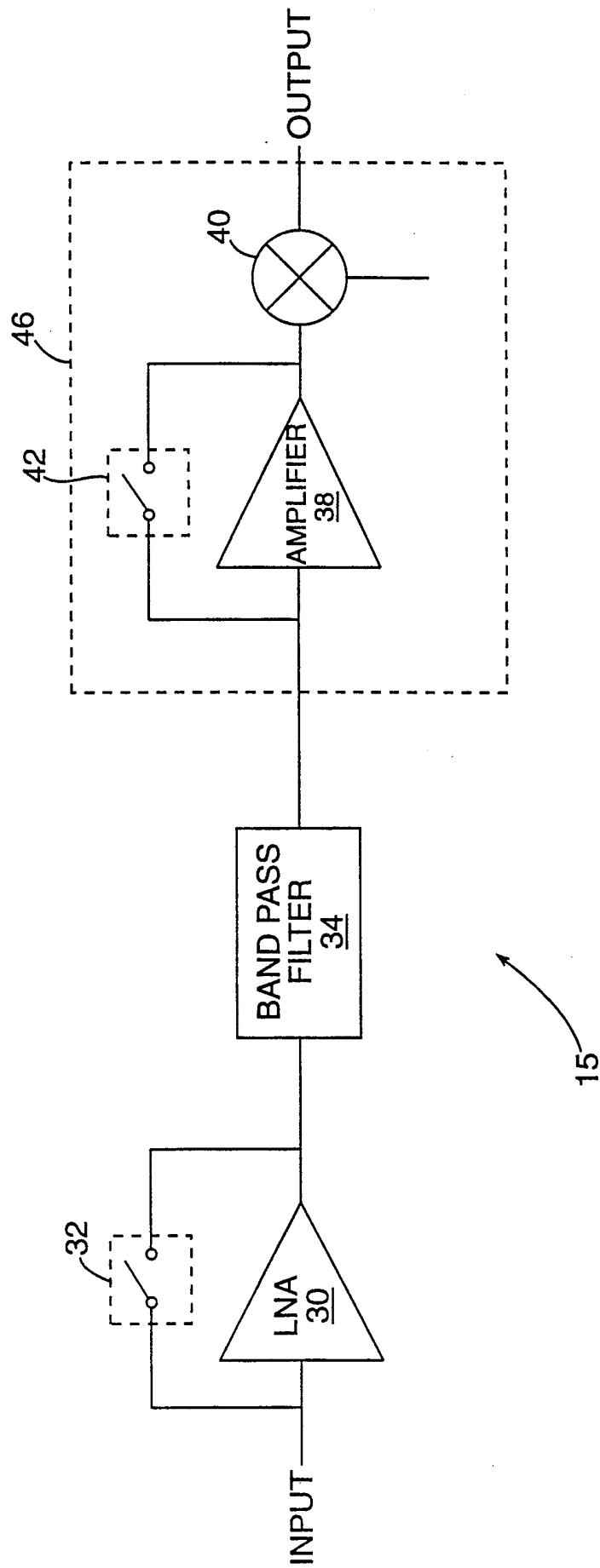

FIGURE 2

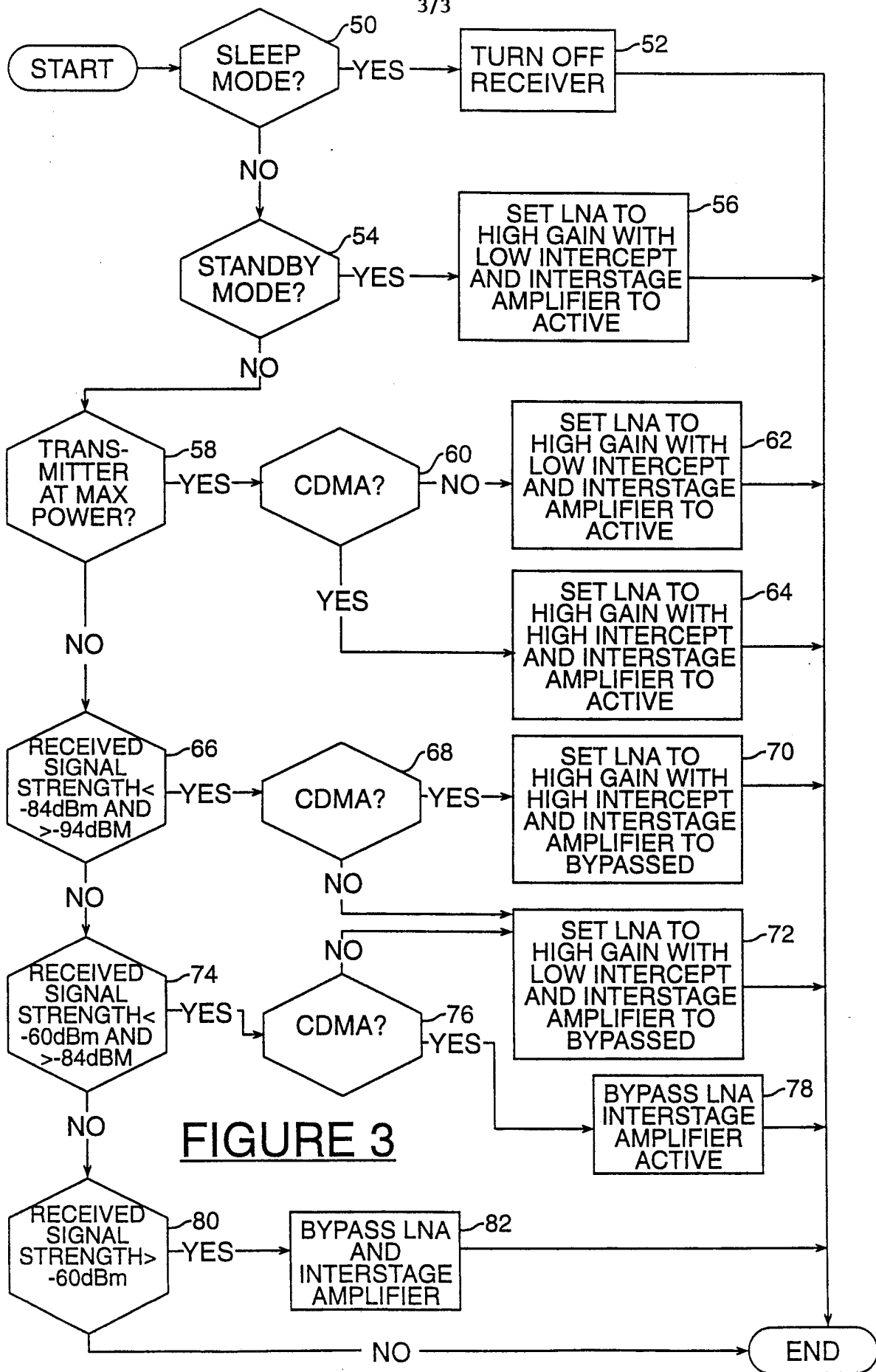

FIGURE 3

INTERNATIONAL SEARCH REPORT

International Application No

PCT/US 99/14433

A. CLASSIFICATION OF SUBJECT MATTER IPC 7 H03G3/30 H03G1/00		
According to International Patent Classification (IPC) or to both national classification and IPC		
B. FIELDS SEARCHED		
Minimum documentation searched (classification system followed by classification symbols) IPC 7 H03G H04Q		
Documentation searched other than minimum documentation to the extent that such documents are included in the fields searched		
Electronic data base consulted during the international search (name of data base and, where practical, search terms used)		
C. DOCUMENTS CONSIDERED TO BE RELEVANT		
Category °	Citation of document, with indication, where appropriate, of the relevant passages	Relevant to claim No.
X	US 5 722 061 A (WIECK CHRIS P ET AL) 24 February 1998 (1998-02-24) column 3, line 52 -column 4, line 3 column 7, line 9 - line 18 column 8, line 5 - line 12 ---	1, 12, 30, 36
X	WO 97 41643 A (JOHNSON TORBJOERN ;MALMGREN JENS (SE); RADIO DESIGN INNOVATION AB) 6 November 1997 (1997-11-06) the whole document ---	1, 12, 30, 36
A	US 5 778 026 A (ZAK ROBERT ALLEN) 7 July 1998 (1998-07-07) abstract ---	1
A	US 5 054 052 A (NONAMI TAKAYUKI) 1 October 1991 (1991-10-01) abstract -----	1, 12, 30, 36
<input type="checkbox"/> Further documents are listed in the continuation of box C.		
<input checked="" type="checkbox"/> Patent family members are listed in annex.		
° Special categories of cited documents :		
"A" document defining the general state of the art which is not considered to be of particular relevance "E" earlier document but published on or after the international filing date "L" document which may throw doubts on priority claim(s) or which is cited to establish the publication date of another citation or other special reason (as specified) "O" document referring to an oral disclosure, use, exhibition or other means "P" document published prior to the international filing date but later than the priority date claimed	"T" later document published after the international filing date or priority date and not in conflict with the application but cited to understand the principle or theory underlying the invention "X" document of particular relevance; the claimed invention cannot be considered novel or cannot be considered to involve an inventive step when the document is taken alone "Y" document of particular relevance; the claimed invention cannot be considered to involve an inventive step when the document is combined with one or more other such documents, such combination being obvious to a person skilled in the art. "&" document member of the same patent family	
Date of the actual completion of the international search <p style="text-align: center; font-size: 1.2em;">1 October 1999</p>	Date of mailing of the international search report <p style="text-align: center; font-size: 1.2em;">08/10/1999</p>	
Name and mailing address of the ISA European Patent Office, P.B. 5818 Patentlaan 2 NL - 2280 HV Rijswijk Tel. (+31-70) 340-2040, Tx. 31 651 epo nl, Fax: (+31-70) 340-3016	Authorized officer <p style="text-align: center; font-size: 1.2em;">Blaas, D-L</p>	

INTERNATIONAL SEARCH REPORT

Information on patent family members

International Application No

PCT/US 99/14433

Patent document cited in search report	A	Publication date	Patent family member(s)	Publication date
US 5722061	A	24-02-1998	US 5732341 A	24-03-1998
			US 5722063 A	24-02-1998
			FI 990710 A	30-03-1999
			NO 991578 A	28-05-1999
			WO 9929047 A	10-06-1999
			AU 1424799 A	01-04-1999
			AU 1424899 A	01-04-1999
			AU 1424999 A	01-04-1999
			AU 1425099 A	22-04-1999
			AU 703393 B	25-03-1999
			AU 4419696 A	03-07-1996
			BR 9510050 A	03-11-1998
			CA 2207745 A	20-06-1996
			CN 1175329 A	04-03-1998
			EP 0797873 A	01-10-1997
			FI 972501 A	15-08-1997
			JP 10510965 T	20-10-1998
			WO 9619048 A	20-06-1998
US 5930692 A	27-07-1999			
ZA 9510321 A	19-06-1996			
WO 9741643	A	06-11-1997	AU 2314097 A	19-11-1997
			SE 9601620 A	30-10-1997
US 5778026	A	07-07-1998	AU 706197 B	10-06-1999
			AU 5560796 A	07-11-1996
			BR 9608025 A	04-05-1999
			CA 2218684 A	24-10-1996
			EP 0823183 A	11-02-1998
			NO 974833 A	17-12-1997
			NZ 306912 A	28-05-1999
			WO 9633585 A	24-10-1996
US 5054052	A	01-10-1991	JP 2262730 A	25-10-1990
			JP 7073385 B	02-08-1995
			GB 2230162 A, B	10-10-1990
			GB 2267797 A, B	15-12-1993
			GB 2271914 A, B	27-04-1994
			GB 2271915 A, B	27-04-1994
			US RE36056 E	19-01-1999