

(19) World Intellectual Property
Organization
International Bureau



(43) International Publication Date
13 May 2004 (13.05.2004)

PCT

(10) International Publication Number
WO 2004/039907 A1

- (51) International Patent Classification⁷: **C09J 123/14**
- (21) International Application Number:
PCT/US2003/033860
- (22) International Filing Date: 27 October 2003 (27.10.2003)
- (25) Filing Language: English
- (26) Publication Language: English
- (30) Priority Data:
10/282,168 28 October 2002 (28.10.2002) US
- (71) Applicant: **BOSTIK FINDLEY, INC.** [US/US]; 11320 Watertown Plank Road, Wauwatosa, WI 53226 (US).
- (72) Inventors: **KANDERSKI, Monina, Dadap**; 2508 West Edgerton Avenue, Milwaukee, WI 53221 (US). **SVEN-NINGSEN, Lacreitia, A.**; W213 S7767 Annes Way, Muskego, WI 53150 (US). **STRELOW, Diane, M.**; 2529 N. 94th Street, Wauwatosa, WI 53226 (US). **ZHANG, Chongyao**; 4045 N. Prospect Avenue, Shorewood, WI 53211 (US). **GIBES, Mark, A.**; 1724 Laura Lane, Port Washington, WI 53074 (US). **WANG, Baoyu**; W226 N2818 Foxwood Lane, Waukesha, WI 53186 (US).
- (74) Agents: **WOZNY, Thomas, M.** et al.; Andrus, Sceales, Starke & Sawall, 100 East Wisconsin Avenue, Suite 1100, Milwaukee, WI 53202 (US).
- (81) Designated States (*national*): AE, AG, AL, AM, AT, AU, AZ, BA, BB, BG, BR, BY, BZ, CA, CH, CN, CO, CR, CU, CZ, DE, DK, DM, DZ, EC, EE, ES, FI, GB, GD, GE, GH, GM, HR, HU, ID, IL, IN, IS, JP, KE, KG, KP, KR, KZ, LC, LK, LR, LS, LT, LU, LV, MA, MD, MG, MK, MN, MW, MX, MZ, NO, NZ, OM, PH, PL, PT, RO, RU, SC, SD, SE, SG, SK, SL, TJ, TM, TN, TR, TT, TZ, UA, UG, UZ, VC, VN, YU, ZA, ZM, ZW.
- (84) Designated States (*regional*): ARIPO patent (GH, GM, KE, LS, MW, MZ, SD, SL, SZ, TZ, UG, ZM, ZW), Eurasian patent (AM, AZ, BY, KG, KZ, MD, RU, TJ, TM), European patent (AT, BE, BG, CH, CY, CZ, DE, DK, EE, ES, FI, FR, GB, GR, HU, IE, IT, LU, MC, NL, PT, RO, SE, SI, SK, TR), OAPI patent (BF, BJ, CF, CG, CI, CM, GA, GN, GQ, GW, ML, MR, NE, SN, TD, TG).
- Published:**
— with international search report
— before the expiration of the time limit for amending the claims and to be republished in the event of receipt of amendments
- For two-letter codes and other abbreviations, refer to the "Guidance Notes on Codes and Abbreviations" appearing at the beginning of each regular issue of the PCT Gazette.*

(54) Title: HOT MELT ADHESIVE COMPOSITION BASED ON A RANDOM COPOLYMER OF ISOTACTIC POLYPROPYLENE AND A SECONDARY POLYMER

(57) Abstract: A hot melt adhesive composition is based on an isotactic polypropylene random copolymer (RCP). The composition contains about 4 % - 50 % by weight of the RCP copolymer, about 20 % - 65 % by weight of a compatible tackifier, about 0 % - 40 % by weight of a plasticizer, about 0 % - 3 % by weight of a stabilizer, about 0 % - 40 % by weight of a wax, about 0 % - 60 % by weight of an atactic poly- α -olefin (APAO), and about 0 % - 40 % by weight of a secondary polymer. The adhesive composition may be used in a number of applications such as, for example, in disposable nonwoven hygienic articles, paper converting, flexible packaging, wood working, carton and case sealing, labeling and other assembly applications.

WO 2004/039907 A1

HOT MELT ADHESIVE COMPOSITION BASED ON A RANDOM
COPOLYMER OF ISOTACTIC POLYPROPYLENE AND A SECONDARY
POLYMER

5

FIELD OF THE INVENTION

This invention relates to novel hot melt adhesive compositions based on stereospecific, predominately semi-crystalline isotactic polypropylene random copolymers (RCP). More particularly, this invention relates to adhesive compositions that find utility in case/carton sealing and in manufacturing nonwoven disposable articles such as diapers and feminine hygiene products. The adhesive compositions are particularly useful as an elastic attachment and construction adhesive in assembly of disposable nonwoven articles.

15

BACKGROUND OF THE INVENTION

Hot melt adhesives typically exist as solid masses at ambient temperature and can be converted to a flowable liquid by the application of heat. These adhesives are particularly useful in manufacturing a variety of disposable goods where bonding of various substrates is often necessary. Specific applications include disposable diapers, hospital pads, feminine sanitary napkins, pantyshields, surgical drapes and adult incontinent briefs, collectively known as disposable nonwoven products. Other diversified applications have involved paper products, packaging materials, tapes and labels. In most of these applications, the hot melt adhesive is heated to its molten state and then applied to a substrate. A second substrate is immediately brought into contact with and compressed against the first. The adhesive solidifies on cooling to form a strong bond. The major advantage of hot melt adhesives is the absence of a liquid carrier, as would be the case of water or solvent based adhesives, thereby eliminating the costly process associated with solvent removal.

For many applications, hot melt adhesives are often extruded directly onto a substrate in the form of a thin film by using piston or gear pump equipment. In this case, the substrate is brought into intimate contact with a hot die under pressure. The temperature of the die must be maintained well above the melting point of the adhesive, which is typically between 150 and 200 °C. For some applications, particularly for manufacturing nonwoven articles, bonding of delicate and heat sensitive substrates, such as thin gauge polyethylene films, is often involved. Direct contact between the film and the die, in these cases, must be avoided to prevent the film from burning or distorting. Several application methods have been developed through which a hot melt adhesive can be spray coated with the aid of compressed air onto a substrate from a distance. These non-contact coating techniques include spiral spray and various forms of melt-blown methods. Direct contact between the coating head and the substrate is thus eliminated. All the coating techniques herein described above are well known to those skilled in the art and commercial equipment is readily available.

The spray coating techniques, however, pose stringent requirements on hot melt adhesives. The viscosity of the adhesives must be sufficiently low, usually in the range of 2,000 to 30,000 cP, preferably in the range of 2,000 to 15,000 cP, at the application temperature. Many other physical factors, especially the rheological properties of the adhesive, come into play in determining the sprayability of a hot melt. The majority of commercial hot melt products do not lend themselves to spray applications. There are no accepted theoretical models or guidelines to predict sprayability and it must be determined empirically with application equipment.

Syndiotactic polypropylene (SPP) polymers are known in this art. The SPP polymers are essentially high molecular weight stereospecific propylene homopolymers or copolymers of propylene with other α -olefin monomers such as ethylene, butene-1 or hexene-1. The syndiotactic polymers should not be confused with the conventional crystalline polypropylenes and essentially amorphous atactic poly- α -olefins (APAO). These polymers differ from each other in both structures

and properties. It is well known to those skilled in the art that the conventional crystalline polypropylenes have an isotactic molecular chain configuration. The isotactic configuration can be described as having the methyl groups attached to the tertiary carbon atoms of successive monomeric units on the same side of a hypothetical plane drawn through the main polymer chain. This type of stereochemistry structure can be illustrated graphically by using the Fisher projection formula as the follow:



Due to its high degree of chain regularity, the conventional isotactic polypropylenes (IPP) are highly crystalline with crystallinity typically greater than 50% and a heat of fusion greater than 70J/g. They are usually stiff materials having high density and high melting point. Due to the lack of flexibility, an IPP polymer can only be used as a modifier in small amounts, typically around 2% to 5% by weight, in hot melt adhesive formulations. A typical conventional IPP usually has a melt flow rate, which is inversely related to the weight average molecular weight, in the range of 0.5 to 200 g/10 min as measured in accordance with ASTM D-1238 test method.

Another component known to be used in a hot melt adhesive composition blend comprises an APAO polymer. APAO polymers are a family of essentially amorphous low molecular weight homopolymers of propylene or copolymers of propylene with ethylene or butene or hexene. In contrast to the regular structures in IPP or SPP, APAOs have atactic molecular chains with the methyl groups on the successive monomeric units sterically randomly distributed on both sides of the hypothetical plane through the polymer chain. The stereo configuration of the atactic APAO molecular chain can be illustrated graphically by using the following Fisher projection formula:

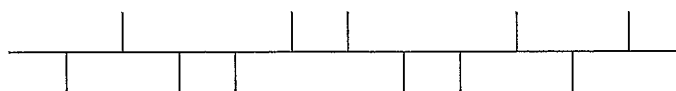

The stereo chain structure of SPP is uniquely different from that of IPP and from that of APAO. In contrast to the isotactic chain configuration of IPP and the

atactic chain configuration of APAO, the stereochemistry of SPP can be described as having the tertiary methyl groups of successive monomer units along the chain alternatively disposed on each side of the hypothetical plane. The stereo configuration of SPP can be depicted below:

5

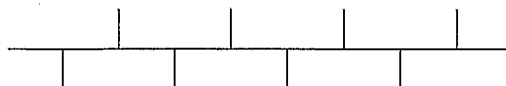

The stereo configuration of polypropylene can also be characterized quantitatively through C-13 NMR. In NMR nomenclature, a “meso” dyad of successive methyl groups on the same side of the plane, as in the case of IPP, is represented by the letter m. A “racemic” dyad of successive methyl groups on the opposite sides of the plane, as in the case of SPP, is represented by the letter r. The percentage of m or r defines the degree of polymer tacticity with the sum of m and r equal to 100%. Thus, a perfect isotactic polypropylene will have 100% m dyad, whereas a perfect syndiotactic polypropylene will have 100% r dyad. This unique stereochemical structure of SPP results in an unusual and desirable combination of physical and mechanical properties such as low density, low melting point, flexibility and toughness. SPP polymers typically have an r value equal to or greater than 70% while the r values of conventional IPPs, in comparison, are generally in a few percent range.

In addition to the difference in stereochemistry, SPPs are also readily distinguishable from IPPs and APAOs by their unique physical properties. Typical SPPs will have a melting point between 130 to 160 °C, whereas crystalline IPPs typically have a melting point about 176 °C. APAOs, on the other hand, are usually predominately amorphous without a well-defined melting point although some grades of commercial products may exhibit very low degree of crystallinity. Another profound difference between SPP and IPP and APAO lies in their densities. The density of SPP is typically between 0.86 to 0.90 g/cm³, which is in between those of IPP and APAO. IPPs have the highest density ranging from 0.90 to 0.95 g/cm³ and APAOs, the lowest ranging from 0.85 to 0.87 g/cm³.

Due to their high melting point, high degree of crystallinity and the lack of desirable physical and mechanical attributes such as flexibility and toughness, the conventional IPPs have not been used alone as the polymer base for hot melt adhesive applications. A hot melt adhesive based on IPP would be too brittle to offer acceptable bond strength and yet would require high application temperature that goes well beyond the melting point of the polymer.

Hot melt adhesives containing APAOs, APAO/polyethylene (PE) blends, APAO/polybutene (PB) blends, or APAO/IPP blends are known in the art. These adhesives typically consist of an APAO, or an APAO blend herein mentioned above, and a hydrocarbon type of tackifier. It is well known that adhesives based on APAOs generally have poor cohesive strength, poor heat resistance, low elevated temperature bond strength and low shear values. APAOs have not found much use in disposable nonwovens applications where a combination of high bond strength at very low coating weight and easy processibility by spray techniques is required. The APAO based adhesives usually lack such capabilities. Although various attempts were made to address these problems by blending APAO with PE, PB and the conventional IPP, very often such modifications not only failed to rectify the problems, but also led to adverse side effects.

For example, Trotter et al, in U.S. Patent No. 4,022,728, describes a hot melt pressure sensitive composition comprising a mixture of APAOs, a low molecular weight substantially amorphous elastomer, a liquid tackifier and a conventional crystalline polypropylene (IPP) in the amount of up to 2% by weight. It is claimed that the composition provides good adhesive properties at low temperatures.

Meyer et al, in U.S. Patent 4,120,916, discloses hot melt adhesive compositions comprising a blend of low molecular weight polyethylene, low molecular weight conventional propylene containing polymer and APAO. These adhesive compositions are said to offer short open time and to be useful for bonding of paraffin modified corrugated board.

Lakshmanan et al, in U.S. Patent No. 4,761,450, discloses a polymer blend useful as hot melt adhesive comprising a low density ethylene polymer, a

copolymer of butene-1 with ethylene or propylene, a hydrocarbon tackifier and a low molecular weight polymer consisting of a low molecular weight liquid polybutene, an amorphous polypropylene and mixtures thereof.

Lakshmanan et al, in U.S. Patent No. 5,478,891, also discloses blend
5 compositions containing (a) a high molecular weight copolymer of ethylene with an α -olefin having at least 4 carbons and (b) an amorphous polypropylene or amorphous polyolefin. The components of the blends are described as having molecular weight range between 300 to 6000. The polymer blends are claimed to be useful for hot melt adhesives, coatings, sealants, asphalt modifiers and plastic
10 additives.

Ryan discloses in U.S. Patent No. 5,747,573 an APAO based hot melt adhesive composition useful for bonding plastics and metallized foil containers. The adhesive composition contains a blend of APAO, a solid benzoate plasticizer and a hydrocarbon tackifier.

15 Sustic, in U.S. Patent No. 5,723,546, discloses a polymer blend consisting of a high molecular weight average, predominantly atactic flexible polyolefin polymer and a low molecular weight average APAO. The blend is said to be useful for hot melt adhesives.

Blending APAO with PE, PB or the conventional IPP leads to several
20 drawbacks. The prior art adhesives containing APAO/PE or APAO/PB blends, such as, for example, those described herein above in U.S. Patents 4,120,916, 4,761,450, and 5,478,891, tend to have poor compatibility. These adhesives can undergo phase separation during application process at which the hot melt adhesives have to be kept in the molten state at high temperature for a prolonged period of time,
25 sometimes for hours or even days. Charring, skinning and gelling can develop rather quickly in the phase separated hot melt adhesives, thereby causing the application equipment to block or plug-up. The incompatibility of such polymer blends also imparts brittleness, optical haziness, poor or no open time, and low bond strength. Although APAO and the conventional IPP blend based hot melts do
30 not have the compatibility problems, they still suffer from all the other drawbacks

herein described above. Moreover, due to high crystallinity and high melting point of the conventional IPP polymers, hot melt adhesives based on APAO/IPP blends tend to be hard and brittle unless the IPP polymer amount is kept at a very low level, such as, for example, at about or below 2% by weight as disclosed in the
5 prior art U.S. Patent 4,022,728. As a result, these adhesives will have poor tensile strength, poor bond strength and poor impact resistance. Another detrimental effect of IPP is the increased coating temperature. The adhesive must be heated above the melting point of IPP (ranging from 180 to 200 °C) for it to reach a liquid state. The blend of high and low molecular weight atactic polyolefin approach described in
10 U.S. Patent 5,723,546, although offering some improvement on tensile properties of APAO, has not been able to provide sufficient tensile strength and high temperature properties to overcome the deficiencies of sole APAO based hot melts.

In a prior U.S. Patent 5,317,070, Brant et al disclosed a hot melt adhesive based on tackified SPP having a polymer chain of at least 80% racemic dyads and
15 having a melting point of about 100 to 180 °C. The adhesive is claimed to have good open times between the application of the adhesive and the formation of the joint. This type of tackified SPP usually lacks flexibility and toughness, and therefore, will also have poor bond strength and poor impact resistance. Furthermore, SPP exhibits an inherent shrinkage problem when it transforms from
20 liquid to solid crystalline state. The shrinkage often causes stress concentration at adhesive/substrate interfaces, and consequently, catastrophic bond failure.

It therefore would be advantageous to provide a hot melt adhesive that will overcome the shortcomings of the prior art adhesives herein mentioned above.

With the advancement in recent years of catalyst technology in the
25 manufacturing of polyolefins, especially with the newly developed single-site catalyst systems such as metallocenes, entirely new types of flexible, low melting point and low crystallinity random propylene copolymers (RCP) have been developed. The art of single-site metallocene catalysts is a subject of numerous publications, such as, for example, U.S. Patents 5,387,568, 5,393,851, 5,416,228,
30 5,476,914 to Ewen et al, and U.S. Patent 5,789,502 to Shamshoun et al. Compared

with conventional IPPs, the RCP copolymers usually have better flexibility, better impact resistance, lower density, much depressed melting point and lower crystallinity; these are the characteristics favoring hot melt adhesive applications. It is discovered in the present invention that RCP copolymers based on propylene and α -olefins can be advantageously used to overcome the drawbacks of IPP, SPP and APAO in hot melt adhesives to provide well balanced properties of cohesive strength and adhesive strength. Most importantly, the present invention provides a hot melt composition that can be easily processed with a variety of conventional hot melt coating equipment.

10

SUMMARY OF THE INVENTION

The present invention is directed to a hot melt adhesive composition based on a low melting point isotactic polypropylene random copolymer (RCP) which comprises a random copolymer of propylene and an α -olefin having the formula R-CH=CH₂ where R is a hydrogen or a C₂ to C₁₀ alkyl group, preferably ethylene. The useful polymers for the present invention will contain at least 1.5% by weight of the said α -olefin comonomer, and having a melting point of 145°C or lower, as measured by DSC method, a melt flow rate of 1 to 500 g/10 min. per ASTM Method D-1238, and a solid density of 0.880 to 0.905 g/cc per ASTM Method D-1505.

15
20

The adhesive comprises, in addition to the RCP copolymer, a tackifying resin, an optional plasticizer, an optional APAO, an optional wax and/or an optional secondary polymer as the primary ingredients. The composition of the present invention takes advantage of the desirable properties of RCP and has overcome the shortcomings of the prior art APAO blend adhesives and tackified SPPs. The composition of the present invention provides well balanced properties of tensile strength, toughness, flexibility and adhesion. It shows complete compatibility, excellent heat stability, adjustable open time, improved cohesive strength, low viscosity, low shrinkage upon solidification, low or no tack when set, and good processibility with conventional coating equipment. In particular, the

25
30

present invention leads to an adhesive composition that is well suited for a variety of spray coating application techniques, such as, for example, spiral spray, melt-blown, control coat, control wave and the like, whereas the prior art APAO and SPP based adhesives lack such broad processibility.

5 The above advantages are a result of the semi-crystalline structure of the RCP random copolymer. This type of stereochemical structure can be described as having the methyl groups attached to the carbon atoms of successive monomeric units on the same side of a hypothetical plane drawn through the main polymer chain with the α -olefin randomly located along the chain. Such a structure can be
10 illustrated graphically as follows:



The addition of an α -olefin, preferably ethylene, in a random pattern reduces the crystallinity of the polymer, and thus lowers the melting point as well as
15 slowing the rate of crystallization. As it has been pointed out hereinabove, the crystallization rate of a polymer is a critical factor affecting open time of the hot melt adhesive. In contrast to conventional isotactic polypropylenes (IPP) which give essentially no open time due to their fast crystallization rate, RCPs can be formulated to have workable open times, thereby overcoming the major hurdle of
20 IPPs for hot melt adhesives. The open time of RCP based hot melt adhesive can be adjusted through formulation to meet the requirements of various bonding applications. As such an RCP copolymer can be used by itself in a lotion resistant disposable diaper, in carton/case sealing applications, or can be blended with other
25 polymers such as APAO for elastic attachment or construction of nonwoven hygienic article assembly.

Although any RCP polymer of the type described hereinabove can be used in the composition of the present invention, a sub-group of metallocene catalyzed random copolymers, which will be referred to as mRCPs, are found to be the most useful and therefor most preferred. Compared with regular RCP polymers, mRCPs

offer additional benefits of narrow molecular weight distribution, narrow compositional distribution and even comonomer distribution along its molecular chain. At the same level of α -olefin comonomer content, mRCPs exhibit lower density, lower melting point and lower crystallinity than their regular RCP counterparts. These unique characteristics can greatly improve the handling of the polymer during compounding on one hand and enhance performance of hot melt adhesives on the other. The mRCP copolymers are especially desirable for hygienic nonwoven applications where low application temperature is a critical requirement to avoid substrate burn-through or distortion, and where broad application latitude through various non-contact coating techniques is also essential. In these regards, the mRCP polymers are capable of providing adhesive compositions having low softening point and low melt viscosity, thereby enabling low coating temperature. Moreover, due to their low density and low crystallinity, the mRCP polymers usually exhibit compatibility with other formulation ingredients, permitting the use of a broad range of raw materials in varying ratios.

One of the prominent features of the hot melt adhesive composition of the present invention is its ability to provide a strong bond to a variety of polar and nonpolar substrates at very low coating weight. The adhesive works well on both porous and film substrates. At the equal coating weight, the present adhesive will yield a much higher peel adhesion value than the prior art adhesives. The ability to yield high peel strength at low coating weight enables the end user to use less adhesive, which is obviously a great cost benefit.

One objective of the present invention is to provide an adhesive that has very low or no tack at ambient temperature. This feature is particularly advantageous for use on porous substrates where adhesive bleed-through and the subsequent blocking are of great concern. Blocking is especially disastrous in the manufacturing of roll-goods. The roll goods are usually intermittent products that will be converted to end products in a subsequent process. Roll blocking makes it difficult, and sometimes even impossible to unwind the roll in the subsequent converting process. The non-tacky characteristic of the present adhesive in

combination with low coating weight capability will eliminate the blocking problem.

Another objective of the present invention is directed towards a sprayable hot melt adhesive for construction of disposable nonwoven articles for binding polyethylene, polypropylene films, nonwoven fabrics and the like to each other and to themselves. The adhesive provides excellent peel strength and bond durability in such application.

Another objective of the present invention is to provide a sprayable hot melt for elastic attachment application in manufacturing baby diapers, adult incontinent briefs and the like for binding elastic strands between a polyethylene film and a nonwoven fabric, or between two nonwoven fabrics. This type of adhesive can be formulated to have dual functions for both elastic attachment and construction.

Another objective of the present invention is to provide a hot melt adhesive that has high bond strength retention when contacted with an emollient such as mineral oil.

Another objective of the present invention is to provide a hot melt adhesive for carton and case sealing to provide a strong bond. Due to its toughness and flexibility, an RCP/APAO based hot melt is advantageous for low temperature applications. The adhesive of the present invention would offer fiber tear bond at the ambient temperature.

The hot melt adhesive composition of the present invention comprises as components thereof a mixture of the following ingredients:

- a. An isotactic polypropylene random copolymer (RCP) in the amount of about 4% to 50% by weight, preferably in the amount of about 5% to 40% by weight, and most preferably in an amount of from about 5% to 25% by weight, said RCP having from about 80%-98% by weight propylene and from about 2%-20% by weight of an α -olefin having the formula $R-CH=CH_2$ where R is hydrogen or a C_2 to C_{10} alkyl group; said RCP having a preferred ratio of 94%-97% propylene and 3%-6% α -olefin with the preferred α -olefin being ethylene; said RCP having a density of

about 0.88g/cc to 0.905g/cc and a melt flow rate of equal to or greater than 1.0g/10 min and a melting point equal to or less than 145°C;

b. A compatible tackifier in the amount of 20% by weight to 65% by weight, preferably in the amount of 25% by weight to 60% by weight and most preferably in an amount of 30% to 60% by weight;

c. Optionally, about 0% to 60% by weight, preferably 15% to 40% by weight, and most preferably 20% to 40% by weight, of atactic poly- α -olefin (APAO), said APAO having a density of about 0.85 g/cc to 0.89 g/cc and a glass transition temperature (T_g) of from about -5 to -40°C and weight average molecular weight (M_w) of from about 4,000 g/mol to about 150,000 g/mol.;

d. Optionally, about 0% to 40% by weight, preferably about 5% to 30% by weight, and most preferably 10% to 25% by weight of a plasticizer;

e. Optionally, about 0% to 3% by weight of a stabilizer or antioxidant; and

f. Optionally, about 0% to 40% by weight, preferably about 0% to 30% by weight, and most preferably 0% to 20% weight of a wax;

the components of the composition adding up to 100% by weight. The adhesive composition may contain other components such as a filler and/or a colorant and/or a fluorescing agent and/or a surfactant and/or another polymer that can modify the adhesive properties of the above basic adhesive composition, as desired.

In one particularly preferred adhesive composition, RCP and a compatible tackifier, together with some or all of the optional ingredients (c) through (f) noted above, may be further blended with one or more of an optional secondary polymer. The secondary polymer functions to modify specific physical properties and/or characteristics of the RCP based adhesive composition, as desired. For example, the addition of one or more secondary polymers could be used to increase or decrease (i) the elasticity of the adhesive composition; (ii) the adhesion of the adhesive composition; (iii) the low temperature resistance of the adhesive

composition; (iv) the high temperature resistance of the adhesive composition; (v) the creep resistance of the adhesive composition; (vi) the cohesive strength of the adhesive composition; and/or (vii) the pressure sensitivity characteristics of the adhesive composition. Thus, the adhesive composition may further include:

- 5 g. Optionally, about 0% to 40% by weight of a secondary polymer, preferably about 0% to 30% by weight, and most preferably about 2% to 20% by weight of a secondary polymer.

As noted previously, either a single secondary polymer may be incorporated into the adhesive composition to modify a specific property of the adhesive
10 composition, or a blend of secondary polymers may be incorporated to modify several different properties, as desired.

BRIEF DESCRIPTION OF THE DRAWINGS

Fig. 1a illustrates schematically an undesired poor spiral spray pattern for
15 the adhesive of the present invention;

Fig. 1b illustrates schematically a desired perfect spiral spray pattern for the adhesive of the present invention;

Fig. 2 illustrates a schematic perspective view of a corrugated box having the adhesive of the present invention applied to top flaps thereof; and

20 Fig. 3 illustrates the corrugated box of Fig. 2 sealed by the adhesive of the present invention.

DETAILED DESCRIPTION OF THE INVENTION

In accordance with the present invention, a hot melt adhesive composition is
25 produced, comprising as the primary polymer component an isotactic polypropylene random copolymer (RCP) which comprises a random copolymer of propylene and an α -olefin having the formula $R-CH=CH_2$ where R is hydrogen or a C_2-C_{10} alkyl group, preferably ethylene. RCP is present in the adhesive composition in the amount of about 4% to 50% by weight, preferably in the amount
30 of about 5% to 40% by weight, and most preferably in an amount of from about 5%

to 25% by weight. The hot melt adhesive composition of the present invention also includes about 20% to 65% by weight, preferably about 25% to 60% by weight, and most preferably 30% to 60% by weight, of tackifier, about 0% to 40% by weight, preferably about 5% to 30% by weight, and most preferably 10% to 25%
5 by weight, of plasticizer, about 0% to 40% by weight, preferably about 0% to 30% by weight, and most preferably 0% to 20% by weight, of wax, about 0% to 3% by weight of stabilizer or antioxidant, about 0% to 60% by weight, preferably 15% to 40% by weight, and most preferably 20% to 40% by weight, of atactic poly- α -olefin (APAO), and about 0% to 40% by weight, preferably about 0% to 30% by
10 weight, and most preferably about 2% to 20% by weight, of a secondary polymer. Optional components such as filler, colorant, blowing agent, fluorescing agent, surfactant and the like can be added to the basic composition to further modify its properties, as desired.

The hot melt composition of the present invention includes a RCP
15 copolymer. The art of making CRP copolymers by using Ziegler-Natta catalysts has been disclosed in U.S. Patents 4,330,645 and 5,618,895, and by using metallocene catalysts in U.S. Patents 5,476,914 to Ewen et al and 5,789,502 to Shamshoun et al, the entire disclosures of which are hereby incorporated by reference. Suitable RCP polymers can be prepared by copolymerization of
20 propylene with another different α -olefin monomer containing 2 to 10 carbon atoms, which includes, but not limited to, ethylene, butene-1, petene-1, hexane-1, 4-methyl pentene-1, and octane-1. Copolymers prepared by using metallocene catalyst are preferred. The most preferred RCP polymers are mRCPs containing ethylene or butene-1 or hexane-1 as the comonomer having a comonomer content
25 ranging from about 2% by weight to about 20% by weight.

The RCP copolymers useful in the present invention preferably have a melting point equal to or less than 145°C, more preferably less than 125°C and most preferably less than 120°C. The RCP copolymers generally have a density in a range from about 0.88g/cc to about 0.905g/cc and preferably from 0.88g/cc to
30 0.89g/cc at room temperature as measured per ASTM D-1505 test method. The

polymer also has a melt flow rate (MFR), which is inversely related to weight average molecular weight M_w , equal to or greater than 1.0g/10 min., preferably between 5–200g/10 min. and more preferably between 7–100g/10 min., as measured per ASTM D-1238 test method. Examples of copolymers of this type are available under trade designation EOD01-03, EOD01-04, EOD01-05, EOD01-06, and EOD01-14 from ATOFINA Petrochemicals, Inc., Houston, TX.

The following Table 1 is a listing and comparison of the physical properties of some of the mRCP copolymers useful in the present adhesive composition:

10

TABLE 1

Sample	EOD00-14	EOD01-03	EOD01-04	EOD01-05	EOD01-06
Polymer type	mRCP	mRCP	mRCP	mRCP	mRCP
MFR g/10min	12.3	6.1	6.7	7.4	8.0
X-sol, %	0.5, 0.64*	1.1, 1.16*	1.5, 1.76*	2.1, 2.6*	4.7, 5.6*
Ethylene by NMR, wt. % (mole%)	1.5 (2.3)	2.3 (3.4)	3.2 (4.8)	4.7 (7.0)	6.5 (9.4)
Melting Point °C (DSC)	139.7	132.7	128.0	119.4	111.4
GPC					
$M_n \times 10^3$	59	78	81	72	65
$M_w \times 10^3$	173	234	239	229	212
M_w/M_n	2.9	3.0	3.0	3.2	3.3

The APAO component useful in the present invention consists of several different categories of atactic, low molecular weight, low melt viscosity, and substantially amorphous propylene based polymers. The term “substantially amorphous” is defined herein as having a degree of crystallinity less than 30%, as determined by differential scanning calorimetry (DSC) against a highly crystalline polypropylene standard. These polymers can be either homopolymers of propylene or copolymers of propylene with one or more α -olefin comonomer, such as, for example, ethylene, butene-1, hexene-1 and octene-1. The average weight molecular weight of the APAO polymers in the scope of the present invention is in the range of from about 4,000 to about 150,000 g/mol, preferably from about

10,000 to about 100,000 g/mol. The said polymers have advantageously a softening point between about 80 and 170 °C and a glass transition temperature from about -5 to -40 °C. Although any APAO polymer falling in the range of physical properties herein described above can be used, the most preferred APAO is selected from the
5 group consisting of propylene homopolymer, propylene-ethylene copolymer, propylene-butene-1 copolymer and propylene-ethylene-butene-1 terpolymer. The APAO polymers of the types herein described above are commercially available from Eastman Chemical Company, Kingsport, TN, under the trade name designation Eastoflex or from Huntsman Corporation, Houston, TX, under the
10 trade name designation Rextac or from Degussa Corporation, Passipanny, NJ, under the trade name designation Vestoplast. As noted, 0% to 60% by weight APAO may be blended into the adhesive composition, preferably 15% to 40% by weight, and most preferably 20% to 40% by weight.

The tackifying resins or tackifiers which are used in the hot melt adhesives
15 of the present invention are those which extend adhesive properties and improve specific adhesion. As used herein, the term "tackifying resin" include:

(a) aliphatic and cycloaliphatic petroleum hydrocarbon resins having Ring and Ball softening points of from 10 °C to 160 °C, as determined by ASTM method E28-58T, the latter resins resulting from the
20 polymerization of monomers consisting primarily of aliphatic and/or cycloaliphatic olefins and diolefins; also included are the hydrogenated aliphatic and cycloaliphatic petroleum hydrocarbon resins; examples of such commercially available resins based on a C5 olefin fraction of this type are Piccotac 95 tackifying resin sold by Eastman Chemical Company, and
25 Escoreze 1310LC sold by ExxonMobil Chemical Company;

(b) Aromatic petroleum hydrocarbon resins and the hydrogenated derivatives thereof;

(c) Aliphatic/aromatic petroleum derived hydrocarbon resins and the hydrogenated or acid functionalized derivatives thereof;

(d) Aromatic modified cycloaliphatic resins and the hydrogenated derivatives thereof;

(e) Polyterpene resins having a softening point of from about 10°C to about 140°C, the latter polyterpene resins generally resulting from the polymerization of terpene hydrocarbons, such as the mono-terpene known as pinene, in the presence of Friedel-Crafts catalysts at moderately low temperatures; also included are the hydrogenated polyterpene resins;

(f) Copolymers and terpolymers of natural terpenes, e.g. styrene/terpene, α -methyl styrene/terpene and vinyl toluene/terpene;

(g) natural and modified rosin such as, for example, gun rosin, wood rosin, tall-oil rosin, distilled rosin, hydrogenated rosin, dimerized rosin and polymerized rosin;

(h) glycerol and pentaerythritol esters of natural and modified rosin, such as, for example, the glycerol ester of pale wood rosin, the glycerol ester of hydrogenated rosin, the glycerol ester of polymerized rosin, the pentaerythritol ester of pale wood rosin, the pentaerythritol ester of hydrogenated rosin, the pentaerythritol ester of tall-oil rosin, and the phenolic modified pentaerythritol ester of rosin;

(i) phenolic-modified terpene resins such as, for example, the resin product resulting from the condensation in an acidic medium of a terpene and a phenol;

Mixtures of two or more of the above described tackifying resins may be required for some formulations. Although a range of 20% to 65% by weight tackifying resin may be used, the preferred amount is from about 25% to about 60% by weight, and the most preferred amounts range from 30% to 60% by weight. Tackifying resins which are useful for the present invention can perhaps include polar tackifying resins, however, the choice of available polar tackifying resins is limited in view of the fact that many of the polar resins appear only partially compatible with metallocene catalyzed polypropylene mRCP copolymers and APAO polymers.

As noted above, tackifying resins which are useful within the scope of the present invention comprise about 20% to 65% by weight. Preferably, the tackifying resins can be selected from any of the nonpolar types, which are commercially available. Preferred resins are aliphatic petroleum hydrocarbon resins examples of which are based on C5 olefins such as Piccotac 9095 (formerly Hercotac 1148) available from Eastman Chemical Company, Kingsport, TN. Most preferred are nonpolar products which are hydrogenated DCPD based or aromatically modified derivatives thereof with softening points above 70 °C. Examples of such resins are Escoreze 5400 and Escoreze 5600 sold by ExxonMobil Chemical company.

10 A plasticizer can be present in the composition of the present invention in amounts of 0% to about 40% by weight, preferably from about 5% to about 30%, and most preferably 10% to 25% by weight, in order to provide desired viscosity control and to impart flexibility. A suitable plasticizer may be selected from the group which includes the usual plasticizing oils, such as mineral oil, but also olefin
15 oligomers and low molecular weight polymers, as well as vegetable and animal oils and derivatives of such oils. The petroleum derived oils which may be employed are relatively high boiling materials containing only a minor proportion aromatic hydrocarbons. In this regard, the aromatic hydrocarbons should preferably be less than 30% and more particularly less than 15% of the oil, as measured by the
20 fraction of aromatic carbon atoms. More preferably, the oil may be essentially non-aromatic. The oligomers may be polypropylenes, polybutenes, hydrogenated polyisoprenes, hydrogenated polybutadiens, or the like having average molecular weight between about 350 and about 10,000. Suitable vegetable and animal oils include glycerol esters of the usual fatty acids and polymerization products thereof.
25 Other useful plasticizers can be found in the families of conventional dibenzoate, phosphate, phthalate esters, as well as esters of mono- or polyglycols. Examples of such plasticizers includes, but are not limited to dipropylene glycol dibenzoate, pentaerythritol tetrabenzoate, 2-ethylhexyl diphenyl phosphate, polyethylene glycol 400-di-2-ethylhexoate; butyl benzyl phthalate, dibutyl phthalate and
30 dioctylphthalate. The plasticizers that finds usefulness in the present invention can

be any number of different plasticizers but the inventors have discovered that mineral oil and liquid polybutenes having average molecular weight less than 5,000 are particularly advantageous. As will be appreciated, plasticizers have typically been used to lower the viscosity of the overall adhesive composition without
5 substantially decreasing the adhesive strength and/or the service temperature of the adhesive as well as to extend the open time and to improve flexibility of the adhesive.

Waxes can be used to reduce the melt viscosity of the hot melt adhesive composition. Although amounts varying from about 0% to 40% by weight may be
10 used in the composition of the present invention, the preferred amounts are between 0% to 30% by weight, and most preferably between 0% to 20% by weight. These waxes can also effect the set-up time and the softening point of the adhesive.

Among the useful waxes are:

1. low molecular weight, that is, number average molecular
15 weight (Mn) equal to 500 – 6000, polyethylene having a hardness value, as determined by ASTM method D-1321, of from about 0.1 to 120, having an ASTM softening point of from about 65 °C to 140 °C;
2. petroleum waxes such as paraffin wax having a melting point
20 of from about 50 °C to 80 °C and microcrystalline wax having a melting point of from about 55 °C to 100 °C, the latter melting points being determined by ASTM method D127-60;
3. synthetic waxes made by polymerizing carbon monoxide and
hydrogen such as Fischer-Tropsch wax; and
4. polyolefin waxes. As used herein, the term “polyolefin wax”
25 refers to those polymeric or long-chain entities comprised of olefinic monomer units. This type of materials are commercially available from Eastman Chemical Co. under the trade name designation “Epolene”. The materials which are preferred for use in the composition of the present invention have a Ring and Ball softening point of from about 100°C to

170°C. As should be understood, each of these wax diluents is solid at room temperature.

Other substances which include hydrogenated animal, fish and vegetable fats and oils such as hydrogenated tallow, lard, soya oil, cottonseed oil, castor oil, menhaden oil, cod liver oil, and the like, and which are solid at the room temperature by virtue of their being hydrogenated, have also been found to be useful with respect to functioning as a wax diluent equivalent. These hydrogenated materials are often referred to in the adhesive industry as "animal or vegetable waxes".

The present invention may include a stabilizer in an amount of from about 0% to about 3% by weight. Preferably from about 0.1% to 1% of a stabilizer is incorporated into the composition. The stabilizers which are useful in the hot melt adhesive compositions of the present invention are incorporated to help protect the polymers noted above, and thereby the total adhesive system, from the effects of thermal and oxidative degradation which normally occurs during the manufacture and application of the adhesive as well as in the ordinary exposure of the final product to the ambient environment. Among the applicable stabilizers are high molecular weight hindered phenols and multifunction phenols, such as sulfur and phosphorous-containing phenols. Hindered phenols are well known to those skilled in the art and may be characterized as phenolic compounds that also contain sterically bulky radicals in close proximity to the phenolic hydroxyl group thereof. In particular, tertiary butyl groups generally are substituted onto the benzene ring in at least one of the ortho positions relative to the phenolic hydroxyl group. The presence of these sterically bulky substituted radicals in the vicinity of the hydroxyl group serves to retard its stretching frequency and correspondingly, its reactivity; this steric hindrance thus providing the phenolic compound with its stabilizing properties. Representative hindered phenols include:

1,3,5-trimethyl-2,4,6-tris(3,5-di-tert-butyl-4-hydroxybenzyl) benzene;
pentaerythritol tetrakis-3(3,5-di-tert-butyl-4-hydroxyphenyl) propionate;
n-octadecyl-3(3,5-di-tert-butyl-4-hydroxyphenyl) propionate;

4,4'-methylenebis(4-methyl-6-tert butylphenol);
2,6-di-tert-butylphenol;
6-(4-hydroxyphenoxy)-2,4-bis(n-octylthio)-1,3,5-triazine;
2,3,6-tris(4-hydroxy-3,5-di-tert-butyl-phenoxy)-1,3,5-triazine;
5 di-n-octadecyl-3,5-di-tert-butyl-4-hydroxybenzylphosphonate;
2-(n-octylthio)ethyl-3,5-di-tert-butyl-4-hydroxybenzoate; and
sorbitol hexa-3(3,5-di-tert-butyl-4-hydroxy-phenyl) propionate.

Especially preferred as a stabilizer is pentaerythritol tetrakis-3(3,5-di-tert-butyl-4-hydroxyphenol) propionate.

10 The performance of these stabilizers may be further enhanced by utilizing, in conjunction therewith; (1) synergists such as, for example, thiodipropionate esters and phosphites; and (2) chelating agents and metal deactivators such as, for example, ethylenediaminetetraacetic acid, salts thereof, and disalicylalpropylenediimine.

15 The optional secondary polymer can be present in the composition of the present invention in amounts of from about 0% to 40% by weight, preferably from about 0% to 30% by weight, and most preferably from about 2% to 20% by weight. As used herein, the term "secondary polymer" refers to thermosetting and thermoplastic materials composed of a homopolymer, a copolymer, a terpolymer
20 and/or blends of homopolymers, copolymers, or terpolymers. Either a single secondary polymer may be used, or mixtures of two or more secondary polymers may be incorporated into the adhesive composition, depending upon the formulation desired.

Any of a variety of well-known and readily available thermosetting materials
25 can be used as the secondary polymer in the adhesive compositions. Examples of such materials include polyacrylates, polyesters, polyurethanes, polyepoxides, graft copolymers of one or more vinyl monomers and polyalkylene oxide polymers, aldehyde containing resins such as phenol-aldehyde, urea-aldehyde, melamine-aldehyde and the like, as well as polyimides.

Any of a variety of well-known and readily available thermoplastic materials can also be used as the secondary polymer in the adhesive compositions. Examples of such materials include ethylene based polymers, including ethylene vinyl acetate, ethylene acrylate, ethylene methacrylate, ethylene methyl acrylate, ethylene methyl methacrylate, an ethylene-styrene interpolymer (ESI), an ethylene acrylic acid, ethylene vinyl acetate carbon monoxide, and ethylene N-butyl acrylate carbon monoxide; polybutene-1 polymers; polyolefins such as high and low density polyethylene; polyethylene blends and chemically modified polyethylene, copolymers of ethylene and C₁-C₆ mono- or di-unsaturated monomers; polyamides; polybutadiene rubber; polyesters such as polyethylene terephthalate, and polybutylene terephthalate; thermoplastic polycarbonates; atactic polyalphaolefins, including atactic polypropylene, polyvinylmethylether and others; thermoplastic polyacrylamides, such as polyacrylonitrile, and copolymers of acrylonitrile and other monomers such as butadiene styrene; polymethyl pentene; polyphenylene sulfide; aromatic polyurethanes; polyvinyl alcohols and copolymers thereof; polyvinyl acetate and random copolymers thereof; styrene-acrylonitrile, acrylonitrile-butadiene-styrene, styrene-butadiene rubbers, acrylonitrile-butadiene-styrene elastomers, A-B, A-B-A, A-(B-A)_n-B, (A-B)_n-Y block copolymers wherein the A block comprises a polyvinyl aromatic block such as polystyrene, the B block comprises a rubbery midblock which can be polyisoprene, and optionally hydrogenated, such as polybutadiene, Y comprises a multivalent compound, and n is an integer of at least 3, and mixtures of said substances. Examples of these latter block copolymers including styrene-butadiene, styrene-butadiene-styrene, styrene-isoprene-styrene, styrene-ethylene-butylene-styrene and styrene-ethylene propylene-styrene.

While the total styrene content of the polymers can be as much as 51 wt-% of the polymer, and since the polymers can have more than two A blocks for optimal performance, the total A block preferably should be less than or equal to about 45 wt-% of the polymers, and, most preferably, is less than or equal to 35 wt-% of the polymer. In an S-B-S (styrene-butadiene-styrene) copolymer, the preferred

molecular weight is about 50,000 to 120,000, and the preferred styrene content is about 20 to 45 wt-%. In an S-I-S (styrene-isoprene-styrene) copolymer, the preferred molecular weight is about 100,000 to 200,000 and the preferred styrene content is about 14-35 wt-%. Hydrogenating the butadiene midblocks produces rubbery
5 midblocks that are typically converted to ethylene-butylene midblocks.

Such block copolymers are available from Kraton Polymers, Enichem, Fina and Dexco. Multiblock or tapered block copolymers (the A-(B-A)_n-B type) are available from Firestone.

Other secondary polymers that could be used are syndiotactic polypropylene
10 (SPP) polymers and/or blends of SPP with amorphous atactic poly- α -olefins (APAO), all of which are well known in this art. The SPP polymers are essentially high molecular weight stereospecific propylene homopolymers or copolymers of propylene with other α -olefin monomers such as ethylene, butene-1 or hexene-1. APAO polymers are a family of essentially amorphous low molecular weight
15 homopolymers of propylene or copolymers of propylene with ethylene or butene or hexene, as previously described herein.

The secondary polymer functions to modify specific polymer functions to modify specific physical properties and/or characteristics of the RCP based adhesive composition, as desired. For example, the addition of one or more secondary
20 polymers could be used to increase or decrease (i) the elasticity of the adhesive composition; (ii) the adhesion of the adhesive composition; (iii) the low temperature resistance of the adhesive composition; (iv) the high temperature resistance of the adhesive composition; (v) the creep resistance of the adhesive composition; (vi) the cohesive strength of the adhesive composition; and/or (vii) the pressure sensitivity
25 characteristics of the adhesive composition. The relative change (increase or decrease) of the above characteristics is measured relative to the adhesive composition without the addition of the secondary polymer. Thus, for example, Kraton G1652 or Kraton G1657, both of which are styrene/ethylene-butylene/styrene (SEBS) block copolymers, may be added to provide increased elongation
30 characteristics to the RCP polymer in order to increase the elasticity of the adhesive

composition. Increased elasticity results in better sprayability characteristics for the adhesive composition. In another example, Eastoflex 1003 or Eastoflex 1060, both ethylene based APAO's, may be added to provide increased adhesion characteristics for the composition, if desired.

5 As used herein, the term "elasticity" is the ability of a material to recover its original shape partially or completely after the deforming force has been removed.

As used herein, the term "adhesion" means the state in which two surfaces are held together by interfacial forces, which may be a combination of valence forces or interlocking action, or both.

10 As used herein, the term "low temperature resistance" means the relative ability of an adhesive to retain its bond strength and structural integrity at relatively low temperatures (i.e. below room temperature).

As used herein, the term "high temperature resistance" means the relative ability of an adhesive to retain its bond strength and structural integrity at elevated
15 temperatures (e.g. body temperature or warehouse conditions).

As used herein, the term "creep resistance" means the ability of an adhesive to maintain stretched elastic strands in place without significant slippage. Further definition can be found as in Examples 1-4 contained herein.

As used herein, the term "cohesive strength" means the degree of internal
20 strength of a material to resist deformation. Various ways of determining cohesive strength exist, such as a tensile test method using a Instron type tensile tester.

As used herein, the term "pressure sensitivity" means the ability of an adhesive to form a bond to a substrate using only pressure.

It should be understood that other optional additives may be incorporated
25 into the adhesive composition of the present invention in order to further modify particular physical properties. These may include, for example, such materials as inert colorants (e.g. titanium dioxide), fluorescent agents, 0% to 60% by weight fillers, surfactants and/or blowing agents. Typical fillers include talc, calcium carbonate, clay, silica, mica, wollastonite, feldspar, aluminum silicate, alumina,
30 hydrated alumina, glass microspheres, ceramic microspheres, thermoplastic

microspheres, baryte and wood flour. Surfactants are particularly important in adhesives for use in hygienic disposable nonwovens because they can dramatically reduce the surface tension, for example, of the adhesive applied to diaper core, thereby permitting quicker transport and subsequent absorption of urine by the
5 core.

A surfactant can be present in the composition of the present invention in amounts of from about 0.1% to about 30%, by weight, and preferably from about 1% to about 10% in order to make the adhesive more hydrophilic. The surfactant preferably has a hydrophile-lipophile balance (HLB) number of less than 15. The
10 HLB of a surfactant is an expression of its hydrophile-lipophile balance, i.e. the balance of the size and strength of the hydrophilic (water-loving or polar) and the lipophilic (oil-loving or non-polar) groups of the surfactant. All surfactants consist of a molecule that combines both hydrophilic and lipophilic groups.

The surfactant must be reasonably compatible with the other raw materials
15 used in the hot melt adhesive so that it does not adversely affect the performance of the adhesive. On the other hand, the surfactant must "bloom" to the surface of the adhesive so as to make the adhesive more hydrophilic. Thus, a delicate balance of compatibility must be maintained. The surfactant also should not contain any water or other solvents making it processable in hot melt mixing equipment and non-toxic
20 for the end user. The surfactant also must be sufficiently stable and non-volatile to allow processing in hot melt manufacturing and application equipment without effect on the adhesive.

As used herein the term "surfactant" or "surface-active agent" refers to any compound that reduces surface tension when dissolved in water or water solutions,
25 or which reduces interfacial tension between two liquids, or between a liquid and a solid. Examples of suitable surfactants include, but are not limited to, the following:

(1) Fatty acid esters such as glycerol esters, PEG esters, and sorbitan esters, including ethylene glycol distearate, ethylene glycol monostearate, glycerol
30 mono and/or dioleate, PEG dioleate, PEG monolaurate, sorbitan monolaurate,

sorbitan trioleate, etc. These surfactants are available from ICI, Thone-Poulenc, and other sources.

(2) Nonionic ethoxylates such as alkylphenol ethoxylates, alcohol ethoxylates, alkylamine ethoxylates, etc., including octylphenol ethoxylate, nonylphenol ethoxylate, alkylamine ethoxylates, etc. These surfactants are available from Rhone-Poulenc, Union Carbide, and other sources.

(3) Nonionic surfactants such as 2,4,7,9-tetramethyl-5-decyn-4,7-diol available from Air Products.

(4) Ethylene oxide/Propylene oxide copolymers which are available from Union Carbide, BASF, etc. It should be noted that these and other surfactants can be blended if necessary to produce the best blend of hydrophilic performance properties.

Atmer 688, a nonionic surfactant blend, and Alkamuls GMS/C a glycerol monostearate, both manufactured by ICI Americas, Inc. have been found to be preferred surfactants for use in the present adhesive composition.

The hot melt adhesive composition of the present invention may be formulated using any of the mixing techniques known in the art. A representative example of the prior art mixing procedure involves placing all the components, except the RCP polymer, in a jacketed mixing kettle equipped with a rotor, and thereafter raising the temperature of the mixture to a range from 160 °C to 200 °C to melt the contents. It should be understood that the precise temperature to be used in this step would depend on the melting points of the particular ingredients. The RCP copolymer and/or other polymers (e.g. APAO) are subsequently introduced to the kettle under agitation and the mixing is allowed to continue until a consistent and uniform mixture is formed. The content of the kettle is protected with inert gas such as carbon dioxide or nitrogen during the entire mixing process.

The resulting hot melt adhesives may be then applied to substrates using a variety application technique. Examples includes hot melt glue gun, hot melt slot-die coating, hot melt wheel coating, hot melt roller coating, melt blown coating, spiral spray and the like. In a preferred embodiment, the hot melt adhesive is

sprayed onto a substrate using spiral spray, which is a preferred technique to produce a filamentary spiral pattern for elastic attachment and construction in diaper manufacturing. In one example, a hot melt coater is equipped with a disc like coating die which has a nozzle tip in the center. The tip is surrounded with a series of inclined orifices for hot air jets to pass through. The hot melt adhesive is pumped out of the nozzle in the form of a fine filament. The filament is then rotated by high-velocity hot air jets coming out of the orifices, thereby producing a helical pattern from a single strand of adhesive. It is not the intent of this invention to provide a full description of spray techniques and the details can be found in the literature.

The adhesive composition of the present invention may be used in a number of applications such as, for example, in disposable nonwoven hygienic articles, paper converting, flexible packaging, wood working, carton and case sealing, labeling and other assembly applications. Particularly preferred applications include disposable diaper and feminine sanitary napkin construction, diaper and adult incontinent brief elastic attachment, diaper and napkin core stabilization, diaper backsheet lamination, industrial filter material conversion, surgical gown and surgical drape assembly, etc.

TESTS AND MATERIALS

Brookfield viscosity was tested according to ASTM D-3236 Method at 325°F.

Ring & Ball softening point was determined with an automated Herzog unit according to ASTM E-28 method.

Peel strength was measured in 180° geometry with a tensile tester (Instron Model 55R1122) in the controlled atmospheric environment (20 °C and 50% relative humidity). Prior to the test, the specimens were conditioned at the controlled environment for approximately 12 hours to ensure the reproducibility and accuracy of the data. The test was done at a cross-head speed of 12"/min. The

average peel value of six replicates, normalized to g/in unit, was reported as the peel strength.

Creep Resistance test was carried out with the laminated specimens of the Examples herein later described. The specimen, cut to about 350 mm in length, was stretched out completely and its ends were securely attached to a piece of rigid corrugated paperboard. A length of 300 mm was marked and the elastic strands were cut at the marks. The specimen was then placed in an air-circulating oven at 100 °F. Under these conditions, the elastic strands under stretch can retreat to a certain distance. The distance between the ends was measured after four hours. The ratio of the final length to the initial length, defined as Creep Retention and expressed in percentage (%), is a measure of the ability of the adhesive to hold the elastic strands.

Sprayability was measured empirically on a Meltex CT225 (Nordson) hot melt coater. The coating conditions varied depending on the adhesive sample.

EOD01-06 is a propylene-ethylene copolymer type of mRCP prepared by using a single-site metallocene catalyst system such as that disclosed in U.S. Patent 5,476,914. The copolymer contains about 6% by weight of ethylene and is commercially available from AtoFina Petrochemicals, Inc., Houston, TX. It has a density of 0.89 g/cc and a DSC melting point of 111.4°C, and has a melt flow rate of about 8 g/10 min. as determined by using ASTM Method D-1238.

EOD00-14 is a propylene-ethylene copolymer type of mRCP prepared by using a single-site metallocene catalyst system such as that disclosed in U.S. Patent 5,476,914. The copolymer contains about 2% by weight of ethylene and is commercially available from AtoFina Petrochemicals, Inc., Houston, TX. It has a density of 0.90g/cc and a DSC melting point of 139.7°C, and has a melt flow rate of about 14g/10 min. as determined by using ASTM Method D-1238.

EOD02-07, obtained from AtoFina Petrochemicals, is a propylene-ethylene copolymer mRCP having about 6% by weight ethylene. It has a melting point of about 112°C, a density of 0.89g/cc and a melt flow rate of about 50g/10min.

EOO02-08, obtained from AtoFina Petrochemicals, is a propylene-ethylene copolymer mRCP having about 6% by weight ethylene. It has a melting point of about 112°C, a density of 0.89g/cc and a melt flow rate of about 100g/10 min

Rextac RT2330, available from Huntsman Corporation, is an atactic
5 propylene-ethylene copolymer type of APAO having a Brookfield viscosity of about 3,000 cP at 190 °C, a Tg of about -29 °C and a softening point of about 141 °C.

Eastoflex P1010, obtained from Eastman Chemical Company, Kingsport, TN, is an atactic homopolypropylene type of APAO having a Brookfield viscosity
10 of about 1,000 cP at 190 °C, a Tg of about -10 °C and a softening point of about 150 °C.

Eastoflex D-178, also obtained from Eastman Chemical Company, is an atactic propylene-ethylene copolymer type of APAO having a Brookfield viscosity of about 3,000cP at 190°C, a Tg of -27°C and a softening point of about 130°C.

15 Eastoflex E-1200, also obtained from Eastman Chemical Company, is an atactic propylene-ethylene copolymer type of APAO having a Brookfield viscosity of about 12,000 cP at 190 °C, a Tg of about -28 °C and a softening point of about 135 °C.

Escorez 5380, available from ExxonMobil Chemical Company, Houston,
20 TX, is a very light color, hydrogenated cycloaliphatic hydrocarbon tackifier having an R&B softening point of about 80 °C.

Hercotac 1148 is a C5 aliphatic hydrocarbon resin having a Ring & Ball softening point of 100 °C. It is available from Eastman Chemical Company.

Nyplast 222B is a mineral oil plasticizer purchased from Nynas Canada,
25 Inc., Mississauga, Ontario, Canada.

Wingtack 10 is a liquid aliphatic C5 hydrocarbon resin having a Brookfield viscosity of about 20,000-40,000 cP at 25°C and a Ring and Ball softening point of about 10°C. It is available from Goodyear Chemicals, Akron, OH.

Marcus 300, available from Marcus Oil & Chemicals, Inc., is a synthetic
30 polyethylene wax having a melting point of about 240 °F.

Irganox 1010 is a hindered phenol type of antioxidant obtained from Ciba-Specialty Chemicals, Tarryton, NY.

Uvitex OB, also obtained from Ciba Specialty Chemicals, is a fluorescing agent.

5 Lycra 740 is an elastic strand having a basis weight of 740 denier. It is available from DuPont.

Control A is a styrene-isoprene-styrene (SIS) block copolymer based hot melt adhesive having a Brookfield viscosity of 5600 cP at 350°F and a Ring and Ball softening point of about 220°F. It is available from Bostik Findley, Inc.,
10 Wauwatosa, WI.

SMS is a spunbond-melt blown-spunbond composition nonwoven fabric obtained from Kimberly-Clark Corporation, Neenah, WI.

The invention is further illustrated by way of the examples which are set forth below.

15

EXAMPLES 1 – 4

Hot melt adhesive examples of 1 – 4 shown in Table 2 were prepared with the ingredients and mixing procedures described herein above. A total of 2000 grams each were made and the mixing was carried out at 350 - 375 °F under carbon
20 dioxide atmosphere in a laboratory type of mixer what consists of a propeller powered by a motor, a heating mantle, a temperature control unit and a container of about 1 gallon in size. The appropriate amounts of each component, calculated according to the ratios shown in the table, except the mRCP copolymer were added to the container. The temperature of the container was then raised to melt the
25 contents. After the ingredients in the container were completely melted, the motor was turned on to start agitation. Subsequently, the mRCP copolymer component was introduced, and mixed thoroughly therein. The adhesive examples 1 – 4 are especially useful as elastic attachment adhesive for elastic attachment applications.

Brookfield Viscosity, Ring and Ball Softening Point and Creep Retention
30 tests were carried out on Examples 1 – 4 according to the procedures herein

described above. The room temperature tack was judged by the adhesive's stickiness to human fingers. Specimens for Creep Retention test were formed by using spiral spray technique on Meltex CT225 hot melt coater which was fitted with a 0.018" spiral spray nozzle. To prepare the specimen, three elastic strands (Lycra 740), which were stretched to 300% elongation, were either laminated between a layer of 1.0 mil thick polyethylene film and a layer of polypropylene spunbond nonwoven fabric, or between two identical SMS nonwoven fabrics. Sprayability was evaluated during the coating process by observing the shape of the spiral pattern. The sprayability was deemed acceptable if a good spiral pattern as that depicted in Figure 1b was observed; otherwise, it was deemed unacceptable (Figure 1a). Adhesives were spiral sprayed at 12g/m² coating weight with 0.25 seconds open time and 1 bar compression at the nip rolls and the application temperature was set at 325°F. The adhesives of Examples of 1 – 4 were found to have almost no room temperature tack, low melt viscosity, good sprayability and good creep retention properties.

TABLE 2
EXAMPLES 1 – 4 (ELASTIC ATTACHMENT)

	EX 1 (wt. %)	EX 2 (wt. %)	EX 3 (wt. %)	EX 4 (wt. %)
EOD01-06	8.0	8.0	10.0	---
EOD02-07	---	---	---	10.0
Eastoflex P1010	30.0	35.5	---	---
Eastoflex D178	---	---	---	20.0
Rexflex RT 2330	---	---	30.0	
Wingtack 10	10.0	---	---	---
Hercotac 1148	46.5	46.0	47.0	59.5
Nyplast 222B	5.0	10.0	12.5	10.0
Irganox 1010	0.5	0.5	0.5	0.5
Viscosity (cP), 325°F	2880	3090	6250	2090
Softening Point (°F)	275	282	249	240
¹ Creep retention (%)				
Poly/Lycra/NW	94	96	91	83
SMS/SMS	87	94	85	71

EXAMPLES 5 - 7

Examples of 5 - 7 were formulated by using the same procedure as herein described above with the ingredients listed in Table 3. These formulations are particularly suited as laminating adhesives for a variety flexible packaging applications and as construction adhesives for disposable nonwoven applications. When used as such, the peel strength is the most important measure of adhesive performance. The peel strength of Examples 5 - 7 was measured and the results were also reported in Table 3. The specimens for the peel strength measurement were prepared by laminating the same polyethylene film and polypropylene spunbond nonwoven fabric as in Examples 1 - 4 with spiral spray coating technique on CT225 hot melt coater equipped with three ITW controlled fiberization nozzles. The adhesive was applied in the amount of 4 g/m² at 300 °F application temperature and 0.5 seconds open time. The adhesives of Examples of 5 - 7 were found to have almost no or very low room temperature tack, low melt viscosity, good sprayability and good film/nonwoven bond.

TABLE 3
EXAMPLES 5 - 7 (CONSTRUCTION)

	EX 5 (wt. %)	EX 6 (wt. %)	EX 7 (wt. %)
EOD01-06	10.0	---	---
EOD02-08	---	15.0	10.0
Eastoflex E-1200	6.0	---	20.0
Eastoflex D178	9.0	30.0	10.0
Hercotac 1148	44.5	34.5	39.5
Nyplast 222B	30.0	20.0	20.0
Irganox 1010	0.5	0.5	0.5
Viscosity (cP), 325 °F	3750	3490	3180
Softening Point (°F)	218	235	237
Coating T (°F)	300	300	300
¹ Peel Str. (g)	432	371	373

EXAMPLES 8-9

Hot melt adhesives of Examples 8-9 were prepared by using the same procedure as herein described above with the ingredients listed in Table 4. In Examples 8 and 9 the adhesive contains a wax (Marcus 300) substituted for the

APAO ingredient in the prior formulations illustrated herein. Thus, the adhesives of Examples 8 and 9 contain no APAO. A total of 250 grams each were made and the mixing was conducted at 350 °F under CO₂ atmosphere. They are particularly useful for case and carton sealing applications. To illustrate the use for such application, reference is made to Figs. 2 and 3 herein where single adhesive beads of about 2 mm in diameter, illustrated as 21a and 21b in Figure 2, was applied by hand across the upper surface of top flaps 22a and 22b of a corrugated box 20 as shown in the figure. Immediately after the adhesive application, the top flaps 22a and 22b of box 20 were folded over and brought into contact with bottom flaps 23a and 23b to seal the box 20. The flaps 22a, 22b, 23a and 23b were then held together by pressure means for approximately 2 minute to seal box 20 as shown in Fig. 3. The adhesive yielded a fiber tearing bond in about 20 minutes after the adhesive application.

TABLE 4
 EXAMPLES 8 – 9

	EX 8	EX 9
EOD00-14	15.0	---
EOD02-08	---	30.0
Marcus 300	18.0	5.0
Escorez 5380	56.0	49.0
Nyplast 222B	10.0	15.0
Irganox 1010	1.0	1.0
Viscosity @ 325 °F (CP)	3550	7150
Softening Point (°F)	253	225

EXAMPLES 10-11

Examples 10 – 11 were formulated by using the same procedure as herein described above with the ingredients listed in Table 5. These formulations are particularly suited as lotion resistant adhesives for disposable nonwoven applications.

Manufacturers of feminine care pads, diapers and other absorbent articles may from time to time apply a coating of emollient on the skin-engaging surface of the top sheet of a disposable diaper or a coating of emollient on the skin-engaging

surface of the topsheet of a feminine care pad. This emollient is intended to help prevent skin rashes that may develop during use of such articles. Petrolatum is particularly preferred because of its relatively low cost and excellent properties. Mineral oil and other oil-based ointments or lotions are also often rubbed on the skin of infants by the caregiver to treat and/or prevent skin rashes.

It is believed that emollients disturb the bond of adhesives by two mechanisms. First, they migrate into the adhesive substrate interface and thereby disrupt the bond. Second, the emollient is absorbed into and plasticizes the adhesive which reduces the cohesive strength of the adhesive. Thus, prior hot melt adhesive compositions, upon exposure thereto, experience adhesive bond failure. As a result, the elastic leg bands of a disposable diaper may actually let loose from the diaper resulting in complete failure and break down of the inner leg cuff. Also, construction adhesives may fail resulting in undesirable delamination of the absorbent article. Therefore, an adhesive that is capable of withstanding exposure to emollients while still providing sufficient bond strength would be highly desirable.

In order to determine the effectiveness against emollients, the creep resistance test was performed using the adhesives formulated according to Table 5.

The adhesives were coated on a SMS substrate, at 15 g/m² coating weight by using the spiral spray coating method herein described above. Three strands of Lycra elastics, stretched to 300% were laminated between the two identical SMS substrates. Immediately after combining the nonwoven substrates and Lycra strands to form a laminate, however, emollient was applied online at 5 g/m² coating weight and thereafter the lamination was tested for elastic creep performance. The results are reported in Table 5 below.

TABLE 5
EXAMPLES 10 – 11 (LOTION RESISTANT FORMULATION)

	EX 10 (wt. %)	EX 11 (wt. %)	Control A
EOD02-07	25	---	
EOD02-08	---	25	
Hercotac 1148	54.5	54.5	
Nyplast 222B	20	20	
Irganox 1010	0.5	0.5	
Uvitex OB	0.01	0.01	
Viscosity (cP), 325 °F	9050	5560	
Softening Point (°F)	226	230	
Coating T (°F)	375	350	350
¹ Creep (%)	84	85	Delamination

As seen, the adhesives performed exceptionally well as an elastic attachment
 5 adhesive while also providing very good creep performance after emollient
 exposure. In comparison, the commercial styrenic block copolymer based hot melt
 adhesive designated in Table 5 as Control A delaminated under the same
 conditions.

10 EXAMPLES 12-30

Examples 12-30 were formulated by using the same procedure as herein
 described above with ingredients listed in Table 6. The formulations of Examples
 12 and 13 did not contain a secondary polymer whereas the formulations of
 Examples 14 through 30 all contained one or more secondary polymers. Examples
 15 12 and 13 have relatively low tensile strength and elongation whereas the
 compositions containing the secondary polymers all have much higher tensile
 strength and/or elongation.

TABLE 6

	Example 12*	Example 13*	Example 14	Example 15	Example 16	Example 17	Example 18	Example 19	Example 20	Example 21	Example 22	Example 23	Example 24	Example 25	Example 26	Example 27	Example 28	Example 29	Example 30
Nypast 222B	8.3	10	12	12	17	16.5	5	5	5	10	16	14	14	10	10	4	8	8	8
Hercotac 1148	45.5	45.5	58	58	61	58	55	50	50	60	55	57.5	57.5	59.5	59.5	57.5	58.5	59.5	59.5
Escorez 2596																			
Huntsman RT2535	28.7	27																	
Huntsman RT2304	5	5					5									10	10		
Eastoflex 1003																			
Eastoflex 1060			9.5	9.5	5	5	10.5	20.5						10	10				10
Vestoplast 704																			
Vestoplast 508								20.5											19
EOD-01-06	12	12										8	8	8	8				
EOD-02-07			16	16	16	15	8	8	8		8					8	8		
EOD-02-15																			4
Kraton 1657			4																
Kraton 1652				4															
Tuffec SBBS-JT84P																			
Elvax 150					5.5				16										
Kraton D1112						5													
Engage 8407							16	16		29.5									
Engage 8401											20.5								13
Lotryl 35BA320													5						
Lotryl 28BA175															12				
Lotryl 7BA-01												20	15	12		15			
Irganox 1010	0.5	0.5	0.5	0.5	0.5	0.5	0.5	0.5	0.5	0.5	0.5	0.5	0.5	0.5	0.5	0.5	0.5	0.5	0.5
Epolene C18																			5
Orevac 9305																	10		
Exxelor VA1840																		5	
Brookfield viscosity @ 325°F (163°C)	11700 cP	10100 cP	7250 cP	6875 cP		4240 cP	10600 cP	12300 cP	8550 cP	11020 cP	11270 cP	5275 cP	4215 cP	5250 cP	4875 cP	6800	5450	19,450	4550
Herzog Softening Point			225°F	227°F			234°F	228°F				214°F	230°F	239°F	235°F				
Tensile Strength (psi)	84	80	138	150		102	110	150		83	154	165	165	109	94	231	177	118	170
Elongation (%)	94%	88%	>1000 %	>1000 %		>1000 %	>1000 %	>1000 %		>1000 %	900%	>1000 %	>1000 %	>1000 %	>1000 %	>1000 %	765%	>1000 %	>1000 %

*Example of an adhesive without a secondary polymer.

Nyplast 222B is a mineral oil with 47% naphthenics, 48% paraffinics and 5% aromatics from Nynas USA.

Hercotac 1148 is a C5/C9 hydrocarbon resin with a Softening Point of 94°C from Eastman Chemical Products.

5 Epolene C18 is a polyethylene wax treated with maleic anhydride from Eastman Chemical Products.

Vestoplast 508 is a butene-rich APAO from Degussa Corp. with a target viscosity of 80 Poise at 190°C.

10 Eastoflex 1003 is an high ethylene content APAO from Eastman Chemical Products with a target viscosity of 2.5 Poise at 190°C.

Eastoflex 1060 is a medium ethylene content APAO from Eastman with a target viscosity of 60 Poise at 190°C.

Lotryl 7BA01 is an ethylene butyl acrylate copolymer containing 7% butyl acrylate and a melt index of 1 from Atofina Chemicals Inc.

15 Lotryl 28BA175 is an ethylene butyl acrylate copolymer containing 28% butyl acrylate and a melt index of 175 from Atofina Chemicals Inc..

Lotryl 35BA320 is an ethylene butyl acrylate copolymer with 35% butyl acrylate and a melt index of 320. It is available from Atofina Chemicals Inc.

20 Lotryl 28BA175 is an ethylene butyl acrylate copolymer with 28% butyl acrylate and a melt index of 175. It is available from Atofina Chemicals Inc.

Orevac 9305 is an ethylene vinyl acetate/ maleic anhydride terpolymer available from Atofina Chemicals Inc.

EOD-01-06 is a metallocene catalyzed RCP polymer with a melt index of 7 and a DSC softening point of 112°C available from Atofina Chemicals Inc.

25 EOD-02-07 is a mRCP copolymer with a melt index of 50 and a DSC softening point of 112°C from Atofina Chemicals Inc.

Engage 8407 is a 30 melt index ethylene/octene copolymer with a density of 0.875 g/cc. It is available from DuPont Dow Elastomers.

30 Engage 8401 is a 30 melt index ethylene/octene copolymer with a density of 0.885 g/cc. It is available from DuPont Dow Elastomers.

Exxelor VA1840 (MAH functionalized Elastomeric copolymer) has an EPR backbone with "medium" Maleic anhydride content from ExxonMobil. It is semi-crystalline and has 27 MFR (g/10 min, 230°C/10kg).

5 Huntsman RT 2535 is a high ethylene content APAO from Huntsman Chemical Co. It has a viscosity range at 190°C is 28.00 to 42.00 Poise with a Softening Point range of 260 to 276°F (127 to 136°C).

Huntsman RT 2304 is an APAO from Huntsman Chemical Co. with a medium ethylene content. The viscosity range at 190°C is 3.5 to 5.5 Poise.

10 Vestoplast 704 is a propene-rich APAO from Degussa Corp. with a target viscosity of 35 Poise at 190°C.

Kraton G1657 is an styrene/ethylene-butylene/styrene block copolymer (SEBS) from Kraton Polymers with a 13/87 %, styrene/rubber ratio. It contains 30% diblock by weight.

15 Kraton G1652 is a styrene/ethylene-butylene/styrene (SEBS) block copolymer available from Kraton Polymers with a 30/70 % styrene/rubber ratio.

Tuftec SBBS-JT84P is a styrene/butadiene-butylene/styrene block copolymer containing 29% styrene from Asahi Rubber Co in Japan.

20 Elvax 150 is an ethylene/vinyl acetate (EVA) copolymer containing 33% vinyl acetate and having a melt index of 43. It is available from Dupont Chemical Co.

Kraton D1112P is a linear styrene/isoprene/styrene block copolymer available from Kraton Polymers. It has a 15/85%, styrene/rubber ratio and contains 38% diblock.

CLAIMS

We claim:

1. A hot melt adhesive composition comprising a blend of the following components:

(a) about 4% to 50% by weight of a random RCP copolymer of propylene and at least one α -olefin comonomer having the following
5 molecular structure:

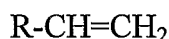

where R is hydrogen or a C₂ to C₁₀ alkyl group, and said α -olefin comprises about 1.5% by weight to about 20% by weight of the said RCP copolymer;

(b) about 20% to 65% by weight of a tackifier;

10 (c) about 0% to 60% by weight of an atactic poly- α -olefin (APAO) polymer;

(d) about 0% to 40% by weight of a plasticizer;

(e) about 0% to 40% by weight of a wax;

(f) about 0% to 3% by weight of a stabilizer;

15 (g) about 0% to 60% by weight of a filler; and

(h) about 0% to 40% by weight of a secondary polymer;

the components totaling 100% by weight of the composition.

2. The composition of claim 1 wherein said RCP copolymer has a density of about 0.88 g/cc to 0.905 g/cc and a melt flow rate of equal to or greater than 5 g/10min and an a melting point equal to or less than 145°C.

3. The composition of claim 2 wherein said RCP copolymer is an mRCP copolymer of propylene and at least one α -olefin prepared by using a metallocene catalyst system.

4. The composition of claim 1 wherein said APAO polymer has a density of about 0.85 g/cc to 0.89 g/cc and a glass transition temperature (T_g) of from about -5 to -40 °C and a weight average molecular weight (M_w) of from about 4,000 g/mol to about 150,000 g/mol.

5. The composition of claim 1 wherein the α -olefin comonomer is selected from the group consisting of ethylene, butene-1 and hexene-1.

6. The composition of claim 1 wherein the APAO polymer is a homopolymer or a copolymer of propylene and at least one α -olefin comonomer having the following molecular structure:

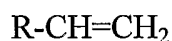

5 where R is hydrogen, or an alkyl or an aryl radical.

7. The composition of claim 6 wherein the α -olefin comonomer is selected from the group consisting of ethylene, butene-1 and hexene-1.

8. The composition of claim 1 wherein the tackifier is selected from the group consisting of aliphatic and cycloaliphatic hydrocarbon resins and their hydrogenated derivatives, aromatic and hydrogenated aromatic hydrocarbon resins, aromatically modified aliphatic or cycloaliphatic resins and their hydrogenated
5 derivatives, polyterpene and styrenated polyterpene resins.

9. The composition of claim 8 wherein the tackifier has a R&B softening point equal to or greater than 80 °C.

10. The composition of claim 9 wherein the tackifier is a C-5 aliphatic hydrocarbon resin.

11. The composition of claim 1 wherein the plasticizer is selected from the group consisting of mineral oil and liquid polybutene.

12. The composition of claim 11 wherein the mineral oil has less than 30% aromatic carbon atoms.

13. The composition of claim 1 wherein said wax is selected from the group consisting of petroleum waxes, low molecular weight polyethylene and polypropylene, synthetic waxes and polyolefin waxes.

14. The composition of claim 13 wherein the said wax is a low molecular weight polyethylene having a number average molecular weight of about 400 to about 6,000 g/mol.

15. The composition of claim 1 further including 0.1% to about 30% by weight of a surfactant.
16. The composition of claim 15 wherein the surfactant has an HLB of less than 15.
17. The composition of claim 15 wherein the surfactant is selected from the group consisting of fatty acid esters, nonionic ethoxylates and ethylene oxide/propylene oxide copolymers.
18. The composition of claim 1 wherein said filler is selected from the group consisting of talc, calcium carbonate, clay, silica, mica, wollastonite, feldspar, aluminum silicate, alumina, hydrated alumina, glass microsphere, ceramic microsphere, thermoplastic microsphere, baryte and wood flour.
19. The composition of claim 1 wherein the adhesive composition further includes a colorant.
20. The composition of claim 1 wherein said secondary polymer is a thermosetting polymer.
21. The composition of claim 1 wherein said secondary polymer is a thermoplastic polymer.
22. The composition of claim 1 wherein said secondary polymer is selected from the group consisting of ethylene acrylate, ethylene methacrylate, ethylene methyl acrylate, ethylene methyl methacrylate, an ethylene-styrene interpolymer, an ethylene acrylic acid, ethylene vinyl acetate, ethylene vinyl acetate
5 carbon monoxide, ethylene N-butyl acrylate carbon monoxide; polybutene-1
polymers; polyolefins, high and low density polyethylene, polyethylene blends,
chemically modified polyethylene, copolymers of ethylene and C₁ to C₁₀ mono- or
diunsaturated monomers, ethylene/octene copolymers, ethylene/hexene copolymers,
ethylene/butene copolymers, polyamides, polybutadiene rubber, polyesters,
10 polyethylene terephthalate, polybutylene terephthalate, thermoplastic polycarbonates,
poly-alpha-olefins, atactic polypropylene, isotactic polypropylene, syndiotactic
polypropylene, isotactic random copolymers, metallocene catalyzed isotactic random

15 copolymers, thermoplastic polyacrylamides, polyacrylonitrile, copolymers of acrylonitrile and other monomers such as butadiene or styrene, polymethyl pentene, polyphenylene sulfide, aromatic polyurethanes; styrene-acrylonitrile, acrylonitrile-butadiene-styrene, styrene-butadiene rubbers, acrylonitrile-butadiene-styrene elastomers; A-B, A-B-A, A-(B-A)_n-B, (A-B)_n-Y block copolymers wherein the A block comprises a polyvinyl aromatic block such as polystyrene, the B block comprises a rubbery midblock which can be polyisoprene, and optionally
20 hydrogenated, such as polybutadiene, Y comprises a multivalent compound, and n is an integer of at least 3, polyvinyl alcohols and copolymers thereof, polyvinyl acetate and random copolymers thereof, and polyvinyl aromatic-rubber block copolymers.

23. The composition of claim 1 wherein said secondary polymer is an ethylene butyl acrylate copolymer.

24. The composition of claim 1 wherein said secondary polymer is an ethylene/octene copolymer.

25. The composition of claim 1 wherein said secondary polymer is an ethylene vinyl acetate/maleic anhydride terpolymer.

26. The composition of claim 1 wherein said secondary polymer is a styrene/ethylene-butylene/styrene block copolymer.

27. The composition of claim 1 wherein said secondary polymer is a styrene/butadiene-butylene/styrene block copolymer.

28. The composition of claim 1 wherein said secondary polymer is an ethylene/vinyl acetate copolymer.

29. The composition of claim 1 wherein said secondary polymer is a styrene/isoprene/styrene block copolymer.

30. The composition of claim 1 wherein said secondary polymer functions to increase or decrease elasticity of the adhesive composition.

31. The composition of claim 1 wherein said secondary polymer functions to increase or decrease adhesion of the adhesive composition.

32. The composition of claim 1 wherein said secondary polymer functions to increase or decrease low temperature resistance of the adhesive composition.
33. The composition of claim 1 wherein said secondary polymer functions to increase or decrease high temperature resistance of the adhesive composition.
34. The composition of claim 1 wherein said secondary polymer functions to increase or decrease creep resistance of the adhesive composition.
35. The composition of claim 1 wherein said secondary polymer functions to increase or decrease cohesive strength of the adhesive composition.
36. The composition of claim 1 wherein said secondary polymer functions to increase or decrease pressure sensitivity of the adhesive composition.
37. A corrugated box article bonded with the adhesive composition of claim 1.
38. A laminate comprising a first layer of nonwoven material, a second layer of nonwoven material, and a plurality of elastic strands disposed between said first and second nonwoven layers, bonded together with the adhesive composition of claim 1.
39. A laminate comprising a first layer of nonwoven material, a second layer of film material, and a plurality of elastic strands disposed between said first and second layers, bonded together with the adhesive composition of claim 1.
40. The laminate of claim 39 where the said film comprises a polyethylene film, a polypropylene film, an ethylene-propylene copolymer film or a polyolefin coated cloth-like nonwoven material.
41. A laminate comprising a first layer of nonwoven material bonded to a second layer of film material with the adhesive composition of claim 1.
42. The laminate of claim 41 where the said film material comprises a polyethylene film, a polypropylene film, an ethylene-propylene copolymer film or a polyolefin coated cloth-like nonwoven material.

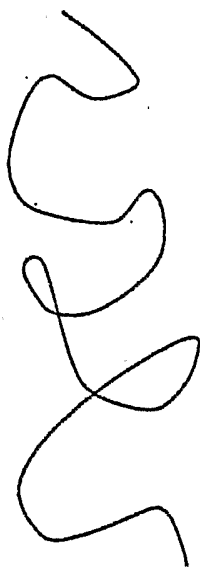

FIG. 1(a)

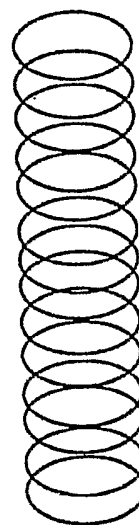

FIG. 1(b)

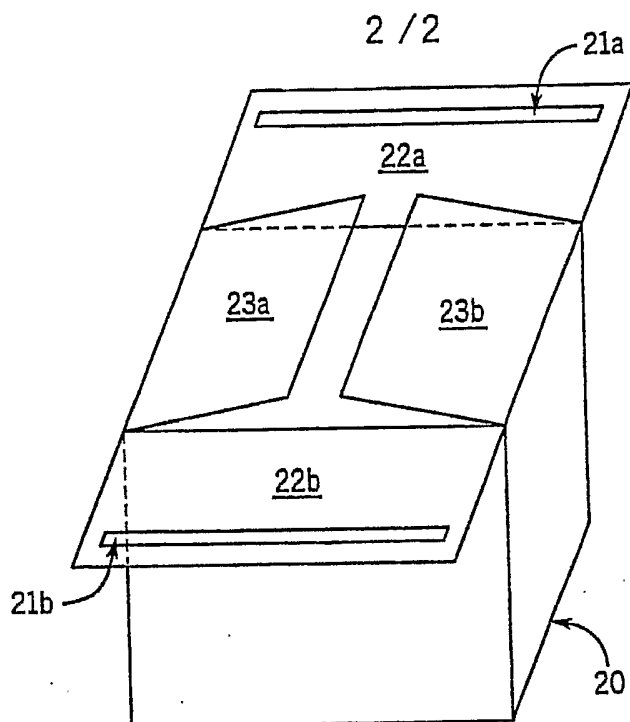

FIG. 2

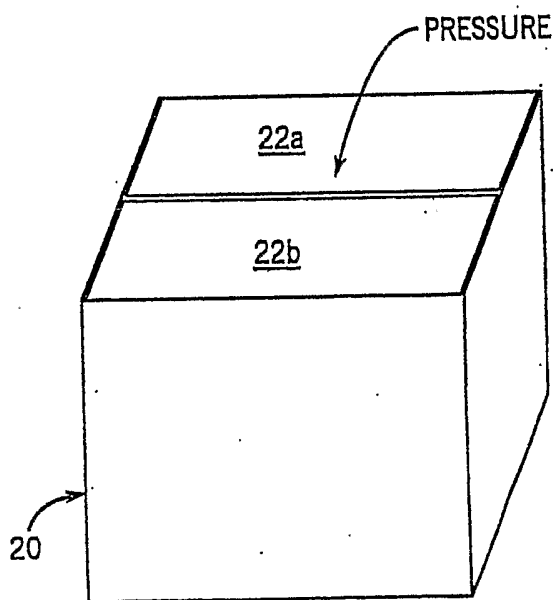

FIG. 3

INTERNATIONAL SEARCH REPORT

International Application No

PCT/US 03/33860

A. CLASSIFICATION OF SUBJECT MATTER
IPC 7 C09J123/14

According to International Patent Classification (IPC) or to both national classification and IPC

B. FIELDS SEARCHED

Minimum documentation searched (classification system followed by classification symbols)
IPC 7 C09J

Documentation searched other than minimum documentation to the extent that such documents are included in the fields searched

Electronic data base consulted during the international search (name of data base and, where practical, search terms used)

EPO-Internal, WPI Data

C. DOCUMENTS CONSIDERED TO BE RELEVANT

Category °	Citation of document, with indication, where appropriate, of the relevant passages	Relevant to claim No.
P,X	WO 03 033612 A (BOSTIK FINDLEY INC) 24 April 2003 (2003-04-24) page 21, line 16 - line 23 ---	1-19, 37-42
X	WO 01 53408 A (ATO FINDLEY INC) 26 July 2001 (2001-07-26) page 10, line 25 - line 6 ---	1-19, 37-42
X	WO 01 46277 A (EXXON CHEMICAL PATENTS INC) 28 June 2001 (2001-06-28) table 3 ---	1-42
X	WO 94 04625 A (EXXON CHEMICAL PATENTS INC) 3 March 1994 (1994-03-03) table 1 ---	1
	-/--	

Further documents are listed in the continuation of box C.

Patent family members are listed in annex.

° Special categories of cited documents :

- "A" document defining the general state of the art which is not considered to be of particular relevance
- "E" earlier document but published on or after the international filing date
- "L" document which may throw doubts on priority claim(s) or which is cited to establish the publication date of another citation or other special reason (as specified)
- "O" document referring to an oral disclosure, use, exhibition or other means
- "P" document published prior to the international filing date but later than the priority date claimed

- "T" later document published after the international filing date or priority date and not in conflict with the application but cited to understand the principle or theory underlying the invention
- "X" document of particular relevance; the claimed invention cannot be considered novel or cannot be considered to involve an inventive step when the document is taken alone
- "Y" document of particular relevance; the claimed invention cannot be considered to involve an inventive step when the document is combined with one or more other such documents, such combination being obvious to a person skilled in the art.
- "&" document member of the same patent family

Date of the actual completion of the international search

19 February 2004

Date of mailing of the international search report

03/03/2004

Name and mailing address of the ISA

European Patent Office, P.B. 5818 Patentlaan 2
NL - 2280 HV Rijswijk
Tel. (+31-70) 340-2040, Tx. 31 651 epo nl,
Fax: (+31-70) 340-3016

Authorized officer

Schmidt, H

INTERNATIONAL SEARCH REPORT

International Application No
PCT/US 03/33860

C.(Continuation) DOCUMENTS CONSIDERED TO BE RELEVANT		
Category °	Citation of document, with indication, where appropriate, of the relevant passages	Relevant to claim No.
X	WO 01 81493 A (EXXONMOBIL CHEM PATENTS INC) 1 November 2001 (2001-11-01) tables 1,2 ----	1
X	US 2002/007033 A1 (A.C.KARA<NDINOS ET AL) 17 January 2002 (2002-01-17) table 1 ----	1
X,P	EP 1 344 642 A (MITSUI CHEMICALS INC) 17 September 2003 (2003-09-17) example D2 -----	1-42

INTERNATIONAL SEARCH REPORT

International Application No

PCT/US 03/33860

Patent document cited in search report		Publication date	Patent family member(s)	Publication date
WO 03033612	A	24-04-2003	US 2003096896 A1 WO 03033612 A1	22-05-2003 24-04-2003
WO 0153408	A	26-07-2001	US 6329468 B1 AU 2796801 A CA 2398000 A1 CN 1419585 T EP 1252231 A1 JP 2003533551 T WO 0153408 A1	11-12-2001 31-07-2001 26-07-2001 21-05-2003 30-10-2002 11-11-2003 26-07-2001
WO 0146277	A	28-06-2001	AU 2289101 A AU 2592601 A BR 0016618 A CA 2395532 A1 CA 2414498 A1 CN 1433451 T EP 1263815 A2 EP 1263909 A2 JP 2003518171 T WO 0146277 A2 WO 0146278 A2 US 2002019507 A1 US 2002007033 A1 US 2002039623 A1 CA 2388850 A1 EP 1290100 A1 WO 0181493 A1	03-07-2001 03-07-2001 03-09-2002 28-06-2001 08-06-2001 30-07-2003 11-12-2002 11-12-2002 03-06-2003 28-06-2001 28-06-2001 14-02-2002 17-01-2002 04-04-2002 01-11-2001 12-03-2003 01-11-2001
WO 9404625	A	03-03-1994	US 5317070 A CA 2143124 A1 DE 69321478 D1 DE 69321478 T2 EP 0656925 A1 ES 2123659 T3 JP 8500369 T WO 9404625 A1	31-05-1994 03-03-1994 12-11-1998 15-04-1999 14-06-1995 16-01-1999 16-01-1996 03-03-1994
WO 0181493	A	01-11-2001	US 2002019507 A1 US 2002007033 A1 AU 2289101 A AU 2592601 A BR 0016618 A CA 2388850 A1 CA 2395532 A1 CA 2414498 A1 CN 1433451 T EP 1263815 A2 EP 1263909 A2 EP 1290100 A1 JP 2003518171 T WO 0146277 A2 WO 0146278 A2 WO 0181493 A1 US 2002039623 A1	14-02-2002 17-01-2002 03-07-2001 03-07-2001 03-09-2002 01-11-2001 28-06-2001 08-06-2001 30-07-2003 11-12-2002 11-12-2002 12-03-2003 03-06-2003 28-06-2001 28-06-2001 01-11-2001 04-04-2002
US 2002007033	A1	17-01-2002	CA 2388850 A1 EP 1290100 A1	01-11-2001 12-03-2003

INTERNATIONAL SEARCH REPORT

International Application No

PCT/US 03/33860

Patent document cited in search report	Publication date	Patent family member(s)	Publication date
US 2002007033	A1	WO 0181493 A1	01-11-2001
		US 2002039623 A1	04-04-2002
		AU 2289101 A	03-07-2001
		AU 2592601 A	03-07-2001
		BR 0016618 A	03-09-2002
		CA 2395532 A1	28-06-2001
		CA 2414498 A1	08-06-2001
		CN 1433451 T	30-07-2003
		EP 1263815 A2	11-12-2002
		EP 1263909 A2	11-12-2002
		JP 2003518171 T	03-06-2003
		WO 0146277 A2	28-06-2001
		WO 0146278 A2	28-06-2001
		US 2002019507 A1	14-02-2002
<hr/>			
EP 1344642	A	CN 1445322 A	01-10-2003
		EP 1344642 A2	17-09-2003
<hr/>			