



(11) (21) (C) **2,309,892**
(22) 1995/06/28
(43) 1996/01/11
(45) 2001/03/20
(62) 2,191,190
(22) 1995/06/28

(72) VENTRUDO, BRIAN F., CA

(72) ROGERS, GRANT, CA

(73) SDL, INC., US

(51) Int.Cl.⁷ H01S 3/067, H01S 3/091

(30) 1994/06/28 (08/267,785) US

(54) **DIODE LASER STABILISEE PAR UN RESEAU SUR UN FIBRE**

(54) **FIBRE GRATING STABILIZED DIODE LASER**

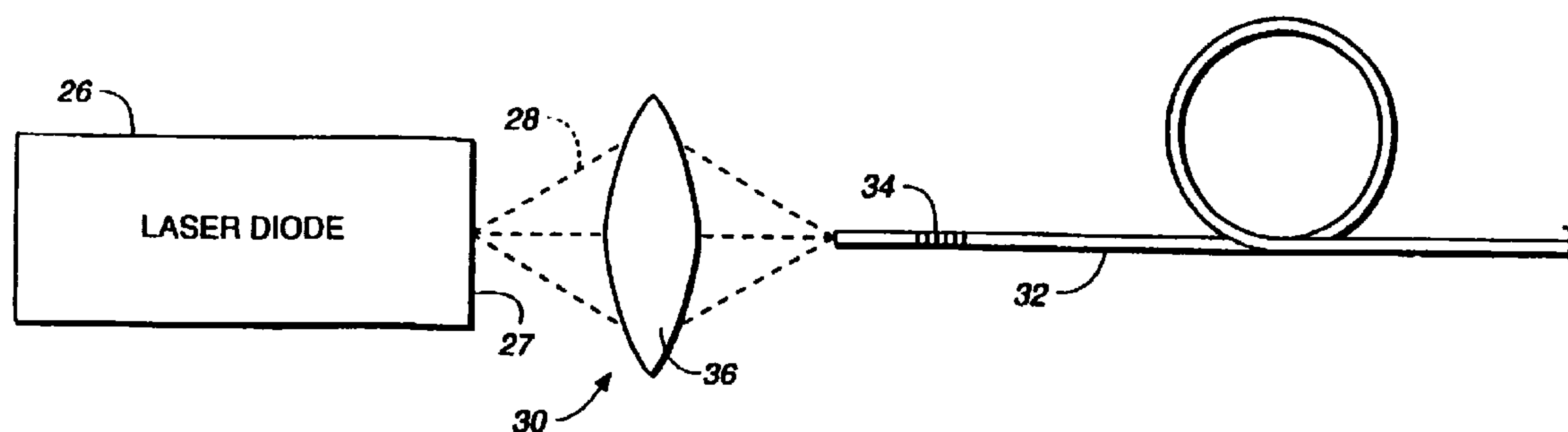

(57) A fibre Bragg grating (34) is used to stabilize the intensity and frequency fluctuations of a diode laser (26). The diode laser is connected with an opto-mechanical apparatus to the fibre which contains the grating. The grating is formed in the guided-mode region of the optical fibre (32). The wavelength of maximum grating reflectivity is selected to lie near the maximum of the diode laser gain bandwidth. The output facet of the diode laser has a reflectivity approximately equal to or greater than that of the fibre Bragg grating. The magnitude and bandwidth of the grating reflectivity stabilizes the diode laser output without appreciably reducing the optical output power from the end of the fibre. The bandwidth of the optical spectrum of the diode laser is selected depending on the distance of the grating from the diode laser.





INTERNATIONAL APPLICATION PUBLISHED UNDER THE PATENT COOPERATION TREATY (PCT)

(51) International Patent Classification ⁶ : H01S 3/085, 3/06	A1	(11) International Publication Number: WO 96/00997 (43) International Publication Date: 11 January 1996 (11.01.96)
<p>(21) International Application Number: PCT/CA95/00391</p> <p>(22) International Filing Date: 28 June 1995 (28.06.95)</p> <p>(30) Priority Data: 08/267,785 28 June 1994 (28.06.94) US 08/408,002 21 March 1995 (21.03.95) US</p> <p>(71) Applicant: SEASTAR OPTICS INC. [CA/CA]; 2045 Mills Road, Sidney, British Columbia V8L 3S8 (CA).</p> <p>(72) Inventors: VENTRUDO, Brian, F.; 2636 Cedar Hill Road, Victoria, British Columbia V8T 3H2 (CA). ROGERS, Grant; 3248 Wicklow Street, Victoria, British Columbia V8X 1C9 (CA).</p> <p>(74) Agent: SMITH, Paul; Suite 1050, 409 Granville Street, Vancouver, British Columbia V6C 1T2 (CA).</p>	<p>(81) Designated States: AM, AT, AU, BB, BG, BR, BY, CA, CH, CN, CZ, DE, DK, EE, ES, FI, GB, GE, HU, IS, JP, KE, KG, KP, KR, KZ, LK, LR, LT, LU, LV, MD, MG, MN, MW, MX, NO, NZ, PL, PT, RO, RU, SD, SE, SG, SI, SK, TJ, TT, UA, UZ, VN, European patent (AT, BE, CH, DE, DK, ES, FR, GB, GR, IE, IT, LU, MC, NL, PT, SE), OAPI patent (BF, BJ, CF, CG, CI, CM, GA, GN, ML, MR, NE, SN, TD, TG), ARIPO patent (KE, MW, SD, SZ, UG).</p> <p>Published With international search report. Before the expiration of the time limit for amending the claims and to be republished in the event of the receipt of amendments.</p> <div data-bbox="1470 1009 1974 1365" style="border: 1px dashed black; padding: 5px; text-align: center;"> <p>DEPOSITED</p> <p>JAN 25 1996</p> <p>WIPO</p> </div>	
(54) Title: FIBRE GRATING STABILIZED DIODE LASER		

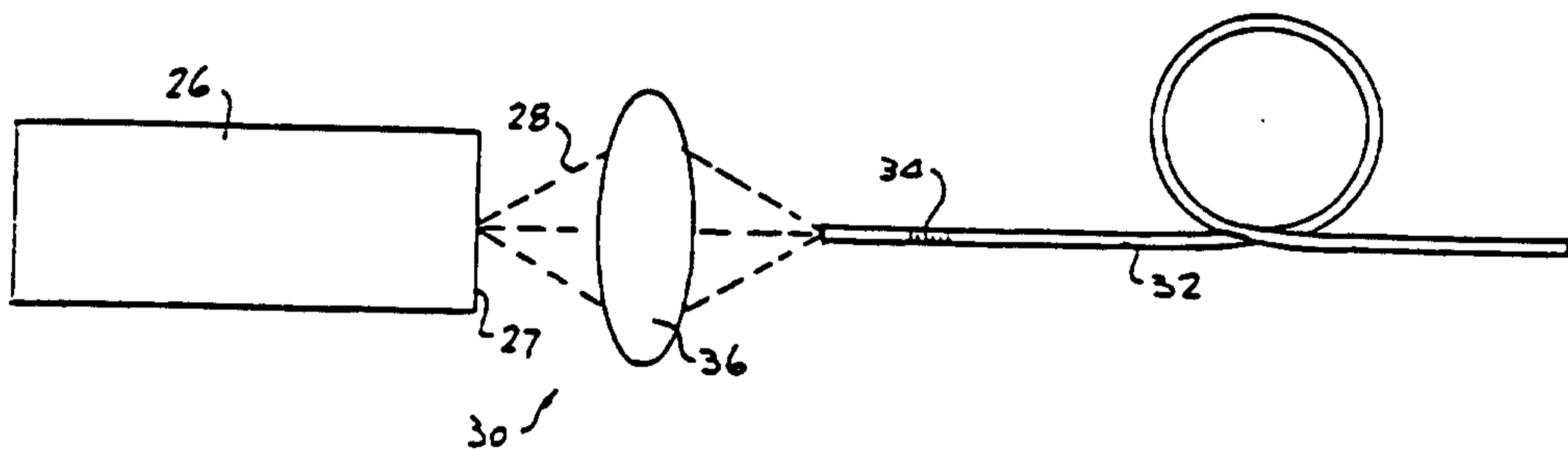

(57) Abstract

A fibre Bragg grating (34) is used to stabilize the intensity and frequency fluctuations of a diode laser (26). The diode laser is connected with an opto-mechanical apparatus to the fibre which contains the grating. The grating is formed in the guided-mode region of the optical fibre (32). The wavelength of maximum grating reflectivity is selected to lie near the maximum of the diode laser gain bandwidth. The output facet of the diode laser has a reflectivity approximately equal to or greater than that of the fibre Bragg grating. The magnitude and bandwidth of the grating reflectivity stabilizes the diode laser output without appreciably reducing the optical output power from the end of the fibre. The bandwidth of the optical spectrum of the diode laser is selected depending on the distance of the grating from the diode laser.

TITLE OF THE INVENTION

FIBRE GRATING STABILIZED DIODE LASER

CROSS REFERENCE TO OTHER APPLICATIONS

This application is a division of
Serial No. 2,191,190 filed June 28, 1995.

TECHNICAL FIELD

5 The present invention is a stabilized laser source
which provides narrow-bandwidth high-power optical
radiation with stable intensity and wavelength suitable,
for example, for optically pumping solid-state fibre
amplifiers or lasers such as fibre lasers.

10

BACKGROUND ART

Optical fibre amplifiers and lasers have rapidly
become important components of optical communications
systems. Optical fibre amplifiers are used to intensify
optical signals that are attenuated along the fibre-optic
15 communication path. They have replaced cumbersome
electrical repeaters in fibre-optic communication links
allowing true all-fibre optical communications systems to
be realized. Similarly, optical fibre lasers have been
proposed to generate an optical carrier for fibre-optic
20 communications systems. These lasers can be externally
modulated or mode locked, and in some cases are an
alternative to diode lasers as sources of high-power
light in fibre optic communications systems.

Both fibre amplifiers and lasers operate on similar
25 principles. The silica glass in the guided-wave portion
of the optical fibre is doped with ions of a rare-earth
element such as, for example, erbium. The energy
structure of the erbium ions is such that signal light
with wavelength of approximately 1530-1565 nm can be
30 amplified in the fibre if the population of the excited

- 2 -

states of the erbium ions is such that rate of stimulated emission exceeds that of spontaneous emission and absorption. In such a circumstance, light within the gain bandwidth entering the optical fibre will experience net gain, and will exit the fibre with greater power. If a mechanism is established to recirculate this amplified signal in the fibre, for example by placing the appropriate reflectors at the ends of the fibre, then laser action can occur in the fibre if the net gain equals the loss of the light within some optical bandwidth. In either case, it is crucial to excite the erbium ions into the proper excited state for gain to occur. This can be accomplished by exciting (pumping) the erbium ions with light near wavelengths of 980 nm, which is most conveniently provided by a high-power diode laser that is coupled into the guided-wave portion of the optical fibre. The relatively small cross-sectional area of this portion helps to ensure high intensity and therefore allows appreciable gain of the signal wavelengths. However, those skilled in the art will appreciate that the properties of the signal produced by such an amplifier or laser will depend to a large extent on the properties of the diode laser used to pump the fibre itself.

In a practical system, the diode lasers are permanently and robustly connected with an optomechanical apparatus to a length of undoped optical fibre which in turn is connected to the doped fibre in the optical amplifier or laser. The assembly consisting of the diode laser, optomechanical apparatus and optical fibre is called a pigtailed diode laser. Presently, many pigtailed diode lasers have undesirable characteristics such as wavelength and intensity instabilities that create noise in the pumped system. The most troublesome sources of diode laser noise in 980 nm diode lasers are mode-hopping noise and wavelength fluctuations that are

- 3 -

caused by unwanted variable optical feedback into the diode laser or changes in temperature or injection current. The noise is especially detrimental in fibre amplifiers because it increases errors in the amplified optical communication signal and detracts from the practicality of these devices.

There are many techniques to reduce the effect of such diode laser noise. An example is an active electrical system that detects the variation in output of the fibre amplifier caused by a fluctuation in the diode laser characteristics and feeds back a signal into the laser diode at the correct phase to reduce the laser fluctuation. Unfortunately, this technique adds cost and complexity to the amplifier. It is preferable to employ a passive method of reducing diode laser fluctuations. An attractive solution is to feed back into the pump diode laser a portion of its own light. These lasers are very sensitive to optical feedback, and if such feedback is properly controlled, improved laser operation can result. Feedback is usually provided by an external reflector such as a mirror or diffraction grating, and external optical elements such as lenses are required to manipulate and guide the light out of and back into the diode laser cavity. Although the external optics and reflectors can often be quite compact, it is difficult and expensive to align such a system, and the mechanical and thermal stability can often be inadequate for use in fibre amplifiers and lasers. A more rugged technique for control of diode laser characteristics is required.

30

SUMMARY OF THE INVENTION

The present invention uses a fibre Bragg grating in a pigtailed diode laser to provide optical feedback into the cavity of a diode laser, thereby locking the

frequency of the diode laser to that of the fibre grating, and reducing the longitudinal mode-hopping noise of the laser. A fibre Bragg grating is a periodic structure of refractive index variations in or near the guided-mode portion of the optical fibre that can reflect light of a certain wavelength propagating along the fibre. The reflected light propagates in the fibre in a direction opposite to that of the incident light. If a diode laser is pigtailed to a fibre containing a fibre Bragg grating, and if the centre of the grating bandwidth is within the gain bandwidth of the laser, then the optical spectrum of the diode laser will be affected. The exact effect depends on such parameters as the magnitude and bandwidth of the grating reflectivity, the centre wavelength of the grating relative to the laser, the magnitude of separation between the laser and grating, and the magnitude of injection current into the diode laser. In many cases, the laser characteristics can be improved for a given application.

The apparatus according to the invention is formed by a diode laser, means for focusing the emission of the laser into a length of optical fibre, and a fibre grating formed in or near the guided wave portion of the optical fibre.

According to an object of an aspect of the present invention, there is provided an optical feedback system comprising:

a gain medium having a first optical cavity and having an output;

at least a first reflecting component in said first optical cavity and having a first reflectivity level;

an optical fibre optically coupled to said first cavity;

a reflective element accompanying said optical fibre, said reflective element having a

4a

supplemental reflectivity level for reflecting a portion of said output over a narrow band of wavelengths back into said first cavity;

5 said supplemental reflectivity level approximately equal to or less than said first reflectivity level.

According to an object of an aspect of the present invention, there is provided an apparatus for generating a
10 stable laser source comprising:

a laser source having a lasing cavity and a light beam output at a laser facet,

said laser facet also providing a level of partial reflectivity for a portion of said light

15 beam in said laser cavity for optical feedback therein, said light beam output

comprising a wavelength band of light dependent upon the instantaneous

operating characteristics of said laser source;

20 an optical fibre having an input end coupled to said laser source to receive

said light beam into said fibre;

a grating formed in said optical fibre, said grating having a reflectivity band for

25 partially reflecting selected wavelengths defined by said reflectivity band back

into said laser cavity;

the reflectivity level of said optical fibre grating being approximately equal to or less

30 than the reflectivity level of said laser source facet.

According to another object of an aspect of the present invention, there is provided an apparatus for generating a stable laser source comprising:

35 a semiconductor laser having a first optical cavity and having an output;

4b

at least a first reflecting component in said first optical cavity and having a first reflectivity level;

5 an optical fibre optically coupled to said first cavity;

a reflective element accompanying said optical fibre and together therewith forming a second optical cavity;

10 said reflective element having a supplemental reflectivity level for reflecting a portion of said output over a narrow band of wavelengths back into said first cavity;

15 said supplemental reflectivity level approximately equal to or less than said first reflectivity level;

said semiconductor laser having a gain band at least a portion of which overlaps with said reflective element reflectivity band;

20 said fibre grating locking the output from said semiconductor laser to a fixed wavelength of the grating around which are established a plurality of multi-longitudinal modes in said second optical cavity collapsing the coherence operation of said semiconductor laser resulting in a reduction of the magnitude of intensity noise in laser operation absent said
25 supplemental reflectivity level.

According to another object of an aspect of the present invention, there is provided an apparatus for generating a stable laser source comprising:

a gain medium having a first optical cavity;

30 a first reflecting component at one end of in said first optical cavity and having a first reflectivity level for reflecting a portion of propagating light in said first optical cavity back into said cavity, said facet also providing a light output;

35

4c

an optical fibre optically coupled to said first cavity to receive said light output;
a second reflecting component accompanying said optical fibre, said second reflecting component having a second reflectivity level for reflecting a portion of said output over a narrow band of wavelengths back into said first optical cavity;
said second reflectivity level approximately equal to or less than said first reflectivity level;
second reflecting component positioned in said optical fibre a distance from said first optical cavity sufficient to induce incoherent feedback from constraining a gain medium to function in a multiple longitudinal mode operation suppressing the magnitude of intensity noise from the gain medium.

According to another object of an aspect of the present invention, there is provided a stabilized laser source comprising:

a laser source having an optical cavity and providing an output at a facet;
said facet having a first reflectivity level;
an optical fibre optically coupled to the laser source optical cavity;
a second reflective element in said optical fibre, said reflective element having a second reflectivity level for reflecting a portion of the laser source output over a narrow band of wavelengths back into the laser source optical cavity;
characterized in that
said second reflective element is positioned along said optical fibre from the laser source facet a distance sufficiently far from the laser source provide incoherent feedback to the laser source including coherence collapse operation in the laser source.

35

BRIEF DESCRIPTION OF THE DRAWINGS

The preferred embodiment of the invention will be described by reference to the drawings thereof wherein:

5 Figure 1 is a schematic representation of a pigtailed diode laser associated with a fibre amplifier according to the prior art.

Figure 2 is a schematic representation of a pigtailed diode laser according to the invention.

10 Figure 3 is a graph comparing the output spectrum of a prior art pigtailed diode laser and of a pigtailed diode laser according to the invention.

BEST MODE FOR CARRYING OUT THE INVENTION

15

Fig. 1 represents a fibre amplifier 10 including a pigtailed diode laser according to the prior art. Optical fibre 14 is doped with erbium (indicated by numerals 16) to provide amplifying effect and is coupled to undoped fibre 13. 20 The amplifying effect may be achieved by exciting the erbium atoms with light at about 980 nm. This is achieved by coupling a 980 nm light source to the transmission light (at 1550 nm) from the transmission fibre 5 by means of an optoelectronic coupler 18.

25 The 980 nm light source is provided in the prior art by a pigtailed laser diode 20 consisting of a laser diode 22 coupled by lens 23 to undoped fibre 24. The

limitations of prior art pigtailed laser diodes have been discussed above.

Fig. 2 illustrates a pigtailed laser diode according to the preferred embodiment of the invention. Diode laser 26 emits radiation in a single-spatial mode, and is typically fabricated with a quantum well epitaxial structure or index guided structure from InGaAs semiconductor material. The diode laser is most conveniently pumped by current injection. Diode lasers with the necessary characteristics are commercially available.

The diode laser 26 is configured to emit radiation primarily from the front facet 27. The divergent laser emission 28 is directed with focusing system 30 into the guided-mode portion of a length of optical fibre 32, containing an intra-core fibre Bragg grating 34. The focusing system of the preferred embodiment consists of a lensing system represented as numeral 36 to focus the laser diode output into the fibre 32. Alternatively, the fibre can be placed in such proximity to the diode laser that a substantial fraction of the emitted light is collected by the fibre.

The optical fibre 32 is typically fabricated from silica glass containing trace dopants to improve the light guiding characteristics of the fibre. The fibre grating 34 that provides optical feedback to the diode laser can be etched near the guided-mode portion of the fibre 34 using lithography techniques, or more commonly, can be created by exposing the fibre to a pattern of periodic intensity variation of high fluence ultraviolet light. If the latter technique is employed to fabricate the grating, it is convenient if the fibre core has a concentration of germanium to render the core sensitive to the ultraviolet light that forms the grating. The

- 7 -

fibre 34 may be one that sustain a single or multiple spatial modes at the wavelength of emission of the diode laser.

5 The fibre grating 34 is selected to have maximum
reflectivity within 10 nm of the diode laser emission
wavelength, and the reflectivity is similar to that of
the exit facet of the diode laser. The bandwidth of the
grating reflectivity is typically 0.05 nm to 1 nm, but
can be up to 2 nm. The system can operate successfully
10 when the grating 34 and the laser diode 26 are separated
by a few hundred micrometers to several kilometres
provided the amount of optical feedback into the laser
remains greater than a certain magnitude. Using such a
configuration, the diode laser has substantially improved
15 characteristics suitable for pumping solid-state
amplifiers or lasers.

The light captured by the fibre 34 would normally
propagate down a length of the fibre indefinitely,
limited only by the fibre loss characteristics. The
20 fibre Bragg grating 34 is fabricated within the guided
mode portion or core of this length of fibre. The
grating is fabricated such that the wavelength of its
maximum reflection is within the gain bandwidth of the
diode laser. This grating reflects a fraction of the
25 diode laser emission light back through the fibre and the
focusing system into the diode laser. The remainder of
the light output passes through the fibre grating and
down the remaining length of fibre.

The effect of the fibre grating on the
30 characteristics of the diode laser optical output is
explained by considering the wavelength-dependent loss in
the coupled cavity formed by the fibre grating. Those
skilled in the art will appreciate that the optical
feedback from the fibre grating effectively reduces the

loss from the laser cavity of light within the bandwidth of the fibre grating. It is well known that the laser can operate preferentially near the wavelength of lowest loss, hence the wavelength of the diode laser can be

5 shifted from its free running value to the wavelength of the fibre grating. This can occur if the wavelength of the fibre grating is within the gain bandwidth of the diode laser, provided the magnitude of reflectivity from the grating is sufficient.

10 The behaviour of the diode laser under conditions of optical feedback is complicated by the effect of the diode laser cavity itself, which is formed by the end facets of the semiconductor chip. In the preferred embodiment of the invention, the reflectivity of the

15 grating as well as its wavelength are selected such that the broadband feedback from the diode laser cavity is greater than the feedback from the fibre grating. In this circumstance, the feedback from the fibre grating acts as a perturbation of the coherent electric field

20 formed in the diode laser cavity. This perturbation acts to break the coherence of the diode laser emission, thus broadening the bandwidth of the emission by several orders of magnitude, resulting in a spectral distribution as shown in curve A of Fig. 3. The fibre Bragg grating

25 effectively locks the diode cavity output to the fixed wavelength of the grating and centres the external cavity multi-longitudinal modes around that wavelength. The presence of the multi-longitudinal modes reduces the magnitude of mode-hopping noise in the diode laser. This

30 is termed coherence collapse of the diode laser. In addition, the centre wavelength of emission remains near the wavelength of maximum reflection from the fibre grating. The diode laser is thus constrained to operate within the grating bandwidth, so that large fluctuations

35 in wavelength of the diode laser caused by changes in temperature or current are eliminated. Additionally, the

- 9 -

laser is not perturbed by extraneous optical feedback from reflective components located beyond the fibre grating, provided the extraneous feedback is less than that provided by the fibre grating.

5 A diode laser in accordance with the present invention does not undergo transitions of single longitudinal laser cavity modes as are observed in free-running diode laser. Such transitions cause large intensity fluctuations in the diode laser output caused
10 by competition between two modes during the transition. These mode transitions are caused by changes in laser injection current or temperature, for example, and are detrimental to the operation of an optical amplifier or fibre laser. The optical output of the invention
15 consists of twenty or more longitudinal modes of the external cavity. Although the partitioning of optical power between the modes may change, there is much less fluctuation in laser intensity compared to that of a single mode, free-running diode laser.

20 The output power from the end of the fibre of the diode laser system is only slightly affected by the presence of the grating in the fibre. For weakly reflecting gratings, the output power from the fibre is reduced approximately by $(1-R_g)$, where R_g is the maximum
25 reflectivity of the grating. The injection current at laser threshold is slightly reduced by the presence of the grating. This effect increases the output power from the fibre and counteracts the aforementioned reduction of power.

30 The scope of the invention comprises a system in which the fibre grating is an arbitrary length from the diode laser. However, the magnitude of this length affects the operation of the diode laser. To ensure the maintenance of the coherence collapse of the laser

- 10 -

emission, the fibre grating is located at a sufficient optical distance from the front facet of the diode laser. This distance must be much longer than the coherence length of the diode laser under the prescribed conditions of optical feedback, so that optical feedback from the fibre grating remains incoherent, thus assuring the laser remains in a state of coherence collapse. If the grating is placed within a few centimetres or less of the diode laser, then the feedback from the fibre grating may be coherent with the electric field inside the laser cavity, and very narrow linewidth operation of the diode laser will result. Such emission is very useful for some applications but is much less stable for the application of pumping fibre amplifiers or lasers because of the onset of laser cavity-mode transition noise when the laser operating characteristics change. In addition, there are still transitions from coherent to incoherent operation of the diode laser which cause intensity fluctuations which are detrimental to the operation of optical fibre amplifiers and lasers.

In some applications, it is preferable to avoid the instabilities in the laser that can be caused by random and unpredictable states of polarization of the reflective light in the optical fibre. These changes are a result of random birefringence in the fibre caused by bending or by random stress induced in the fibre when it is manufactured. Accordingly in such circumstance, it is desirable to use optical fibre that can maintain the state of polarization of light propagating down the fibre. Such fibre has a relatively large amount of controlled, stress-induced birefringence produced near the guided-mode portion upon manufacture. This high-birefringence, or polarization-maintaining optical fibre, is commercially available. Further stress that is induced by bending such fibre is considerably less than the controlled intrinsic birefringence; hence the state

- 11 -

of polarization of the light propagating along the
guided-mode portion of the fibre is maintained. Although
it is more difficult to characterize such gratings in
polarization-maintaining fibre than in low birefringent
5 optical fibre, fibre gratings have been fabricated in
several commercially available polarization-maintaining
optical fibres and such fibre is easily incorporated into
the pigtailed diode laser. In the preferred embodiment,
Panda™ fibre from Fujikura Ltd. was used for fibre 14. A
10 Bragg fibre grating was formed in the Panda fibre and was
used with good results.

In the preferred embodiment of the invention, a
strained-layer InGaAs multi-quantum well diode laser is
coupled to the optical fibre with an aspheric lens
15 systems with efficiency of 60%. The laser emits light at
965-1160 nm, typically. The fibre grating has a
reflection bandwidth of 0.2-0.3 nm and a peak
reflectivity of approximately 3%. Accordingly, the
effective reflectivity R_{eff} seen by the fibre grating is
20 in general

$$R_{eff} = \eta^2 R_g$$

where η is the coupling efficiency of light from the
solitary diode laser into the optical fibre, and R_g is the
maximum reflectivity of the fibre grating. For the
25 specified values, for example, $(0.6)^2(3\%) = 1.08\%$. This
compares to the front facet of the diode laser, which has
a nominal reflectivity of 4%. This level of optical
feedback is sufficient to maintain the coherence collapse
of the diode laser while allowing sufficient light to
30 pass through the fibre grating, thus maximizing the
available power. The wavelength of the grating
reflectivity nominally lies within 10 nm of the
wavelength of the diode laser. The grating is 1-2 mm in
length. To ensure the maintenance of the coherence
35 collapse of the laser emission, the fibre grating is

- 12 -

located at least 50 cm from the front facet of the diode laser. If it is desirable to maintain the coherence of the laser system, the fibre grating should be located as close as possible to the exit facet of the diode laser, and certainly not more than a few centimetres away.

The output power from the optical fibre in the preferred embodiment is at most reduced by a few percent. For a 150 Mw diode laser pigtailed with a fibre containing a fibre grating with peak reflectivity of 3%, the output power from the fibre may exceed 90 Mw which is similar to that from a fibre with no grating, within experimental uncertainty.

Fig. 3 illustrates the optical output spectrum of the present invention. As can be seen, curve B is the output spectrum of a 980 nm InGaAs pigtailed diode laser without a fibre grating. There is approximately 0.5% feedback into the diode laser from a broadband external reflector, which causes destabilization of the laser wavelength. In curve A, the diode laser operates under the same conditions, but there is a fibre grating with a peak reflectivity of 3% and a bandwidth of 0.3 nm. The improvement of the output spectrum is clear. The output of the invention is stable even when the injection current or temperature of the laser diode are significantly altered. Accordingly, no control of the laser diode temperature is required in some instances, which eliminates the need for a laser cooler and the associated control electronics. The power requirement to control the laser temperature is also suitably reduced.

It should now be evident that the present invention provides a highly stabilized source of high-power optical radiation that will improve the characteristics and stability of optical amplifiers and lasers that must be pumped with such a source.

- 13 -

Although the preferred embodiment has been described in relation to its use with a fibre amplifier, it will be appreciated by those skilled in the art that it could also be used in association with a fibre laser and that
5 other modifications or variations may be made to the invention without departing from the scope thereof.

What is Claimed is:

1. A stabilized laser source for a fibre amplifier comprising:

5 a laser source having an optical cavity and providing an output at a facet, said laser source operating in multiple longitudinal modes;

an optical fibre optically coupled at one end to the optical cavity;

10 said optical fibre coupled at its other end to the fibre amplifier;

a fibre grating in said fibre to provide feedback to said laser source;

15 changes in longitudinal modal operation of said laser source in the absence of said grating creating noise in the operation of the fibre amplifier;

characterized in that

20 the fibre grating is positioned in the fibre a distance sufficiently far from the laser source facet to provide only incoherent feedback to the laser source causing coherence collapse operation in the laser source to suppress the occurrence of noise due to said longitudinal modal operation changes in the absence of said grating.

25 2. The stabilizer laser source of claim 1 wherein said fibre amplifier is an erbium doped fibre.

3. The stabilized laser source of claim 1 wherein said fibre grating has a bandwidth between 0.5 nm and about 1 nm.

30

4. The stabilized laser source of claim 1 wherein said grating distance in said fibre is preferably equal to or greater than the coherence length of the laser source.

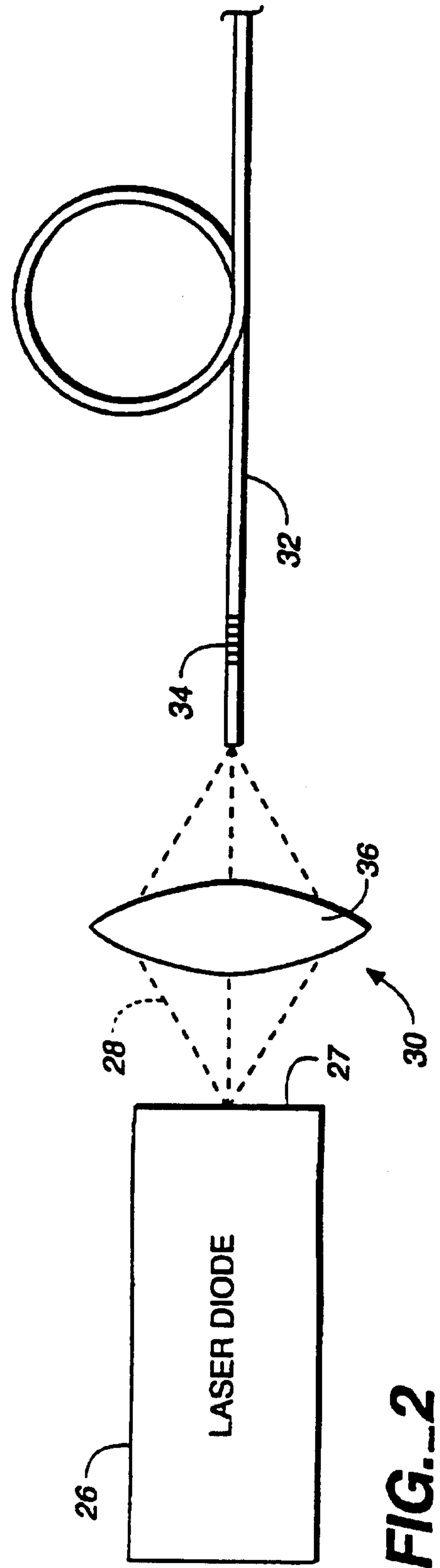
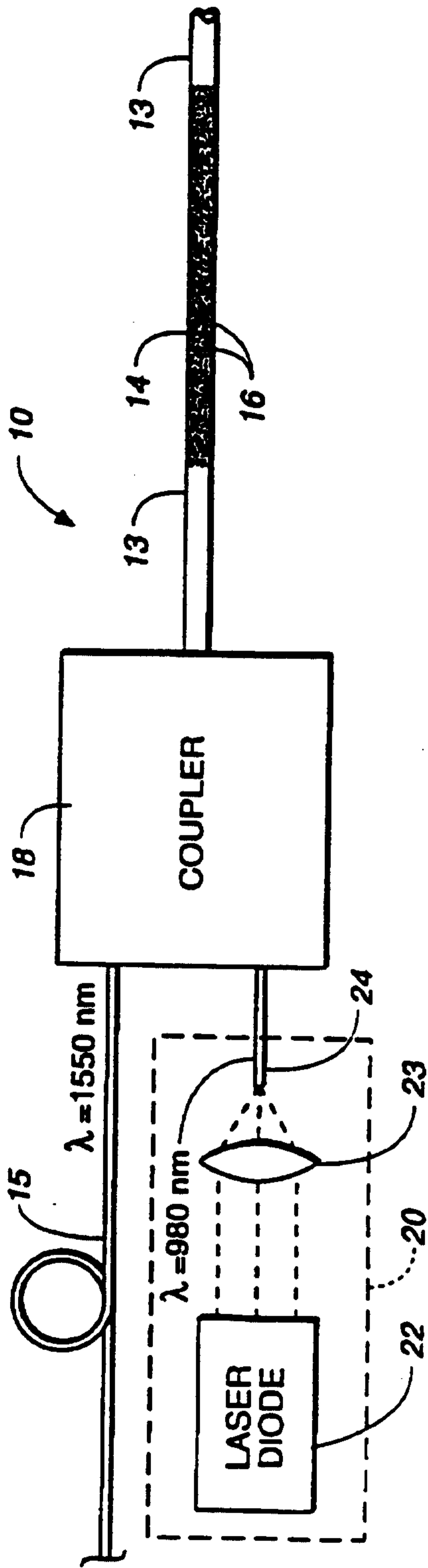

2/2

Fig. 3.

