



- (51) International Patent Classification:
A61F 2/14 (2006.01)
- (21) International Application Number:
PCT/US2017/021908
- (22) International Filing Date:
10 March 2017 (10.03.2017)
- (25) Filing Language: English
- (26) Publication Language: English
- (30) Priority Data:
62/307,304 11 March 2016 (11.03.2016) US
- (71) Applicant: THE REGENTS OF THE UNIVERSITY OF CALIFORNIA [US/US]; 1111 Franklin Street, 12th Floor, Oakland, California 94607-5200 (US).
- (72) Inventors: YEE, Albert; 51 Sweet Bay, Irvine, California 92603 (US). FARID, Marjan; University of California, Irvine, 850 Health Sciences Road, Irvine, California 92697 (US). STEINERT, Roger; University of California, 118 Med Surge I, Bldg. 810, Irvine, California 92697 (US). LI-ANG, Elena; 7402 Palo Verde Road, Irvine, CA 92617 (CA). DICKSON, Mary, Nora; 2506 Back Bay Loop, Costa Mesa, California 92627 (US).
- (74) Agent: SENN, Sean; Archer Norris, PLC, 777 S. Figueroa Street, Ste. 4250, Los Angeles, California 90017 (US).

(81) Designated States (unless otherwise indicated, for every kind of national protection available): AE, AG, AL, AM, AO, AT, AU, AZ, BA, BB, BG, BH, BN, BR, BW, BY, BZ, CA, CH, CL, CN, CO, CR, CU, CZ, DE, DJ, DK, DM, DO, DZ, EC, EE, EG, ES, FI, GB, GD, GE, GH, GM, GT, HN, HR, HU, ID, IL, IN, IR, IS, JP, KE, KG, KH, KN, KP, KR, KW, KZ, LA, LC, LK, LR, LS, LU, LY, MA, MD, ME, MG, MK, MN, MW, MX, MY, MZ, NA, NG, NI, NO, NZ, OM, PA, PE, PG, PH, PL, PT, QA, RO, RS, RU, RW, SA, SC, SD, SE, SG, SK, SL, SM, ST, SV, SY, TH, TJ, TM, TN, TR, TT, TZ, UA, UG, US, UZ, VC, VN, ZA, ZM, ZW.

(84) Designated States (unless otherwise indicated, for every kind of regional protection available): ARIPO (BW, GH, GM, KE, LR, LS, MW, MZ, NA, RW, SD, SL, ST, SZ, TZ, UG, ZM, ZW), Eurasian (AM, AZ, BY, KG, KZ, RU, TJ, TM), European (AL, AT, BE, BG, CH, CY, CZ, DE, DK, EE, ES, FI, FR, GB, GR, HR, HU, IE, IS, IT, LT, LU, LV, MC, MK, MT, NL, NO, PL, PT, RO, RS, SE, SI, SK, SM, TR), OAPI (BF, BJ, CF, CG, CI, CM, GA, GN, GQ, GW, KM, ML, MR, NE, SN, TD, TG).

Declarations under Rule 4.17:

- as to applicant's entitlement to apply for and be granted a patent (Rule 4.17(ii))
- as to the applicant's entitlement to claim the priority of the earlier application (Rule 4.17(iii))

[Continued on next page]

(54) Title: SYNTHETIC POLYMERIC IMPLANTABLE ARTIFICIAL CORNEA DEVICE INCORPORATING NANOPATTERNS

Figure 1

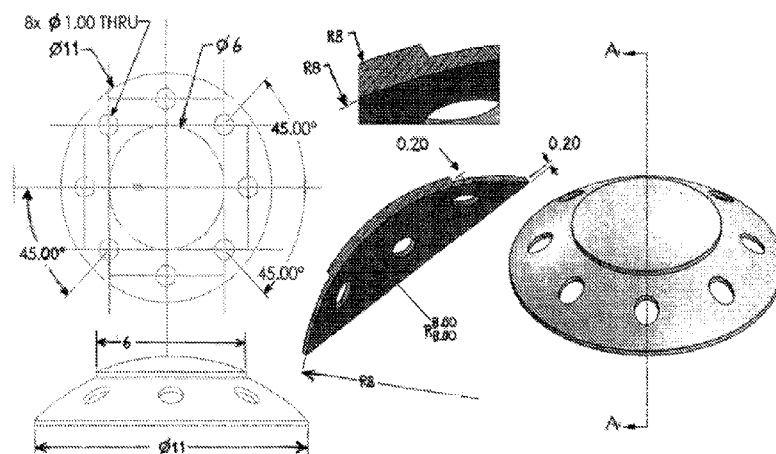

(57) Abstract: In one embodiment, the present invention is related to an artificial cornea comprising an optic zone that is similar in thickness to a natural cornea and a peripheral skirt having a thickness less than the thickness of the optic zone; and wherein the surfaces of the optic zone and peripheral skirt comprise one or more microstructures or nanostructures. In one embodiment, the present invention is also related to a method of implanting an artificial cornea comprising: (a) providing the artificial cornea comprising an optic zone that is similar in thickness to a natural cornea and a peripheral skirt having a thickness less than the thickness of the optic zone; wherein the surface of the artificial cornea comprises one or more microstructures or nanostructures; (b) the micrometer or nanometer wide lines in the peripheral skirt promotes host cell adhesion and integration; and (c) the micropillars or nanopillars deter host cell adhesion and provides antimicrobial properties to the artificial cornea.

Published:

— with international search report (Art. 21(3))

— before the expiration of the time limit for amending the claims and to be republished in the event of receipt of amendments (Rule 48.2(h))

SYNTHETIC POLYMERIC IMPLANTABLE ARTIFICIAL CORNEA DEVICE INCORPORATING NANOPATTERNS

FIELD OF THE INVENTION

5 The present disclosure is in the medical and biomedical field, specifically implantable medical devices.

BACKGROUND OF THE DISCLOSURE

10 Corneal blindness accounts for up to 50% of blindness. An artificial cornea is required in cases where a donor cornea is unavailable or is contraindicated. Currently available artificial cornea devices on the market, such as the Boston Keratoprosthesis for example, consists of poly(methyl methacrylate) front and back plates, sandwiching a donor cornea. In cases where a donor cornea is unavailable, there is no good substitute. Currently available artificial corneas are made of two materials, a clear optic zone, and a spongy, porous, or gel-
15 like skirt. The junction between the two materials is mechanically weak and is prone to failure. Additionally, this mismatch creates a site for inflammation or for bacterial infection. Indeed in the Boston Keratoprosthesis, stromal melt is often observed at the interface between the polymer portion and the donor cornea. As such, patients with artificial corneal prosthetics often require administration of antibiotics for the lifetime of the device.

20 Therefore there exists a need for a new artificial cornea that is easy to implant, durable, and has a decreased risk of microbial infections.

SUMMARY OF THE DISCLOSURE

25 In various embodiments, disclosed herein is an artificial cornea, comprising: an optic zone, having a thickness between 50 μm and 2 mm; and a peripheral skirt, having a thickness less than the thickness of the optic zone; and wherein the surfaces of the optic zone and peripheral skirt comprise one or more microstructures or nanostructures. In one embodiment, the peripheral skirt is tapered and is sutured into a host corneal tissue. In one embodiment, the artificial cornea has one continuous curvature on the posterior side. In one embodiment, the
30 artificial cornea is manufactured from a biocompatible material. In one embodiment, the artificial cornea is manufactured from a transparent plastic material. In one embodiment, the transparent plastic material is poly(methyl methacrylate). In one embodiment, the artificial

cornea further comprises a coating of metal oxides, fibronectin, laminin, collagen, and/or silane. In one embodiment, the optic zone and the peripheral skirt has the same radius of curvature. In one embodiment, the optic zone and the peripheral skirt has different radius of curvature. In one embodiment, the artificial cornea has a diameter between 8 mm and 11 mm.

5 In one embodiment, the optic zone has a diameter between 3 mm and 6 mm. In one embodiment, the peripheral skirt comprises one or more suture openings. In one embodiment, the number of suture openings is between 4 and 16. In one embodiment, the suture openings have a diameter between 0.5 mm and 2 mm. In one embodiment, the microstructures or nanostructures on the peripheral skirt comprise micrometer wide lines or nanometer wide
10 lines. In one embodiment, the micrometer wide lines or nanometer wide lines in the peripheral skirt promotes host cell adhesion. In one embodiment, the nanometer wide lines are between 200 nm and 2000 nm in width. In one embodiment, the microstructures or nanostructures are on the exterior surface of the peripheral skirt. In one embodiment, the microstructures or nanostructures are on the exterior and anterior surfaces of the peripheral
15 skirt. In one embodiment, the micrometer wide lines or nanometer wide lines may orient in any direction on the exterior and anterior surfaces of the prosthesis. In one embodiment, the microstructures or nanostructures on the optic zone comprise micropillars or nanopillars. In one embodiment, the nanopillars are between 20 to 200 nm in diameter. In one embodiment, the nanopillars are tapered at the tip and have a diameter between 10 nm and 200 nm. In one
20 embodiment, the micropillars or nanopillars have a round, curved, or rectilinear in cross-sectional shape. In one embodiment, the microstructures or nanostructures are on the exterior surface of the optic zone. In one embodiment, the microstructures or nanostructures are on the exterior and anterior surfaces of the optic zone. In one embodiment, the microstructures or nanostructures on the optic zone prevents formation of retroprosthetic membrane and
25 infectious keratitis. In one embodiment, the microstructures or nanostructures on the optic zone deters host cell adhesion. In one embodiment, the microstructures or nanostructures on the optic zone has antimicrobial or microbicidal properties. In one embodiment, the microstructures or nanostructures are fabricated from the same polymer as the artificial cornea device.

30 In various embodiments, disclosed herein is a method of manufacturing nanostructures on an artificial cornea comprising: providing an artificial cornea comprising an optic zone and a peripheral skirt; providing a planar master mold with nano features; fabricating an elastomeric replicate mold of the master mold; deforming the elastomeric negative mold into the desired curved architecture; and manufacturing nanostructures on the

artificial cornea by using the curved elastomeric negative mold to mold nanostructures on the artificial cornea. In one embodiment, the nanostructures on the peripheral skirt comprise nanometer wide lines. In one embodiment, the nanometer wide lines in the peripheral skirt promotes host cell adhesion. In one embodiment, the nanostructures on the optic zone
5 comprise nanopillars. In one embodiment, the nanostructures on the optic zone prevents formation of retroprosthetic membrane and/or infectious keratitis. In one embodiment, the nanostructures on the optic zone deters host cell adhesion. In one embodiment, the nanostructures on the optic zone has antimicrobial or microbicidal properties.

In various embodiments, disclosed herein is a method of treating a disease
10 comprising: providing an artificial cornea having microstructures or nanostructures; and treating a disease with the artificial cornea. In one embodiment, the artificial cornea comprises: an optic zone, having a thickness between 50 um and 2 mm; and a peripheral skirt, having a thickness less than the thickness of the optic zone; wherein the surface of the optic zone comprises nanometer wide lines that promotes host cell adhesion; and wherein the
15 surface of the peripheral skirt comprise nanopillars that deter host cell adhesion and provides antimicrobial properties to the artificial cornea. In one embodiment, the disease is a corneal disease.

Other features and advantages of the invention will become apparent from the following detailed description, taken in conjunction with the accompanying drawings, which
20 illustrate, by way of example, various embodiments of the invention.

DESCRIPTION OF THE DRAWINGS

Exemplary embodiments are illustrated in referenced figures. It is intended that the embodiments and figures disclosed herein are to be considered illustrative rather than
25 restrictive.

FIG. 1 illustrates, in accordance with embodiments herein, an artificial cornea made from poly-methylmethacrylate (PMMA), with nanostructures.

FIG. 2 illustrates, in accordance with embodiments herein, a process of making a curved nanostructured polymer surface.

DETAILED DESCRIPTION

All references, publications, and patents cited herein are incorporated by reference in their entirety as though they are fully set forth. Unless defined otherwise, technical and scientific terms used herein have the same meaning as commonly understood by one of
30

ordinary skill in the art to which this invention belongs. Hornyak, et al., Introduction to Nanoscience and Nanotechnology, CRC Press (2008); Singleton et al., Dictionary of Microbiology and Molecular Biology 3rd ed., J. Wiley & Sons (New York, NY 2001); March, Advanced Organic Chemistry Reactions, Mechanisms and Structure 7th ed., J. Wiley & Sons (New York, NY 2013); and Sambrook and Russel, Molecular Cloning: A Laboratory Manual 4th ed., Cold Spring Harbor Laboratory Press (Cold Spring Harbor, NY 2012), provide one skilled in the art with a general guide to many of the terms used in the present application. One skilled in the art will recognize many methods and materials similar or equivalent to those described herein, which could be used in the practice of the present invention. Indeed, the present invention is in no way limited to the methods and materials described.

The term “nanostructure(s),” as used herein, refers to structures having a size between molecular and microscopic structures. Typically, such structures have at least one dimension on the nanoscale, e.g., between about 1 nm and about 999 nm. The nanostructures can be configured so as to also include one or more of the following: (1) a nano surface having one dimension on the nanoscale, for example, a surface thickness between 1 nm and 999 nm; (2) a nanopillar or nanotube having two dimensions on the nanoscale, for example, a diameter and length each between 1 nm and 999 nm; and/or (3) a nanoparticle having three dimensions on the nanoscale, for example, the three spatial dimensions of the nanoparticle being between 1 nm and 999 nm. In one embodiment, the term nanopillar further refers to vertically oriented elongate structures, which may be straight, winding, zigzag, or crooked.

The term “microstructure(s),” as used herein, refers to structures having at least one dimension on the microscale, e.g., between about 1 μm and about 999 μm . The microstructures can be configured so as to include one or more of the following: (1) a micro surface having one dimension on the microscale, for example, a surface thickness between 1 μm and 999 μm ; (2) a micropillar or microtube having two dimensions on the microscale, for example, a diameter and length each between 1 μm and 999 μm ; and/or (3) a microparticle having three dimensions on the microscale, for example, the three spatial dimensions of the nanoparticle being between 1 μm and 999 μm . In one embodiment, the term micropillar further refers to vertically oriented elongate structures, which may be straight, winding, zigzag, or crooked.

The term “nanometer wide lines,” as used herein, refers to nanostructures in the shape of a line wherein the diameter of the line is between 1 nm and 999 nm. The term “micrometer wide lines,” as used herein, refers to microstructures in the shape of a line wherein the

diameter of the line is between 1 μm and 999 μm . The lines may be straight, winding, zigzag, or crooked.

The term “touch device,” as used herein, refers to a device that can be touched, or a device that is responsive to a touch. Examples of touch devices that are responsive to a touch
5 include, but not limited to, a keypad, touch screen, and/or one or more buttons to allow a user to enter some form of input.

As known to a skilled artisan in the art, the term “optic zone” refers to the center part of the artificial cornea, which functions as the optical part of the artificial cornea covering all or part of the anterior chamber of the eye.

10 As known to a skilled artisan in the art, the term “peripheral skirt” refers to the part of the artificial cornea that is located around and substantially surrounding perimeter of the optic zone. In one embodiment, the peripheral skirt traverses the anterior sclera beneath the conjunctiva-tenon complex.

As described herein, and in accordance with the various embodiments, the inventors
15 have created an implantable artificial cornea, wherein the surfaces of the artificial cornea comprise one or more microstructures or nanostructures, and wherein the microstructures or nanostructures are capable of possessing antimicrobial or microbicidal properties. In accordance with the various embodiments, described herein is a completely synthetic, implantable artificial cornea device with nanopatterns to control surface functions.

20 In accordance with various embodiments, disclosed herein is an artificial cornea comprising (a) an optic zone that is similar in thickness to a natural cornea; and (b) a peripheral skirt having a thickness less than the thickness of the optic zone; and wherein the surfaces of the optic zone and peripheral skirt comprise one or more microstructures or nanostructures. The term “similar” in thickness, as used herein, refers to a thickness that is
25 within 50% of each other, or more preferably within 25% of each other, or most preferably within 10% of each other. Thus the term optic zone that is similar in thickness to a natural cornea would refer to an optic zone whose thickness is +/-50% of the thickness of natural cornea, or more preferably +/-25% of the thickness of natural cornea, or most preferably +/-10% of the thickness of natural cornea. In one embodiment, the thickness of the optic zone is
30 50 μm – 2 mm, or more preferably 75 μm – 1.5 mm, or more preferably 100 μm – 1000 μm , or more preferably 200 μm – 800 μm , or more preferably 300 μm – 700 μm , or most preferably 400 μm – 600 μm . One embodiment of the artificial cornea is described in FIG. 1 herein. In some embodiments, the peripheral skirt is tapered such that it is capable of being sutured into a pocket in the host corneal tissue. In some embodiments, the peripheral skirt has

suture openings. In some embodiments, the artificial cornea is made in one piece. In some
embodiments, the artificial cornea has one continuous curvature on the posterior side. In
some embodiments, the optic zone protrudes into the eye in the posterior direction. In some
embodiments, the artificial cornea is manufactured from a transparent plastic material. In
5 some embodiments, the transparent plastic material is poly (methyl methacrylate). In some
embodiments, the transparent plastic material is an FDA approved material. In some
embodiments, the artificial cornea is manufactured from a biocompatible material. In some
embodiments, the optic zone and the peripheral skirt has the same radius of curvature. In
some embodiments, the optic zone and the peripheral skirt has different radius of curvature.
10 In some embodiments, the cornea device has a diameter between 8 mm and 11 mm. In some
embodiments, the optic zone has a diameter between 3 mm and 6 mm. In some embodiments,
the peripheral skirt comprises suture openings. In some embodiments, the number of suture
openings is between 4 and 16. In some embodiments, each of the suture openings has a
diameter between 0.5 mm and 2 mm.

15 In various embodiments, the microstructures or nanostructures on the peripheral skirt
of the artificial cornea comprise micrometer wide lines or nanometer wide lines. In one
embodiment, the micrometer wide lines or nanometer wide lines in the peripheral skirt
promotes host cell adhesion. In some embodiments, the nanometer wide lines are between
200 nm and 2000 nm in width. In some embodiments, the peripheral skirt comprises a
20 coating comprising metal oxides, fibronectin, laminin, collagen or silane. In some
embodiments, the microstructures or nanostructures are on the exterior surface of the
peripheral skirt. In some embodiments, the microstructures or nanostructures are on the
exterior and anterior surfaces of the peripheral skirt. In some embodiments, the micrometer
wide lines or nanometer wide lines may orient in any direction on the exterior and anterior
25 surfaces of the prosthesis.

In various embodiments, the microstructures or nanostructures on the optic zone of
the artificial cornea comprise micropillars or nanopillars. In some embodiments, the
microstructures or nanostructures are on the exterior surface of the optic zone. In some
embodiments, the microstructures or nanostructures are on the exterior and anterior surfaces
30 of the optic zone. In one embodiment, the microstructures or nanostructures on the optic zone
prevents formation of retroprosthetic membrane and infectious keratitis. In some
embodiments, the microstructures or nanostructures on the optic zone deters host cell
adhesion. In some embodiments, the microstructures or nanostructures on the optic zone has
antimicrobial or microbicidal properties. In some embodiments, the optic zone comprises a

coating, comprising metal oxides, fibronectin, laminin, collagen or silane. In some embodiments, the nanopillars are between 20 nm to 200 nm in diameter. In some embodiments, the nano-pillars are tapered at the tip and has a diameter between 10 nm and 200 nm. In some embodiments, the micropillars or nanopillars have a round, curved, or
5 rectilinear in cross-sectional shape. In some embodiments, the microstructures or nanostructures are fabricated from the same polymer as the artificial cornea device.

In one embodiment, the micrometer wide lines or nanometer wide lines are not on the optic zone of the artificial cornea.

In various embodiments, disclosed herein is a method of making an artificial cornea
10 comprising: (a) providing a planar master mold with micro or nano features; (b) fabricating an elastomeric replicate mold (elastomeric negative mold) of the master mold; (c) deforming the elastomeric negative mold into the desired curved architecture; and (d) using the curved elastomeric negative mold to mold a microstructure or nanostructure structure on the artificial cornea.

In various embodiments, disclosed herein is a method of implanting an artificial
15 cornea comprising: (a) providing the artificial cornea comprising an optic zone that is similar in thickness to a natural cornea and a peripheral skirt having a thickness less than the thickness of the optic zone; wherein the surface of the artificial cornea comprises one or more microstructures or nanostructures; (b) the nanometer wide lines in the peripheral skirt
20 promotes host cell adhesion and integration; and (c) the nanopillars deter host cell adhesion and provides antimicrobial properties to the artificial cornea.

In various embodiments, disclosed herein is a kit comprising: (a) an artificial cornea;
25 (b) composition for making microstructures and nanostructures as described herein; and (c) wherein the microstructures or nanostructures provide antimicrobial or microbicidal properties.

In various embodiments, disclosed herein is a method of treating a disease
comprising: (a) an artificial cornea having microstructures or nanostructures; and (b) treating a disease with the artificial cornea.

In various embodiments, disclosed herein is a treatment regimen comprising: (a) an
30 artificial cornea having microstructures or nanostructures; and (b) a treatment regimen that using the artificial cornea.

Throughout the disclosure, nanopillars possess a diameter and length each between 1 nm and 999 nm, and they are spaced between 1 nm and 999 nm of each other. Similarly,

micropillars possess a diameter and length each between 1 μm and 999 μm , and they are spaced between 1 μm and 999 μm of each other.

In one embodiment, the corneal prosthesis described in the present disclosure would not have the drawbacks in the Boston Keratoprosthesis device, including stromal melt at the interface between materials. In one embodiment, the artificial cornea described herein is easy to implant and durable in use because the device is made from a hard polymer. In one embodiment, the micro- or nano- features on the device enables the device to have a decreased risk of bacterial infection. Additionally, in some embodiments, the use of the same polymer for both the optic zone and the skirt prevents the possibility of adhesive failure as would occur when different materials are assembled by adhesives.

Use of nano-scopic features on the surfaces of the device to direct cell response is a novel and advantageous strategy. Currently available technology in the field use either (a) a chemical coating, or tethered biomolecules, or (b) a porous or spongy microarchitecture to encourage adhesion. A chemical's coating efficacy can be diminished by various factors, such as: chemical decomposition masking of surface chemical moieties by ions and proteins naturally present in the eye; and local variations in chemical concentrations. Correct inclusions of porous microarchitectures could aid in host-cell integration; however, they are difficult to manufacture consistently. Moreover, these spongy materials are mechanically fragile, given the limited thickness of the prostheses. Importantly, there are regions of the cornea device that should be protected from overgrowth of host cells, which would reduce the transparency. No microarchitecture can perform this role and possess transparency. Moreover the features that deter host cell adhesion have also been found to be antibacterial, which is also advantageous compared to Boston K-pro Keratoprosthesis.

The present disclosure is also directed to a kit for adding a micro-structure or nano-structure coating in artificial corneas. The kit is useful for practicing the inventive method of providing the device with antimicrobial and/or microbicidal properties. The kit is an assemblage of materials or components, including at least one of the inventive compositions. Thus, in some embodiments the kit contains a composition comprising one or more elastomeric molds, polymer solution, and holders, as described above.

The exact nature of the components configured in the inventive kit depends on its intended purpose. For example, some embodiments are configured for the purpose of providing microbicidal and antimicrobial properties in an artificial cornea. In another embodiment, the kit is configured for the purposes of treating mammalian subjects. In another embodiment, the kit is configured particularly for the purpose of treating human

subjects. In further embodiments, the kit is configured for veterinary applications, treating subjects such as, but not limited to, farm animals, domestic animals, and laboratory animals.

Instructions for use may be included in the kit. "Instructions for use" typically include a tangible expression describing the technique to be employed in using the components of the kit to effect a desired outcome, such as to provide microstructures or nanostructures on artificial corneas. Optionally, the kit also contains other useful components, such as, diluents, buffers, pharmaceutically acceptable carriers, syringes, catheters, applicators, pipetting or measuring tools, bandaging materials or other useful paraphernalia as will be readily recognized by those of skill in the art.

The materials or components assembled in the kit can be provided to the practitioner stored in any convenient and suitable ways that preserve their operability and utility. For example the components can be in dissolved, dehydrated, or lyophilized form; they can be provided at room, refrigerated or frozen temperatures. The components are typically contained in suitable packaging material(s). As employed herein, the phrase "packaging material" refers to one or more physical structures used to house the contents of the kit, such as inventive compositions and the like. The packaging material is constructed by well-known methods, preferably to provide a sterile, contaminant-free environment. The packaging materials employed in the kit are those customarily utilized in the medical device industry and/or in the polymer industry. As used herein, the term "package" refers to a suitable solid matrix or material such as glass, plastic, paper, foil, and the like, capable of holding the individual kit components. Thus, for example, a package can be a glass vial used to contain suitable quantities of the presently disclosed inventive composition. The packaging material generally has an external label which indicates the contents and/or purpose of the kit and/or its components.

Embodiments of the present disclosure are further described in the following examples. The examples are merely illustrative and do not in any way limit the scope of the invention as claimed.

EXAMPLES

EXAMPLE 1

PMMA artificial cornea

FIG. 1 illustrates one embodiment of the artificial cornea as described herein. The artificial cornea was made of a transparent plastic material, poly(methyl methacrylate)

(PMMA). As recognized by a skilled artisan in the art, other materials could also be used, including those that are already FDA approved and known to be biocompatible. In this embodiment, the cornea has one continuous curvature on the posterior side. In one embodiment, the central part (“the optic zone”), and the peripheral part (“the peripheral skirt”) may have different radii of curvature.

The polymer cornea device of FIG. 1 comprises precisely defined nano-scopic features on the surfaces of the device that can direct cell response. Specifically, the exterior and anterior surfaces of the skirt has nanometer-wide lines that promote host cell adhesion and integration, and the exterior and anterior surfaces of the optic zone has nanometer diameter pillars that deter cell adhesion, and to prevent formation of retroprosthetic membrane and infectious keratitis. Moreover, the inventors found that the above features that deter host cell adhesion is also antibacterial, which is advantageous.

EXAMPLE 2

Method of making a curved patterned surface

FIG. 2 illustrates one embodiment of making a curved patterned surface, such as an artificial cornea as described herein. Referring to FIG. 2, in step 1, a hard mold (*i*) with nanopillars with 300 nm periodicity was provided. The pillars were 190 nm in diameter and 300 nm in height. High modulus polydimethyl siloxane (hPDMS) was pipetted onto (*i*) and left at room temperature for 1.5 hours then cured at 65 °C for 0.5 hour. After the hPDMS was cured, polydimethyl siloxane (PDMS) prepolymer was poured on top and cured at 80 °C for one hour. After PDMS was cured, the planar silicone mold (*ii*) was demolded. As would be readily known to a skilled artisan, the periodicity, height, and diameter of the nanopillars can be changed by changing the mold.

In step 2 of FIG. 2, PDMS was poured in glass container (*iii*) and cured at 80 °C for one hour. The PDMS sheet (*iv*) was then peeled off from the glass container (*iii*). In step 3, the silicone mold (*ii*) and the PDMS sheet (*iv*) were coated with perfluorodecyltrichlorosilane (FDTS) using Molecular Vapor Deposition (MVD) to form (*v*) and (*vi*). The MVD process formed a uniform thin film of FDTS on the substrate by depositing molecules at low temperature. The FDTS monolayer reduces surface energy. FDTS is an anti-sticking precursor used to prevent adhesion between coated items with another material.

In step 4 of FIG. 2, PDMS solution was pipetted into a smaller glass container (*vii*). The FDTS coated PDMS sheet (*vi*) was pressed into the PDMS solution in the glass container

(vii) with a tool (viii), with the FDTS coated side contacting PDMS, to produce a concave surface. The tool used in this procedure had a diameter of 1.5 cm with a radius of curvature of 0.69 cm. It was then cured at 80 °C for one hour and afterwards demolded. (ix) was made to be the holder for transferring the pattern and also for controlling the surface contour. As
5 would be readily known to a skilled artisan, the thickness and radius of curvature can be easily changed, and the present disclosure is in no way limited to the specific radii and thickness disclosed herein.

In step 5 of FIG. 2, hPDMS was pipetted into (ix). (v) was pressed with the tool (viii) and left at room temperature for 1.5 hours for the hPDMS to fill the features, then cured at 65
10 °C for 0.5 hour. The pattern was transferred onto the concave surface after cooling and demolded. (x) was the non-planar silicone mold.

In step 6 of FIG. 2, poly-methylmethacrylate (PMMA) solution was pipetted into (x) and placed under vacuum to remove air bubbles. After the toluene had evaporated, the PMMA lens (xii) was peeled off from (xi). Using photo-polymerization to form a cross-linked
15 PMMA lens helped in controlling the durability and thickness of the device. Finally, in step 7, (viii) was used to press (v) onto (xi). The lens (xiii) had nano-patterns on both sides after the solvent had evaporated.

The various methods and techniques described above provide a number of ways to carry out the invention. Of course, it is to be understood that not necessarily all objectives or
20 advantages described may be achieved in accordance with any particular embodiment described herein. Thus, for example, those skilled in the art will recognize that the methods can be performed in a manner that achieves or optimizes one advantage or group of advantages as taught herein without necessarily achieving other objectives or advantages as may be taught or suggested herein. A variety of advantageous and disadvantageous
25 alternatives are mentioned herein. It is to be understood that some preferred embodiments specifically include one, another, or several advantageous features, while others specifically exclude one, another, or several disadvantageous features, while still others specifically mitigate a present disadvantageous feature by inclusion of one, another, or several advantageous features.

30 Furthermore, the skilled artisan will recognize the applicability of various features from different embodiments. Similarly, the various elements, features and steps discussed above, as well as other known equivalents for each such element, feature or step, can be mixed and matched by one of ordinary skill in this art to perform methods in accordance with

principles described herein. Among the various elements, features, and steps some will be specifically included and others specifically excluded in diverse embodiments.

Although the invention has been disclosed in the context of certain embodiments and examples, it will be understood by those skilled in the art that the embodiments of the invention extend beyond the specifically disclosed embodiments to other alternative
5 embodiments and/or uses and modifications and equivalents thereof.

Many variations and alternative elements have been disclosed in embodiments of the present invention. Still further variations and alternate elements will be apparent to one of skill in the art. Among these variations, without limitation, are the selection of constituent
10 modules for the inventive compositions, and the diseases and other clinical conditions that may be diagnosed, prognosed or treated therewith. Various embodiments of the invention can specifically include or exclude any of these variations or elements.

In some embodiments, the numbers expressing quantities of ingredients, properties such as concentration, reaction conditions, and so forth, used to describe and claim certain
15 embodiments of the invention are to be understood as being modified in some instances by the term “about.” Accordingly, in some embodiments, the numerical parameters set forth in the written description and attached claims are approximations that can vary depending upon the desired properties sought to be obtained by a particular embodiment. In some
20 embodiments, the numerical parameters should be construed in light of the number of reported significant digits and by applying ordinary rounding techniques. Notwithstanding that the numerical ranges and parameters setting forth the broad scope of some embodiments of the invention are approximations, the numerical values set forth in the specific examples are reported as precisely as practicable. The numerical values presented in some
25 embodiments of the invention may contain certain errors necessarily resulting from the standard deviation found in their respective testing measurements.

In some embodiments, the terms “a,” “an,” and “the” and similar references used in the context of describing a particular embodiment of the invention (especially in the context of certain of the following claims) can be construed to cover both the singular and the plural. The recitation of ranges of values herein is merely intended to serve as a shorthand method of
30 referring individually to each separate value falling within the range. Unless otherwise indicated herein, each individual value is incorporated into the specification as if it were individually recited herein. All methods described herein can be performed in any suitable order unless otherwise indicated herein or otherwise clearly contradicted by context. The use of any and all examples, or exemplary language (e.g. “such as”) provided with respect to

certain embodiments herein is intended merely to better illuminate the invention and does not pose a limitation on the scope of the invention otherwise claimed. No language in the specification should be construed as indicating any non-claimed element essential to the practice of the invention.

5 Groupings of alternative elements or embodiments of the invention disclosed herein are not to be construed as limitations. Each group member can be referred to and claimed individually or in any combination with other members of the group or other elements found herein. One or more members of a group can be included in, or deleted from, a group for reasons of convenience and/or patentability. When any such inclusion or deletion occurs, the
10 specification is herein deemed to contain the group as modified thus fulfilling the written description of all Markush groups used in the appended claims.

 Preferred embodiments of this invention are described herein, including the best mode known to the inventors for carrying out the invention. Variations on those preferred embodiments will become apparent to those of ordinary skill in the art upon reading the
15 foregoing description. It is contemplated that skilled artisans can employ such variations as appropriate, and the invention can be practiced otherwise than specifically described herein. Accordingly, many embodiments of this invention include all modifications and equivalents of the subject matter recited in the claims appended hereto as permitted by applicable law. Moreover, any combination of the above-described elements in all possible variations thereof
20 is encompassed by the invention unless otherwise indicated herein or otherwise clearly contradicted by context.

 Furthermore, numerous references have been made to patents and printed publications throughout this specification. Each of the above cited references and printed publications are herein individually incorporated by reference in their entirety.

25 In closing, it is to be understood that the embodiments of the invention disclosed herein are illustrative of the principles of the present invention. Other modifications that can be employed can be within the scope of the invention. Thus, by way of example, but not of limitation, alternative configurations of the present invention can be utilized in accordance with the teachings herein. Accordingly, embodiments of the present invention are not limited
30 to that precisely as shown and described.

CLAIMS

What is claimed is:

1. An artificial cornea, comprising:
 - an optic zone having a thickness between 50 μm and 2 mm; and
 - a peripheral skirt having a thickness less than the optic zone,
 - wherein the surfaces of the optic zone and peripheral skirt comprise one or more microstructures and/or nanostructures.
2. The artificial cornea of claim 1, wherein the peripheral skirt is tapered and is sutured into a host corneal tissue.
3. The artificial cornea of claim 1, wherein the artificial cornea has one continuous curvature on the posterior side.
4. The artificial cornea of claim 1, wherein the artificial cornea is manufactured from a biocompatible material.
5. The artificial cornea of claim 1, wherein the artificial cornea is manufactured from a transparent plastic material.
6. The artificial cornea of claim 5, wherein the transparent plastic material is poly(methyl methacrylate).
7. The artificial cornea of claim 5, wherein the artificial cornea further comprises a coating of metal oxides, fibronectin, laminin, collagen, and/or silane.
8. The artificial cornea of claim 1, wherein the optic zone and the peripheral skirt has the same radius of curvature.
9. The artificial cornea of claim 1, wherein the optic zone and the peripheral skirt has different radius of curvature.
10. The artificial cornea of claim 1, wherein the artificial cornea has a diameter between 8 mm and 11 mm.

11. The artificial cornea of claim 1, wherein the optic zone has a diameter between 3 mm and 6 mm.
12. The artificial cornea of claim 1, wherein the peripheral skirt comprises one or more suture openings.
13. The artificial cornea of claim 12, wherein the number of suture openings is between 4 and 16.
14. The artificial cornea of claim 12, wherein each the suture openings have a diameter between 0.5 mm and 2 mm.
15. The artificial cornea of claim 1, wherein the microstructures or nanostructures on the peripheral skirt comprise micrometer wide lines or nanometer wide lines.
16. The artificial cornea of claim 15, wherein the micrometer wide lines or nanometer wide lines in the peripheral skirt promotes host cell adhesion.
17. The artificial cornea of claim 15, wherein the nanometer wide lines are between 200 nm and 2000 nm in width.
18. The artificial cornea of claim 15, wherein the microstructures or nanostructures are on the exterior surface of the peripheral skirt.
19. The artificial cornea of claim 15, wherein the microstructures or nanostructures are on the exterior and anterior surfaces of the peripheral skirt.
20. The artificial cornea of claim 15, wherein the micrometer wide lines or nanometer wide lines may orient in any direction on the exterior and anterior surfaces of the prosthesis.
21. The artificial cornea of claim 1, wherein the microstructures or nanostructures on the optic zone comprise micropillars or nanopillars.

22. The artificial cornea of claim 21, wherein the nanopillars are between 20 to 200 nm in diameter.
23. The artificial cornea of claim 21, wherein the nanopillars are tapered at the tip and have a diameter between 10 nm and 200 nm.
24. The artificial cornea of claim 21, wherein the micropillars or nanopillars have a round, curved, or rectilinear in cross-sectional shape.
25. The artificial cornea of claim 21, wherein the microstructures or nanostructures are on the exterior surface of the optic zone.
26. The artificial cornea of claim 21, wherein the microstructures or nanostructures are on the exterior and anterior surfaces of the optic zone.
27. The artificial cornea of claim 21, wherein the microstructures or nanostructures on the optic zone prevents formation of retroprosthetic membrane and infectious keratitis.
28. The artificial cornea of claim 21, wherein the microstructures or nanostructures on the optic zone deters host cell adhesion.
29. The artificial cornea of claims 21, wherein the microstructures or nanostructures on the optic zone has antimicrobial or microbicidal properties.
30. The artificial cornea of claim 1, wherein the microstructures or nanostructures are fabricated from the same polymer as the artificial cornea device.
31. A method of manufacturing nanostructures on an artificial cornea comprising:
 - providing an artificial cornea comprising an optic zone and a peripheral skirt;
 - providing a planar master mold with a plurality of nano features;
 - fabricating an elastomeric replicate mold of the planar master mold;
 - deforming an elastomeric negative mold into a desired curved architecture; and

using the desired curved architecture to mold nanostructures on the artificial cornea.

32. The method of claim 31, wherein the nanostructures on the peripheral skirt comprise nanometer wide lines.
33. The method of claim 32, wherein the nanometer wide lines in the peripheral skirt promotes host cell adhesion.
34. The method of claim 31, wherein the nanostructures on the optic zone comprise nanopillars.
35. The method of claim 31, wherein the nanostructures on the optic zone prevents formation of retroprosthetic membrane and/or infectious keratitis.
36. The method of claim 31, wherein the nanostructures on the optic zone deters host cell adhesion.
37. The method of claim 31, wherein the nanostructures on the optic zone has antimicrobial or microbicidal properties.
38. A method of treating a disease in an individual comprising:
 - providing an artificial cornea comprising one or more microstructures and/or nanostructures; and
 - treating the disease in the individual with the artificial cornea.
39. The method of claim 38, wherein the artificial cornea comprises:
 - an optic zone, having a thickness between 50 um and 2 mm; and
 - a peripheral skirt, having a thickness less than the thickness of the optic zone; and
 - wherein the surface of the optic zone comprises nanometer wide lines that promotes host cell adhesion; and
 - wherein the surface of the peripheral skirt comprise nanopillars that deter host cell adhesion and provides antimicrobial properties to the artificial cornea.

40. The method of claim 38, wherein the disease is a corneal disease.

Figure 1.

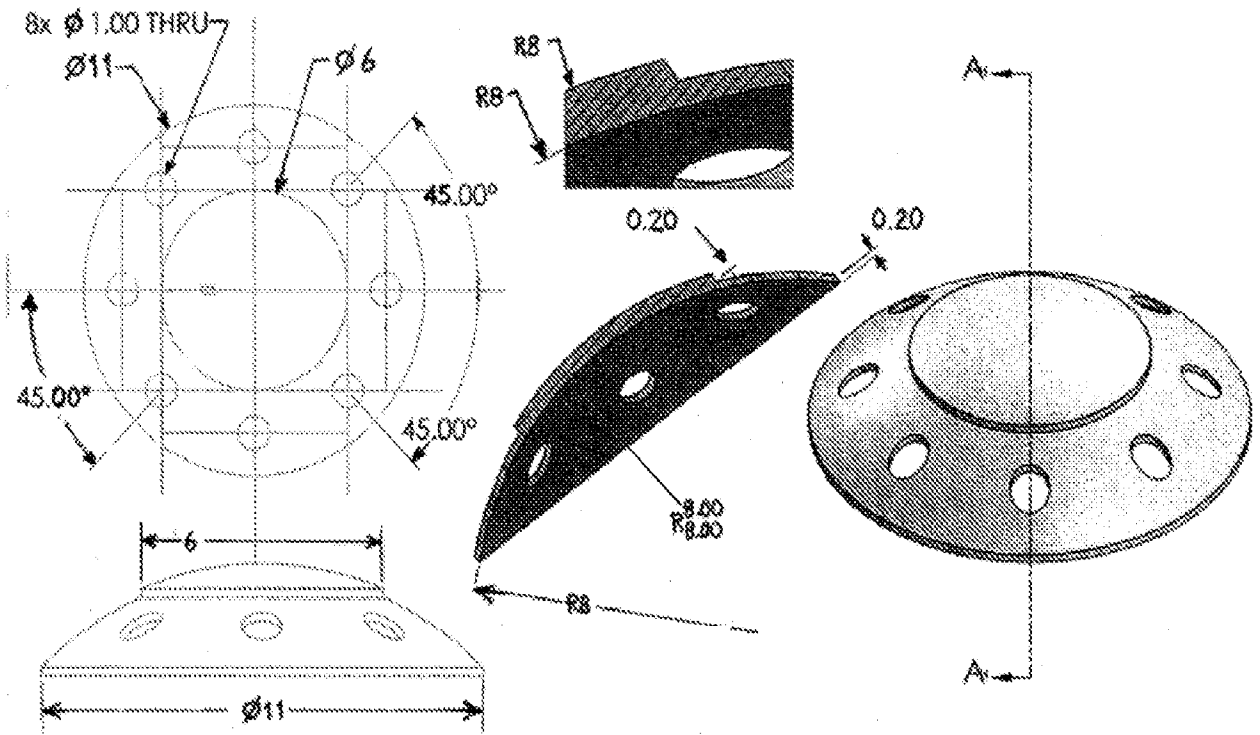
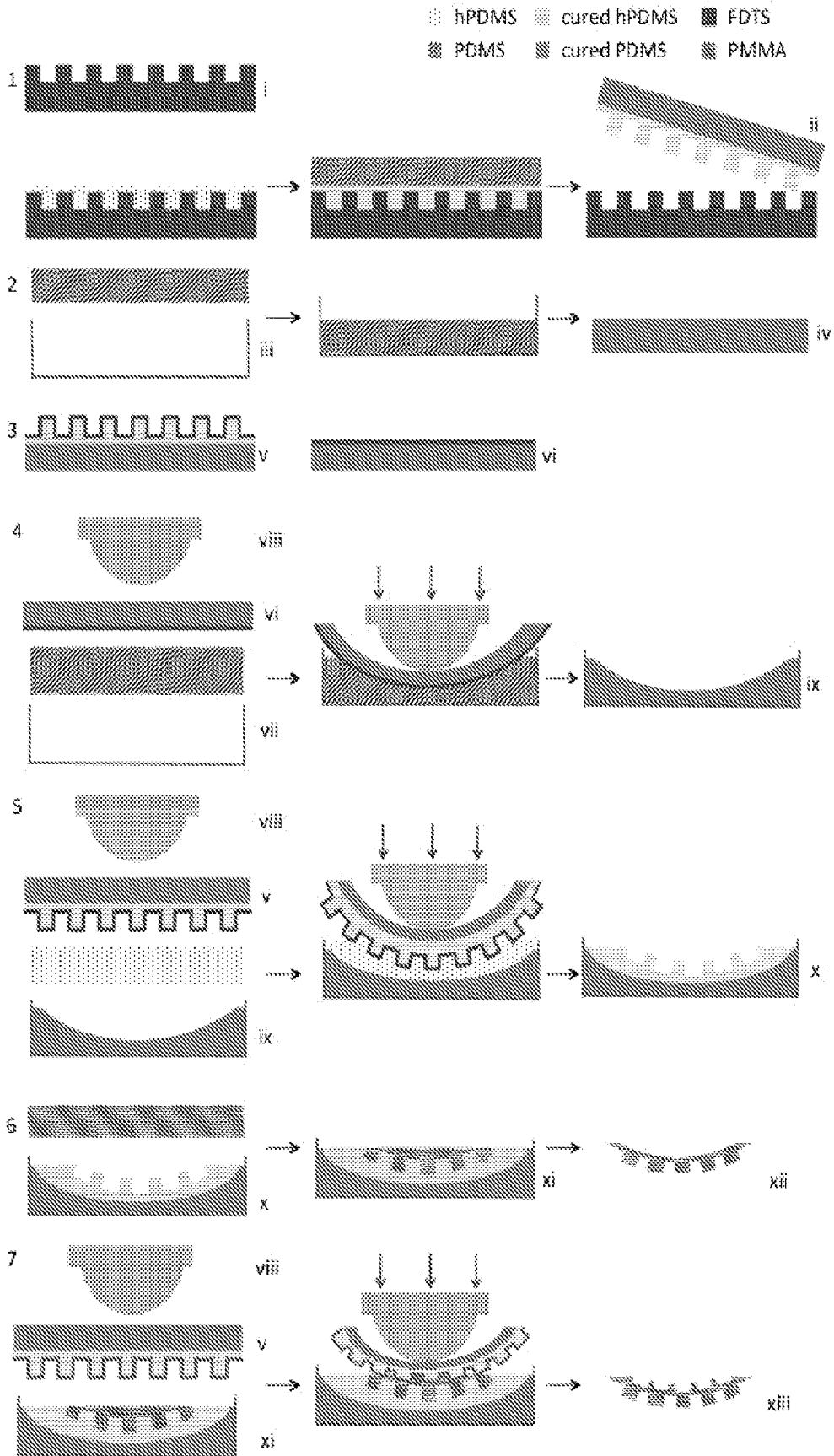

Figure 2.



INTERNATIONAL SEARCH REPORT

International application No.

PCT/US17/21908

A. CLASSIFICATION OF SUBJECT MATTER
 IPC - A61F2/14 (2017.01)
 CPC - A61F2/14, A61F2/142

According to International Patent Classification (IPC) or to both national classification and IPC

B. FIELDS SEARCHED

Minimum documentation searched (classification system followed by classification symbols)
 See Search History document

Documentation searched other than minimum documentation to the extent that such documents are included in the fields searched
 See Search History document

Electronic data base consulted during the international search (name of data base and, where practicable, search terms used)
 See Search History document

C. DOCUMENTS CONSIDERED TO BE RELEVANT

Category*	Citation of document, with indication, where appropriate, of the relevant passages	Relevant to claim No.
X -- Y	US 2011/0125260 A1 (SHEN, TT) May 26, 2011; abstract; figures 1A-B; paragraphs [0032], [0042], [0048], [0050]-[0053], [0066]-[0070]; claims 1, 5, 7-8, 13	1-8, 10, 11, 30 ----- 9, 12-29
Y	US 2007/0168025 A1 (DAROUGAR, S, et al.) July 19, 2007; figures 1-3; paragraphs [0017], [0050]	9, 12-14
Y	WO 2015/055656 A1 (UAB FERENTIS) April 23, 2015; page 16, first paragraph; figure 12	15-20
Y	US 2013/0244889 A1 (AGENCY FOR SCIENCE TECHNOLOGY AND RESEARCH) September 19, 2013; figures 12-13; paragraph [0047]; claims 1, 5, 7	21-29
Y	US 2011/0135814 A1 (MAYAUCHI, A, et al.) June 9, 2011; figure 4f; paragraph [0010]	23
Y	US 2011/0160851 A1 (MUELLER-LIERHEIM, W, et al.) June 30, 2011; paragraph [0017]-[0021]	27-28
A	US 6106552 A (LACOMBE, E, et al.) August 22, 2000; entire document	1-30

Further documents are listed in the continuation of Box C. See patent family annex.

* Special categories of cited documents:	"T" later document published after the international filing date or priority date and not in conflict with the application but cited to understand the principle or theory underlying the invention
"A" document defining the general state of the art which is not considered to be of particular relevance	"X" document of particular relevance; the claimed invention cannot be considered novel or cannot be considered to involve an inventive step when the document is taken alone
"E" earlier application or patent but published on or after the international filing date	"Y" document of particular relevance; the claimed invention cannot be considered to involve an inventive step when the document is combined with one or more other such documents, such combination being obvious to a person skilled in the art
"L" document which may throw doubts on priority claim(s) or which is cited to establish the publication date of another citation or other special reason (as specified)	"&" document member of the same patent family
"O" document referring to an oral disclosure, use, exhibition or other means	
"P" document published prior to the international filing date but later than the priority date claimed	

Date of the actual completion of the international search
 23 June 2017 (23.06.2017)

Date of mailing of the international search report
07 JUL 2017

Name and mailing address of the ISA/
 Mail Stop PCT, Attn: ISA/US, Commissioner for Patents
 P.O. Box 1450, Alexandria, Virginia 22313-1450
 Facsimile No. 571-273-8300

Authorized officer
 Shane Thomas
 PCT Helpdesk: 571-272-4300
 PCT OSP: 571-272-7774

INTERNATIONAL SEARCH REPORT

International application No.

PCT/US17/21908

Box No. II Observations where certain claims were found unsearchable (Continuation of item 2 of first sheet)

This international search report has not been established in respect of certain claims under Article 17(2)(a) for the following reasons:

1. Claims Nos.:
because they relate to subject matter not required to be searched by this Authority, namely:

2. Claims Nos.:
because they relate to parts of the international application that do not comply with the prescribed requirements to such an extent that no meaningful international search can be carried out, specifically:

3. Claims Nos.:
because they are dependent claims and are not drafted in accordance with the second and third sentences of Rule 6.4(a).

Box No. III Observations where unity of invention is lacking (Continuation of item 3 of first sheet)

This International Searching Authority found multiple inventions in this international application, as follows:

-Continued Within the Next Supplemental Box-

1. As all required additional search fees were timely paid by the applicant, this international search report covers all searchable claims.
2. As all searchable claims could be searched without effort justifying additional fees, this Authority did not invite payment of additional fees.
3. As only some of the required additional search fees were timely paid by the applicant, this international search report covers only those claims for which fees were paid, specifically claims Nos.:

4. No required additional search fees were timely paid by the applicant. Consequently, this international search report is restricted to the invention first mentioned in the claims; it is covered by claims Nos.:
1-30

- Remark on Protest**
- The additional search fees were accompanied by the applicant's protest and, where applicable, the payment of a protest fee.
 - The additional search fees were accompanied by the applicant's protest but the applicable protest fee was not paid within the time limit specified in the invitation.
 - No protest accompanied the payment of additional search fees.

INTERNATIONAL SEARCH REPORT
Information on patent family members

International application No.
PCT/US17/21908

.-***-Continued from Box No. III Observations where unity of invention is lacking-***-

This application contains the following inventions or groups of inventions which are not so linked as to form a single general inventive concept under PCT Rule 13.1. In order for all inventions to be examined, the appropriate additional examination fees must be paid.

Group I: Claims 1-30 are directed toward an artificial cornea, comprising: an optic zone having a thickness between 50 urn and 2 mm; and a peripheral skirt having a thickness less than the optic zone.

Group II: Claims 31-37 are directed toward a method comprising providing a planar master mold with a plurality of nano features; fabricating an elastomeric replicate mold, and deforming an elastomeric negative mold.

Group III: Claims 38-40 are directed toward a method of treating a disease in an individual comprising: treating the disease in the individual with the artificial cornea.

The inventions listed as Groups I-III do not relate to a single general inventive concept under PCT Rule 13.1 because, under PCT Rule 13.2, they lack the same or corresponding special technical features for the following reasons.

The special technical features of Group I include an optic zone having a thickness between 50 urn and 2 mm; and a peripheral skirt having a thickness less than the optic zone (which is not present in Groups II or III)

The special technical features of Group II include providing an artificial cornea comprising an optic zone and a peripheral skirt (which is not present in Group III); providing a planar master mold with a plurality of nano features; fabricating an elastomeric replicate mold of the planar master mold; deforming an elastomeric negative mold into a desired curved architecture; and using the desired curved architecture to mold nanostructures on the artificial cornea (which is not present in Groups I or III).

The special technical features of Group III include a method of treating a disease in an individual comprising treating the disease in the individual with the artificial cornea (which is not present in Groups II or III).

The common technical features of Groups I, II, and III include providing an artificial cornea comprising an optic zone and a peripheral skirt; and one or more microstructures and/or nanostructures.

These common technical features are disclosed by US 6,106,552 (LACOMBE): providing an artificial cornea (corneal prosthesis; abstract) comprising an optic zone (optical part 10; abstract) and a peripheral skirt (annular anterior skirt 18; abstract); and one or more microstructures and/or nanostructures (material is obtained by sintering microbeads of different diameters; column 2, lines 60-67).

Because the common technical features are disclosed by Lacombe, the inventions are not so linked as to form a single general inventive concept. Therefore, Groups I-III lack unity.