

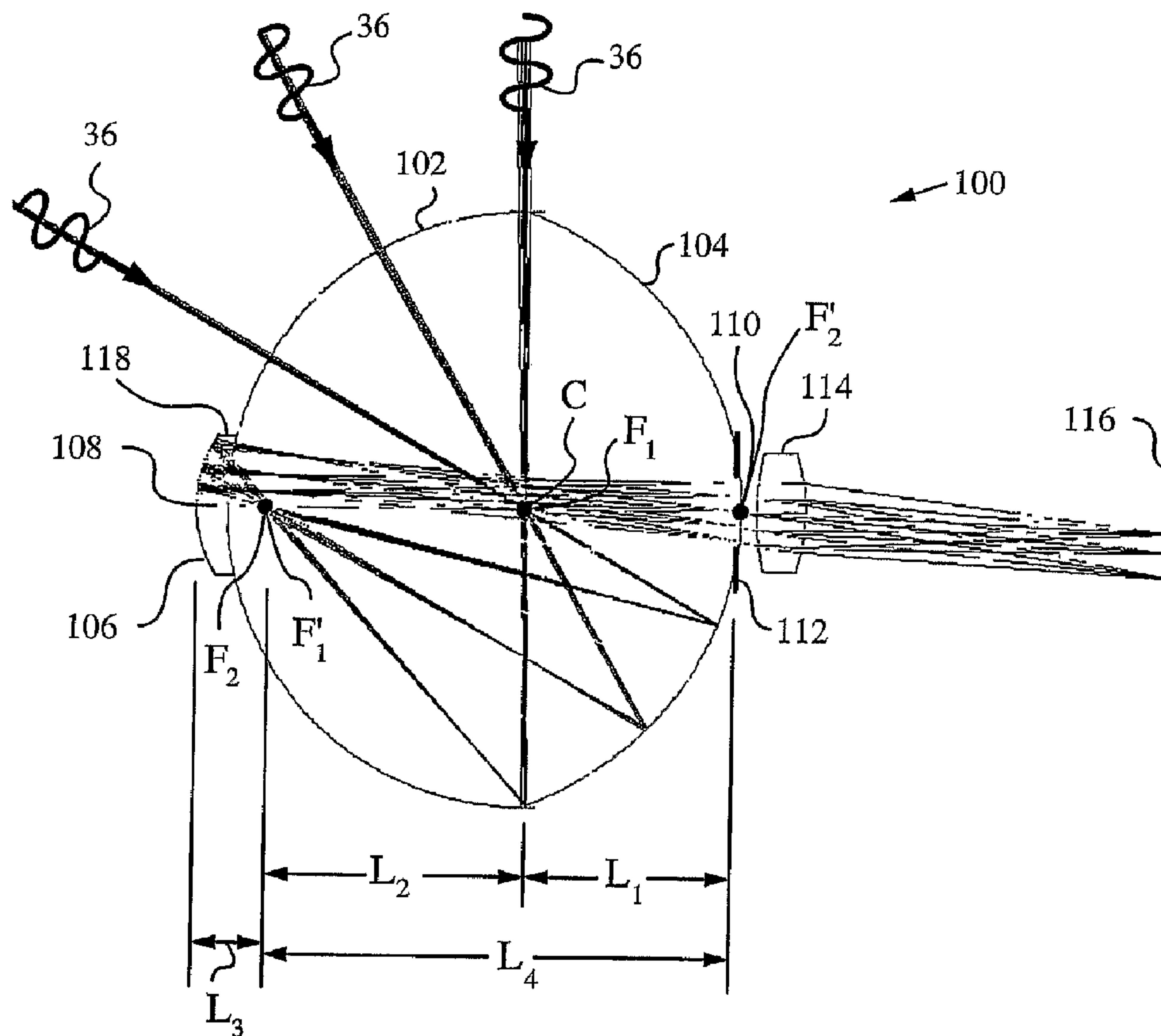

(86) Date de dépôt PCT/PCT Filing Date: 2004/11/24
 (87) Date publication PCT/PCT Publication Date: 2005/06/09
 (85) Entrée phase nationale/National Entry: 2006/05/18
 (86) N° demande PCT/PCT Application No.: US 2004/039444
 (87) N° publication PCT/PCT Publication No.: 2005/052667
 (30) Priorité/Priority: 2003/11/24 (US10/721,194)

(51) Cl.Int./Int.Cl. *G02B 17/08* (2006.01),
G02B 13/06 (2006.01)
 (71) Demandeur/Applicant:
ELECTRONIC SCRIPTING PRODUCTS, INC., US
 (72) Inventeur/Inventor:
MANDELLA, MICHAEL J., US
 (74) Agent: BERESKIN & PARR

(54) Titre : OBJECTIF CATADIOPTRIQUE SOLIDE A POINT DE VUE UNIQUE
 (54) Title: SOLID CATADIOPTRIC LENS WITH A SINGLE VIEWPOINT



(57) Abrégé/Abstract:

A solid catadioptric lens (100) with a single viewpoint has a spherical refractive surface (102) with a center C on an optical axis of the lens. An ellipsoidal reflective surface (104) of the lens faces the spherical refractive surface such that a first focus F_1 of the ellipsoidal reflective surface is coincident with the center C of the spherical refractive surface. Furthermore, the lens has a shaping

(57) **Abrégé(suite)/Abstract(continued):**

surface (106) facing the ellipsoidal reflective surface for shaping a light that passes the single viewpoint. The shaping surface can be refractive, reflective or semi-transparent and its shape can be ellipsoidal with its first focus F_1' coincident with the second focus F_2 of the ellipsoidal reflective surface. The single viewpoint of the lens is at the center C of the spherical reflective surface and is enforced with an aperture (112) that can be positioned at various points inside, on a surface or even outside the lens, depending on the type of shaping surface chosen.

(12) INTERNATIONAL APPLICATION PUBLISHED UNDER THE PATENT COOPERATION TREATY (PCT)

(19) World Intellectual Property
Organization
International Bureau



(43) International Publication Date
9 June 2005 (09.06.2005)

PCT

(10) International Publication Number
WO 2005/052667 A1

(51) International Patent Classification⁷: **G02B 17/08**,
13/06

(21) International Application Number:
PCT/US2004/039444

(22) International Filing Date:
24 November 2004 (24.11.2004)

(25) Filing Language: English

(26) Publication Language: English

(30) Priority Data:
10/721,194 24 November 2003 (24.11.2003) US

(71) Applicant (for all designated States except US): **ELECTRONIC SCRIPTING PRODUCTS, INC.** [US/US]; c/o Lumen Intellectual Property Services, 2345 Yale Street, 2nd Floor, Palo Alto, CA 94306 (US).

(72) Inventor; and

(75) Inventor/Applicant (for US only): **MANDELLA, Michael, J.** [US/US]; 379 Sun Ridge Lane, San Jose, CA 95123 (US).

(74) Agent: **GU, Tianhua**; 2345 Yale Street, 2nd Floor, Palo Alto, CA 94306 (US).

(81) Designated States (unless otherwise indicated, for every kind of national protection available): AE, AG, AL, AM, AT, AU, AZ, BA, BB, BG, BR, BW, BY, BZ, CA, CH, CN, CO, CR, CU, CZ, DE, DK, DM, DZ, EC, EE, EG, ES, FI, GB, GD, GE, GH, GM, HR, HU, ID, IL, IN, IS, JP, KE, KG, KP, KR, KZ, LC, LK, LR, LS, LT, LU, LV, MA, MD, MG, MK, MN, MW, MX, MZ, NA, NI, NO, NZ, OM, PG, PH, PL, PT, RO, RU, SC, SD, SE, SG, SK, SL, SY, TJ, TM, TN, TR, TT, TZ, UA, UG, US, UZ, VC, VN, YU, ZA, ZM, ZW.

(84) Designated States (unless otherwise indicated, for every kind of regional protection available): ARIPO (BW, GH, GM, KE, LS, MW, MZ, NA, SD, SL, SZ, TZ, UG, ZM, ZW), Eurasian (AM, AZ, BY, KG, KZ, MD, RU, TJ, TM), European (AT, BE, BG, CH, CY, CZ, DE, DK, EE, ES, FI, FR, GB, GR, HU, IE, IS, IT, LU, MC, NL, PL, PT, RO, SE, SI, SK, TR), OAPI (BF, BJ, CF, CG, CI, CM, GA, GN, GQ, GW, ML, MR, NE, SN, TD, TG).

Published:

— with international search report

For two-letter codes and other abbreviations, refer to the "Guidance Notes on Codes and Abbreviations" appearing at the beginning of each regular issue of the PCT Gazette.

(54) Title: SOLID CATADIOPTRIC LENS WITH A SINGLE VIEWPOINT

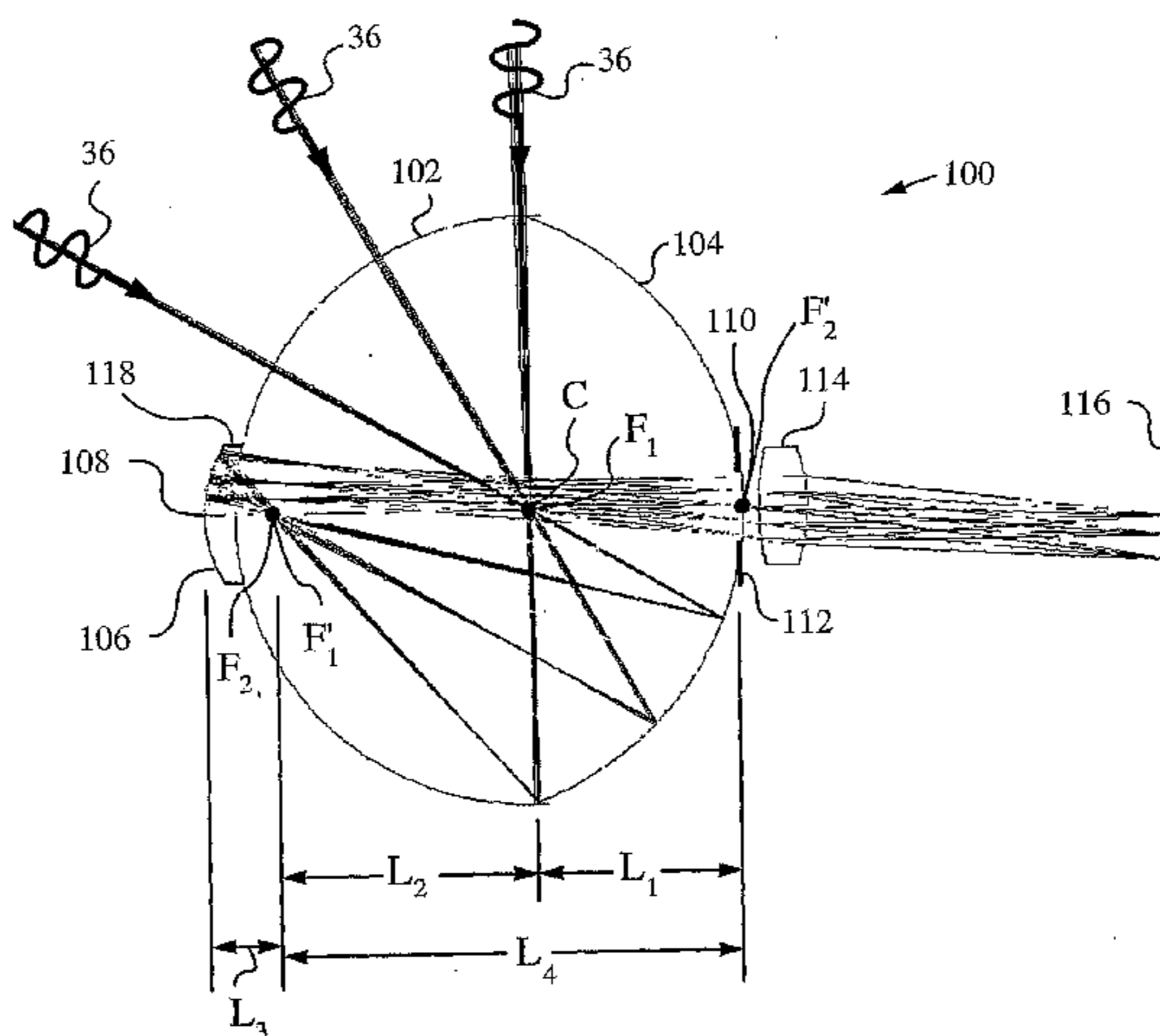

(57) Abstract: A solid catadioptric lens (100) with a single viewpoint has a spherical refractive surface (102) with a center C on an optical axis of the lens. An ellipsoidal reflective surface (104) of the lens faces the spherical refractive surface such that a first focus F_1 of the ellipsoidal reflective surface is coincident with the center C of the spherical refractive surface. Furthermore, the lens has a shaping surface (106) facing the ellipsoidal reflective surface for shaping a light that passes the single viewpoint. The shaping surface can be refractive, reflective or semi-transparent and its shape can be ellipsoidal with its first focus F_1' coincident with the second focus F_2 of the ellipsoidal reflective surface. The single viewpoint of the lens is at the center C of the spherical reflective surface and is enforced with an aperture (112) that can be positioned at various points inside, on a surface or even outside the lens, depending on the type of shaping surface chosen.

WO 2005/052667 A1

PATENT APPLICATION

5

of

Michael J. Mandella

10

for

Solid Catadioptric Lens with a Single Viewpoint**FIELD OF THE INVENTION**

15 The present invention relates generally to lenses for applications such as vision and imaging where a single viewpoint is required, and in particular to catadioptric lenses having a single viewpoint.

BACKGROUND OF THE INVENTION

20 Applications in computational vision such as ego-motion estimation and tracking often require imaging a large field of view. It is also desirable for an imaging system to have a single viewpoint in order to produce geometrically correct perspective images from the panoramic images
25 obtained from the imaging system. The single and fixed viewpoint constraint requires that an imaging system only capture light that is passing through a single point in three dimensional space, thus sampling the 5-dimensional plenoptic function at that point, which is known as the
30 effective viewpoint. Such imaging systems have been

realized by assemblies of curved mirrors and lenses. Although these catadioptric systems can have a large field of view and can satisfy the single viewpoint requirement they are cumbersome, expensive and large.

5

A number of wide field of view optics use facing mirrors to produce high quality images at the expense of an obscuration of the field of view. A simple example of a prior art optical system **10** of such type is shown in Fig. 1. System **10** has two facing mirrors **12**, **14** aligned on an optical axis **16**. Mirror **14** receives and reflects light from a scene **20** to mirror **12**. Mirror **12** reflects the light back to mirror **14** such that the light passes a central aperture **18** in mirror **14** and projects an image **22** of scene **20** on a screen **24**.

10
15

Mirror **12** obscures a cone-shaped central portion **26** of the field of view seen by mirror **14**. The result of this obscuration is a shadow **28** in image **22**. To be imaged, light arriving from scene **20** has to be incident on mirror **14** at an angle larger than the angle of cone **26**, e.g., at an angle of incidence θ_i relative to axis **16**.

20

The prior art contains teachings about telescopes and other systems that employ the above-described principles. For example, U.S. Pat. No. 5,089,910 to Sigler teaches a catadioptric zoom relay telescope with two mirrors of which the first mirror or primary mirror is aspheric. U.S. Pat. No. 5,940,222 to Sinclair et al. teaches catadioptric zoom lens assemblies employing these same principles.

25
30

Some applications such as robot vision and panoramic imaging require the optical system to have a single point of view or viewpoint. This condition enables the optical system to produce a perspective view of objects in its field of view. In some applications, it is further desirable to maximize the size of the field of view imaged from the single viewpoint.

It is difficult to satisfy all of the above conditions with a single system. The catadioptric zoom relay telescopes and lens assemblies are usually limited to a small field of view and many do not have a single viewpoint. In fact, many high quality systems offer excellent on-axis performance, e.g., as taught by Hicks in U.S. Pat. No. 6,412,961 but are inherently not single viewpoint. U.S. Pat. No. 5,473,474 to Powell teaches a panoramic lens that images a large field of view but lacks a single viewpoint. Still another approach using the facing mirrors configuration is taught by Kuroda et al. in U.S. Pat. No. 5,854,713. This patent describes a reflection type angle of view transforming optical apparatus that is hollow but also lacks a single viewpoint. Of further interest is the catadioptric system of Charles shown in U.S. Pat. No. 6,449,103. Additional references of interest include U.S. Pat. No. 4,566,763 teaching the use of a parabolic reflector and U.S. Application No. 2003/0142203 teaching the use of a hyperbolic reflector.

The prior art does teach some systems that have a single viewpoint. For example, U.S. Pat. No. 3,505,465 to Rees discloses how to use a hyperbolic mirror to produce a

single viewpoint system for a person viewing an image such as a TV or video image produced, e.g., by a video camera. More recently, Patent Nos. 5,760,826 and 6,118,474 to Nayar describe an imaging apparatus for imaging a scene with a
5 substantially paraboloid-shaped reflector whose focus is coincident with the single viewpoint. The imaging apparatus has a telecentric means optically coupled to the paraboloid-shaped reflector for filtering out principal rays of electromagnetic radiation that are not
10 orthographically reflected by the paraboloid-shaped reflector.

Unfortunately, none of the prior art teachings provide a compact, effective and easy to manufacture single viewpoint
15 lens that can be used in vision systems requiring a panoramic projection or perspective view of objects distributed over a large field of view.

OBJECTS AND ADVANTAGES

20 In view of the above, it is an object of the invention to provide a compact, effective, rugged and easy to manufacture catadioptric lens with a single viewpoint and a large field of view. In particular, it is an object of the invention to provide a single viewpoint catadioptric lens
25 that can be used in vision systems such as vision systems requiring a panoramic projection.

These and other objects and advantages of the invention will become apparent upon reading the ensuing description.

SUMMARY OF THE INVENTION

The objects and advantages of the invention are secured by a solid catadioptric lens with a single point of view or viewpoint. The lens has an optical axis and a spherical refractive surface with a center C on the optical axis. 5 The lens has an ellipsoidal reflective surface facing the spherical refractive surface arranged such that a first focus F_1 of the ellipsoidal reflective surface is coincident with the center C of the spherical refractive surface. The single viewpoint of the lens is at the center C of the spherical reflective surface. Further, the lens has a shaping surface facing the ellipsoidal reflective surface for shaping a light that passes the single viewpoint.

15

In one set of embodiments the shaping surface is a refractive shaping surface and the lens has an aperture for enforcing the single viewpoint at center C. The aperture is positioned at a second focus F_2 of the ellipsoidal reflective surface. The lens is constructed such that the second focus F_2 of the ellipsoidal reflective surface is on the optical axis, like first focus F_1 .

20

In some embodiments where the shaping surface is a refractive shaping surface, the second focus F_2 is located near or even on the refractive shaping surface. In some other embodiments using a refractive shaping surface, the second focus F_2 is inside the lens. The refractive shaping surface can assume a variety of shapes, but it is preferably ellipsoidal, thus forming an ellipsoidal refractive shaping surface. For light shaping reasons, it

30

is also preferred that the ellipsoidal refractive shaping surface have its first focus F_1' coincident with the second focus F_2 of the ellipsoidal reflective surface. In some embodiments, it is also convenient that the ellipsoidal refractive shaping surface have a conic constant K_2 equal to a conic constant K_1 of the ellipsoidal reflective surface.

In another set of embodiments the shaping surface is a reflective surface and an aperture is used for enforcing the single viewpoint. For example, in some embodiments in this set the aperture is positioned on the ellipsoidal reflective surface. In alternative embodiments, the aperture is positioned beyond the ellipsoidal reflective surface. Again, for light shaping reasons the reflective surface is preferably a second ellipsoidal reflective shaping surface. Furthermore, in some specific embodiments the second ellipsoidal reflective shaping surface has a first focus F_1' coincident with the second focus F_2 of the ellipsoidal reflective surface. In some of these specific embodiments the second ellipsoidal reflective shaping surface has a conic constant K_2 equal to the conic constant K_1 of the ellipsoidal reflective surface.

It should be noted that whether the shaping surface is refractive or reflective it can assume various shapes including conic sections. Alternatively, the shaping surface can be flat. Furthermore, the shaping surface does not have to be only refractive or reflective; it can be semi-transparent.

The solid catadioptric lens is preferably made of a optical material with an index n . Suitable materials include glasses, plastics and other well-known optical materials.

5 The invention further provides for a single viewpoint vision system. The vision system employs the solid catadioptric lens for shaping light passing through the single viewpoint. It should be noted that the vision system can be used for projecting light or for collecting
10 light for functions such as scanning or imaging, respectively. In embodiments where the lens is used for imaging, an imaging element can be provided for imaging the light onto an imaging unit or screen in an imaging plane. In scanning applications a scanning arrangement is
15 provided.

In some embodiments an optical relay is used for passing the light from the lens to the application. For example, an optical relay can be used to pass the light to an
20 imaging plane when the lens is deployed in an imaging vision system. In scanning vision systems, an optical relay can be used to deliver light from a scan element, e.g., a scan mirror to the lens.

25 The details of the invention will now be explained in the detailed description with reference to the attached drawing figures.

BRIEF DESCRIPTION OF THE DRAWINGS

30 Fig. 1 (Prior art) is a three-dimensional diagram illustrating a class of off-axis optical systems.

- Fig. 2 is a cross-sectional side view of one embodiment of a lens according to the invention.
- Fig. 3 is a cross-sectional side view of the lens of Fig. 2 used in imaging.
- 5 Fig. 4 is a cross-sectional side view illustrating another embodiment of a lens according to the invention.
- Fig. 5 is a cross-sectional side view of a lens according to the invention with folded geometry.
- 10 Fig. 6 is a cross-sectional side view of another lens with folded geometry.
- Fig. 7 is a cross-sectional side view of a folded lens used for projecting or imaging.
- Fig. 8 is a three-dimensional diagram showing a vision system having an imaging element and employing the lens of Fig. 7.
- 15 Fig. 9 is cross-sectional side view showing another vision system having a scanning arrangement and employing the lens of Fig. 7.
- 20 Fig. 10 is a cross-sectional side view of yet another lens according to the invention.
- Fig. 11 is a cross-sectional side view of the lens similar to the one shown in Fig. 2 with an optical relay.

25

DETAILED DESCRIPTION

The present invention will be best understood by first referring to an embodiment of a single viewpoint solid catadioptric lens **30** as shown in Fig. 2 in cross-sectional side view. Lens **30** has an optical axis **32** and is made of an optical material of index n . Preferably, the optical

30

material is uniform and exhibits substantially no or very little variation of index n . Suitable materials include glasses and plastics, such as moldable plastics and other optical materials.

5

Lens **30** has a spherical refractive surface **34** with a center C on optical axis **32**. A light **36** propagating to and a light **36'** propagating from center C traverses spherical refractive surface **34** at normal incidence. Spherical refractive surface **34** defines a solid angle Θ over which lens **30** gathers light **36** and into which lens **30** projects light **36'**.

Lens **30** has an ellipsoidal reflective surface **38** facing spherical refractive surface **34**. Ellipsoidal reflective surface **38** can be made reflective by providing it with a reflective coating or film **40**, as shown in this embodiment, or by other means. Ellipsoidal reflective surface **38** is created by revolving a mathematical ellipse, as shown in dashed lines **38'**. Specifically, surface **38** is defined by revolving ellipse **38'** about optical axis **32**. Surface **38** is oriented such that a first focus F_1 is coincident with center C of spherical refractive surface **34** on optical axis **32**. Second focus F_2 defined by surface **38** is also on optical axis **32** and within lens **30**.

Lens **30** has a shaping surface **42** facing ellipsoidal reflective surface **38** for shaping light **36**, **36'** passing through center C. In fact, center C is the point of view or viewpoint of lens **30**. An aperture **44** is provided to ensure that center C is the only viewpoint of lens **30**. In

other words, aperture **44** enforces the single viewpoint of lens **30**. Preferably, aperture **44** is formed by an object embedded in the optical material of lens **30** and having a pin-hole or diaphragm at second focus F_2 . Alternatively,
 5 aperture **44** is defined in a non-transparent section of the optical material of lens **30**. A person skilled in the art will appreciate that there are many alternative ways of defining aperture **44**.

10 Shaping surface **42** can assume any shape and be located at any position past or even at aperture **44**, as found suitable for shaping light **36**, **36'** for a given application. In the present embodiment shaping surface **42** is a refractive
 15 shaping surface for passing light **36**, **36'** in and out of lens **30**. In fact, refractive shaping surface **42** is an ellipsoidal refractive shaping surface formed by revolving a mathematical ellipse **42'**, as shown in dashed lines, about optical axis **32**. For light shaping reasons, it is preferred that ellipsoidal refractive shaping surface **42**
 20 have its first focus F_1' coincident with second focus F_2 defined by surface **38**, and its second focus F_2' on optical axis **32** within lens **30**. Even more preferably, surface **42** has a conic constant K_2 equal to:

25
$$K_2 = -\frac{1}{n^2},$$

where n is the index of the optical material. Under these circumstances, light **36** entering lens **30** over solid angle Θ emerges from lens **30** through surface **42** in a direction
 30 substantially parallel to optical axis **32**. It is further

possible to set a conic constant K_1 of surface **38** equal to conic constant K_2 , as in the present embodiment.

A plate **46** is placed before lens **30**. When lens **30** collects
5 light **36** arriving at an angle of incidence θ_i to optical
axis **32**, then plate **46** can be a screen for projecting light
36 thereon. In this mode lens **30** can be used for imaging.
Alternatively, plate **46** emits light **36'** substantially
parallel to optical axis **32** into lens **30**. In this mode
10 lens **30** projects light **36'** into solid angle Θ and can be
used for projecting an image.

The operation of lens **30** for imaging a wide field of view
is explained with reference to the cross-sectional side
15 view of Fig. 3. The field of view is defined by solid
angle Θ over which lens **30** gathers light **36**. Note that
angle Θ is symmetric about optical axis **32**.

Lens **30** is positioned such that its single viewpoint at
20 center C is at a height h above an object plane **48**. A
number of object points P_1, P_2, P_3, P_4 are located on object
plane **48** (points P_3 and P_4 are far away from optical axis
32 on plane **48**). Light **36** emanates from object plane **48**
and propagates in ray bundles **50, 52, 54** and **56** to lens **30**.
25 Point P_1 lies at one edge of the field of view such that
ray bundle **50** emanating from it enters lens **30** at minimum
incidence angle θ_{\min} . Point P_4 lies at the other edge of
the field of view such that ray bundle **56** emanating from it
enters lens **30** at maximum incidence angle θ_{\max} . The design
30 of lens **30** enables maximum incidence angle θ_{\max} to be
nearly 90° . Ray bundles **50** and **56** are drawn in dashed

lines to indicate that they bound the field of view of lens
30.

Ray bundles 50, ... 56 enter lens 30 via spherical refractive
5 surface 34. They then pass through the single point of
view at center C and propagate to reflective ellipsoidal
surface 38. At surface 38 ray bundles 50, ... 56 are
reflected to ellipsoidal refractive shaping surface 42.
Aperture 44 enforces the single point of view by allowing
10 ray bundles 50, ... 56 to continue propagating to ellipsoidal
refractive shaping surface 42 while stopping light that
enters via spherical refractive surface 34 but does not
pass through the single point of view at center C.

15 Since conic constants K_1 and K_2 of surfaces 38 and 42 are
equal, and $K_1=K_2=-1/n^2$, and foci F_2 and F_1' coincide, light
36 of ray bundles 50, ... 56 is substantially parallel to
optical axis 32 upon exiting lens 30. This is a desirable
type of shaping because ray bundles 50, ... 56 are projected
20 onto image plane 46 without requiring further optical
shaping. Points $P_1, \dots P_4$ on object plane 48 are thereby
imaged to corresponding imaged points $P_1', \dots P_4'$ on image
plane 46.

25 An advantageous feature of lens 30 is that ray bundles 50,
... 56 impinging on refractive surface 34 at equal angular
intervals or field angles are mapped substantially linearly
to distances from optical axis 32 when exiting ellipsoidal
refractive shaping surface 42. This means that object
30 points $P_1, \dots P_4$ at equal field angles are mapped to imaged
points $P_1', \dots P_4'$ at substantially equal separations from

each other in image plane **46**. The substantially linear map between field angle and distance from optical axis in image plane **46** is useful in many imaging applications and is sometimes referred to as $f-\theta$ imaging.

5

Fig. 4 is a cross-sectional side view of another embodiment of a single viewpoint catadioptric lens **60**. Lens **60** is made of a moldable plastic of index n and has a spherical refractive surface **62** with a center C on an optical axis **64**. Surface **62** faces an ellipsoidal reflective surface **66**. The two surfaces are arranged such that a first focus F_1 defined by surface **66** coincides with center C . A shaping surface **68** faces surface **66**. In this embodiment shaping surface **68** is reflective and is parabolic-shaped, thus forming a paraboloid reflective shaping surface. Surface **68** is defined by a single focus F_1' lying on optical axis **64**. Moreover, focus F_1' coincides with a second focus F_2 of surface **66**. In this embodiment conic constants K_1 and K_2 of surfaces **66** and **68** are not equal.

20

Lens **60** has an aperture **70** for enforcing the single viewpoint at center C . Since light cannot pass through paraboloid reflective shaping surface **68**, aperture is positioned at facing surface **66**. In the present embodiment aperture **70** is defined in or on ellipsoidal reflective surface **66**. For example, aperture **70** is a pin-hole in a reflective coating or film covering surface **66**. Alternatively, aperture **70** can be placed beyond surface **66** or before it.

30

A projecting unit **72** for emitting light **36'** is positioned behind surface **66** and centered on optical axis **64**. Unit **72** can be an array of light emitters and is used herein to illustrate the application of lens **60** for projecting light **36'** into the field of view indicated by angle Θ . The field of view defines a minimum emission angle σ_{\min} and a maximum emission angle σ_{\max} . Unit **72** emits light **36'** from its emitters such as a pixel **74** far enough from optical axis **64** to map to an emission angle σ such that $\sigma_{\min} < \sigma < \sigma_{\max}$. For example, light **36'** emitted from a pixel **74** at a distance d to optical axis **64**, is admitted into lens **60** through aperture **70** and emitted at emission angle σ . A person skilled in the art will recognize that additional optical elements such as lenses and mirrors can be placed between surface **66** and unit **72** for performing various light shaping and guiding functions as may be required for any particular application.

In one application, lens **60** is used for projecting light **36'** into its field of view. Unit **72** activates pixel **74** for emitting light **36'** at emission angle σ to optical axis **64**. Light **36'** propagates parallel and offset by distance d to optical axis **64** and is admitted into lens **60** via aperture **70**. The light guiding properties of lens **60** map light **36'** to angle σ as it exits lens **60** through spherical refractive surface **62**.

In another application lens **60** is used for collecting light **36** arriving from the field of view, e.g., at an angle of incidence $\theta_i = \sigma$, where angle of incidence θ_i is larger than a

minimum incidence angle $\theta_{\min.} = \alpha_{\min.}$ and smaller than a maximum incidence angle $\theta_{\min.} = \alpha_{\max.}$.

The geometry of the single viewpoint catadioptric lens of the invention can be modified in many ways. For example, the ellipsoidal surfaces of the lens can be folded. Fig. 5 illustrates an embodiment of a folded single viewpoint catadioptric lens **80** having external profiles **82** and **84**. Lens **80** has a spherical refractive surface **86** with a center **C** coincident with the single viewpoint. An ellipsoidal reflective surface **88** having a first focus F_1 and a second focus F_2 faces surface **86** and its first focus F_1 is coincident with center **C**. A shaping surface **90**, here in the form of a second reflective ellipsoidal shaping surface having first and second foci F_1' , F_2' faces surface **86**. All foci are on an optical axis **87**.

Ellipses **92**, **94** that are revolved to form surfaces **88** and **90** are indicated in dashed lines for clarification. In contrast to previous embodiments, ellipse **94** has its second focus F_2' on the other side of the viewpoint or center **C** and even beyond surface **88**. The overlap of ellipses **92**, **94** and surfaces **88**, **90** created by their revolution produces a geometry that is herein referred to as folded.

Second reflective ellipsoidal shaping surface **90** is formed on external profile **82** with the aid of a reflective coating or film (not shown). The size of surface **90** can be decreased to enlarge the field of view of lens **80**. External profile **84** extends from surface **88** and terminates at a flat coupling face **96**. Face **96** is transparent and located such

that second focus F_2' of surface **90** falls on it. In fact, the size of face **96** defines the aperture of lens **80** that enforces the single viewpoint at center C. If a small aperture is desired, then a mask can be supplied on face **96**
5 and a central opening in the mask can define the aperture.

To understand the operation of lens **80** we follow an incident ray bundle **98** of light **36** entering lens **80**, while realizing that lens **80** can also project light **36'**. Light
10 **36** enters lens **80** through surface **86**, passes single viewpoint at center C and is reflected by surface **88**. Light **36** then propagates to second focus F_2 as mathematics dictate that light passing through one focus of an ellipsoid and internally reflected converge at its second
15 focus. By design, second focus F_2 is coincident with first focus F_1' of surface **90** that is also ellipsoidal and thus enforces the same mathematical rule on light **36**. Specifically, light **36** is reflected from surface **90** and converges at second focus F_2' on coupling face **96**.

20
Light **36** is out-coupled through face **96** and may be further shaped, deflected and/or steered as required by the deployment conditions of lens **80**. For example, imaging elements can be positioned past face **96** to guide light **36**
25 into an image plane. Alternatively, optical relays can be positioned there to shape and guide light **36**.

Another folded geometry is embodied by a catadioptric lens **100** shown with its ray-trace in Fig. 6. The basic geometry
30 of lens **100** is described by nine geometric design parameters: R , R_1 , K_1 , R_2 , K_2 , L_1 , L_2 , L_3 , and L_4 . The first

five of these represent: radius of spherical refractive surface **102**, radius of curvature of ellipsoidal reflective surface **104**, conic constant of surface **104**, radius of curvature of second ellipsoidal reflective shaping surface **106**, conic constant of surface **106**. Parameters L_1 , L_2 , L_3 , and L_4 correspond to lengths as shown. Additionally, **108** is an apex of surface **106**, **110** is an apex of surface **104**, and **112** is an aperture enforcing the single viewpoint of lens **100**. Note that second focus F_2' of surface **106** falls on surface **104** within aperture **112**. Note that surface **106** is on an external profile **118** in this embodiment.

The design of lens **100** is a complete closed form solution. Thus, the optical performance of any vision system using lens **100** mostly depends on the design of its optical relay. In the present embodiment a single relay lens **114** represents an optical relay for producing images at a single wavelength of light **36** in an image plane **116**. A more achromatic optical relay with a field flattener can be used for color imaging, as will be appreciated by a person skilled in the art.

Lens **100** can be scaled to different sizes by changing the values of R , R_1 and R_2 . The general shape of lens **100** and its angular magnification is controlled by the ratio of the parameters K_1 and K_2 . Once these parameters have been adjusted, then the following equations are used to find L_1 , L_2 , L_3 and L_4 :

$$L_1 = R_1 \frac{[1 - \sqrt{-K_1}]}{1 + K_1};$$

30

$$L_2 = \frac{2R_1\sqrt{-K_1}}{1+K_1};$$

$$L_3 = \frac{R_2[1-\sqrt{-K_2}]}{1+K_2};$$

$$L_4 = \frac{2R_2\sqrt{-K_2}}{1+K_2}.$$

5 This ensures that the first geometrical focus F_1' of second
 ellipsoidal reflective shaping surface **106** is coincident
 with second geometrical focus F_2 of ellipsoidal reflective
 surface **104**. The present embodiment illustrates a special
 case where $L_4 = L_1 + L_2$, superposes second geometrical focus
 10 F_2' of second ellipsoidal reflective shaping surface **106** on
 apex **110** of ellipsoidal reflective surface **104**. As noted
 above, this causes aperture **112**, which may have a diameter
 of 2 mm or even less, depending on the desired light
 intensity, to fall on apex **110**. Preferably, aperture **112**
 15 is just a portion of ellipsoidal reflective surface **104**
 that is masked off before coating entire surface **104** with a
 reflective coating such as aluminum.

Fig. 7 illustrates still another folded single viewpoint
 20 lens **120** without any external profiles and a field of view
 described by solid angle Θ . Lens **120** has a spherical
 refractive surface **122** facing an ellipsoidal reflective
 surface **124** such that a center C of surface **122** is
 coincident with first focus F_1 of surface **124**. Surface **124**
 25 faces a semi-transparent ellipsoidal shaping surface **126**
 such that a second focus F_2 of surface **124** is coincident
 with a first focus F_1' of surface **126**. Second focus F_2' of
 surface **126** falls on surface **124** within an aperture **128**.

Center C and all foci are on an optical axis **130** of lens **120**.

An optical relay **132** is positioned next to surface **124** for
5 guiding light **36'** generated by a display unit **134** to lens
120. More precisely, relay **132** is a telecentric relay for
guiding light **36'** that propagates parallel to optical axis
130 into lens **120**. Relay **132** converts a distance d at
10 which light **36'** is offset from optical axis **130** to an
admission angle α into lens **120**. Reference f indicates a
focal length of relay **132**. By virtue of the design of
relay **132**, admission angle α is a substantially linear
function of distance d over small values of angle α .

15 During operation, a pixel **136** of display unit **134** offset by
distance d from optical axis **130** generates light **36'**.
Relay **132** guides light **36'** into lens **120** at admission angle
 α . Light **36'** is reflected from semi-transparent surface
126, surface **124** and then exits lens **120** at an emission
20 angle σ through surface **122**. During this process angle α
is "amplified" to angle σ and the angular magnification is
given by the ratio σ/α . A portion **138** of light **36'** exits
lens **120** via semi-transparent surface **126**. Portion **138** can
be used for monitoring the operation of lens **120** and/or
25 display unit **134**. Portion **138** can also be used for verify
alignment of lens **120** and display unit **134** or other
functions. A skilled artisan will appreciate that the
degree of transparency of semi-transparent surface **126** can
be adjusted depending on these functions. It should also
30 be noted that the transparency of semi-transparent surface
126 can depend on wavelength of light **36'**.

In an alternative embodiment, lens **120** operates in reverse by admitting light **36** and projecting it to pixel **136**. In this case display unit **134** is replaced by a light-sensing
5 element, e.g., an imaging element such as an imaging array. In such array pixel **136** is light-sensitive. Note that a portion of light **36** is also transmitted through semi-transparent surface **126**.

10 From the small sample of designs described above, it is clear that catadioptric lenses according to the invention are versatile, simple, rugged and easy to manufacture. They can be made in parts or as a whole part by techniques such as molding. Their optical performance depends largely
15 on the accuracy of the surfaces and the design of auxiliary optical relays that deliver light to or collect light from them. Such relays should be designed based on the vision system or application and specific design choices may depend on whether it is a system with an imaging element,
20 a scanning arrangement or a display element.

Fig. 8 illustrates a single viewpoint vision system **140** using lens **120** with a reflective ellipsoidal shaping surface **126'** rather than semi-transparent shaping surface
25 **126**. Vision system **140** has an imaging element **142**, e.g., an imaging array with pixels **144** (shown partially for clarity). Array **142** is positioned in an image plane **146** behind surface **124**. The optical relay between surface **124** and image plane **146** is not shown here for reasons of
30 clarity. However, any type of relay, including a

telecentric relay as described in Fig. 7, can be used between lens **120** and imaging array **142**.

Surface **126'** limits the field of view of lens **120** to the
5 off-axis region described by solid angle Θ . Therefore, vision system **140** is most useful when the center of the field of view is obscured or does not require imaging. The center of the field of view corresponds to shadow **148** in image plane **146**. For clarity of explanation, aperture **128**
10 for enforcing point of view C is not indicated on surface **124** and image plane **146** is shown enlarged.

Vision system **140** is directed at an arbitrary object **150** to be imaged. Herein, object **150** is a substrate whose surface
15 lies in an $X'-Y'$ plane of object coordinates (X',Y',Z') . Vision system **140** is above substrate **150** and the origin of object coordinates and single viewpoint C of lens **120** are connected by a vector R^c . Vector R^c is collinear with optical axis **130** and the norm of vector R^c is the distance
20 between the origin and viewpoint C. Vision system **140** moves in space and its coordinates (X,Y,Z) are rotated with respect to object coordinates (X',Y',Z') . Many conventions exist to align the object coordinates and vision system coordinates. For example, the rotation between vision
25 system coordinates (X,Y,Z) and object coordinates can be expressed by three consecutive rotations by Euler angles (φ, θ, ψ) .

During operation vision system **140** collects light **36**, such
30 as light **36** from a point P on substrate **150**. Light **36** propagates in a ray bundle **152** to enter lens **120** at angle

of incidence θ_i . Lens **120** images point P to an imaged point P^I on imaging array **142** in image plane **146**. Conveniently, image plane **146** is described by imaging array axes X^I and Y^I , and the location of imaged point P^I in image plane **146** is described by a vector R^P . Because of its single viewpoint C , lens **120** produces a panoramic projection of imaged point P^I . Thus, lens **120** can produce a panoramic image of object **150** in image plane **146**.

10 In a modified embodiment, vision system **140** can use lens **120** to project light **36'** to a projected point P_p on substrate **150** and collect light **36** from point P simultaneously. In this embodiment a pixel **154** at point P^S on array **142** produces light **36'**. The location of point P^S in image plane **146** is described by vector R^S . A ray bundle **156** of light **36'** is projected through lens **120** at emission angle σ onto substrate **150** to point P_p . Hybrid arrays having light sensitive and light-emitting pixels that can be employed in this embodiment are known in the art. Of course, a display unit such as the one shown in Fig. 7 can be used for projecting light **36'** if no imaging of substrate **150** is required.

Fig. 9 shows a vision system **160** employing lens **120** with a wavelength-dependent semi-transparent ellipsoidal shaping surface **126''** to project light **36'** on an object **162**. At certain points object **162** responds by producing a back-scattered light **36''** and system **160** simultaneously uses lens **120** to collect back-scattered light **36''**.

30

System **160** has a display unit **164**, e.g., a display screen or a detector array, in front of surface **126''**. Unit **164** is centered on optical axis **130**. Further, system **160** has a scanning arrangement **166** with a light source **168** for
5 generating light **36'**. Arrangement **166** has a scan mirror **170** for deflecting or steering light **36'**. Mirror **170** is tilted by a scan angle γ with respect to a mirror plane M_p . Drivers for controlling scan angle γ are well-known in the art.

10

Arrangement **166** has an optical relay **172** for shaping and directing light **36'** along optical axis **130** into lens **120** through aperture **128**. Relay **172** is of the type that converts scan angle γ to a corresponding admission angle α
15 into lens **120**. For example, relay **172** is a 4-f system using two lenses with the same or different focal lengths on axis **130** such that the center of mirror **170** is coincident with one focal point of relay **172** and second focus F_2' of surface **126''** is coincident with another focal
20 point of the 4-f system. Relay **172** also has a beam splitter **176** for deflecting any light returning to scanning arrangement **166** from lens **120**.

In operation, system **160** directs light **36'** by adjusting
25 scan angle γ of mirror **170**. A change in scan angle γ changes emission angle σ at which light **36'** exits lens **120**. In the present case scan angle γ is varied such that light **36'** is first emitted at angle σ_1 and then at σ_2 .

30 The pass wavelength of semi-transparent surface **126''** is chosen such that a small portion **174** of light **36'**, e.g., a

fraction of a percent, is transmitted and projected onto display unit **164**. Specifically, when light **36'** is emitted at angle σ_1 portion **174** is transmitted to point P_2' . Then, at angle σ_2 portion **174** is transmitted to point P_1' .
5 Portion **174** of light **36'** can be used for reference, feedback, tracking or other auxiliary functions.

At angle σ_2 object **162** produces back-scattered light **36''** that returns to lens **120** along the path of light **36'**.
10 Light **36''** enters lens **120** through surface **122** at an angle of incidence $\theta_i = \sigma_2$. A small fraction of light **36''** exits lens **120** via surface **126''**. The remainder of light **36''** is reflected by surface **126''** and is separated by beam-splitter **174**. Of course, if the fraction of light **36''** registered by
15 unit **164** is sufficient for monitoring back-scattered light **36''** then the remainder of light **36''** can be discarded. In those cases beam-splitter **174** can be removed.

Fig. 10 illustrates yet another embodiment of a single
20 viewpoint lens **180**. Lens **180** has a spherical refractive surface **182** facing an ellipsoidal reflective surface **184**, which in turn faces a flat refractive shaping surface **186**. First focus F_1 of surface **184** and center C of surface **182** are coincident at the single viewpoint of lens **180**. The
25 second focus F_2 of surface **184** is on surface **186** and within aperture **188** enforcing the single viewpoint.

Lens **180** is made of two materials **183**, **185** having indices n_1 , n_2 respectively. Material **183** is preferably a glass or
30 plastic, while material **185** is a glass or plastic, but could also be a liquid or optical gel filling a cavity in

lens **180**. In the latter case, a portion **190** of lens **180** indicated in dashed and dotted lines is made of a suitable material that can also be a glass or plastic forming an envelope to contain material **185**. It is preferable that
5 $n_1=n_2$.

An optical relay in the form of a compound lens **192** is positioned adjacent to surface **186** for out-coupling light **36** from lens **180**. In the present case lens **192** is designed
10 for projecting light **36** onto an image plane **194**. In reverse, lens **192** can be used for in-coupling light **36'** from image plane **194** into lens **180**.

Alternatively, lens **180** can be built with the aid of a
15 shell **196** indicated in dashed lines and defining an internal cavity **198**. Cavity **198** is filled, e.g., with an optical gel or other optical material. In fact, entire lens **180** including portion **190** can be a hollow form or shell filled with an optical material such as an optical
20 gel or liquid.

Fig. 11 is a cross-sectional side view of a lens **200** similar to lens **30** shown in Fig. 2 and equipped with an optical relay **210**. Lens **200** has a spherical refractive
25 surface **202**, a facing ellipsoidal reflective surface **204** and a refractive ellipsoidal shaping surface **206**. First focus F_1 of surface **204** and center C of surface **202** are coincident at the single viewpoint. Foci F_1' and F_2 are also coincident. All foci are on optical axis **208**.

30

Lens **200** differs from lens **30** in that it has no fixed aperture within its body. Rather, an adjustable aperture **212** is provided in optical relay **210** between lenses **214**, **216**. Lenses **214** and **216** have focal lengths f_1 and f_2 respectively. Relay **210** has a first image plane **218** at a distance equal to f_1 from lens **214**. A second image plane **220** is located at a distance equal to f_2 from lens **216**. A person skilled in the art will realize that relay **210** is a type of 4-f relay.

10

During operation aperture **212** can be adjusted to regulate the F-number of lens **200** and operate in a wide range of illumination conditions. It should be noted that opening aperture **212** to obtain a low F-number results in progressive deterioration of the single viewpoint property of lens **200**.

15

The single viewpoint catadioptric lens according to the invention admits of myriads of other embodiments. For example, it does not have to be a solid lens, but can also be hollow, e.g., in cases where it is made by molding. In some cases where certain regions of the lens are hollow cavities left by the fabrication method, these hollow cavities can be filled with an optical fluid or gel having an index of refraction matching that of the solid sections of the lens. In still other embodiments the ellipsoidal reflective surface and/or the shaping surface are counter-sunk within the lens rather than being on an external profile. Given all the alternative embodiments, the scope of the invention is to be judged by the following claims and their legal equivalents.

25

30

1 Claims:

2

- 3 1. A solid catadioptric lens having a single viewpoint on
4 an optical axis and comprising:
5 a) a spherical refractive surface having a center C on
6 said optical axis;
7 b) an ellipsoidal reflective surface facing said
8 spherical refractive surface and having a first
9 focus F_1 coincident with said center C, whereby
10 said center C is said single viewpoint; and
11 c) a shaping surface facing said ellipsoidal
12 reflective surface for shaping a light passing said
13 single viewpoint.

14

- 1 2. The solid catadioptric lens of claim 1, wherein
2 said shaping surface is a refractive shaping
3 surface and said solid catadioptric lens further
4 comprises an aperture for enforcing said single
5 viewpoint.

6

- 1 3. The solid catadioptric lens of claim 2, wherein
2 said aperture is positioned at a second focus F_2
3 of said ellipsoidal reflective surface.

4

- 1 4. The solid catadioptric lens of claim 3,
2 wherein said second focus F_2 is on said
3 optical axis and substantially at said
4 refractive shaping surface.

5

- 1 5. The solid catadioptric lens of claim 3,
2 wherein said second focus F_2 is on said

3 optical axis and inside said solid
4 catadioptric lens.

5

1 6. The solid catadioptric lens of claim 2, wherein
2 said refractive shaping surface is an
3 ellipsoidal refractive shaping surface.

4

1 7. The solid catadioptric lens of claim 6,
2 wherein said ellipsoidal refractive shaping
3 surface has a first focus F_1' coincident
4 with said second focus F_2 .

5

1 8. The solid catadioptric lens of claim 7,
2 wherein said ellipsoidal refractive shaping
3 surface has a conic constant K_2 equal to a
4 conic constant K_1 of said ellipsoidal
5 reflective surface.

6

1 9. The solid catadioptric lens of claim 1, wherein
2 said shaping surface is a reflective shaping
3 surface and said solid catadioptric lens further
4 comprises an aperture for enforcing said single
5 viewpoint.

6

1 10. The solid catadioptric lens of claim 9, wherein
2 said aperture is positioned at said ellipsoidal
3 reflective surface.

4

1 11. The solid catadioptric lens of claim 9, wherein
2 said aperture is positioned beyond said
3 ellipsoidal reflective surface.

4

1 12. The solid catadioptric lens of claim 9, wherein
2 said reflective shaping surface is a second
3 ellipsoidal reflective shaping surface.

4

1 13. The solid catadioptric lens of claim 12,
2 wherein said second ellipsoidal reflective
3 shaping surface has a first focus F_1'
4 coincident with said second focus F_2 .

5

1 14. The solid catadioptric lens of claim 12,
2 wherein said second ellipsoidal reflective
3 shaping surface has a conic constant K_2
4 equal to a conic constant K_1 of said
5 ellipsoidal reflective surface.

6

1 15. The solid catadioptric lens of claim 1 comprising
2 an optical material having an index n .

3

1 16. The solid catadioptric lens of claim 1, wherein
2 said shaping surface is a semi-transparent shaping
3 surface.

4

1 17. The solid catadioptric lens of claim 1, wherein
2 said shaping surface is selected from the group
3 consisting of a flat shaping surface, an
4 ellipsoidal shaping surface and a paraboloid
5 shaping surface.

6

1 18. A single viewpoint vision system comprising:

2 a) a solid catadioptric lens having an optical axis;

- 3 b) a spherical refractive surface having a center C on
4 said optical axis;
- 5 c) an ellipsoidal reflective surface facing said
6 spherical refractive surface and having a first
7 focus F_1 coincident with said center C, whereby
8 said center C is said single viewpoint; and
- 9 d) a shaping surface facing said ellipsoidal
10 reflective surface for shaping a light passing said
11 single viewpoint.

12

- 1 19. The single viewpoint vision system of claim 18,
2 further comprising an optical relay for passing
3 said light.

4

- 1 20. The single viewpoint vision system of claim 18,
2 wherein said shaping surface is selected from the
3 group consisting of reflective shaping surface,
4 refractive shaping surface and semi-transparent
5 shaping surface.

6

- 1 21. The single viewpoint vision system of claim 18,
2 wherein said shaping surface is selected from the
3 group consisting of a flat shaping surface, an
4 ellipsoidal shaping surface and a paraboloid
5 shaping surface.

6

- 1 22. The single viewpoint vision system of claim 18,
2 further comprising an element selected from the
3 group consisting of scanning arrangement, imaging
4 element and a display unit.

5

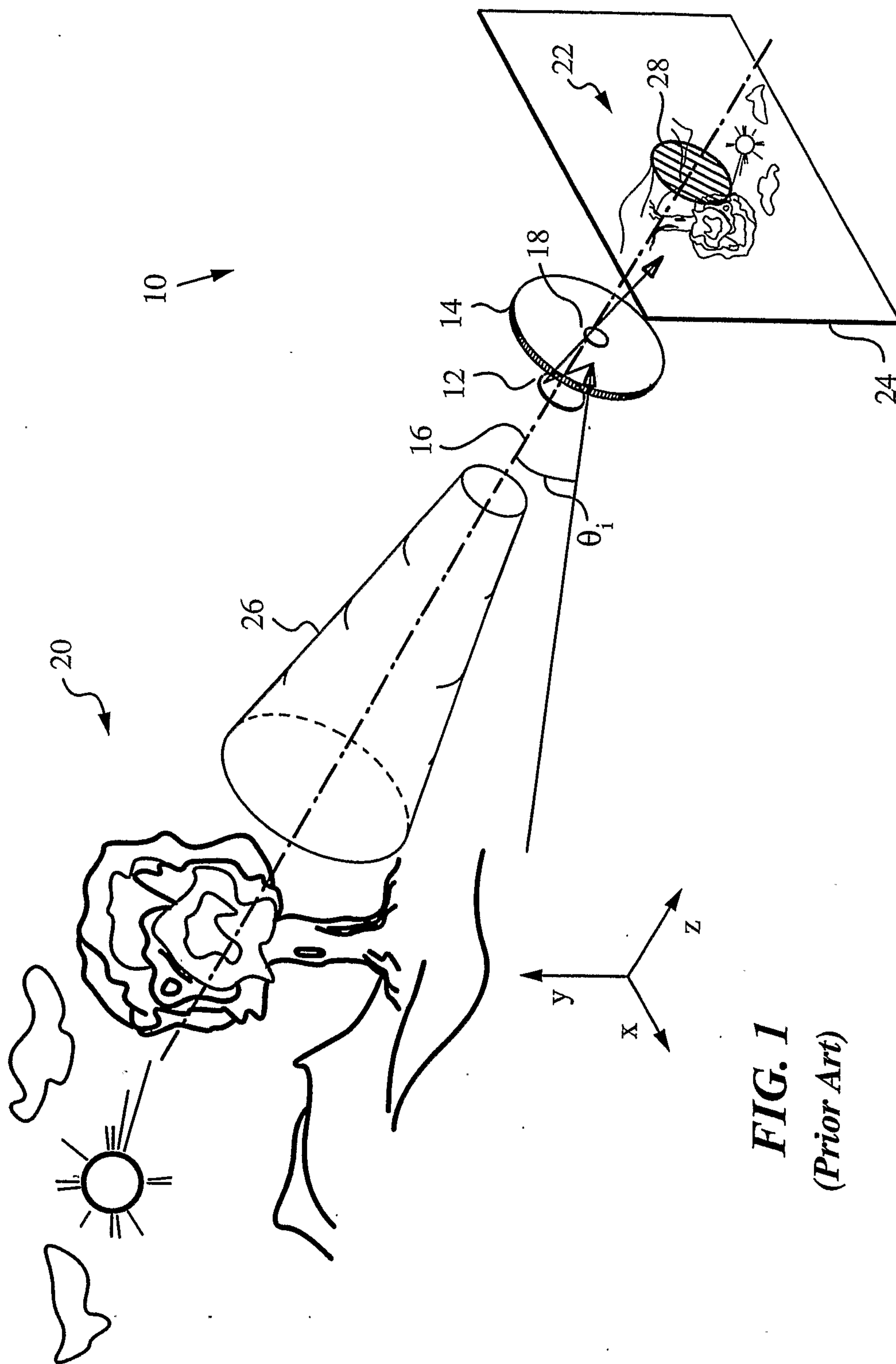

FIG. 1
(Prior Art)

2/10

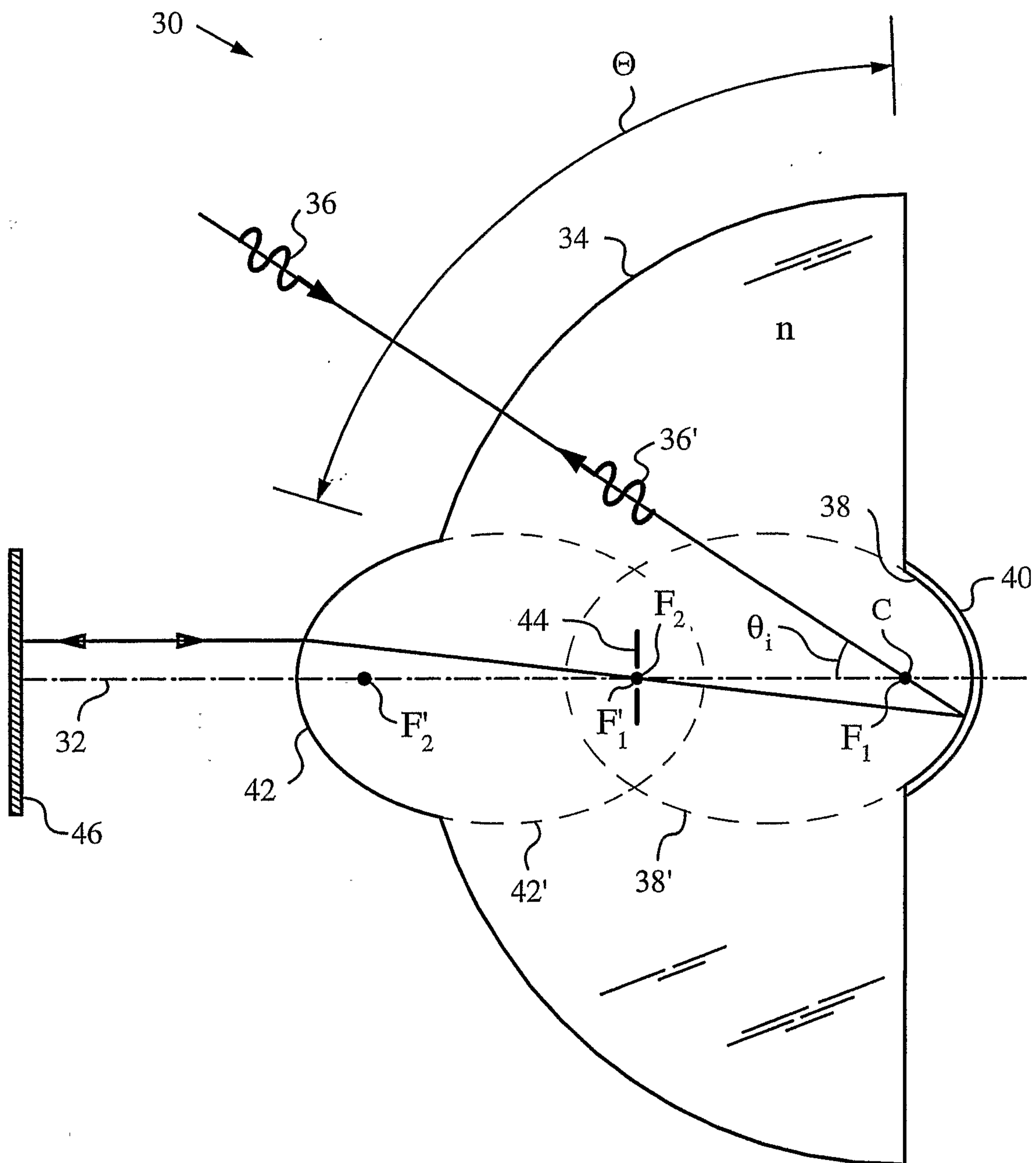

FIG. 2

3/10

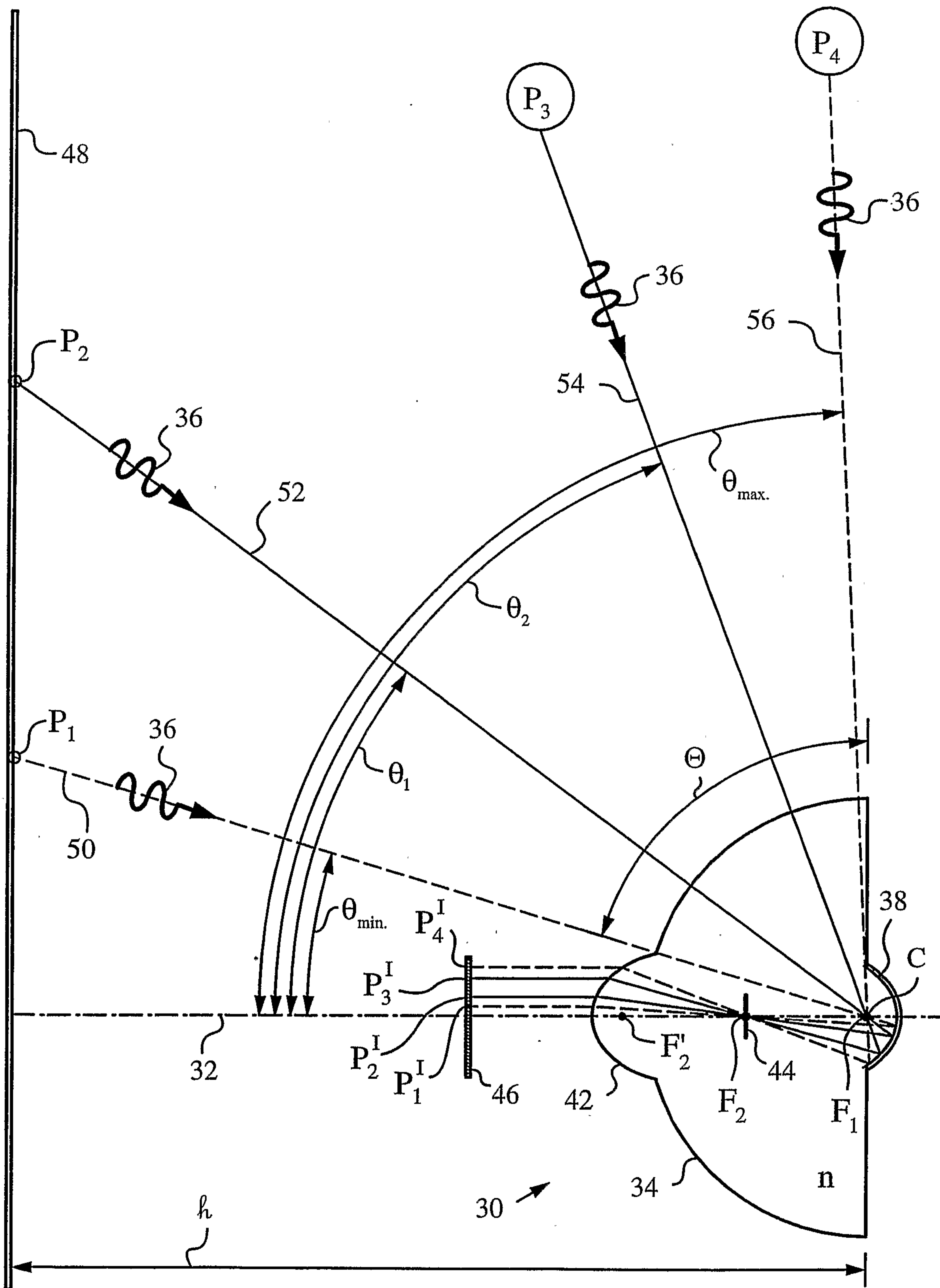

FIG. 3

4/10

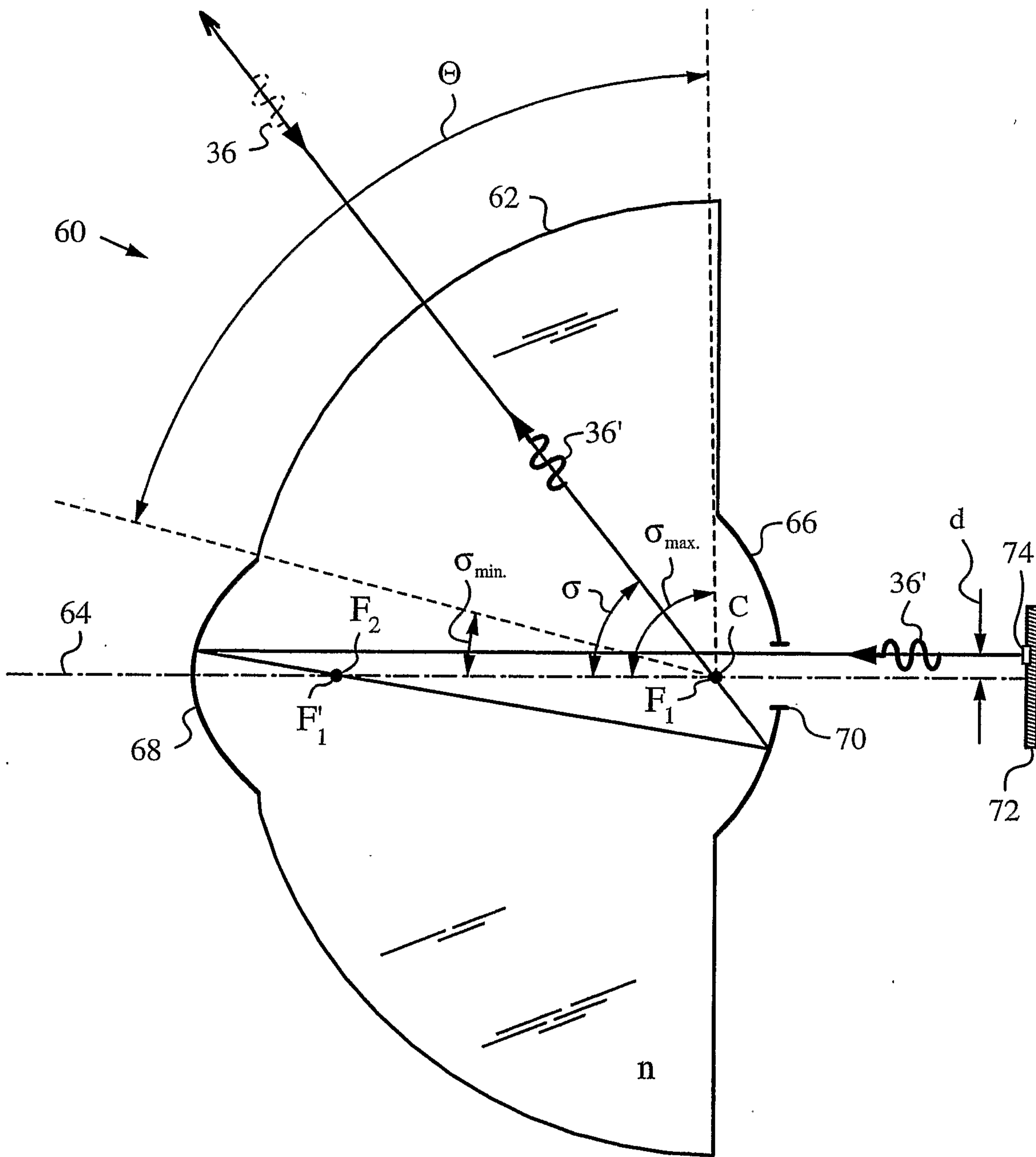

FIG. 4

5/10

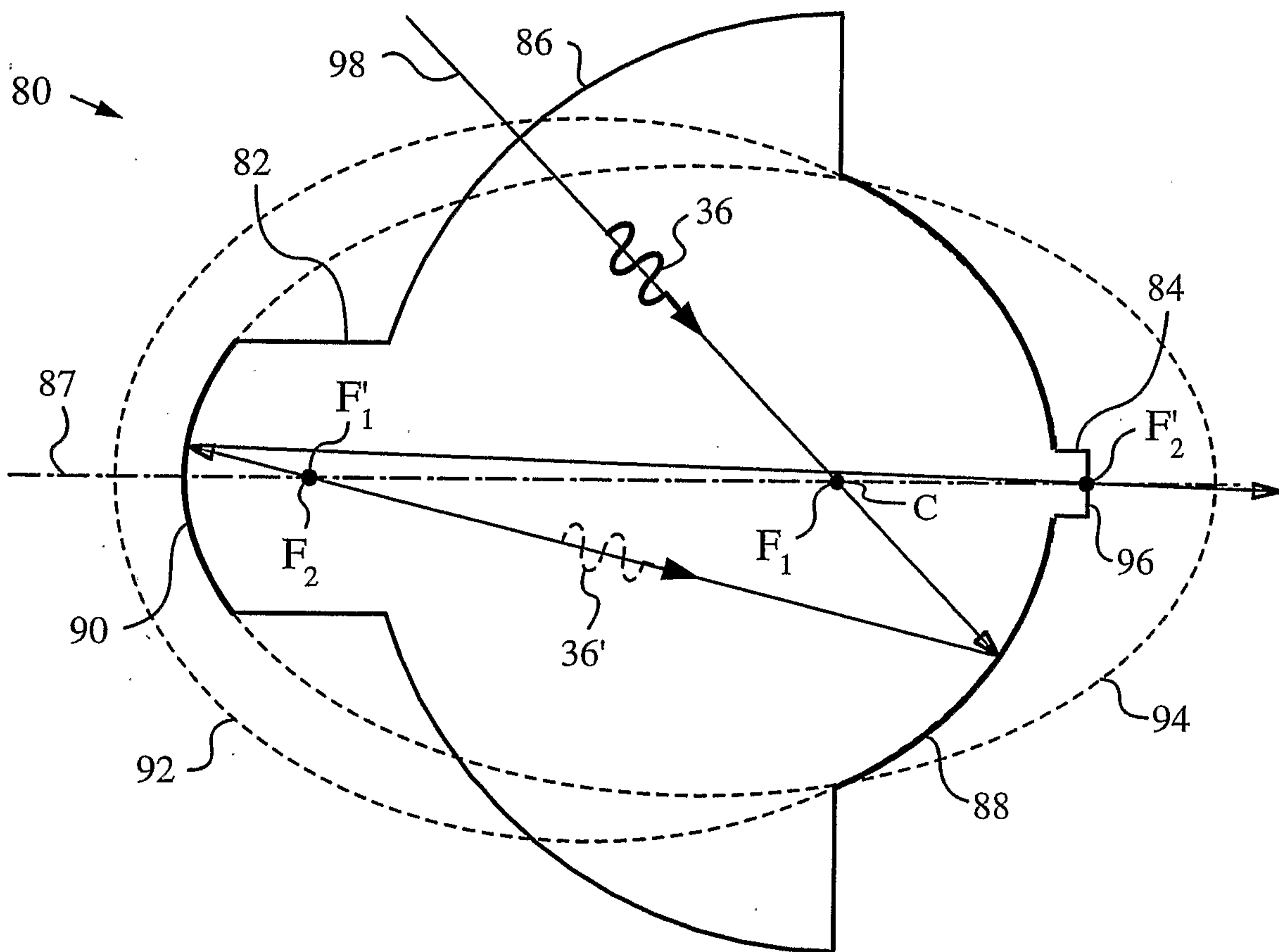

FIG. 5

6/10

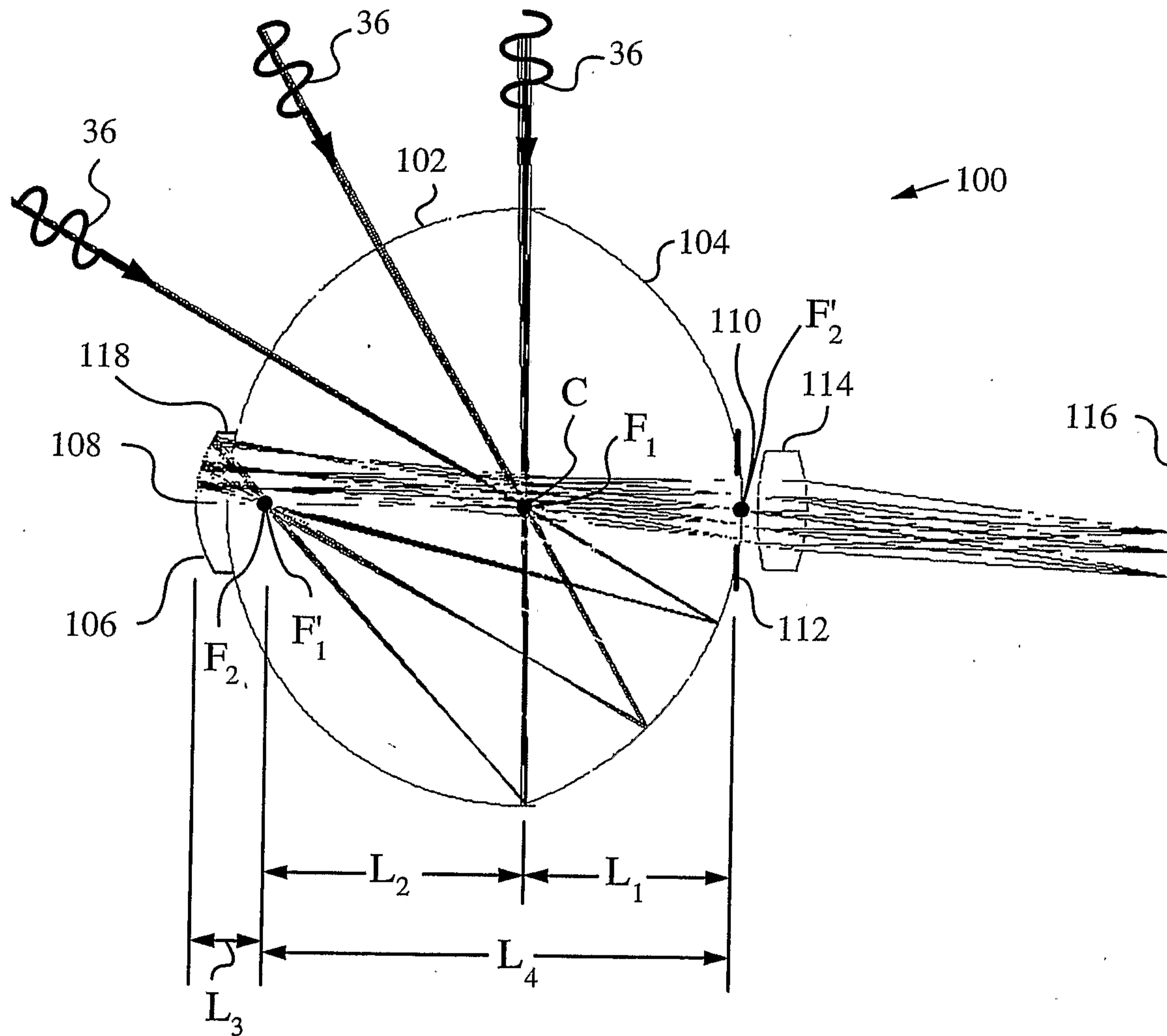

FIG. 6

7/10

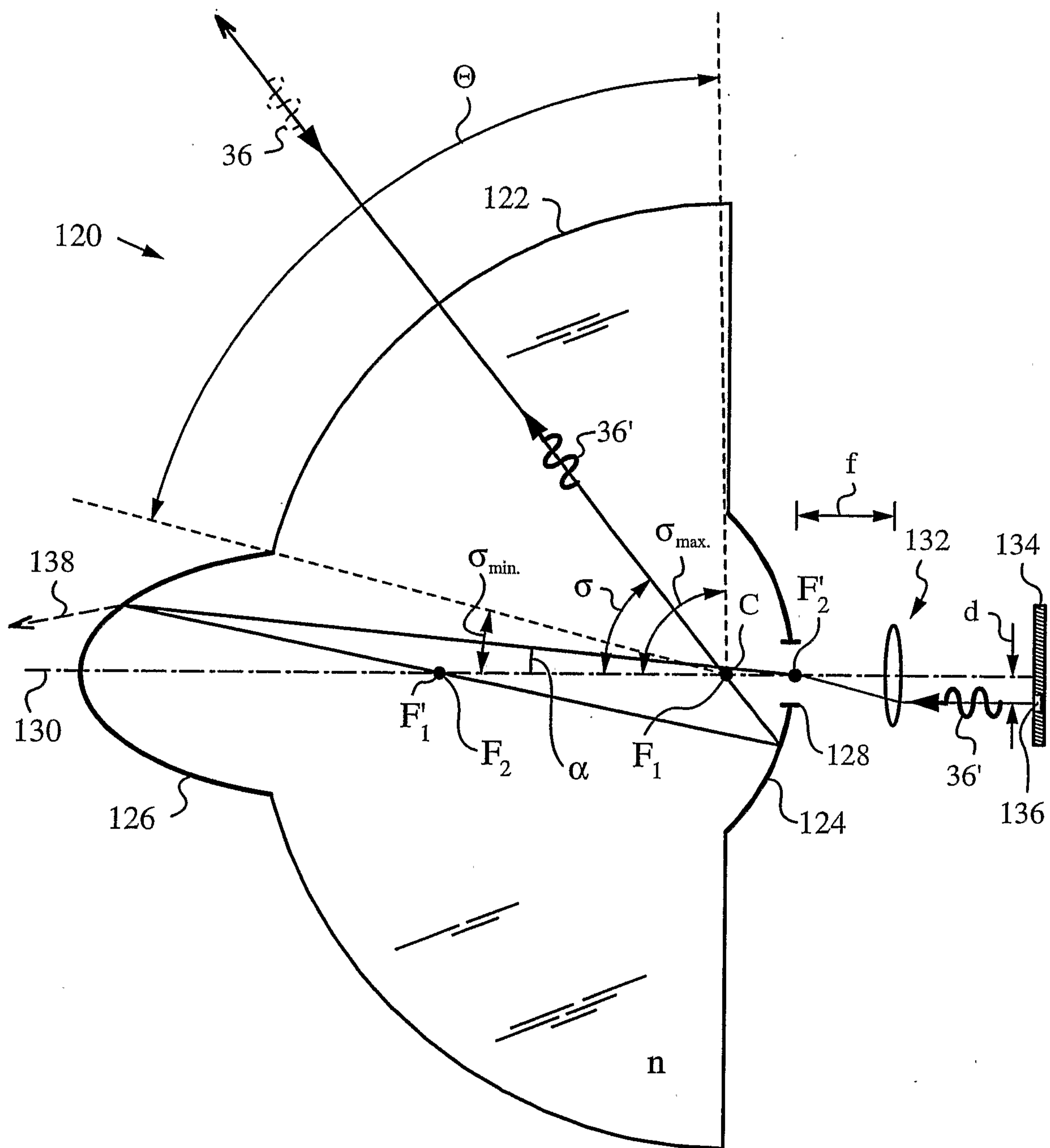

FIG. 7

8/10

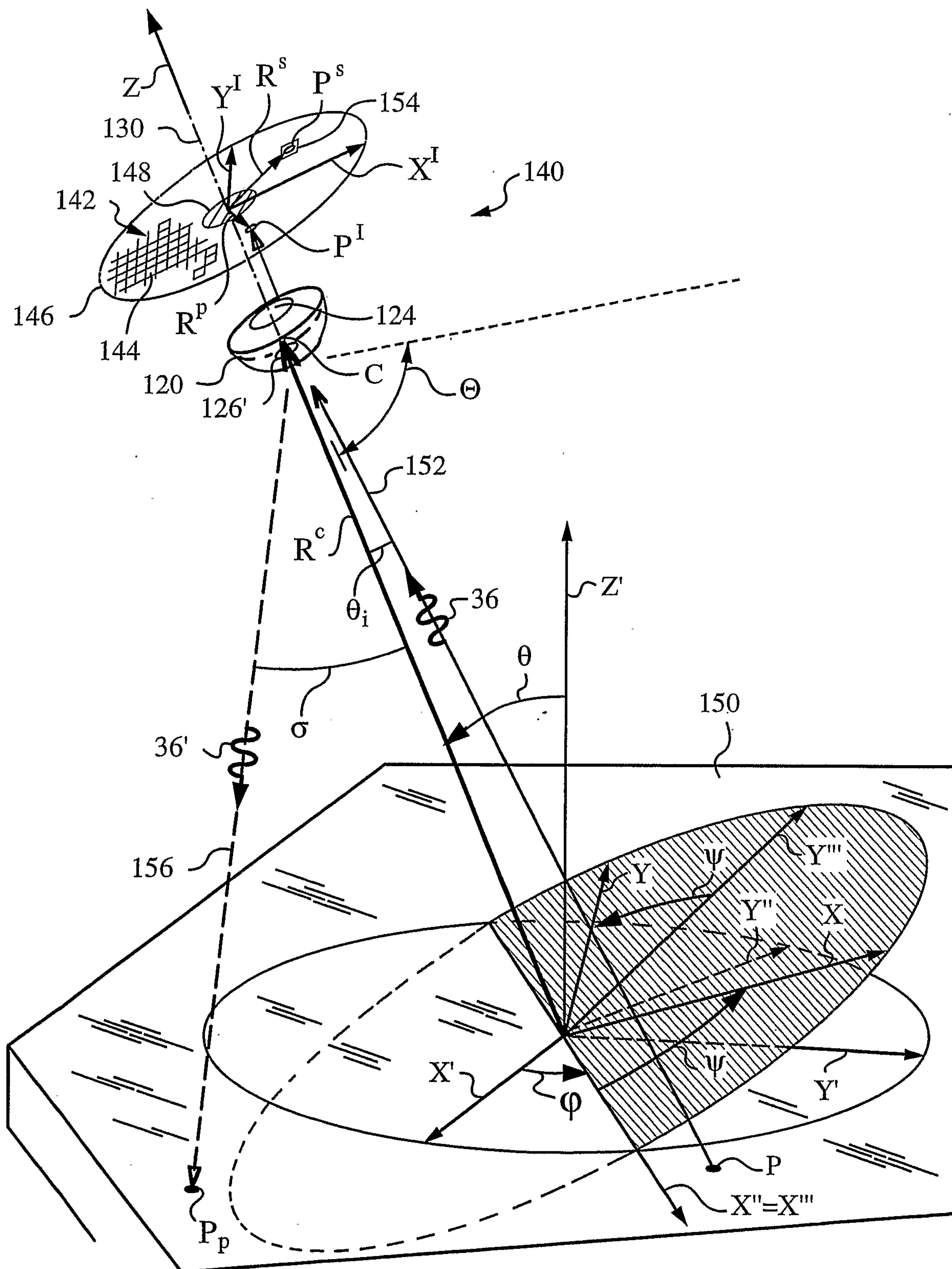

FIG. 8

9/10

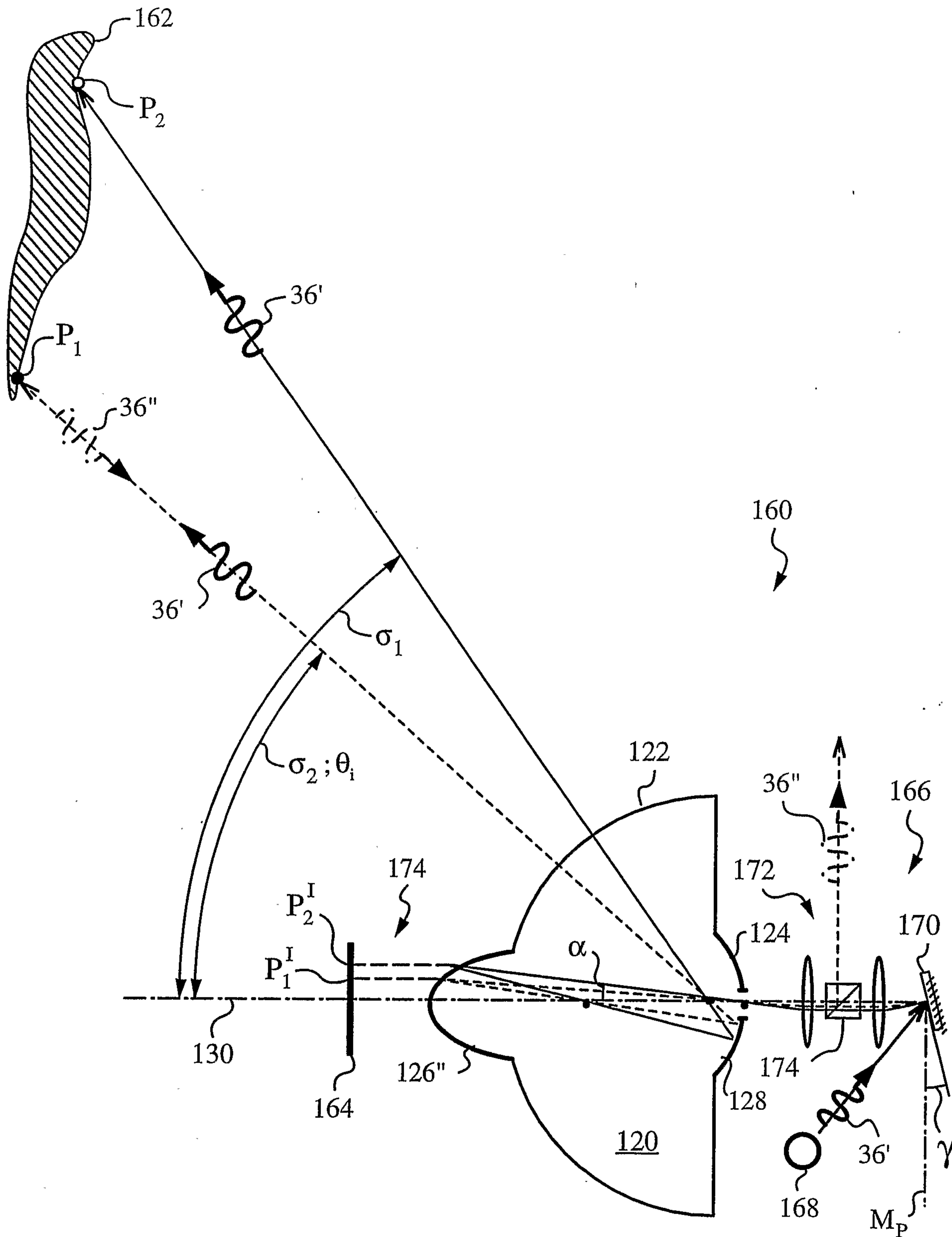

FIG. 9

10/10

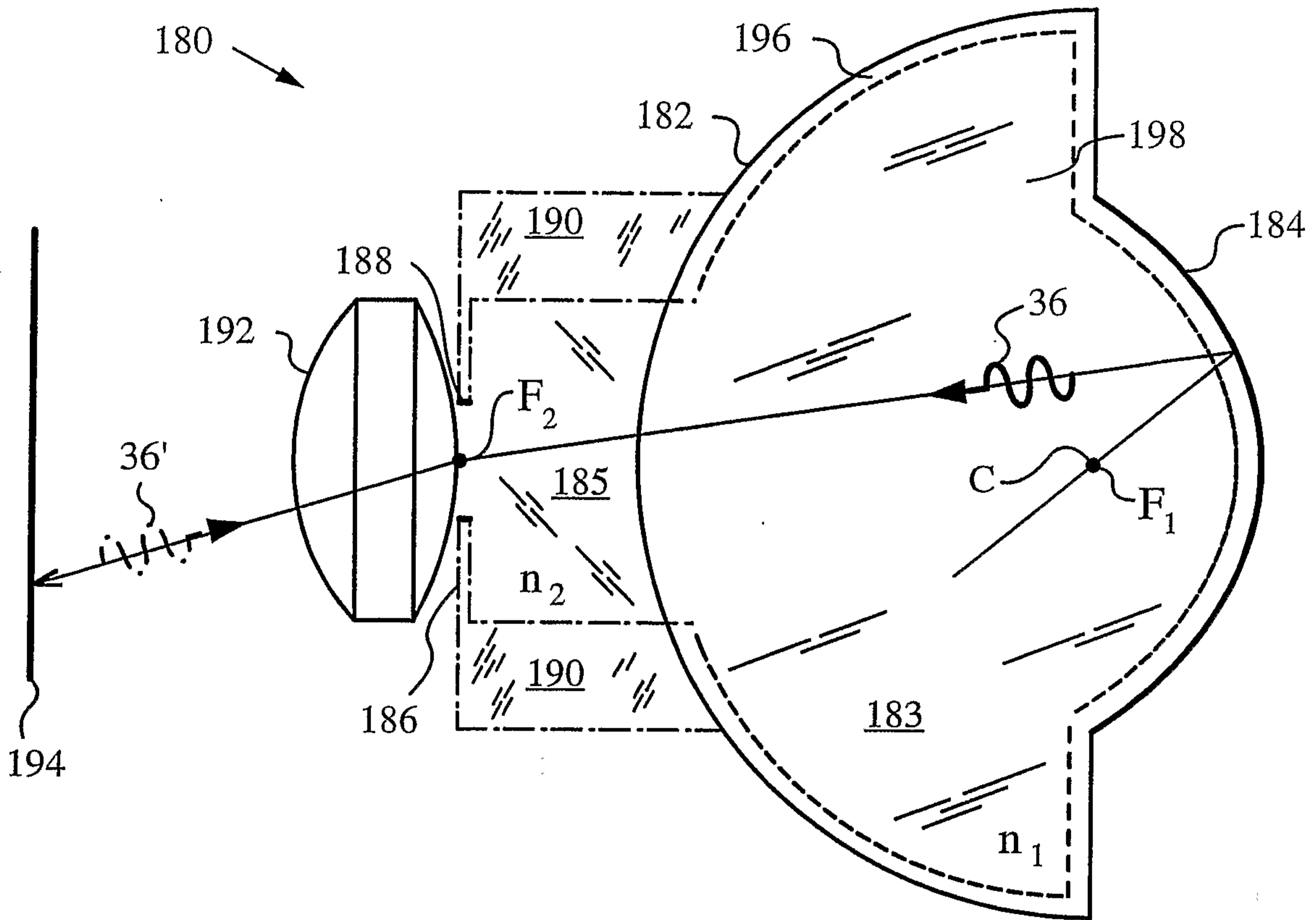

FIG. 10

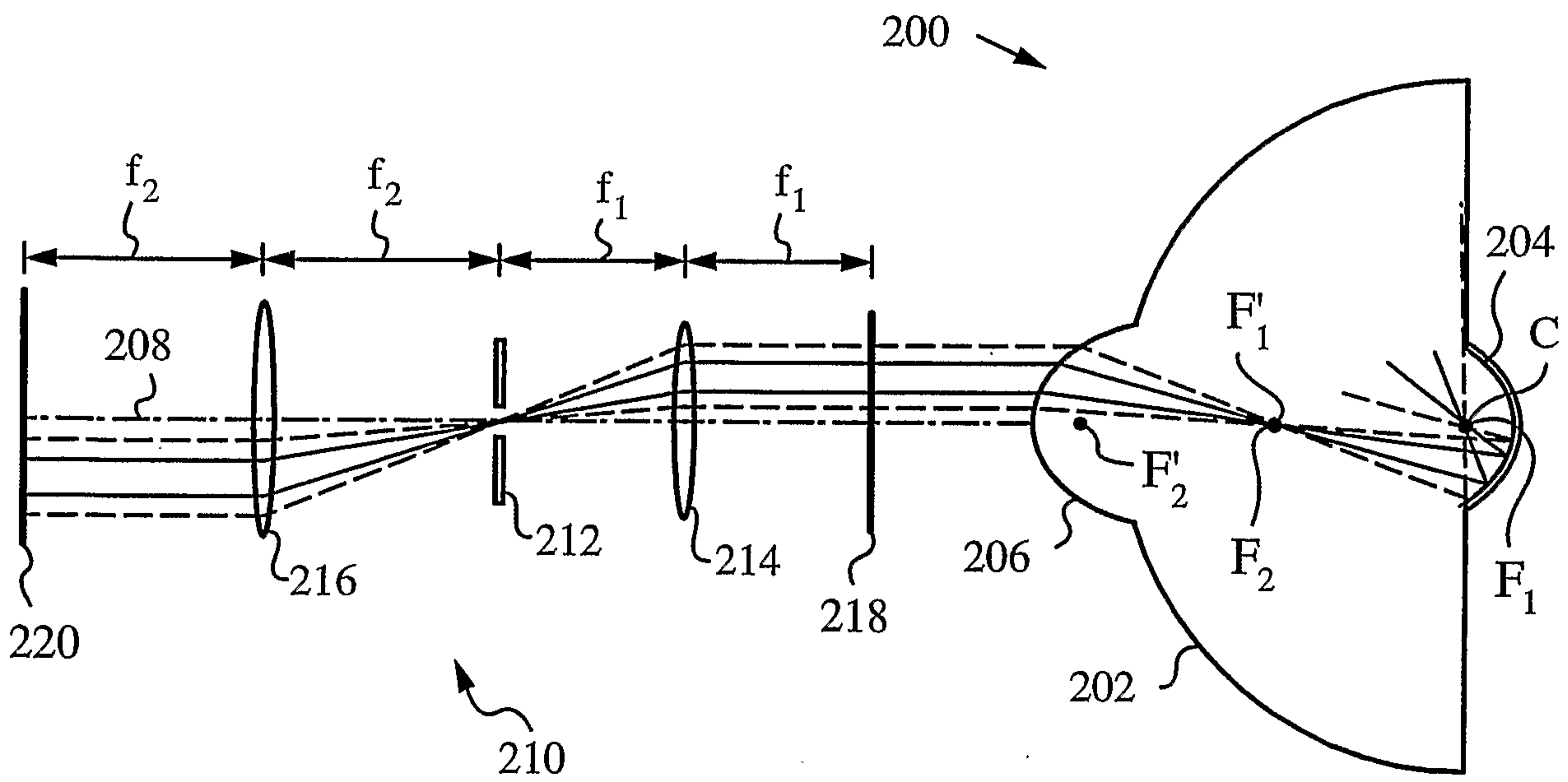

FIG. 11

