

Oct. 6, 1942.

A. GILES

2,298,050

GUIDE

Filed July 18, 1940

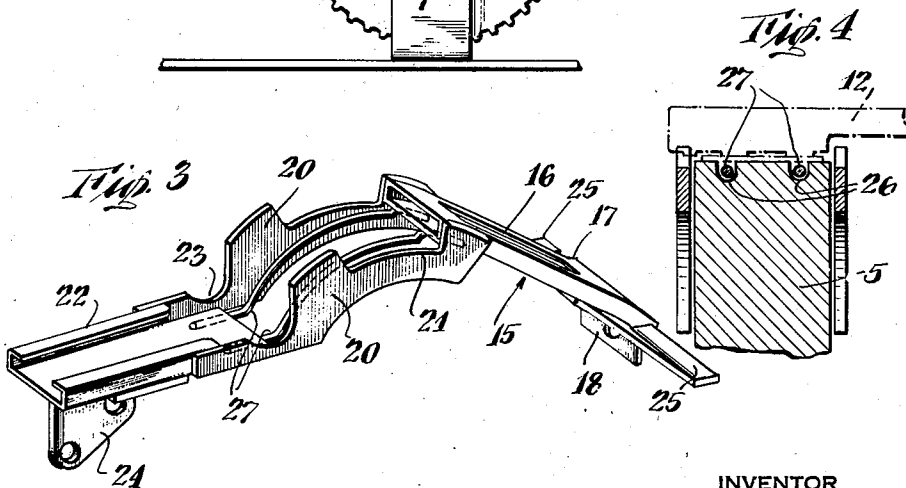
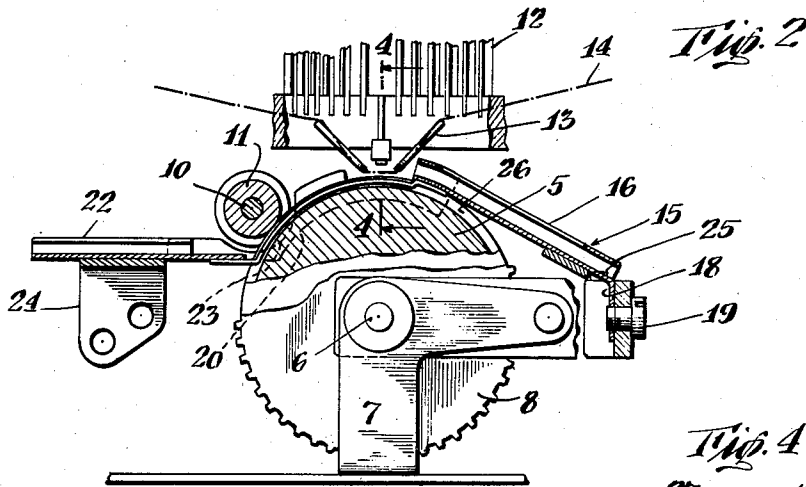
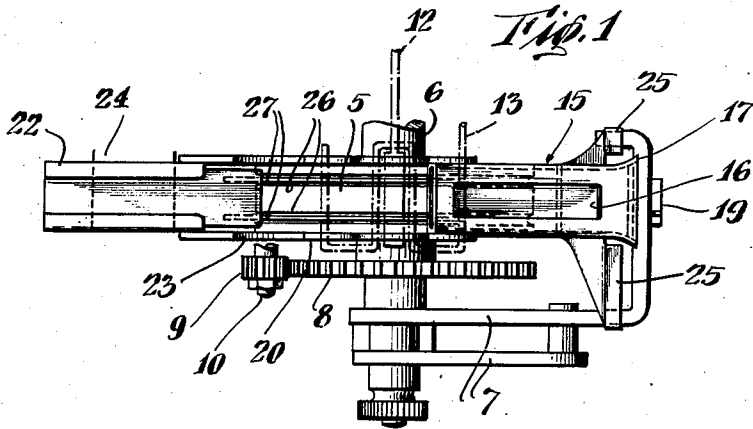

INVENTOR
Aquila Giles
BY
Duell, Kane & Sweet
ATTORNEYS

UNITED STATES PATENT OFFICE

2,298,050

GUIDE

Aquila Giles, New York, N. Y., assignor to Trans-Lux Corporation, New York, N. Y., a corporation of Delaware

Application July 18, 1940, Serial No. 346,100

5 Claims. (Cl. 197-133)

This invention relates to a functionally and structurally improved guide assembly capable of use in numerous different associations, but primarily intended to be improved in connection with imprinting machines such as tele-typewriters.

It is a well appreciated fact in connection with machines of such character, that considerable difficulty has been experienced due to the imprint receiving layer—such as a tape—adhering to the platen of the machine. This has occurred incident to a number of factors and has been especially noticeable where tapes of light gage were employed. In fact, in certain instances, the tape has become coiled around the platen a number of times before this condition has been observed and this has necessitated an interruption to the operation of the machine and in certain instances, a partial dis-assembly of the latter. Difficulty has, in fact, occurred in certain instances even with the inking ribbon of the machine in that the latter has tended to adhere to the tape. Also, in certain instances, difficulty has been experienced due to side-wise displacement of the tape.

Thus, it is an object of the invention to provide a guide structure which may readily be associated with an imprinting machine and especially a tele-typewriter and by means of which displacement of the tape or improper adhesion of the latter and/or the inking ribbon with the respect to the platen is prevented.

A further object of the invention is that of furnishing a structure of this nature and which will require no reconstruction of the machine to which it is applied and which, moreover, will not interfere in any manner with the operation of such machine.

An additional object is that of furnishing a guide assembly which will include relatively few and rugged parts which may be economically manufactured and which may be readily applied to or removed from the machine with which such assembly is intended to cooperate.

With these and other objects in mind, reference is had to the attached sheet of drawings illustrating one practical embodiment of the invention, and in which:

Fig. 1 is a fragmentary plan view of the imprinting station or portion of a tele-typewriter or similar unit and with my improved attachment in association therewith;

Fig. 2 is a fragmentary partly sectional front view of the apparatus as illustrated in Fig. 1;

Fig. 3 is a perspective view of the guide; and

Fig. 4 is a transverse sectional view taken along the lines 4-4 and in the direction of the arrows as indicated in Fig. 2.

In these views the numeral 5 indicates the platen of an indicia imprinting machine such as a tele-typewriter and which platen may be mounted by a shaft 6 supported upon a bracket 7. Secured to rotate with the platen is a gear 8, the teeth of which mesh with the teeth of a gear 9 mounted upon a shaft 10. As illustrated, especially in Fig. 2, this shaft supports a guiding or clamping roller 11, the surface of which is adapted to lie immediately adjacent the surface of the platen.

As also illustrated in these views, a bank of type bars 12 may be disposed to the rear of the platen and be movable into a position such that they will imprint upon the surface of a strip or layer of material passing over the platen. Such imprinting conveniently occurs adjacent the uppermost zone into which the platen extends and at this point, a guide bar or rod assembly 13 is provided and which serves to maintain in proper position and guide an inking ribbon 14.

The foregoing is merely illustrative of one more or less conventional type of imprinting machine. Except as hereinafter defined in certain of the combination claims, it forms no part of my present invention. Such invention might be employed in connection with numerous machines of a similar character but differing to a greater or lesser extent in structure from the assembly heretofore described. It will also be understood that in such assembly and having in mind the purposes of the illustration, there have not been shown any of the mechanisms whereby the type bars are moved, the platen is driven, shifting of the platen with reference to the type heads is effected, etc.

Referring to the guide structure, it will be observed that there is preferably employed a single metallic member, the several parts of which are fixed with respect to each other. This structure might obviously be altered in numerous respects. It includes a guide or chute 15 which may be in the nature of a sleeve and which may be formed with an aperture 16 in its upper face. The forward or entrance end of the chute is conveniently flared as at 17 and adjacent this end of the assembly a downwardly extending plate 18 may be provided and which is formed with a perforation to accommodate the shank of a bolt 19 which may extend through an opening in the bracket 7, or may otherwise suitably

secure against movement the forward end of the guide.

To the rear of the chute 15 there is provided a pair of side wall portions 20. These are preferably curved to conform generally to the curvature of the platen surface. The side walls are adapted to rest or be mounted adjacent the side faces of the platen and extend into planes beyond and below the peripheral edge of such platen. However, in line with the typing station, these side walls are notched as indicated at 21. Accordingly, the two side walls being spaced a distance greater than the width of the platen, it follows that in line with such notching their outermost edges will terminate short of the periphery of the platen. Accordingly, as the platen and type bars are shifted with respect to each other, no interference will be caused between the side walls and the type bars. This has been clearly brought out in Fig. 4.

Beyond the side walls 20, the guide is continued in the form of a delivery chute 22 which as shown, may have a solid base portion and inwardly extending flanges adjacent its upper edges; these flanges acting as a confining structure. Also, it will be observed that in order to accommodate the roller 11, the rear edges of the side walls 23 are recessed as indicated at 23. Accordingly, as the roller is shifted into and out of position, no interference will occur between it and the guide.

It will be noted that the chute 22 may be provided with an ear 24 formed with openings through which securing elements (not shown) may extend. In this manner, the rear or delivery end of the chute is supported. Finally, with reference to this structure, it will be observed that extensions 25 may form a part of, or be secured to the chute 15 and bear against adjacent bracket portions. Also, it will be observed that the platen 5 is conveniently formed with grooves 25 in its periphery and these grooves accommodate wires or rods 27 of restricted circumference which have their opposite ends supported between chutes 15 and 22. These rods as well as the grooves have been shown in a somewhat exaggerated fashion in order that the structure may be clearly visualized. In actual practice, it is preferred that these parts be of a relatively reduced size.

In employing a unit of this character, it will only be necessary to apply the same to the machine in the manner shown and supported so that the forward end of the guide is mounted by the relatively rigid bracket 7, while the rear end of the guide is similarly supported by any of a number of mounting elements. In such position, it is obvious that no interference will occur between the guide and the platen in that the guide, in effect, is supported completely free of the latter. The tape may be threaded through the chute 15 and lie in contact with the platen in the usual manner. Such disposition of the parts is assured by the roller 11 or its equivalent. The imprinted tape will be delivered through the chute 22 and, for example, beyond the casing (not shown) which encloses the entire apparatus. It is apparent that no matter what the conditions may be, the tape will not adhere to the platen and wrap around the same because the bars or wires 27 will serve as definite guides to positively expel the tape from contact with the periphery of the platen as the latter rotates. Also, it will be appreciated that due to the chutes 15 and 22 as well as the side walls 20, any sidewise displacement of the tape will be prevented.

From the foregoing, it is apparent that, among others, the objects of the invention as specifically aforementioned, are achieved. Obviously, numerous changes in construction and rearrangements of the parts might be resorted to without departing from the spirit of the invention as defined by the claims.

I claim:

1. In combination, an imprinting machine including a rotatable platen presenting an imprinting station and adapted to support a tape on its periphery adjacent said station, a guide including an elongated tape-mounting body extending generally transverse with respect to the axis of rotation of the platen, said guide moreover extending towards the imprinting station of said platen and away from such station, said body embracing a chute portion terminating short of said imprinting station, a further chute portion disposed beyond such station and side walls connecting said portions, said side walls being spaced a distance greater than the width of said platen and lying one adjacent each of the side faces of the latter and having portions extending beyond the periphery of the same whereby to prevent sidewise displacement of the tape from said platen.

2. In combination, an imprinting machine including a rotatable platen presenting an imprinting station and adapted to support a tape adjacent said station and a guide including a tape mounting body extending towards the imprinting station of said platen and away from such station, said body embracing a chute portion terminating short of said imprinting station, a further chute portion disposed beyond such station and side walls connecting said portions, said side walls being spaced a distance greater than the width of said platen and lying one adjacent each of the side faces of the latter and having portions extending beyond the periphery of the same whereby to prevent sidewise displacement of the tape from said platen, said side walls being notched in line with said imprinting station.

3. In combination, an imprinting machine including a rotatable platen presenting an imprinting station and adapted to support a tape adjacent said station and a guide including a tape mounting body extending towards the imprinting station of said platen and away from such station, said body embracing a chute portion terminating short of said imprinting station, a further chute portion disposed beyond such station and side walls connecting said portions, said side walls being spaced a distance greater than the width of said platen and lying one adjacent each of the side faces of the latter and having portions extending beyond the periphery of the same whereby to prevent sidewise displacement of the tape from said platen, a roller forming a part of said machine and cooperating with said platen and said side walls being notched in line with said roller, whereby to clear the latter.

4. In combination, an imprinting machine including a relatively narrow platen, a pair of guide members to receive a tape passing over said platen and one of said members being disposed in advance of said platen while the second of the same is disposed to the rear of such platen, means for mounting said members, said platen being formed with a pair of grooves in its periphery, wires extending between said members and curved to lie within said grooves and below the periphery of said platen and side walls extending

between said members and lying to either side of said platen and beyond said wires, said side walls having portions of their outer edges extending beyond the periphery of said platen whereby to provide a guide preventing the side-wise displacement of tape from said platen.

5. As an article of manufacture, a guide for association with an imprinting machine having a relatively narrow platen and provided with peripheral grooves in its face, said guide comprising a pair of wires curved to lie within said

grooves and extend substantially parallel to the periphery of said platen, said wires acting to eject a tape from association with the periphery of said platen, means for mounting said wires whereby said platen may rotate with respect to the same and a pair of side walls forming a part of such mounting means and arranged beyond said wires, said walls being adapted to lie to either side of said platen and to have portions extend beyond the periphery of the same.

AQUILA GILES.