

K. P. KLINGBERG.  
PLOW COLTER.  
APPLICATION FILED APR. 3, 1905.

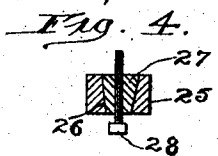
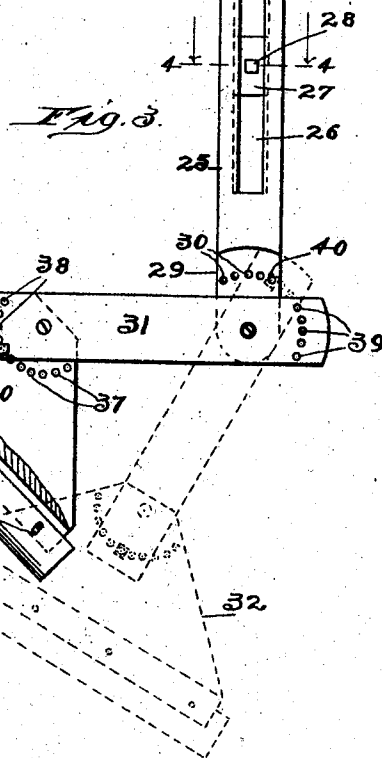
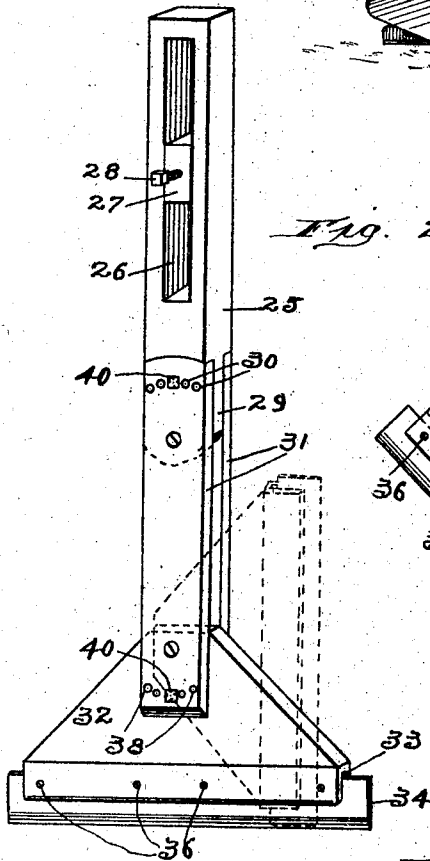
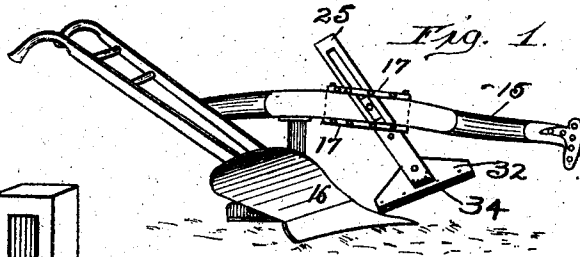

Witnesses:

Chas. E. Gorton.  
A. Gustafson.

Inventor:

Karl P. Klingberg  
BY Chas. Tillman  
ATTY.

K. P. KLINGBERG.  
PLOW COLTER.

APPLICATION FILED APR. 3, 1905.

2 SHEETS—SHEET 2.

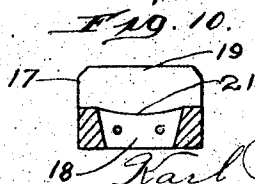
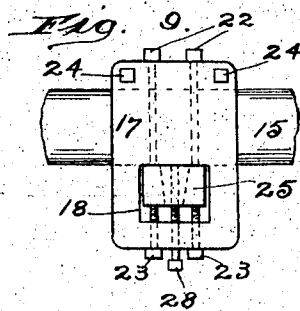
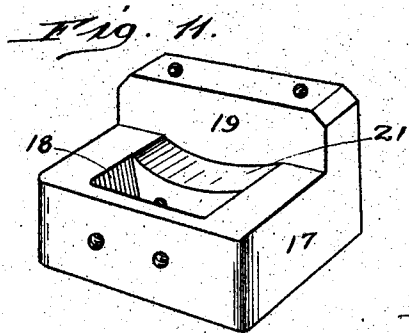
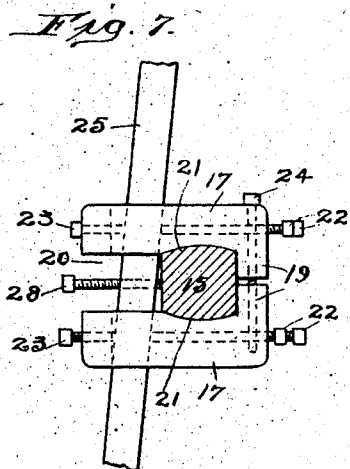
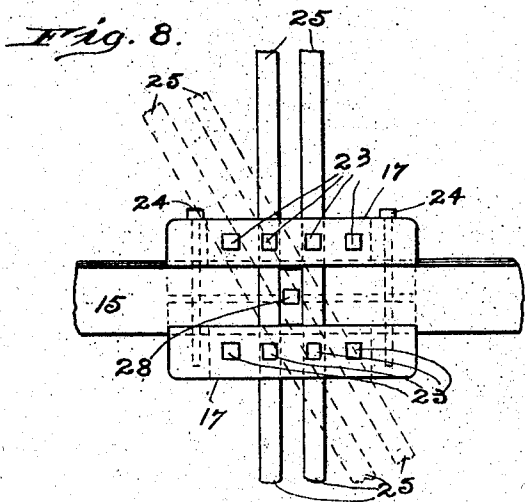
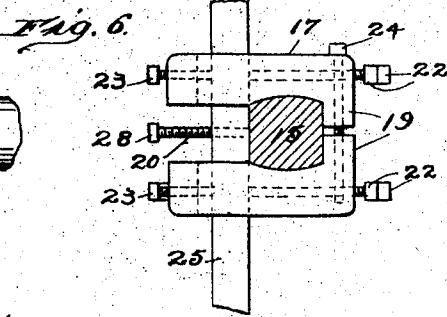
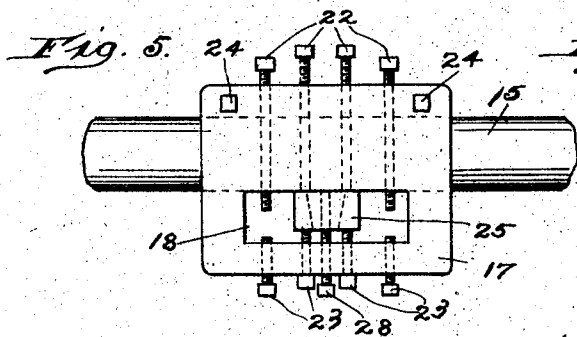

Witnesses:

Chas. C. Gorton.

A. Gustafson

Inventor:

Karl P. Klingberg.

By Chas. Pittman  
ATTY.

# UNITED STATES PATENT OFFICE.

KARL P. KLINGBERG, OF CHICAGO, ILLINOIS.

## PLOW-COLTER.

No. 796,225.

Specification of Letters Patent.

Patented Aug. 1, 1905.

Application filed April 3, 1905. Serial No. 253,431.

*To all whom it may concern:*

Be it known that I, KARL P. KLINGBERG, a subject of the King of Sweden and Norway, residing at Chicago, in the county of Cook and State of Illinois, have invented certain new and useful Improvements in Plow-Colters, of which the following is a specification.

This invention relates to improvements in colters to be attached to plows of various kinds; and it consists in certain peculiarities of the construction, novel arrangement, and operation of the various parts thereof, as will be hereinafter more fully set forth and specifically claimed.

The principal object of my invention is to provide a colter for cutting the sod, straw, stubble, roots, and briars or vines in front of the plow proper which shall be simple and inexpensive in construction, strong, durable, and effective in operation, and which shall be so made that the colter-blade may be adjusted to various angles, so as to attain the greatest degree of efficiency.

Another object of the invention is to so construct the different parts of the device that it may be readily attached to plows of different constructions or easily removed therefrom and the blade so adjusted as to present a greater or longer cutting-surface than by colters of the usual construction.

Other objects and advantages of the invention will be disclosed in the subjoined description and explanation.

In order to enable others skilled in the art to which my invention pertains to make and use the same, I will now proceed to describe it, referring to the accompanying drawings, in which—

Figure 1 is a view in side elevation of a plow, showing my improved colter applied thereto and the parts in position ready for use. Fig. 2 is a perspective view of the jointed or adjustable support for the colter-blade, showing the same by dotted lines turned to a vertical position. Fig. 3 is a view in side elevation of said support, showing by continuous lines one of the positions to which the colter-blade can be adjusted and by dotted lines another position thereof. In this view a part of the blade-holder is shown as broken to illustrate the adjustability thereon of the blade. Fig. 4 is a cross-sectional view of the support, taken on line 4 4 of Fig. 3, looking in the direction indicated by the arrows. Fig. 5 is a plan view of a portion of the plow-beam, showing the adjustable support-holder

in place thereon and as retaining the support in its vertical position. Fig. 6 is an end view thereof. Fig. 7 is a similar view showing the support deflected laterally. Fig. 8 is a view in side elevation of a portion of the plow-beam, showing the support-holder thereon and illustrating by full lines the vertical position of the support and by dotted lines one of its longitudinally-inclined positions. Fig. 9 is a plan view of a portion of the plow-beam with the support-holder thereon, showing a modification in its construction. Fig. 10 is a view, partly in section and partly in elevation, of one of the clamping members of the support-holder; and Fig. 11 is an enlarged perspective view thereof.

Like numerals of reference refer to corresponding parts throughout the different views of the drawings.

The reference-numeral 15 indicates the beam of a plow, which may be of the ordinary or any preferred construction. Mounted on this beam in front of the plow 16 is a holder for the adjustable or jointed support for the colter-blade, which holder comprises two clamping members 17, which are counterparts of one another, one of which is adapted to rest on the top of the beam 15 and the other on the bottom thereof. As is clearly shown in Figs. 5 to 10, inclusive, of the drawings, each of the clamping members 17 is provided near one of its sides with an opening 18 for the reception and operation of the adjustable support for the colter-blade and is provided on its other side with an extension 19, thus forming a recess 20 for the reception of the plow-beam 15, the inner portions of said recesses being curved, as at 21, to correspond with the curved surfaces of the beam. It will be noted by reference to Figs. 6, 7, and 11 that the curved parts 21 of the clamping members are located between the extensions 19 thereon and the inner edge of the openings 18 in said members.

Each of the members 17 is provided with a number of screw-bolts 22 and 23, the bolts 22 being located on one side and the bolts 23 on the other side of each of said members. These bolts are arranged on the upper member so as to lie over the plow-beams and on the lower member under the same. Vertically connecting the members 17 near each of their corners on one side of the beam 15 is a screw-bolt 24, which bolts are used for drawing the clamping members together. As shown in Figs. 6, 7, and 8 of the drawings, the recesses 20 ex-

tend through one side of the member 17, thus leaving an opening therein.

The adjustable or jointed support for the colter-blade comprises a bar 25, having a longitudinal slot 26 therein, which slot is flared inwardly when the support is on the plow-beams and has located therein a beveled block 27, which carries a screw-bolt 28, which block and bolt are used for the purpose to be presently explained. The lower portion of the bar 25 is reduced to provide a tongue 29, which is formed with a number of openings 30, preferably arranged in a curved line. Pivotaly secured on each side of the tongue 29 is a bar 31, which extend downwardly in parallelism with one another and have pivoted between their lower portions the colter-blade holder 32, which has its lower edge formed with a groove 33 to receive the colter-blade 34, which blade is provided with a series of transverse slots 35 to receive screws 36 in the lower portion of the blade-holder 32, which slots and screws will permit of the inward and outward adjustment of said blade. The upper portion of the holder 32 is provided with a series of openings 37, which are arranged in a circular line to register with a series of openings 38, with which each of the bars 31 is formed in its lower portion. The upper ends of the bars 31 are also provided with a series of openings 39 to register with the openings 30 in the tongue 29 of the support.

In Figs. 9 to 11, inclusive, of the drawings is shown a modification in the construction of the holder for the colter-blade support, which consists in omitting from each of the members 17 thereof two of the screw-bolts on each side of said members and also in shortening the opening 18 for the reception and operation of said support.

From the foregoing and by reference to the drawings it will be readily understood and clearly seen that by placing the members 17 of the support-holder on the top and bottom of the plow-beam at a suitable point thereon they may be firmly held in position by screwing up the bolts 24, which unite them on one side of the plow-beam. When thus secured in place, the bar 25 of the support may be inserted through the openings 18 in the members of the holder, and the same may be held in the position shown by full lines in Fig. 1 or by dotted lines in Fig. 2 of the drawings by means of two of the bolts 23 on one side of each of the members of the holder. To further secure the bar 25 in place, two of the screws 22 on the opposite side of each of the members of the holder may be screwed up against said bar. As a further securing means the block 27, carrying the screw 28, may be employed, for it is apparent that by turning said screw in the proper direction the block 27 will be wedged in the slot 26 and

force the bar 25 outwardly. When the support is held in the inclined position, as above described, it is apparent that the blade-holder 32 may be turned to any desired angle on the bars 31 and there fixed by means of a pin 40, inserted in the openings 37 and 38 of the holder and bars, respectively. By placing the support 25 in a vertical position, as shown in Figs. 6 and 8, it is evident that the inner screws 23 on one side of each of the members and the inner screws 22 on the other side of each of the members 17 will be employed to clamp the bar 25 of the support. When thus vertically held, it is apparent that a lateral inclination may be given to the support, as shown in Fig. 7 of the drawings. In any position of the bar 25 the bars 31 and blade-holder 32 may be adjusted to any desired angle by turning said parts on their pivots, when they may be fastened by means of the securing-pins 40, located in the openings in the respective parts therefor. The blade 24 may be adjusted in its holder 32 by simply loosening the screws 36, which are located in the slots 35 in said blade, after which it may be moved inwardly or outwardly, when the screws 36 may again be tightened, so as to hold it in the desired position.

Having thus fully described my invention, what I claim as new, and desire to secure by Letters Patent, is—

1. In a plow-colter, the combination with an apertured adjustable holder for the colter-blade support, of a pivotaly-jointed support for said blade located in said holder, means on the holder to adjust the support vertically as well as longitudinally of the plow-beam, means to adjust the said support in a laterally-inclined position on the plow-beam, a holder for the blade adjustably mounted on one of the joints of the support, and a blade adjustable on its holder, substantially as described.

2. In a plow-colter, the combination with a support-holder comprising an upper and lower clamping member adjustably connected and each having a recess to receive the plow-beam and a vertical opening, of a pivotaly-jointed support for the blade located in the vertical openings of the support-holder, a holder for the blade adjustably mounted on one of the joints of the support, a blade adjustable on its holder, and a series of screw-bolts transversely located in each of the members of the support-holder whereby the support may be adjusted vertically as well as longitudinally of the plow-beam and said support may be adjusted to a laterally-inclined position, substantially as described.

KARL P. KLINGBERG.

Witnesses:

A. GUSTAFSON,  
J. WILLIAMS.