

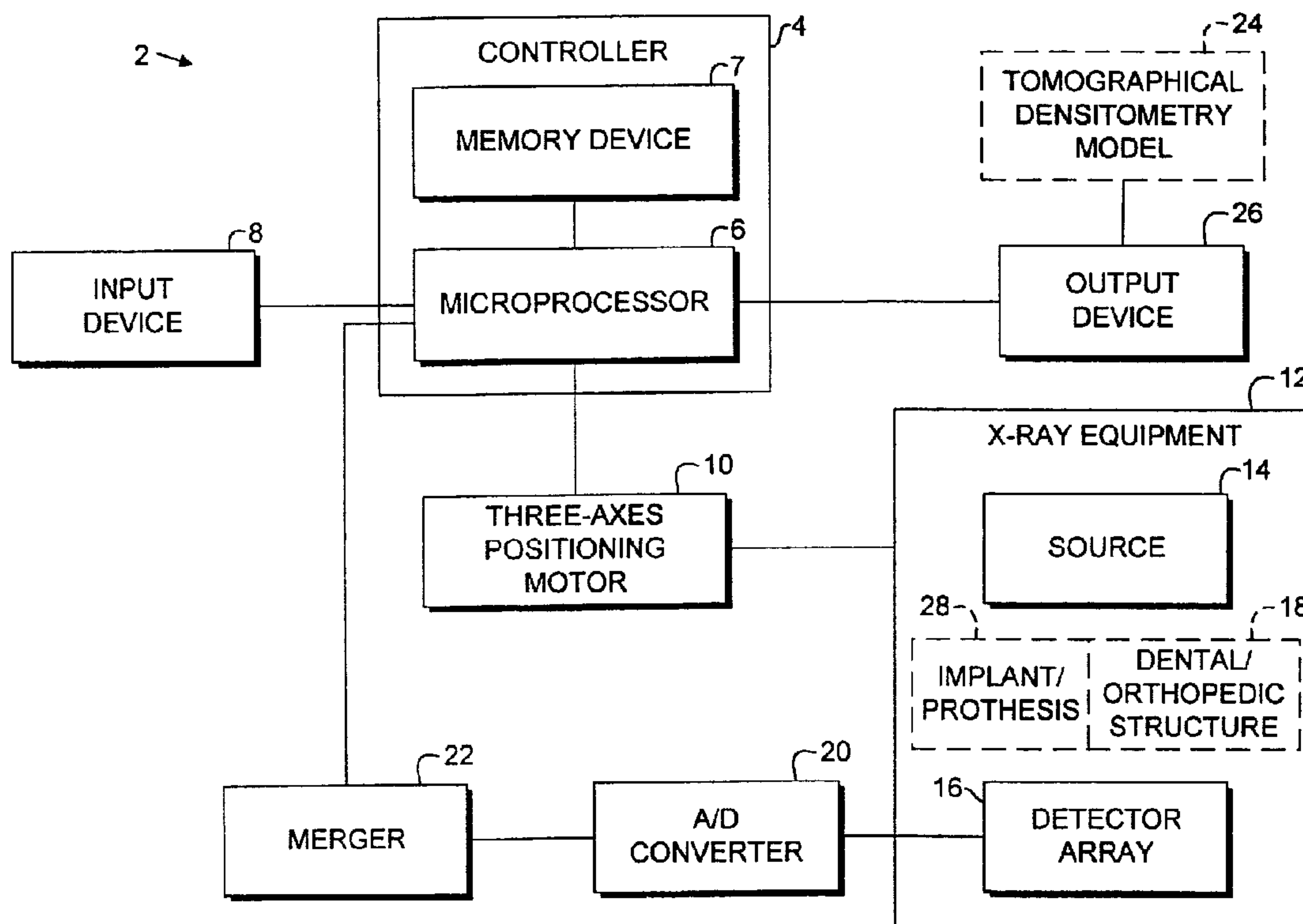

(86) Date de dépôt PCT/PCT Filing Date: 2000/12/01
 (87) Date publication PCT/PCT Publication Date: 2001/06/07
 (45) Date de délivrance/Issue Date: 2008/11/18
 (85) Entrée phase nationale/National Entry: 2002/05/07
 (86) N° demande PCT/PCT Application No.: US 2000/032905
 (87) N° publication PCT/PCT Publication No.: 2001/039667
 (30) Priorité/Priority: 1999/12/01 (US09/452,348)

(51) Cl.Int./Int.Cl. *A61B 6/14* (2006.01),
H05G 1/64 (2006.01), *A61B 6/03* (2006.01)
 (72) Inventeur/Inventor:
MASSIE, RONALD E., US
 (73) Propriétaire/Owner:
MASSIE, RONALD E., US
 (74) Agent: MOFFAT & CO.

(54) Titre : SYSTEME ET METHODE DE MODELISATION EN DENSITOMETRIE DENTAIRE ET ORTHOPEDIQUE
 (54) Title: DENTAL AND ORTHOPEDIC DENSITOMETRY MODELING SYSTEM AND METHOD



(57) Abrégé/Abstract:

A dental and orthopedic densitometry modeling system includes a controller (4) with a microprocessor (6) and a memory device (7) connected to the microprocessor (6). An input device (8) is also connected to the microprocessor (6) for inputting diagnostic procedure parameters and patient information. X-ray equipment including an X-ray source (14) and an X-ray detector array (16) are connected to a positioning motor (10) for movement relative to a patient's dental or orthopedic structure (18) in response to signals from the microprocessor (6). The output consists of a tomographical densitometry model. A dental/orthopedic densitometry modeling method involves moving the X-ray equipment across a predetermined scan path, emitting dual-energy X-ray beams, and outputting an image color-coded to correspond to a patient's dental or orthopedic density.

ABSTRACT

A dental and orthopedic densitometry modeling system includes a controller (4) with a microprocessor (6) and a memory device (7) connected to the microprocessor (6). An input device (8) is also connected to the microprocessor (6) for inputting diagnostic procedure parameters and patient information. X-ray equipment including an X-ray source (14) and an X-ray detector array (16) are connected to a positioning motor (10) for movement relative to a patient's dental or orthopedic structure (18) in response to signals from the microprocessor (6). The output consists of a tomographical densitometry model. A dental/orthopedic densitometry modeling method involves moving the X-ray equipment across a predetermined scan path, emitting dual-energy X-ray beams, and outputting an image color-coded to correspond to a patient's dental or orthopedic density.

PCT/US 00/32905
IPEA/US 30 JUN 2001

1 **DENTAL AND ORTHOPEDIC DENSITOMETRY MODELING**

2 **SYSTEM AND METHOD**

3 **Background of the Invention**

4 1. **Field of the Invention**

5 The present invention relates generally to dental and orthopedic diagnosis and
6 treatment, and in particular to a densitometry modeling system and method.

7
8 2. **Description of the Related Art**

9 The field of dental diagnostics is generally concerned with locating pathologies
10 in the dental structure, i.e. the teeth and surrounding tissue and bone. Three of the
11 most common pathologies are: 1) caries associated with decay; 2) fractures; and 3)
12 apical abscesses. The system and method of the present invention are primarily, but
13 not exclusively, concerned with detecting these pathologies and with orthopedics.

14 Early detection of dental pathologies is very important in minimizing damage.
15 Conventional diagnosis procedures are generally performed using dental X-rays (both
16 fixed beam and scanning beam), explorers, and other conventional equipment.

17 Incipient caries, particularly those located beneath the enamel surface, often go
18 undetected with conventional equipment. When such caries are finally found,

1 incipient caries are located almost entirely within the enamel layer of the teeth. They
2 are sometimes referred to as "smooth surface" caries and are particularly difficult to
3 locate using conventional diagnostic equipment and procedures. By the time such
4 incipient caries are located, the extent of the damage is often 17% to 23% greater than
5 it would appear to be on a conventional X-ray negative.

6 Dental fractures can result from bruxism (teeth grinding), trauma, etc. Dental
7 structure which is weakened by various causes, such as decalcification, is particularly
8 susceptible to fractures. Fractures can assume various configurations, including craze
9 line patterns. Fracture patterns and configurations can be particularly difficult to locate
10 using conventional X-ray equipment and procedures. For example, fractures which are
11 generally parallel to the X-ray beam are often undetectable on an X-ray negative.
12 Undetected, and hence untreated, fractures can provide direct paths through the
13 enamel layer of the teeth whereby bacteria can invade the dentin and pulp layers.
14 Pathologies in the dentin and pulp layers are often associated with considerable pain
15 and tooth loss.

16 Apical abscesses comprise yet another dental condition which can be difficult to
17 diagnose with conventional equipment, particularly in the early stages. Advanced
18 apical abscesses can cause considerable pain because they involve the neurovascular
19 bundles located in the root canals. Early detection of apical abscesses can lead to
20 appropriate, early-stage treatment, thus avoiding advanced disease processes with
21 resultant pain, swelling, and/or space involvement which left untreated could ultimately
22 result in death.

Tomography or sectional radiography techniques using scanning X-ray beams have previously been employed for dental applications. For example, U.S. Pat. No. 4,188,537; U.S. Pat. No. 4,259,583; U.S. Pat. No. 4,823,369; U.S. Pat. No. 4,856,038; and U.S. Pat. No. 5,214,686 all relate to dental X-ray diagnosis utilizing scanning techniques.

5 In the medical field, densitometry procedures are used for measuring bone morphology density (BMD) by utilizing scanning X-ray beam techniques. Examples are shown in U.S. Pat. No. 5,533,080; U.S. Pat. No. 5,838,765; and U.S. Pat. No. Re. 36,162. Medical applications of densitometry include the diagnosis and treatment of such bone diseases as osteoporosis.

10 The availability of relatively fast computers with large memories at reasonable costs has led to the digitalization of X-ray images for mapping BMD models in various formats. For example, BMD images use color to identify varying densities. Digital BMD patient models are also used for comparison purposes with standard models and with patients' own prior BMD histories. Age correction factors can be applied to patients' models for diagnosing and monitoring the onset and progress of such medical conditions as osteoporosis and the like. The present invention utilizes such densitometry modeling and mapping techniques for dental applications.

15 In addition to pathology detection and diagnosis, the present invention has applications in monitoring osseointegration. Osseointegration occurs at the interface between bone structures and prostheses, such as implants and replacement joints. For 20 example, dental implants osseointegrate with patients' dental structure. The

1 application of tomographical densitometry techniques to osseointegration monitoring
2 can provide the dental or medical practitioner with important information in evaluating
3 the effectiveness of implant procedures.

4 Heretofore there has not been available a system or method for applying the
5 technology of densitometry to dental and medical applications such as the detection of
6 caries and decalcification and the monitoring of osseointegration in connection with
7 dental and medical prostheses.

8

9

Summary of the Invention

10 In the practice of the present invention, a dental and orthopedic densitometry
11 modeling system utilizes a controller with a microprocessor and memory. An input
12 device inputs data to the microprocessor for controlling the operation of the modeling
13 system and for providing a database including densitometry parameters for comparison
14 with a patient's densitometry model. The controller controls the operation of X-ray
15 equipment, which is adapted for scanning patients' dental and orthopedic structures
16 along preprogrammed scan paths. The X-ray output is processed by the
17 microprocessor for creating a densitometry model, which can be output in various
18 formats. In the practice of the method of the present invention, a patient and the X-ray
19 equipment are positioned relative to each other. A controller is preprogrammed with a
20 scan path and with data corresponding to the patient. The X-ray equipment emits and
21 detects X-ray beams at first and second energy levels to provide densitometry output.
22 The densitometry output is digitized and merged to provide a tomographic model,

which can be compared to predetermined parameters unique to the patient. The model can be output in various formats, including a visual image color-coded to depict varying dental and orthopaedic structure densities.

In a broad aspect, the present invention relates a system for tomographically
5 modelling dental and orthopaedic structure densitometry, including: a controller with a
microprocessor and a memory device connected to the microprocessor; an input device
connected to the microprocessor; X-ray equipment including an X-ray source and a
detector array; conversion means comprising an analog-to-digital converter connected to
said detector array and to said microprocessor and being arranged to convert a signal from
10 said detector array; an output device connected to said microprocessor and adapted for
receiving a tomographical densitometry model from said microprocessor; and a merger
device connected to said converter and to said microprocessor; said tomographical
modeling system including: a positioning motor adapted for positioning said X-ray
equipment with respect to three axes of movement; said X-ray equipment comprising a
15 dual energy level, restricted beam device; means for storing pre-existing, graphical dental
or orthopaedic densitometry models comprising a patient's previous graphical
densitometry models and baseline standardized graphical densitometry models; a
preprogrammed scan path for said X-ray equipment, said scan path being programmed into
said microprocessor and said scan path including movement of said X-ray equipment in
20 three axes; said microprocessor receiving digital data corresponding to a graphical
densitometry dental or orthopedic model and converting said densitometry model to a
visual image computer means for digitally comparing pre-existing and current
tomographical densitometry models, said output device displaying a visual representation
of said comparison of said pre-existing and current graphical densitometry models.

In another broad aspect, the present invention relates to a method for topographically modelling dental and orthopaedic structure densitometry including the steps of providing: a controller with a microprocessor and a memory device connected to the microprocessor; an input device connected to the microprocessor; X-ray equipment including an X-ray source and a detector array; an analog-to-digital converter connected to said detector array and to said microprocessor for converting a signal from said detector array; an output device connected to said microprocessor and adapted for receiving a tomographical densitometry model from said microprocessor; which method further includes the steps of: inputting patient diagnostic parameters with said input device; inputting baseline diagnostic parameters with said input device; storing said diagnostic parameters in said memory device; positioning said X-ray equipment and a patient's dental or orthopaedic structure relative to each other with said patient's dental or orthopaedic structure between said source and said detector array; emitting an X-ray beam from said source through said dental or orthopaedic structure and to said detector array; outputting a signal from said detector array to said microprocessor and storing said signal from said detector array in said microprocessor; forming with said microprocessor a current tomographical densitometry model of said dental or orthopaedic structure; converting said current tomographical densitometry model to a visual image; outputting said current tomographical densitometry model to said output device; emitting, detecting, digitizing and storing signals corresponding to first and second energy levels from said X-ray source; inputting to said controller a predetermined scan path including movement with respect to three axes for said X-ray equipment; traversing said X-ray equipment along said scan path; providing a positioning motor connected to said microprocessor and to said X-ray equipment for moving same through three axes of movement along said scan path;

inputting to said microprocessor a patient's pre-existing tomographical densitometry model; digitally comparing said patient's current densitometry model to said pre-existing tomographical densitometry model ; and visually displaying with said output device a visual representation of said comparison of said patient's pre-existing and current
5 densitometry models.

Principle Objects and Advantages of the Invention

The principle objects and advantages of the present invention include: providing a dental and orthopaedic diagnostic application for densitometry; providing such an
10 application which includes a method for modelling dental and orthopaedic structure using densitometry; providing such a method which includes dual-energy, X-ray emission and detection; providing such a method which includes providing a color-coded output model showing dental density; providing such a method which detects incipient caries; providing such a method which is adapted for detecting decalcification beneath the surface of the
15 dental enamel layer; providing such a method which employs scanning X-ray techniques; providing such a method which utilizes commercially available tomography equipment; providing such a method which detects dental fractures; providing such a method which detect dental apical abscesses; providing such a method which detects dental pathologies at the micron level; providing such a method which facilitates the monitoring of
20 decalcification in dental structures for determining appropriate treatment; providing such a method which is adaptable for monitoring osseointegration; providing such a method which can be practiced with relatively minor changes to existing densitometry equipment; and providing such a

25

1 method which is economical in operation and particularly well adapted for the
2 proposed usage thereof.

3 Other objects and advantages of this invention will become apparent from the
4 following description taken in conjunction with the accompanying drawings wherein
5 are set forth, by way of illustration and example, certain embodiments of this invention.

6 The drawings constitute a part of this specification and include exemplary
7 embodiments of the present invention and illustrate various objects and features
8 thereof.

9

10

Brief Description of the Drawings

11

12

Fig. 1 is a schematic, block diagram of a dental and orthopedic densitometry
modeling system embodying the present invention.

13

14

Fig. 2 is a flowchart of a dental and orthopedic densitometry modeling method
embodying the present invention.

15

16

Detailed Description of the Preferred Embodiments

17

I. Introduction and Environment

18

19

20

21

22

As required, detailed embodiments of the present invention are disclosed
herein; however, it is to be understood that the disclosed embodiments are merely
exemplary of the invention, which may be embodied in various forms. Therefore,
specific structural and functional details disclosed herein are not to be interpreted as
limiting, but merely as a basis for the claims and as a representative basis for teaching

1 one skilled in the art to variously employ the present invention in virtually any
2 appropriately detailed structure.

3 **II. Dental Densitometry Modeling System 2**

4 Referring to the drawings in more detail, the reference numeral 2 generally
5 designates a dental and orthopedic densitometry modeling system embodying the
6 present invention. The system 2 includes a controller 4 with a microprocessor 6
7 connected to a digital memory device 7. The hardware components of the controller
8 4, i.e. the microprocessor 6 and the memory device 7, can comprise any of a number of
9 suitable hardware devices which are commercially available and are suitable for this
10 application. In addition to various programable logic devices (PLDs) and special-
11 purpose microprocessors, general purpose, commercially available personal computers
12 can be utilized in the controller 4. The controller 4 can be programmed in any suitable
13 manner utilizing any of a variety of commercially available programming languages and
14 software development systems.

15 The microprocessor 6 is adapted to receive input from one or more input
16 devices 8, such as a keyboard, a pointing device (e.g., a mouse), a communications
17 link, or another computer. Without limitation on the generality of useful data which
18 can be input via the input device(s) 8, such data can include: 1) a patient's dental and
19 orthopedic records, including previous tomographical densitometry models; 2) baseline
20 tomographical densitometry models, which can be adjusted to accommodate for such
21 factors as age, gender, size, weight, etc.; and 3) a preprogrammed scan path for the X-
22 ray equipment.

PCT/US 00/32905
TPEA/US 30 JUN 2001

1 The microprocessor 6 controls a positioning motor 10 which is operably
2 connected to X-ray equipment 12 and is adapted for moving same through three axes
3 of movement. Examples of X-ray equipment adaptable for use with the present
4 invention are disclosed in U.S. Patents No. 5,533,080; No. 5,838,765; and No. Re.
5 36,162. The X-ray equipment 12 includes an X-ray beam source 14 and a detector
6 array 16. The X-ray beam can suitably collimated to assume any suitable
7 configuration, such as fan, pencil, cone, etc. With the scanning technique disclosed, a
8 restricted (i.e. collimated) beam is preferred. The source and the detector array 14, 16
9 are adapted for positioning on either side of a patient's dental/orthopaedic structure
10 18.

11 Analog signals from the detector array 16 are output to an analog-to-digital
12 (A/D) convertor 20, from which digitized signals are transmitted to a merger device 22
13 for merging into formats suitable for processing and analyzing by the microprocessor
14 6. The microprocessor 6, using data from the merger device 22, creates a
15 tomographical densitometry model 24 which is transmitted to an output device or
16 devices 26. Without limitation on the generality of useful output devices 26, it can
17 comprise a monitor, a display, a printer, a communications link, and/or another
18 computer. For example, a color printer can be utilized to provide a color-coded
19 graphical representation of the tomographical densitometry model 24. The color
20 coding can correspond to densities, thus identifying potential problem areas where
21 decalcification has occurred and resulted in lower density. The tomographical
22 densitometry model 24 can also be useful for monitoring osseointegration, since the

1 density of the dental/orthopedic structure 18 (tissue and bone) in the vicinity of an
2 implant 28 or other prostheses can provide an important diagnostic tool for the use of
3 the dental or medical practitioner in assessing the effectiveness of an implant or
4 prosthetic procedure. The tomographical densitometry model 24 is also entered into
5 the computer's memory device 7.

6

7 **III. Dental and Orthopedic Densitometry Modeling Method**

8 Fig. 2 is a flow chart of a dental and orthopedic densitometry method
9 embodying the present invention. The method steps include positioning a patient and
10 positioning the X-ray equipment relative to the patient, i.e. with the patient's
11 dental/orthopedic structure to be examined located between the X-ray source 14 and
12 the detector array 16.

13 Diagnostic parameters are input to the system and can comprise, for example,
14 the patient's prior tomographical densitometry models and standardized models. The
15 tomographical densitometry models can be corrected and/or adjusted to account for
16 patients' age, gender, physical characteristics, etc. The input diagnostic parameters
17 can be stored in the computer's memory device. A scan path for the X-ray equipment
18 is preprogrammed in the computer.

19 The scanning procedure is commenced by collimating a first energy band beam,
20 detecting emissions from same with a detector array, and converting the analog output
21 of the detector array to a digital signal. The digital signal is output for storage in the
22 computer. The steps of collimating the energy band beam and detecting, digitizing and

1 storing same are repeated for a second energy band beam. The Bisek et al. U.S. Patent
2 No. Re. 36,362 discloses the use of dual-energy X-ray beams in medical densitometry
3 applications. As discussed therein, dual-energy densitometry can result in a more
4 accurate patient model.

5 The X-ray equipment then traverses the preprogrammed scan path and the
6 first/second energy band steps are repeated until the scanning procedure is complete.
7 The digitized detector array output is merged and compared to the diagnostic
8 parameters which are stored in the computer's memory. The dental/orthopedic
9 densitometry is tomographically modeled and output, for example to a monitor or
10 printer for converting the model to a visual image. The visual image is output in a
11 visible form for use by dental and medical practitioners.

THE EMBODIMENTS OF THE INVENTION IN WHICH AN EXCLUSIVE PROPERTY OR PRIVILEGE IS CLAIMED ARE DEFINED AS FOLLOWS:

1. A system for tomographically modelling dental and orthopaedic structure densitometry, including: a controller (4) with a microprocessor (6) and a memory device (7) connected to the microprocessor (6); an input device connected to the microprocessor (6); X-ray equipment (12) including an X-ray source (14) and a detector array (16); conversion means (20) comprising an analog-to-digital (A-D) converter (20) connected to said detector array (16) and to said microprocessor (6) and being arranged to convert a signal from said detector array (16); an output device (26) connected to said microprocessor (6) and adapted for receiving a tomographical densitometry model from said microprocessor (6); and a merger device (22) connected to said converter (20) and to said microprocessor (6); said tomographical modeling system including:

a positioning motor (10) adapted for positioning said X-ray equipment (12) with respect to three axes of movement;

said X-ray equipment (12) comprising a dual energy level, restricted beam device (14);

means (7) for storing pre-existing, graphical dental or orthopaedic densitometry models comprising a patient's previous graphical densitometry models and baseline standardized graphical densitometry models;

a preprogrammed scan path for said X-ray equipment (12), said scan path being programmed into said microprocessor (6) and said scan path including movement of said X-ray equipment in three axes;

said microprocessor (6) receiving digital data corresponding to a graphical densitometry dental or orthopedic model and converting said densitometry model to a visual image

computer means (6) for digitally comparing pre-existing and current tomographical densitometry models, said output device (26) displaying a visual representation of said comparison of said pre-existing and current graphical densitometry models.

2. The system according to claim 1 wherein said output device includes a colour monitor (26) adapted to receive said tomographical densitometry model output colour-coded to represent densitometry.

3. The system according to claim 1 wherein said output device includes a colour printer (26) adapted to print images colour-coded to correspond to the densitometry of said model.

4. A method for topographically modelling dental and orthopaedic structure densitometry including the steps of providing: a controller (7) with a microprocessor (6) and a memory device (7) connected to the microprocessor (6); an input device (8) connected to the microprocessor (6); X-ray equipment (12) including an X-ray source (14) and a detector array (16); an analog-to-digital (A-D) converter (20) connected to said detector array (16) and to said microprocessor (6) for converting a signal from said detector array (16); an output device (26) connected to said microprocessor (6) and adapted for receiving a tomographical densitometry model from said microprocessor (6); which method further includes the steps of:

inputting patient diagnostic parameters with said input device (8);

inputting baseline diagnostic parameters with said input device (8);

storing said diagnostic parameters in said memory device (7);

positioning said X-ray equipment (12) and a patient's dental or orthopaedic structure (18) relative to each other with said patient's dental or orthopaedic structure (18) between said source (14) and said detector array (16);

emitting an X-ray beam from said source (14) through said dental or orthopaedic structure (18) and to said detector array (16);

outputting a signal from said detector array (16) to said microprocessor (6) and storing said signal from said detector array (16) in said microprocessor;

forming with said microprocessor (6) a current tomographical densitometry model of said dental or orthopaedic structure (18);

converting said current tomographical densitometry model to a visual image;

outputting said current tomographical densitometry model to said output device (26);

emitting, detecting, digitizing and storing signals corresponding to first and second energy levels from said X-ray source (14);

inputting to said controller (4) a predetermined scan path including movement with respect to three axes for said X-ray equipment (12);

traversing said X-ray equipment (12) along said scan path;

providing a positioning motor (10) connected to said microprocessor (6) and to said X-ray equipment (12) for moving same through three axes of movement along said scan path;

inputting to said microprocessor (6) a patient's pre-existing tomographical densitometry model;

digitally comparing said patient's current densitometry model to said pre-existing tomographical densitometry model ; and

visually displaying with said output device (26) a visual representation of said comparison of said patient's pre-existing and current densitometry models.

5. The method according to claim 4, which includes the additional step of detecting incipient caries with said tomographical densitometry model.

6. The method according to claim 4, which includes the additional step of detecting dental fractures with said tomographical densitometry model.

7. The method according to claim 4, which includes the additional step of detecting apical abscesses with said tomographical densitometry model.

8. The method according to claim 4, which includes the additional step of analysing the extent of osseointegration of a dental or orthopaedic prosthesis with respect

to said patient's dental or orthopaedic structure with said tomographical densitometry model.

9. The method according to claim 4, which includes the additional steps of:
 - a) providing a colour output device (26) connected to said microprocessor (6); and
 - b) colour coding said densitometry model in colours corresponding to the patient's dental or orthopaedic structure density and outputting said densitometry model to said output device (26).

10. The method according to claim 4, which includes the additional steps of:
 - repeating said microprocessor input, detector array output, x-ray equipment positioning and detector array output signal storing steps;
 - merging said stored detector array output signals to form a present tomographical densitometry model of said dental or orthopaedic structure (18);
 - comparing said present densitometry model with said pre-existing densitometry model;
 - adjusting said present densitometry model to account for patient parameters including age and gender;
 - colour coding said present tomographical densitometry model with colours corresponding to dental or orthopaedic structure (18) density; and
 - outputting said colour-coded model to said output device (26).

1/2

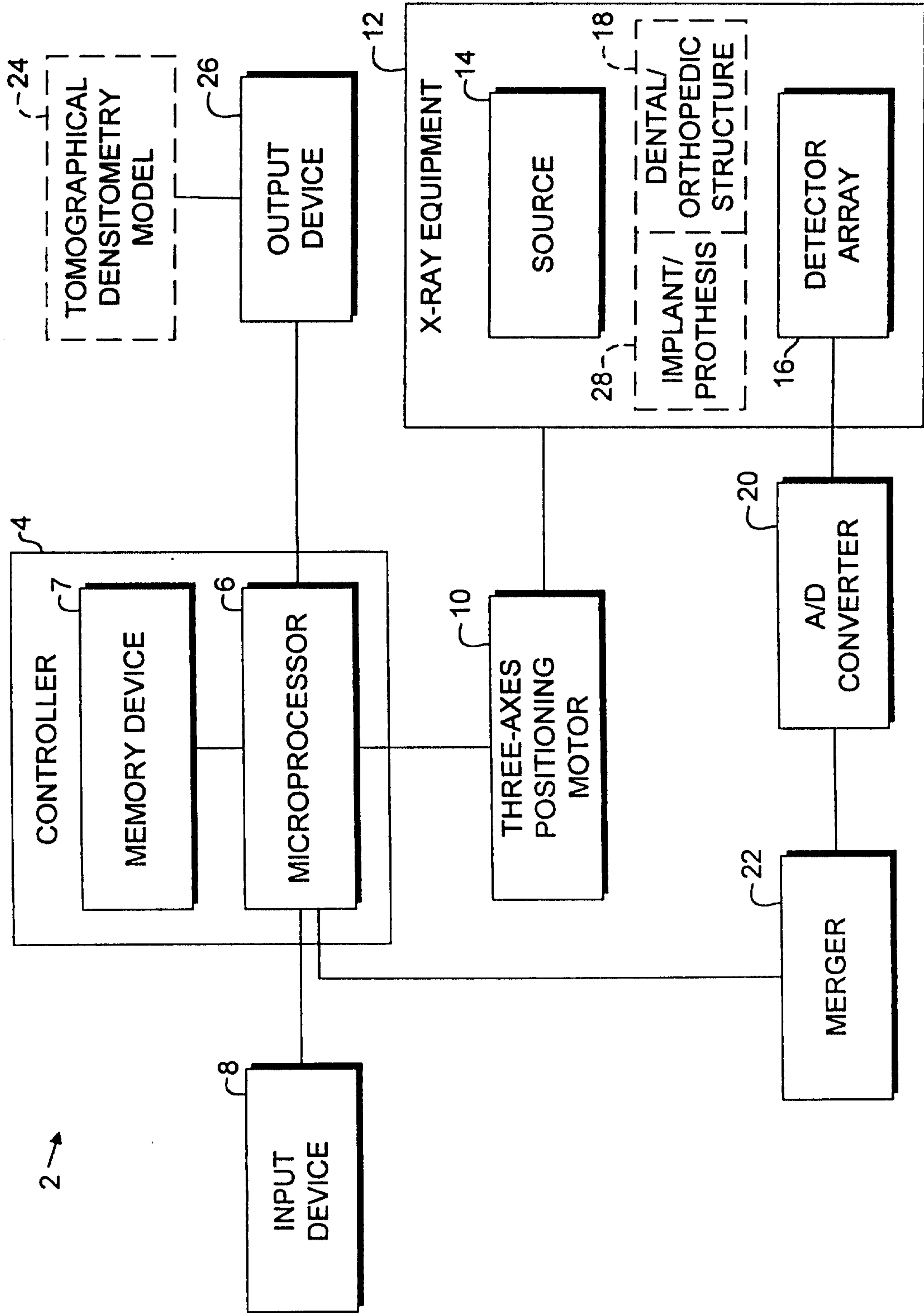

Fig. 1

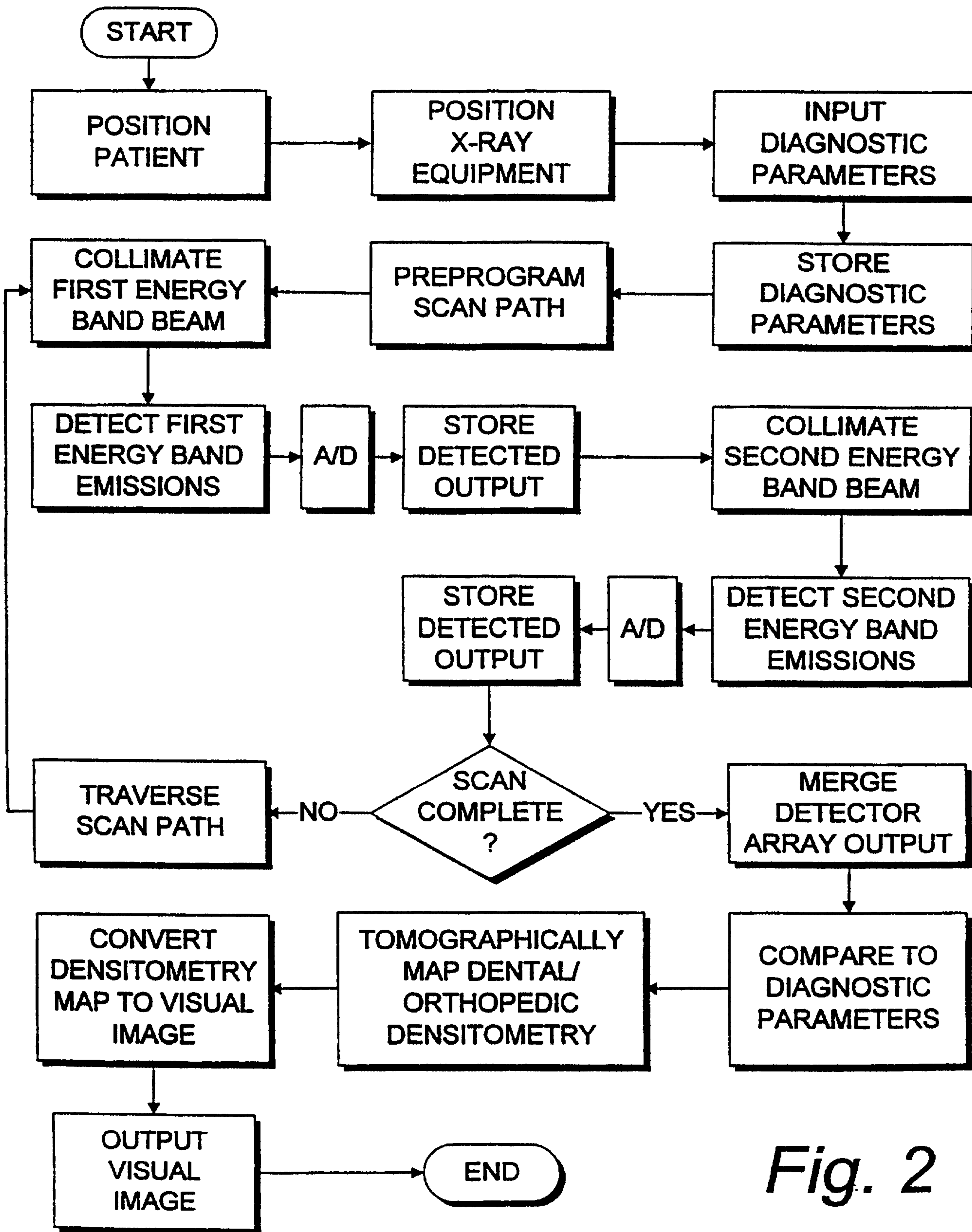

Fig. 2

