

(19)
(12)

(KR)
(Y1)

(51) 。 Int. Cl. 7
E06B 1/26

(45)
(11)
(24)

2003 06 09
20-0315123
2003 05 20

(21) 20-2003-0004162 ()
(22) 2003 02 08
(62) 2003-0006657
: 2003 01 28

(73) 346-2

51

(72) 51

51

:

가 :

(54) 가

(+) (日) ,

가 () ,

(가) ()

1

2 (A)

3 (A) , 가

4

5 (A')

6 (+)

7

(1)-

(2)-

(3)-

(4)- ()

(5)-

(6)-

(7)-

(8)-

(9)-

(10)-

(11)-

(12)-

(13)-

(14)-

(15)-

(16)-

(17)-

(18)-

(19)-

(+) (日)) . (;
 () ;
 가 1990-0012252 (7) , (7)
 7 ,)
 , 가
) (가 가 (가 가 가)
 가 . (가 가 가)
 가 .

((16) (17)) , .
 (4) , (6) (5) (1) (5)
 (3) (1) (2) (4) (5) (1)
 (1) (5) (4) ,
 (10) (9) ;
 (8) (5) (3) (7) 가 , (7) 가 .
 (6) (+) , (12) (13)
 .
 (12) (12,13) (14) (10) 3 ,
 (13)가 (8) (11)
 .
 (14) (4) (12,13) (15) , 가
 (4) , , ,

가 6 가 (+) 가 가 (:
가 가).

(11) , 가 , (15)

(20-1990-0012252) 3가

(10) , (2) , (9) : 1
(8) (11) (4) (10)
() (11) ,
() .

3가

가 () .
가 () 가 가
() .

6 (15) (12) , (13)
() , (15) (12),(13)
6 13 가 가
() .

가

(8) , (3) (1)가 (4) 가 (8)
(7) (3) (7) (7)

(9) (16) () 가 .

(17) () 가 .

(8)

(8) (5) (18)
(7)

() 가 (8) (5) 가 .

(7) (7) (5) 가 (8) , (7) (8)
가 가 , (7) (8)

) (5) , (4) , 2 (4) 5 (9) (5)

, 3 (5) (10) (3) (4) (9) 가

(19)

가

(20-1990-0012252) 7

가 , 가 , 가

(57)

1.

(2) , (6) (5) (1) (5) (1) (3) (4) ; (5) (4) (9) ; (5) (3) (7) ; (7) 가 (8)

2.

1 (19)

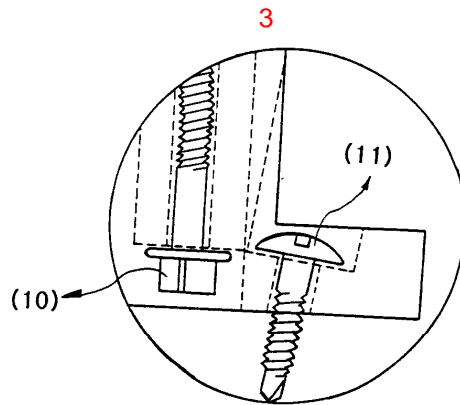
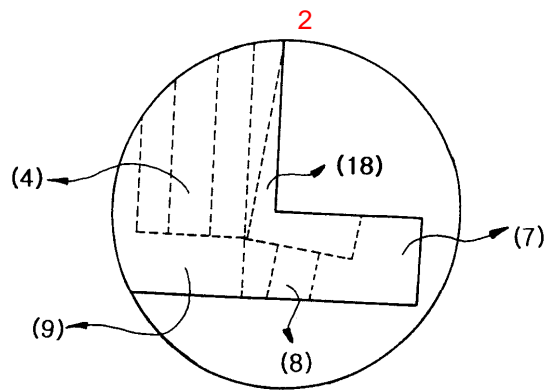
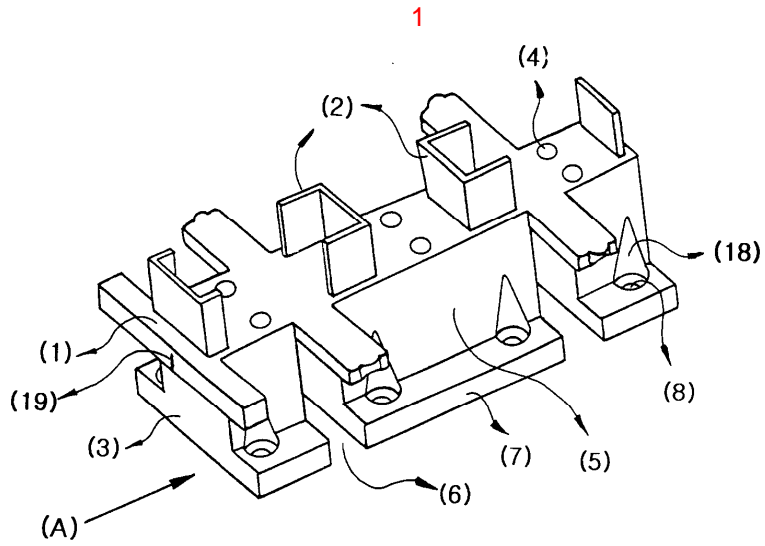

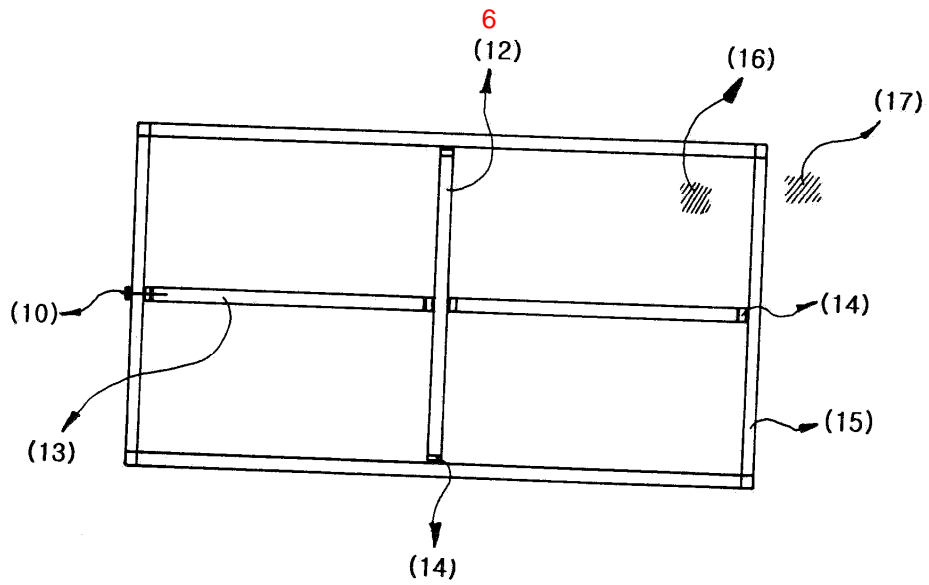
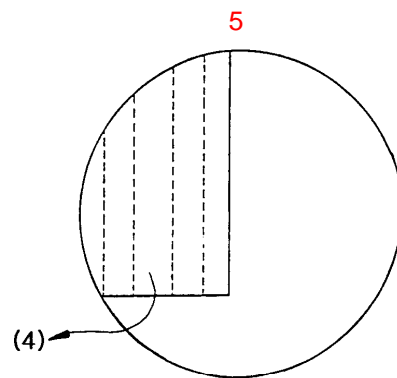
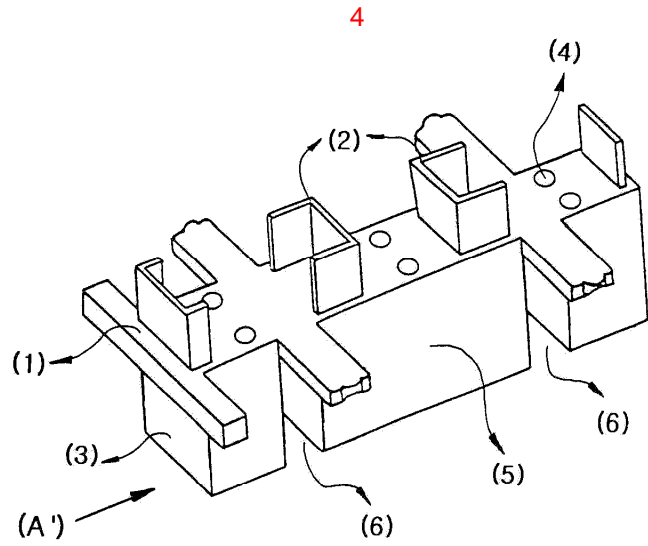

7

