

Feb. 22, 1938.

B. J. VANDOREN

2,108,876

REFRIGERATING APPARATUS

Filed Jan. 23, 1935

2 Sheets-Sheet 1.

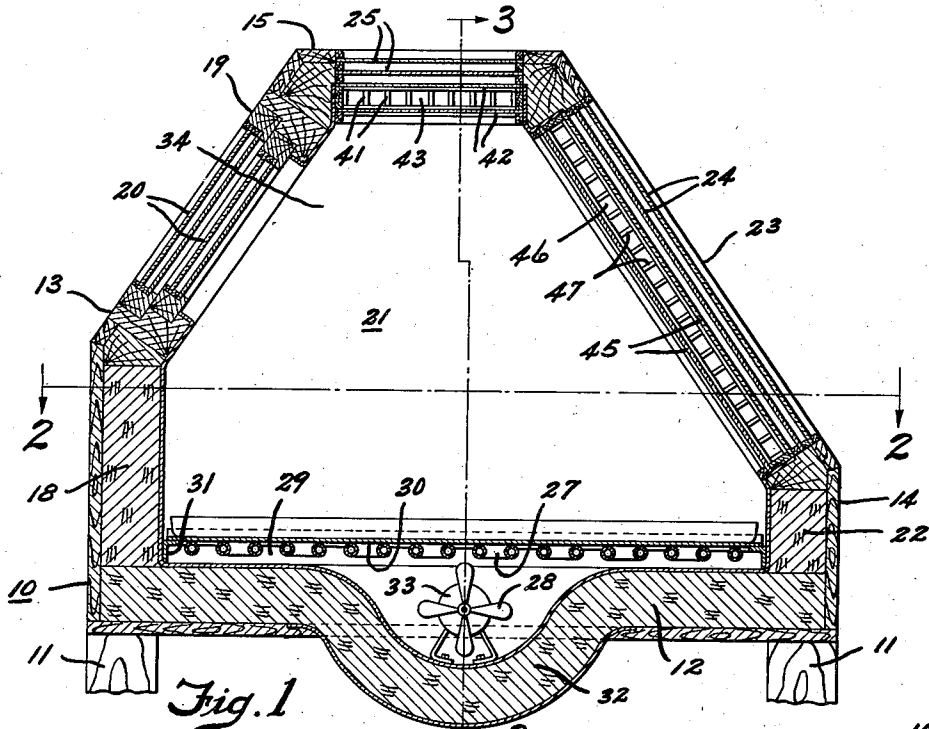

Fig. 1

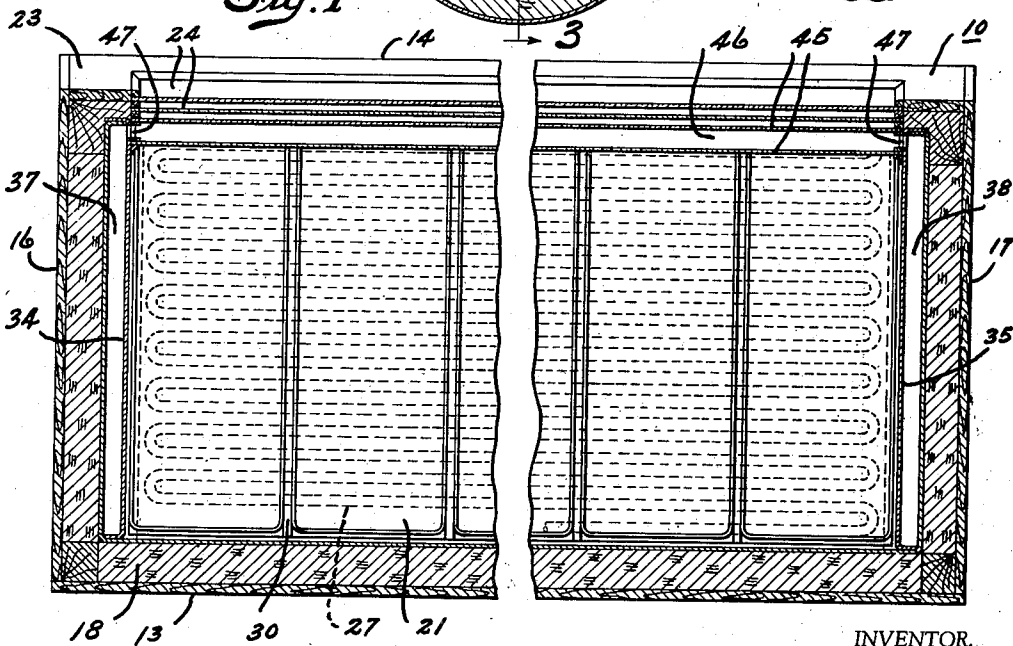

Fig. 2

INVENTOR.
BERNARD J. VANDOREN.

BY
Spencer, Hardman and Felt.
HIS ATTORNEYS.

Feb. 22, 1938.

B. J. VANDOREN

2,108,876

REFRIGERATING APPARATUS

Filed Jan. 23, 1935

2 Sheets-Sheet 2

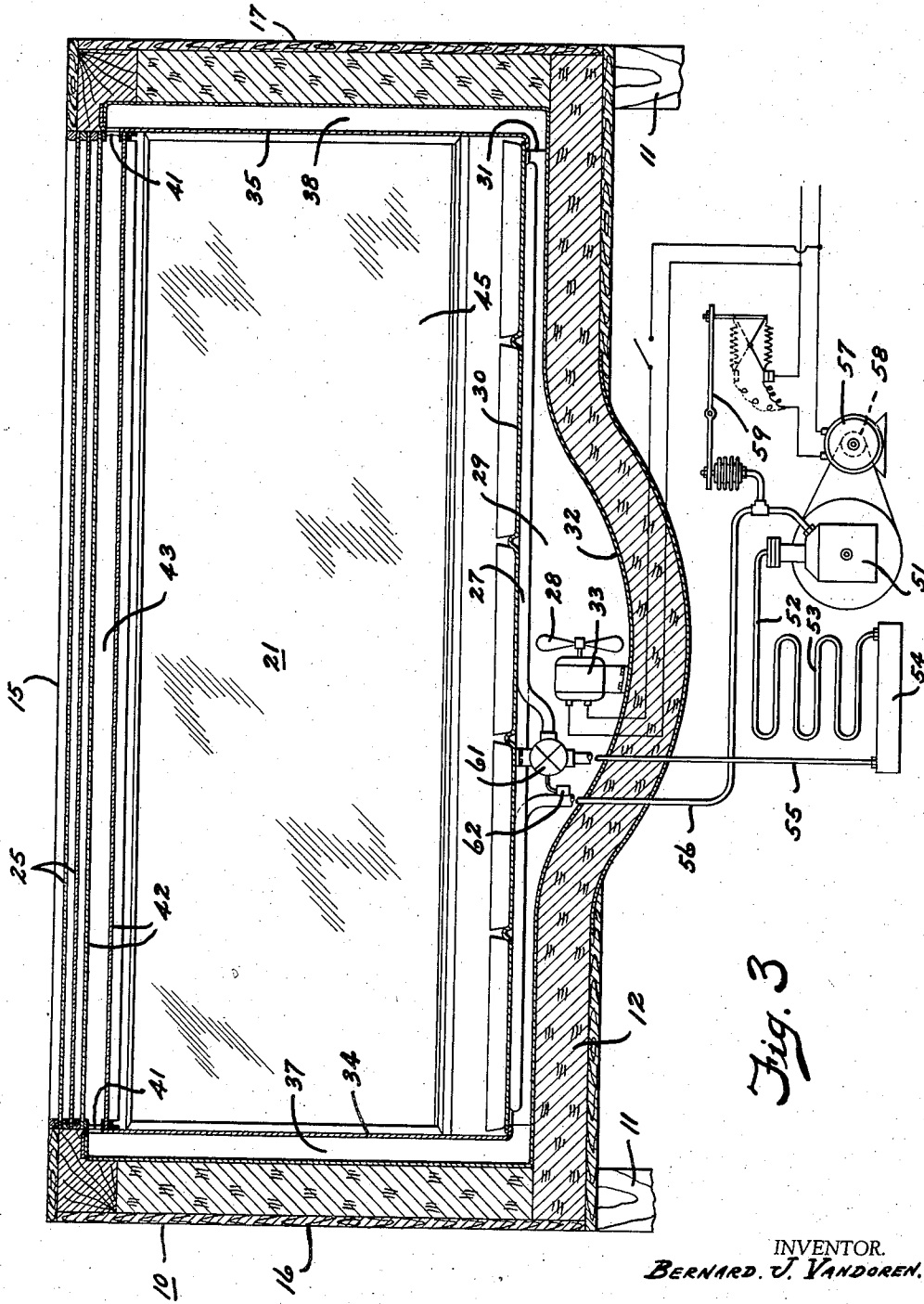

Fig. 3

INVENTOR.
BERNARD. J. VANDOREN.

BY
Spencer, Hardman and Felt.
HIS ATTORNEYS.

UNITED STATES PATENT OFFICE

2,108,876

REFRIGERATING APPARATUS

Bernard J. Vandoren, Dayton, Ohio, assignor to
General Motors Corporation, Dayton, Ohio, a
corporation of Delaware

Application January 23, 1935, Serial No. 3,121

2 Claims. (Cl. 62—89.5)

This invention relates to refrigerating apparatus and particularly to mechanically refrigerated cabinets of the display or showcase type.

One of the objects of the invention is to provide an improved method of cooling the interior of, and food products stored in, a refrigerator cabinet having a plurality of transparent walls.

Another object of the present invention is to provide a refrigerator cabinet of the display or showcase type in which the food products stored therein are visible from the exterior of the cabinet while at the same time being isolated from air circulated over a cooling element or evaporator located within the cabinet and employed to cool the products.

In carrying out the foregoing objects, it is a still further object of the invention to provide a food storage compartment within a display type refrigerator cabinet which compartment is isolated from air cooled by a cooling element mounted in the cabinet and which compartment includes a transparent wall portion forming an air passage adjacent a transparent insulating wall or window of the cabinet.

Further objects and advantages of the present invention will be apparent from the following description, reference being had to the accompanying drawings, wherein a preferred form of the present invention is clearly shown.

In the drawings:

Fig. 1 is a vertical sectional view of a refrigerator cabinet of the display type having my invention embodied therein;

Fig. 2 is a horizontal sectional view of the cabinet taken on the lines 2—2 of Fig. 1; and

Fig. 3 is a vertical sectional view of the cabinet shown in Fig. 1 and taken on the lines 3—3 thereof disclosing a refrigerating system diagrammatically connected with a cooling element installed in the cabinet.

Referring to the drawings, for the purpose of illustrating the invention, there is shown in Fig. 1 thereof a refrigerator cabinet generally designated by the reference character 10. The cabinet 10 is of the so-called display or showcase variety in which food products such as meats, fish, etc., are refrigerated while being displayed for sale and which cabinet may be supported upon any suitable display or supporting device indicated at 11. It is well-known that such cabinets usually include a plurality of windows or transparent glass through which the food products may be viewed. In the present disclosure the cabinet 10 includes a chamber formed by an insulated bottom wall 12, a back wall 13, a front wall 14, top

wall 15 and end walls 16 and 17 respectively. The back wall 13 of cabinet 10 includes a vertically extending non-transparent insulated wall portion 18 and an inclined portion 19 having the transparent windows 20 either pivotally or slidably secured to cabinet 10 to afford access to the food compartment 21. The front wall of cabinet 10 is similar to the rear wall 13 thereof and includes a non-transparent insulated vertical portion 22 and an inclined insulated wall portion 23 comprising a plurality of spaced apart and stationarily mounted transparent glass plate members 24 extending substantially throughout the length of the cabinet. Top wall 15 of cabinet 10 also comprises a plurality of spaced apart and stationarily mounted transparent glass plate members 25 extending substantially throughout the length of the cabinet. The method of mounting the transparent glass plates 24 and 25 and spacing same apart so that they form a dead air or insulating space therebetween is well-known to those skilled in the art of providing a transparent insulated cabinet wall section. The food storage compartment 21 provided in the chamber formed by the cabinet walls is isolated from a passage which extends entirely around the cabinet parallel to and adjacent certain walls thereof in which passage an evaporator or cooling unit 27 of a refrigerating system is disposed. The evaporator 27 is adapted to cool air within the passage and a fan or blower device 28 may be employed for causing a positive circulation of air over the evaporator and around certain walls of compartment 21. A refrigerated air passage 29 adjacent the cabinet bottom wall 12 is formed by a plate member 30 and extends entirely across the bottom of the cabinet. The loops or turns of the conduit forming the evaporator 27 of the refrigerating system are secured to the plate member 30. This plate member 30 is spaced by the angle iron members 31 a suitable distance from the surface of the bottom wall 12 of cabinet 10 so as to provide an air circulating zone below compartment 21 and the evaporator 27 in passage 29. The cabinet bottom wall 12 is depressed as at 32 to provide space in the passage 29 for the mounting of a motor 33, utilized for operating the blower or fan 28, and for positioning a suitable means to control flow of refrigerant to the evaporator. It will be noted (see Fig. 3) that the passage 29 formed by the plate 30 and the angle iron members 31 extends over substantially the full length and width of the cabinet 10. At the ends 16 and 17 of cabinet 10 I provide upright plate members 34 and 35 respectively

(see Fig. 3) which are spaced a suitable distance from the inner surface of the cabinet walls 16 and 17 to form the vertical passages 37 and 38. The lower ends of the plate members 34 and 35 may be secured to the plate 30 and the upper ends thereof may be secured at the top of the cabinet 10 to the inner lining of the cabinet to seal the passages 37 and 38 in communicative relation with the passage 29. The passages 37 and 38 may be of the same configuration as the ends 16 and 17 of cabinet 10 and the members 34 and 35 forming same are provided at the top thereof with a plurality of openings formed by perforating the plate members 34 and 35 as indicated at 41. Below the transparent glass plates 25 located in and forming the top insulated wall 15 of cabinet 10 I mount a pair of transparent glass plates 42 which are stationarily secured in spaced apart relation and sealed at their edges in any suitable manner well-known to those skilled in the art. The space between these glass plates 42 provides or forms the passage 43 and this passage communicates at its ends with the passages 37 and 38 by means of the openings formed by the reticulations or perforations 41 in the members 34 and 35. The inclined portion 23 of front wall 14 of cabinet 10 is also provided with a passage which extends the length thereof adjacent the glass plate members 24. I mount a pair of transparent glass plates 45 which are secured in spaced apart relation and sealed at their edges, in any suitable and well-known manner, to provide the passage 46. Passage 46 is adjacent and parallel to the inner glass plate 24 and extends throughout substantially the full length of the cabinet 10. The ends of passage 46 communicate with the vertical passages 37 and 38 by means of openings, formed by perforated portions 47, also provided in the members 34 and 35. The passages 29, 37, 43, 46 and 38 are thus in open communication with one another to provide a continuous closed passage extending parallel to and adjacent the bottom 12, top 15, front 14, and both end walls 16 and 17 of the cabinet 10. The passages 43 and 46 obviously permit the contents of the food storage compartment to be seen from the exterior of the cabinet, through the transparent glass walls or windows 24 and 25, since these passages are formed by the transparent glass plates 42 and 45.

The refrigerating system connected to the evaporator 27 includes a compressor 51 (see Fig. 3) which compresses the refrigerant of the refrigerating system and forwards the compressed refrigerant through a conduit 52 to a condenser 53 which is cooled in any suitable and well-known manner. Cooling of the condenser causes the compressed refrigerant to be liquefied and the liquid refrigerant is collected in the receiver 54. Liquid refrigerant is forwarded from receiver 54 through the supply conduit 55 to the cooling element or evaporator 27. Liquid refrigerant in evaporator 27 vaporizes, because of the absorption of heat from the refrigerator cabinet 10, and is returned to or drawn into the compressor 51 through the refrigerant return conduit 56. An electric motor 57, connected through a suitable belt and pulley means 58 is employed for driving the compressor 51. Operation of the electric motor 57 and compressor 51 connected therewith is controlled by a switch means 59 actuated by changes in pressure in the low pressure portion of the refrigerating system. The flow of refrigerant to evaporator 27 is controlled by an expansion valve or device 61 interposed in the

conduit 55 which leads to evaporator 27. The valve or device 61 is actuated by pressure in a thermostatic bulb 62 mounted on and responsive to the temperature of the outlet conduit 56 leading from the evaporator. The valve 61 stops flow of refrigerant to evaporator 27 when the temperature of the evaporator reaches a predetermined low limit and the switch 59 will thereafter open the circuit to motor 57 to stop operation of the motor and compressor 51.

The fan or blower 28, located in the passage 29, provided in the cabinet 10, is employed to cause forced circulation of air from passage 29 to passage 35 and through the passages 45 and 46 to passage 37 and thence back to the inlet end of passage 29 and over the evaporator 27. The motor 33 employed to operate fan 28 may be connected with a source of electrical supply through the switch means 59 so as to operate only when the refrigerating apparatus operates or it may be connected with the source of electrical supply so as to operate continuously. If desired a temperature responsive switch or a manually actuated switch may be provided in the power line leading to the fan motor 33 for automatically or manually controlling its operation. In either event it is to be understood that the fan 28 forces the air, cooled by the refrigerating effect produced by evaporator 27, across and parallel to certain walls of the refrigerator cabinet 10, through the passages enumerated, to cool the entire interior of the food compartment 21 by conduction through the inner walls of the passages. The outer walls of the air passages about the cabinet walls pick up heat tending to enter the cabinet and dissipate this heat to the cold air in the passage which in turn gives up heat to the evaporator 27 from where it is carried away from the cabinet 10 by the refrigerating system. The passages 29, 35, 43, 46 and 37 are constructed and arranged to prevent the air cooled by the evaporator 27 and circulated by the fan 28 from entering the food storage compartment 21 of cabinet 10. The refrigerated air, which is dried by its circulation over the evaporator 27 in the well-known manner, does not come in contact with food products stored in the compartment 21 of the cabinet and therefore this dry air cannot cause dehydration of the products. The compartment 21 and food products stored therein are refrigerated by conduction of cold, produced by the evaporator 27, through the metal plate 30 which forms the bottom wall of compartment 21 and is adapted to receive and support a plurality of trays or receptacles containing the food products to be refrigerated.

It will be seen therefore that the food products stored in the compartment 21 of cabinet 10 will be maintained at a desirable low temperature for preservation without causing dehydration thereof in order that they may retain their moisture content which provides freshness and palatability. It will also be seen that I have provided an improved refrigerator cabinet of the display or showcase type wherein cold air passages are provided adjacent and along transparent walls or windows thereof for preventing the transference of heat therethrough to the food compartment without impairing the visibility of food products in the compartment. The provision of the cold air passages in the walls of my improved display cabinet or showcase causes air within the isolated food compartment to circulate and the formation of warm air pockets or zones in the upper portion of the food compartment is pre-

vented. The movement of air within the isolated food compartment insures that products stored therein will be uniformly cooled.

5 While the form of embodiment of the invention as herein disclosed, constitutes a preferred form, it is to be understood that other forms might be adopted, all coming within the scope of the claims which follow.

What is claimed is as follows:

10 1. A refrigerating apparatus comprising in combination, a cabinet having a plurality of insulated walls forming a chamber therein, means cooperating with said walls to form a food storage compartment within said chamber, said
15 means being constructed and arranged to extend continuously around at least four sides of said food compartment, said means providing a closed path for the flow of air around said compartment and having a portion thereof forming a
20 support for food adapted to be stored in said compartment, a cooling element of a refrigerating system positioned in said chamber and isolated by said means from the interior of said compartment, and said cooling element extending along and lying against the food supporting portion of said means and being arranged in position

to be traversed by air flowing around said compartment in said closed path of flow therefor.

2. A refrigerating apparatus comprising in combination, a cabinet having a plurality of insulated walls forming a chamber therein, at least
5 a portion of one of said cabinet walls being transparent, means cooperating with said walls to form a food storage compartment within said chamber, said means being constructed and arranged to extend continuously around at least
10 four sides of said food compartment, said means providing a closed path for the flow of air around said compartment and having a portion thereof forming a support for food adapted to be stored
15 in said compartment, said means also including a transparent portion disposed adjacent to and in alignment with said transparent portion of said one cabinet wall, a cooling element of a refrigerating system positioned in said chamber
20 and isolated by said means from the interior of said compartment, and said cooling element extending along and lying against the food supporting portion of said means and being arranged in position to be traversed by air flowing around said compartment in said closed path of flow therefor.

BERNARD J. VANDOREN.