

L. PAGET.

DYNAMO OR MAGNETO ELECTRIC MACHINE.

No. 522,083.

Patented June 26, 1894.

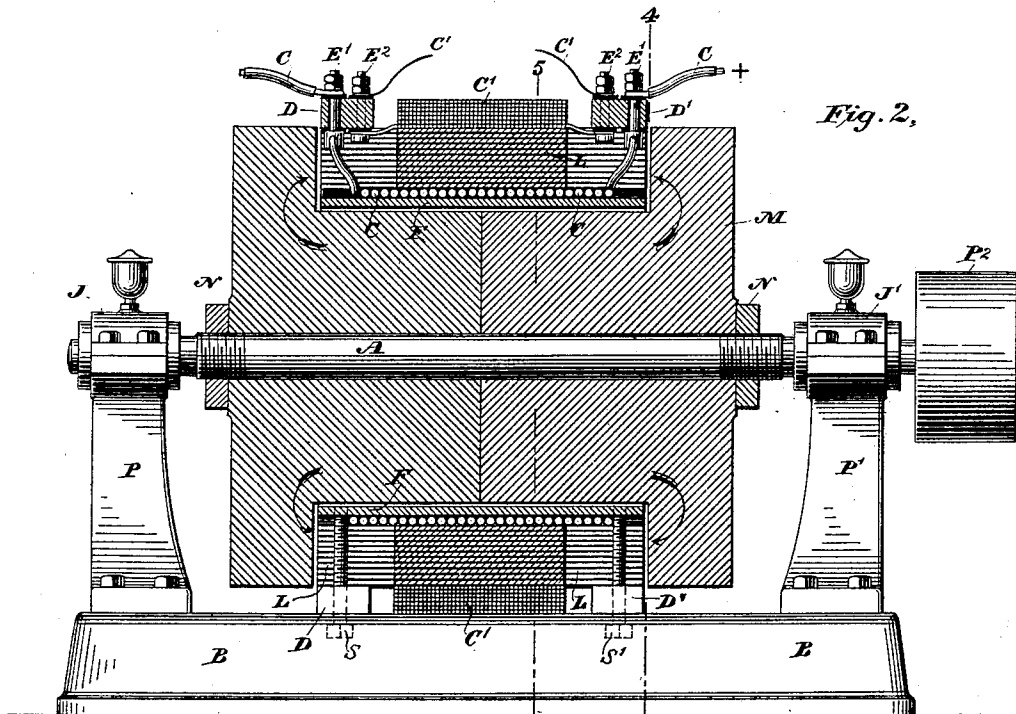
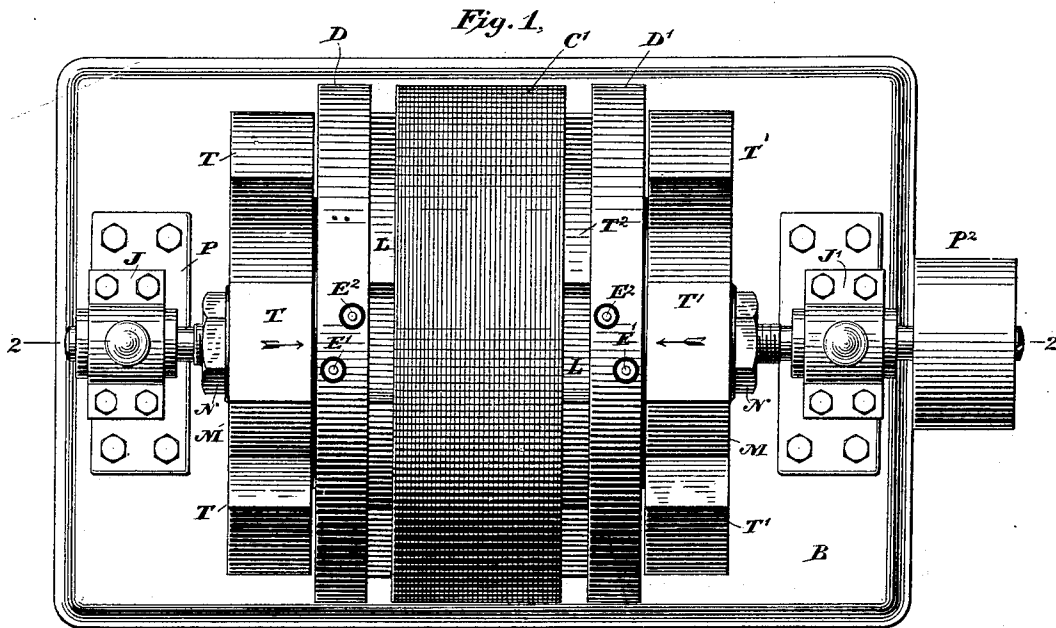

Witnesses  
 Geo. W. Drexel  
 C. E. Ashley

Inventor  
 Leonard Paget  
 By his Attorney  
 Charles J. Kintner

L. PAGET.  
DYNAMO OR MAGNETO ELECTRIC MACHINE.

No. 522,083.

Patented June 26, 1894.

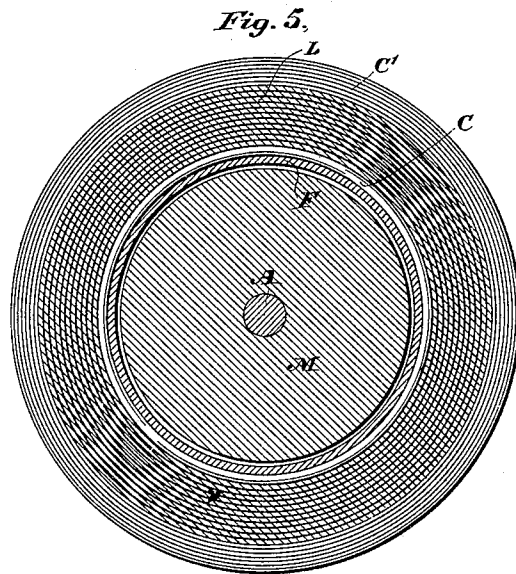
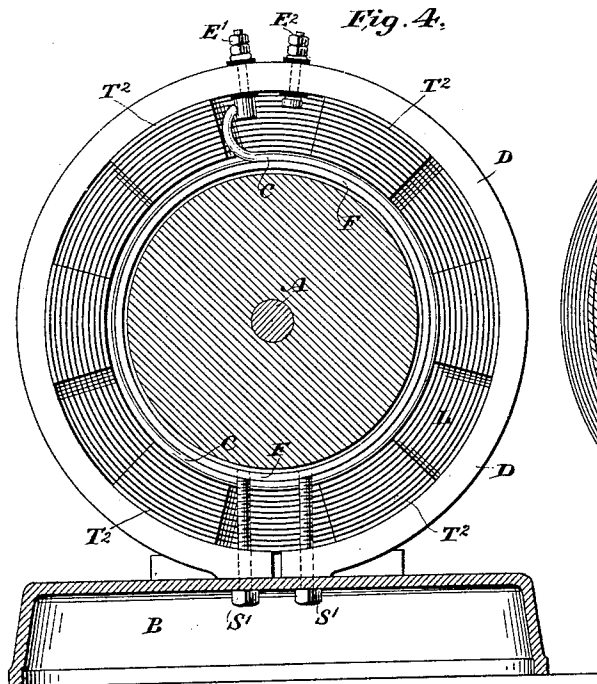
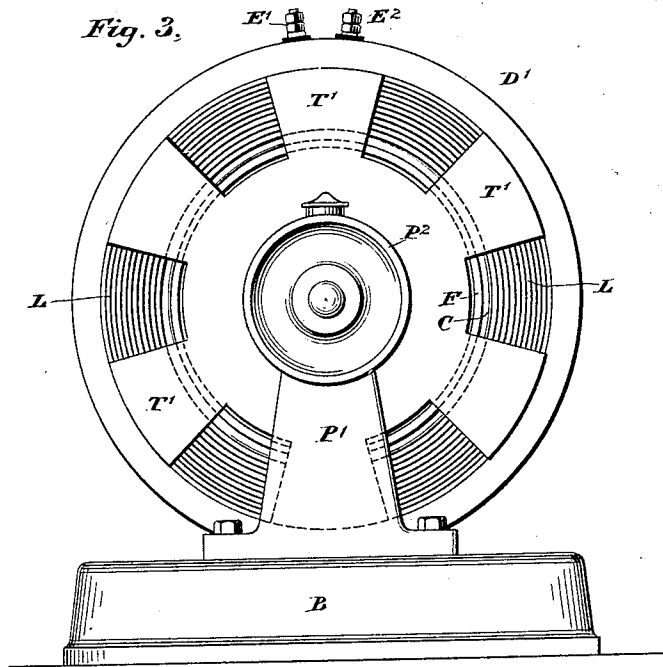

Witnesses  
*Geo. W. Dreck*  
*C. C. Ashley*

Inventor  
*Samuel Paget*  
 By his Attorney  
*Charles J. Kintner*

# UNITED STATES PATENT OFFICE.

LEONARD PAGET, OF NEW YORK, N. Y., ASSIGNOR OF ONE-HALF TO  
CHARLES J. KINTNER, OF SAME PLACE.

## DYNAMO OR MAGNETO ELECTRIC MACHINE.

SPECIFICATION forming part of Letters Patent No. 522,083, dated June 26, 1894.

Application filed June 20, 1889. Serial No. 315,003. (No model.)

*To all whom it may concern:*

Be it known that I, LEONARD PAGET, a citizen of the United States, residing in the city of New York, county of New York, and State of New York, have made a new and useful invention in Dynamo or Magneto Electrical Machines, of which the following specification, taken in connection with the accompanying drawings, is such a full, clear, and exact description as will enable any one skilled in the art to construct and use the invention.

My invention relates particularly to improvements in that type of magneto or dynamo electric machines, known as alternating current generators, and its objects are, first, to simplify and cheapen the construction of this type of generators; second, to devise a magneto or dynamo machine without a commutator or contacting brushes; third, to render the whole apparatus more compact than is possible with the existing forms of magneto or dynamo electric machines. I accomplish these objects with the apparatus hereinafter described, but particularly pointed out in the claims which follow this specification.

Referring to the drawings, in which like letters of reference represent like parts, wherever used, Figure 1 is a plan view of my improved magneto or dynamo machine. Fig. 2, is a longitudinal sectional view of that portion of the machine, between the upright standards which support the axle of the rotary part, said sectional view being taken on line 2—2, Fig. 1. Fig. 3, is an end elevation seen looking at Fig. 1, from right to left. Fig. 4, is a cross section of the entire machine, taken on line 4—4, Fig. 2, and as viewed from right to left. Fig. 5, is a similar cross sectional view, taken on line 5—5 Fig. 2.

—B— is the base which supports the entire machine.

P P<sup>1</sup>, are upright pillars bolted to the base —B— and supporting the shaft —A— of the rotary part through the agency of the journal boxes, J J<sup>1</sup>, said journal boxes being preferably provided with Babbitt metal journal bearings, so that the shaft is magnetically insulated from the base of the machine, should the base or the upright pillars, P P<sup>1</sup>, be of cast

iron or other magnetic material, as is customary.

—M— is the rotary part of the machine consisting of two cylindrical parts of magnetic metal, which are held in position upon the shaft —A—, either by keys or by nuts N N. The outer ends of the part —M— are provided with teeth, —T T<sup>1</sup>—, which are integral therewith. I have shown six of such teeth on each end, located at equal distances apart, but any preferred number may be used, the essential feature being that there shall be the same number of teeth on each end, and in alignment with each other, as clearly shown in Fig. 1.

—D D<sup>1</sup>—, are two non-magnetic non-continuous supporting rings, which are held to the base —B—, of the machine, by screws —S S<sup>1</sup>—, extending through them and into the ends of the laminated fixed or stationary portion of the machine, consisting preferably of annealed sheet iron wound spirally upon itself. This fixed or stationary portion is provided at its ends with the same number of teeth as are found upon the ends of the rotary part, and they are arranged in sets, in alignment with each other, and with the teeth, —T T<sup>1</sup>—, of the rotating part, when the latter are in the position shown in Fig. 1 so that there is a magnetic short circuit between the teeth, —T T<sup>1</sup>—, and those of the stationary part, at this time as indicated by the arrows in Fig. 2.

—F— is a magnetic cylinder, which is held in position by the ends of the screws —S S<sup>1</sup>—, passing through the non-magnetic rings —D D<sup>1</sup>—, and the core of the stationary part as before described, the ends of said screws penetrating said cylinder and holding it firmly in position. Additional screws may be arranged around the circumference of the rings —D D<sup>1</sup>—, at various positions for holding said cylinder in place.

—C— is the primary wire consisting of one or more layers of insulated wire, wound around the cylinder —F— and attached at its opposite ends, to the binding posts —E'—, said binding posts being insulated from the rings —D D<sup>1</sup>—, and said wire being connected at its opposite terminals, to a constant source

of electrical energy, not shown, as a direct current dynamo, or a primary or secondary battery.

—C<sup>1</sup>—, is the secondary wire wound in several layers, about the exterior of the core —L— of the stationary part and having its terminals connected to the binding posts —E<sup>2</sup>—, —E<sup>2</sup>—, from which the circuit runs to the translating devices not shown.

In the construction of the machine it will of course be necessary to first build the stationary part, by winding the primary wire about the central magnetic cylinder —F—, the core is then wound in spiral form around the primary circuit, and the non-magnetic rings, D— and D<sup>1</sup>—, are fitted snugly over its ends, and the necessary screw holes drilled through them, and the core, and into the shield —F—, after which the parts are bolted to the base and together. It will of course be understood that the teeth, which constitute the pole pieces of the stationary part, are cut out before the machine is set up. Two halves of the rotary part —M— are then slid into position upon the shaft —A—, which is inserted through the stationary part. The nuts, —N—, are then firmly set so as to hold the teeth in alignment, and the pillars —P P<sup>1</sup>—, and the journal boxes J J<sup>1</sup>—, are fixed in place, the necessary connections having been made to the energizing source, through the wires —C<sup>1</sup>—, and the pulley —P<sup>2</sup>—, having been fixed to the shaft —A—, the machine is now in condition for operation.

This operation is as follows—The current from the primary source through the conductors —C—, magnetizes the shield —F— and with it, the rotary part —M— giving all of those teeth —T<sup>1</sup>—, on the right, north polarity, and all of those on the left —T<sup>1</sup>—, south polarity. As the part M is rotated, these teeth, T T<sup>1</sup>—, are carried past the teeth of the stationary part and there result magnetic short circuits through the core of the stationary part and the rotary part, so that there follows, a series of phases, which set up in the secondary circuit, —C<sup>1</sup>—, alternating impulses.

I do not limit myself to the specific construction shown, as it is obvious that other constructions might be devised for producing these magnetic phases, as for instance, I might re-place the electro-magnetic rotary

part —M—, with a permanent magnet, thereby, doing away with the primary circuit and the shield —F—.

Having thus described my invention, what I claim, and desire to secure by Letters Patent of the United States, is—

1. A magneto or dynamo electric machine, having a rotary part with projecting pole pieces in combination with a fixed or stationary part having corresponding projecting pole pieces and a single coil wound about said fixed or stationary part, substantially as described.

2. A magneto or dynamo electric machine, having a rotary part with projecting teeth in combination with a fixed or stationary part which surrounds said rotary part, and is also provided with projecting teeth and a single coil which surrounds both the rotary and the stationary parts, substantially as described.

3. In a magneto or dynamo electric machine, the combination of a cylindrical rotary part of magnetic material, having radially projecting teeth at each end, arranged in sets of two, in combination with a core surrounding said rotary part, and having a similar number of pairs of teeth, and a single coil wound about said core, substantially as described.

4. A magneto or dynamo electric machine, having a cylindrical rotary part provided with radially projecting teeth at its ends, in combination with a magnetic cylinder surrounding said rotary part, and carrying a primary inducing coil with a cylindrical fixed or stationary part surrounding said coil, the latter being provided with a single coil, wound in the plane of rotation of the rotary part substantially as described.

5. A magneto or dynamo electric machine, having a cylindrical rotary part of magnetic material in combination with a single coil wound around a cylinder of magnetic material in close proximity to the rotary part with a fixed or stationary core around said coil, and a secondary coil wound around the stationary core, the direction of winding both coils, being in the plane of rotation of the rotary part substantially as described.

LEONARD PAGET.

Witnesses:

ANNIE DUNNELL,  
WM. C. C. MATHEWS.