

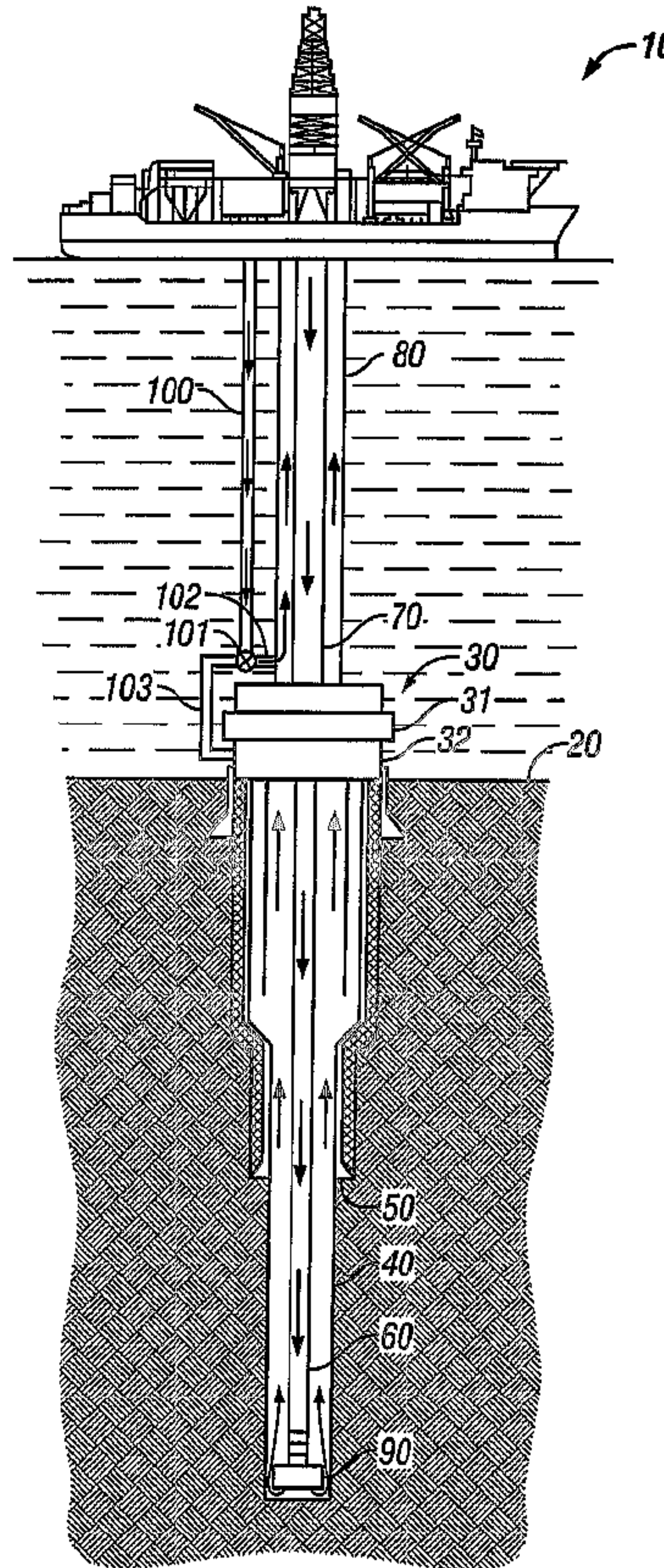

(86) Date de dépôt PCT/PCT Filing Date: 2004/03/16
 (87) Date publication PCT/PCT Publication Date: 2004/09/30
 (45) Date de délivrance/Issue Date: 2011/08/23
 (85) Entrée phase nationale/National Entry: 2005/09/16
 (86) N° demande PCT/PCT Application No.: US 2004/007879
 (87) N° publication PCT/PCT Publication No.: 2004/083596
 (30) Priorité/Priority: 2003/03/17 (US10/390,528)

(51) Cl.Int./Int.Cl. *E21B 15/02* (2006.01),
E21B 19/09 (2006.01), *E21B 7/12* (2006.01)
 (72) Inventeur/Inventor:
DE BOER, LUC, US
 (73) Propriétaire/Owner:
DE BOER, LUC, US
 (74) Agent: FINLAYSON & SINGLEHURST

(54) Titre : SYSTEME ET PROCEDE DE TRAITEMENT DE BOUE DE FORAGE DANS DES APPLICATIONS DE FORAGE DE PUIXS DE GAZ ET DE PETROLE
 (54) Title: SYSTEM AND METHOD FOR TREATING DRILLING MUD IN OIL AND GAS WELL DRILLING APPLICATIONS



(57) **Abrégé/Abstract:**

A system and method for controlling drilling mud density at a location either at the seabed (or just above the seabed) or alternatively below the seabed of wells in deep water and ultra deep water applications are disclosed. The present invention combines a base

(57) **Abrégé(suite)/Abstract(continued):**

fluid of lesser density than the mud required at the wellhead to produce a diluted mud in the riser. By combining the appropriate quantities of drilling mud with base fluid, a riser mud density at or near the density of seawater may be achieved. The present invention also includes a wellhead injection device for injecting the base fluid into the rising drilling mud. The riser charging lines are used to carry the low density base fluid to the injection device for injection into the return mud. At the surface, the diluted return mud is passed through a treatment system to cleanse the mud of drill cuttings and to separate the heavier drilling mud from the lighter base fluid. The present invention further includes a control unit for manipulating drilling fluid systems and displaying drilling and drilling fluid data.

(12) INTERNATIONAL APPLICATION PUBLISHED UNDER THE PATENT COOPERATION TREATY (PCT)

(19) World Intellectual Property
Organization
International Bureau



(43) International Publication Date
30 September 2004 (30.09.2004)

PCT

(10) International Publication Number
WO 2004/083596 A1

- (51) International Patent Classification⁷: **E21B 15/02**, 19/09, 7/12
- (21) International Application Number: PCT/US2004/007879
- (22) International Filing Date: 16 March 2004 (16.03.2004)
- (25) Filing Language: English
- (26) Publication Language: English
- (30) Priority Data: 10/390,528 17 March 2003 (17.03.2003) US
- (71) Applicant and
(72) Inventor: **DE BOER, Luc** [NL/US]; 7516 Olympia Drive, Houston, TX 77063-1919 (US).
- (74) Agent: **CURFISS, Robert, C.**; Jackson Walker L.L.P., 112 E. Pecan Street, Suite 2100, San Antonio, TX 78205 (US).
- (81) Designated States (*unless otherwise indicated, for every kind of national protection available*): AE, AG, AL, AM, AT, AU, AZ, BA, BB, BG, BR, BW, BY, BZ, CA, CH, CN, CO, CR, CU, CZ, DE, DK, DM, DZ, EC, EE, EG, ES, FI, GB, GD, GE, GH, GM, HR, HU, ID, IL, IN, IS, JP, KE, KG, KP, KR, KZ, LC, LK, LR, LS, LT, LU, LV, MA, MD, MG, MK, MN, MW, MX, MZ, NA, NI, NO, NZ, OM, PG, PH, PL, PT, RO, RU, SC, SD, SE, SG, SK, SL, SY, TJ, TM, TN, TR, TT, TZ, UA, UG, US, UZ, VC, VN, YU, ZA, ZM, ZW.
- (84) Designated States (*unless otherwise indicated, for every kind of regional protection available*): ARIPO (BW, GH, GM, KE, LS, MW, MZ, SD, SL, SZ, TZ, UG, ZM, ZW), Eurasian (AM, AZ, BY, KG, KZ, MD, RU, TJ, TM), European (AT, BE, BG, CH, CY, CZ, DE, DK, EE, ES, FI, FR, GB, GR, HU, IE, IT, LU, MC, NL, PL, PT, RO, SE, SI, SK, TR), OAPI (BF, BJ, CF, CG, CI, CM, GA, GN, GQ, GW, ML, MR, NE, SN, TD, TG).

[Continued on next page]

(54) Title: SYSTEM AND METHOD FOR TREATING DRILLING MUD IN OIL AND GAS WELL DRILLING APPLICATIONS

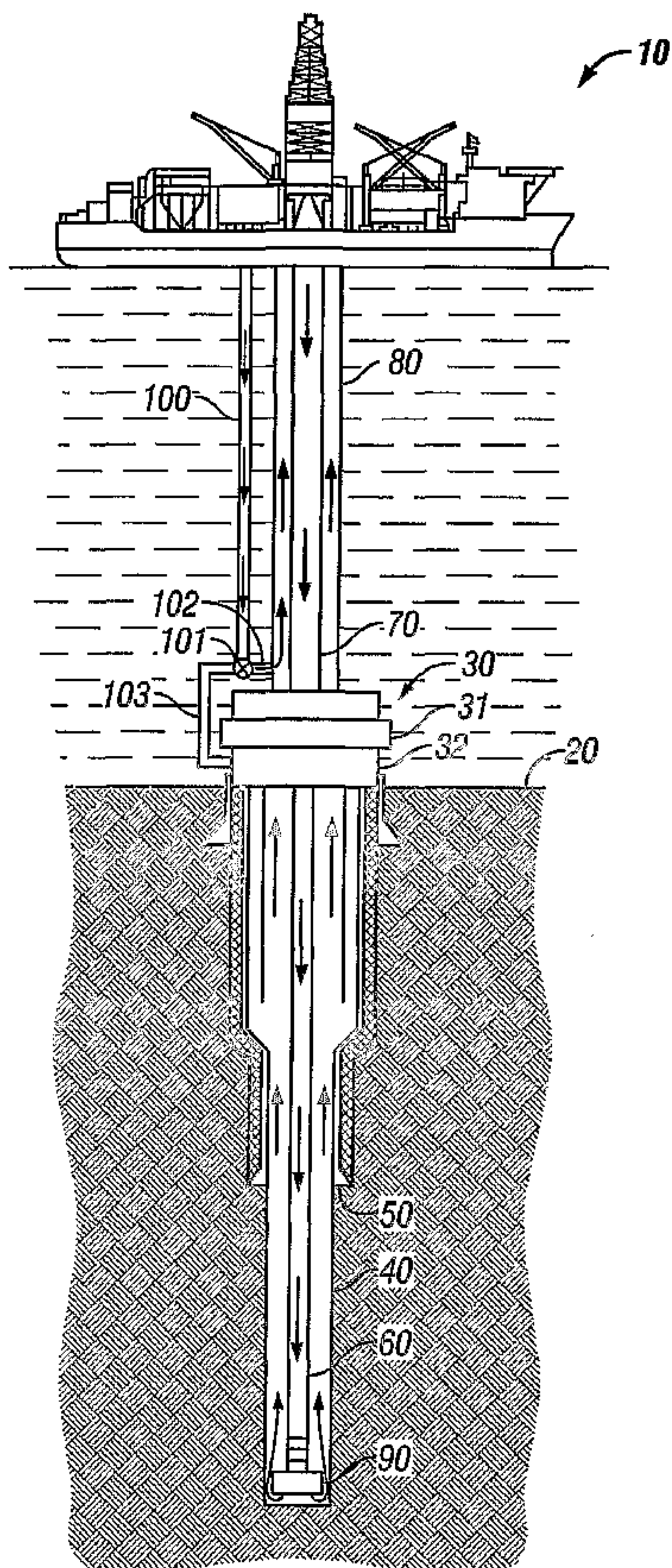

(57) Abstract: A system and method for controlling drilling mud density at a location either at the seabed (or just above the seabed) or alternatively below the seabed of wells in deep water and ultra deep water applications are disclosed. The present invention combines a base fluid of lesser density than the mud required at the wellhead to produce a diluted mud in the riser. By combining the appropriate quantities of drilling mud with base fluid, a riser mud density at or near the density of seawater may be achieved. The present invention also includes a wellhead injection device for injecting the base fluid into the rising drilling mud. The riser charging lines are used to carry the low density base fluid to the injection device for injection into the return mud. At the surface, the diluted return mud is passed through a treatment system to cleanse the mud of drill cuttings and to separate the heavier drilling mud from the lighter base fluid. The present invention further includes a control unit for manipulating drilling fluid systems and displaying drilling and drilling fluid data.

WO 2004/083596 A1

WO 2004/083596 A1



Published:

- *with international search report*
- *before the expiration of the time limit for amending the claims and to be republished in the event of receipt of amendments*

For two-letter codes and other abbreviations, refer to the "Guidance Notes on Codes and Abbreviations" appearing at the beginning of each regular issue of the PCT Gazette.

APPLICATION FOR
UNITED STATES LETTERS PATENT

FOR

SYSTEM AND METHOD FOR TREATING DRILLING MUD
IN OIL AND GAS WELL DRILLING APPLICATIONS

BY

LUC DE BOER

CERTIFICATE OF EXPRESS MAILING

37 C.F.R. § 1.10

I hereby certify that this document and its attachments are being deposited with the United States Postal Service as Express Mail Post Office to Addressee Service, as Express Mail No. EV 323256055 US prior to the last scheduled pickup, in an envelope addressed to Mail Stop PCT, Commissioner for Patents, P.O. Box 1450, Alexandria, Virginia 22313-1450, USA, on the date below:

March 16, 2004
Date

Signature

SYSTEM AND METHOD FOR TREATING DRILLING MUD IN OIL AND GAS WELL DRILLING APPLICATIONS

BACKGROUND OF THE INVENTION

1. Field of the Invention

The subject invention is generally related to systems for delivering drilling fluid (or “drilling mud”) for oil and gas drilling applications. More particularly, the present invention is directed to a system and method for controlling the density of drilling mud in deep water oil and gas drilling applications.

2. Description of the Prior Art

It is well known to use drilling mud to provide hydraulic horse power for operating drill bits, to maintain hydrostatic pressure, to cool the wellbore during drilling operations, and to carry away particulate matter when drilling for oil and gas in subterranean wells. In basic operations, drilling mud is pumped down the drill pipe to provide the hydraulic horsepower necessary to operate the drill bit, and then it flows back up from the drill bit along the periphery of the drill pipe and inside the open borehole and casing. The returning mud carries the particles loosed by the drill bit (i.e., “drill cuttings”) to the surface. At the surface, the return mud is cleaned to remove the particles and then is recycled down into the hole.

The density of the drilling mud is monitored and controlled in order to maximize the efficiency of the drilling operation and to maintain hydrostatic pressure. In a typical application, a well is drilled using a drill bit mounted on the end of a drill stem inserted down the drill pipe. The drilling mud is pumped down the drill pipe and through a series of jets in the drill bit to provide a sufficient force to drive the bit. A gas flow and/or other additives are also pumped into the drill pipe to control the density of the mud. The mud passes through the drill bit and flows upwardly along the drill string inside the open hole and casing, carrying the loosened particles to the surface.

One example of such a system is shown and described in U.S. Patent No. 5,873,420, entitled: “Air and Mud Control System for Underbalanced Drilling”, issued on February 23, 1999 to Marvin

Gearhart. The system shown and described in the Gearhart patent provides for a gas flow in the tubing for mixing the gas with the mud in a desired ratio so that the mud density is reduced to permit enhanced drilling rates by maintaining the well in an underbalanced condition.

5 It is known that there is a preexistent pressure on the formations of the earth, which, in general, increases as a function of depth due to the weight of the overburden on particular strata. This weight increases with depth so the prevailing or quiescent bottom hole pressure is increased in a generally linear curve with respect to depth. As the well depth is doubled in a normal-pressured formation, the pressure is likewise doubled. This is further complicated when drilling in deep water or ultra deep water because of the pressure on the sea floor by the water above it. Thus, high
10 pressure conditions exist at the beginning of the hole and increase as the well is drilled. It is important to maintain a balance between the mud density and pressure and the hole pressure. Otherwise, the pressure in the hole will force material back into the wellbore and cause what is commonly known as a "kick." In basic terms, a kick occurs when the gases or fluids in the wellbore flow out of the formation into the wellbore and bubble upward. When the standing column of
15 drilling fluid is equal to or greater than the pressure at the depth of the borehole, the conditions leading to a kick are minimized. When the mud density is insufficient, the gases or fluids in the borehole can cause the mud to decrease in density and become so light that a kick occurs.

Kicks are a threat to drilling operations and a significant risk to both drilling personnel and the environment. Typically blowout preventers (or "BOP's") are installed at the ocean floor or at the
20 surface to contain the wellbore and to prevent a kick from becoming a "blowout" where the gases or fluids in the wellbore overcome the BOP and flow upward creating an out-of-balance well condition. However, the primary method for minimizing the risk of a blowout condition is the proper balancing of the drilling mud density to maintain the well in a balanced condition at all times. While BOP's can contain a kick and prevent a blowout from occurring thereby minimizing the damage to
25 personnel and the environment, the well is usually lost once a kick occurs, even if contained. It is far more efficient and desirable to use proper mud control techniques in order to reduce the risk of a kick than it is to contain a kick once it occurs.

In order to maintain a safe margin, the column of drilling mud in the annular space around the drill stem is of sufficient weight and density to produce a high enough pressure to limit risk to
30 near-zero in normal drilling conditions. While this is desirable, it unfortunately slows down the drilling process. In some cases underbalanced drilling has been attempted in order to increase the

drilling rate. However, to the present day, the mud density is the main component for maintaining a pressurized well under control.

Deep water and ultra deep water drilling has its own set of problems coupled with the need to provide a high density drilling mud in a wellbore that starts several thousand feet below sea level. The pressure at the beginning of the hole is equal to the hydrostatic pressure of the seawater above it, but the mud must travel from the sea surface to the sea floor before its density is useful. It is well recognized that it would be desirable to maintain mud density at or near seawater density (or 8.6 PPG) when above the borehole and at a heavier density from the seabed down into the well. In the past, pumps have been employed near the seabed for pumping out the returning mud and cuttings from the seabed above the BOP's and to the surface using a return line that is separate from the riser. This system is expensive to install, as it requires separate lines, expensive to maintain, and very expensive to run. Another experimental method employs the injection of low density particles -- such -- as glass beads into the returning fluid in the riser above the sea floor to reduce the density of the returning mud as it is brought to the surface. Typically, the BOP stack is on the sea floor and the glass beads are injected above the BOP stack.

While it has been proven desirable to reduce drilling mud density at a location near and below the seabed in a wellbore, there are no prior art techniques that effectively accomplish this objective.

SUMMARY OF THE INVENTION

The present invention is directed at a method and apparatus for controlling drilling mud density in deep water or ultra deep water drilling applications.

It is an important aspect of the present invention that the drilling mud is diluted using a base fluid. The base fluid is of lesser density than the drilling mud required at the wellhead. The base fluid and drilling mud are combined to yield a diluted mud.

In a preferred embodiment of the present invention, the base fluid has a density less than seawater (or less than 8.6 PPG). By combining the appropriate quantities of drilling mud with base fluid, a riser mud density at or near the density of seawater may be achieved. It can be assumed that the base fluid is an oil base having a density of approximately 6.5 PPG. Using an oil base mud system, for example, the mud may be pumped from the surface through the drill string and into the bottom of the wellbore at a density of 12.5 PPG, typically at a rate of around 800 gallons per minute

in a 12-1/4 inch hole. The fluid in the riser, which is at this same density, is then diluted above the sea floor or alternatively below the sea floor with an equal amount or more of base fluid through the riser charging lines. The base fluid is pumped at a faster rate, say 1500 gallons per minute, providing a return fluid with a density that can be calculated as follows:

5

$$[(F_{Mi} \times Mi) + (F_{Mb} \times Mb)] / (F_{Mi} + F_{Mb}) = Mr,$$

where:

F_{Mi} = flow rate F_i of fluid,

F_{Mb} = flow rate F_b of base fluid into riser charging lines,

10 Mi = mud density into well,

Mb = mud density into riser charging lines, and

Mr = mud density of return flow in riser.

In the above example:

Mi = 12.5 PPG,

15 Mb = 6.5 PPG,

F_{Mi} = 800 gpm, and

F_{Mb} = 1500 gpm.

Thus the density Mr of the return mud can be calculated as:

$Mr = ((800 \times 12.5) + (1500 \times 6.5)) / (800 + 1500) = 8.6$ PPG. The flow rate, F_r , of the mud having the density Mr in the riser is the combined flow rate of the two flows, F_i , and F_b . In the example, this is:

$$F_r = F_i + F_b = 800 \text{ gpm} + 1500 \text{ gpm} = 2300 \text{ gpm}.$$

The return flow in the riser is a mud having a density of 8.6 PPG (or the same as seawater) flowing at 2300gpm.

25 It is another important aspect of the present invention that the return flow is treated at the surface in accordance with the mud treatment system of the present invention. The mud is returned to the surface and the cuttings are separated from the mud using a shaker device. While the cuttings are transported in a chute to a dryer (or alternatively discarded overboard), the cleansed return mud falls into riser mud tanks or pits. The return mud pumps are used to carry the drilling mud to a separation skid which is preferably located on the deck of the drilling rig. The separation skid includes: (1) return mud pumps, (2) a centrifuge device to strip the base fluid having density Mb

30

from the return mud to achieve a drilling fluid with density M_i , (3) a base fluid collection tank for gathering the lighter base fluid stripped from the drilling mud, and (4) a drilling fluid collection tank to gather the heavier drilling mud having a density M_i . Hull tanks for storing the base fluid are located beneath the separation skid such that the base fluid can flow from the stripped base fluid collection tank into the hull tank. A conditioning tank is located beneath the separation skid such that the stripped drilling fluid can flow from the drilling fluid collection tank into conditioning tanks. Once the drilling fluid is conditioned in the conditioning tanks, the drilling fluid flows into active tanks located below the conditioning tanks. As needed, the cleansed and stripped drilling fluid can be returned to the drill string via a mud manifold using the mud pumps, and the base fluid can be re-inserted into the riser stream via charging lines or choke and kill lines, or alternatively into a concentric riser using base fluid pumps.

It is yet another important aspect of the present invention that the mud recirculation system includes a multi-purpose control unit for manipulating drilling fluid systems and displaying drilling and drilling fluid data.

It is an object and feature of the subject invention to provide a method and apparatus for diluting mud density in deep water and ultra deep water drilling applications for both drilling units and floating platform configurations.

It is another object and feature of the subject invention to provide a method for diluting the density of mud in a riser by injecting low density fluids into the riser lines (typically the charging line or booster line or possibly the choke or kill line) or riser systems with surface BOP's.

It is also an object and feature of the subject invention to provide a method of diluting the density of mud in a concentric riser system with subsea or surface BOP's.

It is yet another object and feature of the subject invention to provide a method for diluting the density of mud in a riser by injecting low density fluids into the riser charging lines or riser systems with a below-seabed wellhead injection apparatus.

It is a further object and feature of the subject invention to provide an apparatus for separating the low density and high density fluids from one another at the surface.

Other objects and features of the invention will be readily apparent from the accompanying drawing and detailed description of the preferred embodiment.

BRIEF DESCRIPTION OF THE DRAWINGS

Fig. 1 is a schematic of a typical offshore drilling system modified to accommodate the teachings of the present invention depicting drilling mud being diluted with a base fluid at or above the seabed.

5 Fig. 2 is a schematic of a typical offshore drilling system modified to accommodate the teachings of the present invention depicting drilling mud being diluted with a base fluid below the seabed.

Fig. 3 is an enlarged sectional view of a below-seabed wellhead injection apparatus in accordance with the present invention for injecting a base fluid into drilling mud below the seabed.

10 Fig. 4 is a graph showing depth versus down hole pressures in a single gradient drilling mud application.

Fig. 5 is a graph showing depth versus down hole pressures and illustrates the advantages obtained using multiple density muds injected at the seabed versus a single gradient mud.

15 Fig. 6 is a graph showing depth versus down hole pressures and illustrates the advantages obtained using multiple density muds injected below the seabed versus a single gradient mud.

Fig. 7 is a diagram of the drilling mud treatment system in accordance with the present invention for stripping the base fluid from the drilling mud at or above the seabed.

Fig. 8 is a diagram of control system for monitoring and manipulating variables for the drilling mud treatment system of the present invention.

20 Fig. 9 is an enlarged elevation view of a conventional solid bowl centrifuge as used in the treatment system of the present invention to separate the low-density material from the high-density material in the return mud.

DESCRIPTION OF A PREFERRED EMBODIMENT OF THE PRESENT INVENTION

25 With respect to FIGS. 1-2, a mud recirculation system for use in offshore drilling operations to pump drilling mud: (1) downward through a drill string to operate a drill bit thereby producing drill cuttings, (2) outward into the annular space between the drill string and the formation of the wellbore where the mud mixes with the cuttings, and (3) upward from the wellbore to the surface via a riser in accordance with the present invention is shown. A platform 10 is provided from which
30 drilling operations are performed. The platform 10 may be an anchored floating platform or a drill ship or a semi-submersible drilling unit. A series of concentric strings runs from the platform 10 to

the sea floor or seabed 20 and into a stack 30. The stack 30 is positioned above a wellbore 40 and includes a series of control components, generally including one or more blowout preventers or BOP's 31. The concentric strings include casing 50, tubing 60, a drill string 70, and a riser 80. A drill bit 90 is mounted on the end of the drill string 70. A riser charging line (or booster line) 100 runs from the surface to a switch valve 101. The riser charging line 100 includes an above-seabed section 102 running from the switch valve 101 to the riser 80 and a below-seabed section 103 running from the switch valve 101 to a wellhead injection apparatus 32. The above-seabed charging line section 102 is used to insert a base fluid into the riser 80 to mix with the upwardly returning drilling mud at a location at or above the seabed 20. The below-seabed charging line section 103 is used to insert a base fluid into the wellbore to mix with the upwardly returning drilling mud via a wellhead injection apparatus 32 at a location below the seabed 20. The switch valve 101 is manipulated by a control unit to direct the flow of the base fluid into either the above-seabed charging line section 102 or the below-seabed charging line section 103. While this embodiment of the present invention is described with respect to an offshore drilling rig platform, it is intended that the mud recirculation system of the present invention can also be employed for land-based drilling operations.

With respect to FIG. 3, the wellhead injection apparatus 32 for injecting a base fluid into the drilling mud at a location below the seabed is shown. The injection apparatus 32 includes: (1) a wellhead connector 200 for connection with a wellhead 300 and having an axial bore therethrough and an inlet port 201 for providing communication between the riser charging line 100 (FIG. 3) and the wellbore; and (2) an annulus injection sleeve 400 having a diameter less than the diameter of the axial bore of the wellhead connector 200 attached to the wellhead connector thereby creating an annulus injection channel 401 through which the base fluid is pumped downward. The wellhead 300 is supported by a wellhead body 302 which is cemented in place to the seabed.

In a preferred embodiment of the present invention, the wellhead housing 302 is a 36 inch diameter casing and the wellhead 300 is attached to the top of a 20 inch diameter casing. The annulus injection sleeve 400 is attached to the top of a 13-3/8 inch to 16 inch diameter casing sleeve having a 2,000 foot length. Thus, in this embodiment of the present invention, the base fluid is injected into the wellbore at a location approximately 2,000 feet below the seabed. While the preferred embodiment is described with casings and casing sleeves of a particular diameter and

length, it is intended that the size and length of the casings and casing sleeves can vary depending on the particular drilling application.

In operation, with respect to FIGS. 1-3, drilling mud is pumped downward from the platform 10 into the drill string 70 to turn the drill bit 90 via the tubing 60. As the drilling mud flows out of the tubing 60 and past the drill bit 90, it flows into the annulus defined by the outer wall of the tubing 60 and the formation 40 of the wellbore. The mud picks up the cuttings or particles loosened by the drill bit 90 and carries them to the surface via the riser 80. A riser charging line 100 is provided for charging (i.e., circulating) the fluid in the riser 80 in the event a pressure differential develops that could impair the safety of the well.

In accordance with a preferred embodiment of the present invention, when it is desired to dilute the rising drilling mud, a base fluid (typically, a light base fluid) is mixed with the drilling mud either at (or immediately above) the seabed or below the seabed. A reservoir contains a base fluid of lower density than the drilling mud and a set of pumps connected to the riser charging line (or booster charging line). This base fluid is of a low enough density that when the proper ratio is mixed with the drilling mud a combined density equal to or close to that of seawater can be achieved. When it is desired to dilute the drilling mud with base fluid at a location at or immediately above the seabed 20, the switch valve 101 is manipulated by a control unit to direct the flow of the base fluid from the platform 10 to the riser 80 via the charging line 100 and above-seabed section 102 (FIG. 1). Alternatively, when it is desired to dilute the drilling mud with base fluid at a location below the seabed 20, the switch valve 101 is manipulated by a control unit to direct the flow of the base fluid from the platform 10 to the riser 80 via the charging line 100 and below-seabed section 103 (FIG. 2).

In a typical example, the drilling mud is an oil based mud with a density of 12.5 PPG and the mud is pumped at a rate of 800 gallons per minute or "gpm". The base fluid is an oil base fluid with a density of 6.5 to 7.5 PPG and can be pumped into the riser charging lines at a rate of 1500 gpm. Using this example, a riser fluid having a density of 8.6 PPG is achieved as follows:

$$M_r = [(F_{M_i} \times M_i) + (F_{M_b} \times M_b)] / (F_{M_i} + F_{M_b}),$$

where:

F_{M_i} = flow rate F_i of fluid,

F_{M_b} = flow rate F_b of base fluid into riser charging lines,

M_i = mud density into well,

M_b = mud density into riser charging lines, and

M_r = mud density of return flow in riser.

In the above example:

M_i = 12.5 PPG,

5 M_b = 6.5 PPG,

F_{Mi} = 800 gpm, and

F_{Mb} = 1500 gpm.

Thus the density M_r of the return mud can be calculated as:

$$M_r = ((800 \times 12.5) + (1500 \times 6.5)) / (800 + 1500) = 8.6 \text{ PPG.}$$

10 The flow rate, F_r , of the mud having the density M_r in the riser is the combined flow rate of the two flows, F_i , and F_b . In the example, this is:

$$F_r = F_i + F_b = 800 \text{ gpm} + 1500 \text{ gpm} = 2300 \text{ gpm.}$$

The return flow in the riser above the base fluid injection point is a mud having a density of 8.6 PPG (or close to that of seawater) flowing at 2300 gpm.

15 Although the example above employs particular density values, it is intended that any combination of density values may be utilized using the same formula in accordance with the present invention.

An example of the advantages achieved using the dual density mud method of the present invention is shown in the graphs of FIGS. 4-6. The graph of FIG. 4 depicts casing setting depths with single gradient mud; the graph of FIG. 5 depicts casing setting depths with dual gradient mud inserted at the seabed; and the graph of FIG. 6 depicts casing setting depths with dual gradient mud inserted below the seabed. The graphs of FIGS. 4-6 demonstrate the advantages of using a dual gradient mud over a single gradient mud. The vertical axis of each graph represents depth and shows the seabed or sea floor at approximately 6,000 feet. The horizontal axis represents mud weight in pounds per gallon or "PPG". The solid line represents the "equivalent circulating density" (ECD) in PPG. The diamonds represents formation frac pressure. The triangles represent pore pressure. The bold vertical lines on the far left side of the graph depict the number of casings required to drill the well with the corresponding drilling mud at a well depth of approximately 23,500 feet. With respect to FIG. 4, when using a single gradient mud, a total of six casings are required to reach total depth (conductor, surface casing, intermediate liner, intermediate casing, production casing, and production liner). With respect to FIG. 5, when using a dual gradient mud

20

25

30

inserted at or just above the seabed, a total of five casings are required to reach total depth (conductor, surface casing, intermediate casing, production casing, and production liner). With respect to FIG. 6, when using a dual gradient mud inserted approximately 2,000 feet below the seabed, a total of four casings are required to reach total depth (conductor, surface casing, production casing, and production liner). By reducing the number of casings run and installed downhole, it will be appreciated by one of skill in the art that the number of rig days and the total well cost will be decreased.

In another embodiment of the present invention, the mud recirculation system includes a treatment system located at the surface for: (1) receiving the return combined mud (with density M_r), (2) removing the drill cuttings from the mud, and (3) stripping the lighter base fluid (with density M_b) from the return mud to achieve the initial heavier drilling fluid (with density M_i).

With respect to FIG. 7, the treatment system of the present invention includes: (1) a shaker device for separating drill cuttings from the return mud, (2) a set of riser fluid tanks or pits for receiving the cleansed return mud from the shaker, (3) a separation skid located on the deck of the drilling rig -- which comprises a centrifuge, a set of return mud pumps, a base fluid collection tank and a drilling fluid collection tank -- for receiving the cleansed return mud and separating the mud into a drilling fluid component and a base fluid component, (4) a set of hull tanks for storing the stripped base fluid component, (5) a set of base fluid pumps for re-inserting the base fluid into the riser stream via the charging line, (6) a set of conditioning tanks for adding mud conditioning agents to the drilling fluid component, (7) a set of active tanks for storing the drilling fluid component, and (8) a set of mud pumps to pump the drilling fluid into the wellbore via the drill string.

In operation, the return mud is first pumped from the riser into the shaker device having an inlet for receiving the return mud via a flow line connecting the shaker inlet to the riser. Upon receiving the return mud, the shaker device separates the drill cuttings from the return mud producing a cleansed return mud. The cleansed return mud flows out of the shaker device via a first outlet, and the cuttings are collected in a chute and bourn out of the shaker device via a second outlet. Depending on environmental constraints, the cuttings may be dried and stored for eventual off-rig disposal or discarded overboard.

The cleansed return mud exits the shaker device and enters the set of riser mud tanks/pits via a first inlet. The set of riser mud tanks/pits holds the cleansed return mud until it is ready to be

separated into its basic components -- drilling fluid and base fluid. The riser mud tanks/pits include a first outlet through which the cleansed mud is pumped out.

The cleansed return mud is pumped out of the set of riser mud tanks/pits and into the centrifuge device of the separation skid by a set of return mud pumps. While the preferred
5 embodiment includes a set of six return mud pumps, it is intended that the number of return mud pumps used may vary depending upon on drilling constraints and requirements. The separation skid includes the set of return mud pumps, the centrifuge device, a base fluid collection tank for gathering the lighter base fluid, and a drilling fluid collection tank to gather the heavier drilling mud.

As shown in FIG. 9, the centrifuge device 500 includes: (1) a bowl 510 having a tapered end
10 510A with an outlet port 511 for collecting the high-density fluid 520 and a non-tapered end 510B having an adjustable weir plate 512 and an outlet port 513 for collecting the low-density fluid 530, (2) a helical (or "screw") conveyor 540 for pushing the heavier density fluid 520 to the tapered end 510A of the bowl 510 and out of the outlet port 511, and (3) a feed tube 550 for inserting the return mud into the bowl 510. The conveyor 540 rotates along a horizontal axis of rotation 560 at a first
15 selected rate and the bowl 510 rotates along the same axis at a second rate which is relative to but generally faster than the rotation rate of the conveyor.

The cleansed return mud enters the rotating bowl 510 of the centrifuge device 500 via the feed tube 550 and is separated into layers 520, 530 of varying density by centrifugal forces such that the high-density layer 520 (i.e., the drilling fluid with density M_i) is located radially outward
20 relative to the axis of rotation 560 and the low-density layer 530 (i.e., the base fluid with density M_b) is located radially inward relative to the high-density layer. The weir plate 512 of the bowl is set at a selected depth (or "weir depth") such that the drilling fluid 520 cannot pass over the weir and instead is pushed to the tapered end 510A of the bowl 510 and through the outlet port 511 by the rotating conveyor 540. The base fluid 530 flows over the weir plate 512 and through the outlet 513 of the
25 non-tapered end 510B of the bowl 510. In this way, the return mud is separated into its two components: the base fluid with density M_b and the drilling fluid with density M_i .

The base fluid is collected in the base fluid collection tank and the drilling fluid is collected in the drilling fluid collection tank. In a preferred embodiment of the present invention, both the base fluid collection tank and the drilling fluid collection tank include a set of circulating jets to
30 circulate the fluid inside the tanks to prevent settling of solids. Also, in a preferred embodiment of the present invention, the separation skid includes a mixing pump which allows a predetermined

volume of base fluid from the base fluid collection tank to be added to the drilling fluid collection tank to dilute and lower the density of the drilling fluid.

The base fluid collection tank includes a first outlet for moving the base fluid into the set of hull tanks and a second outlet for moving the base fluid back into the set of riser mud tanks/pits if further separation is required. If valve V1 is open and valve V2 is closed, the base fluid will feed into the set of hull tanks for storage. If valve V1 is closed and valve V2 is open, the base fluid will feed back into the set of riser fluid tanks/pits to be run back through the centrifuge device.

Each of the hull tanks includes an inlet for receiving the base fluid and an outlet. When required, the base fluid can be pumped from the set of hull tanks through the outlet and re-injected into the riser mud at a location at or below the seabed via the riser charging lines using the set of base fluid pumps.

The drilling fluid collection tank includes a first outlet for moving the drilling fluid into the set of conditioning tanks and a second outlet for moving the drilling fluid back into the set of riser mud tanks/pits if further separation is required. If valve V3 is open and valve V4 is closed, the drilling fluid will feed into the set of conditioning tanks. If valve V3 is closed and valve V4 is open, the drilling fluid will feed back into the set of riser fluid tanks/pits to be run back through the centrifuge device.

Each of the active mud conditioning tanks includes an inlet for receiving the drilling fluid component of the return mud and an outlet for the conditioned drilling fluid to flow to the set of active tanks. In the set of conditioning tanks, mud conditioning agents may be added to the drilling fluid. Mud conditioning agents (or "thinners") are generally added to the drilling fluid to reduce flow resistance and gel development in clay-water muds. These agents may include, but are not limited to, plant tannins, polyphosphates, lignitic materials, and liginosulphates. Also, these mud conditioning agents may be added to the drilling fluid for other functions including, but not limited to, reducing filtration and cake thickness, countering the effects of salt, minimizing the effect of water on the formations drilled, emulsifying oil in water, and stabilizing mud properties at elevated temperatures.

Once conditioned, the drilling fluid is fed into a set of active tanks for storage. Each of the active tanks includes an inlet for receiving the drilling fluid and an outlet. When required, the drilling fluid can be pumped from the set of active tanks through the outlet and into the drill string via the mud manifold using a set of mud pumps.

While the treatment system of the present invention is described with respect to stripping a low-density base fluid from the return mud to achieve the high-density drilling fluid in a dual gradient system, it is intended that treatment system can be used to strip any material -- fluid or solid -- having a density different than the density of the drilling fluid from the return mud. For example, drilling mud in a single density drilling fluid system or "total mud system" comprising a base fluid with barite can be separated into a base fluid component and a barite component using the treatment system of the present invention. In a total mud system, each section of the well is drilled using a drilling mud having a single, constant density. However, as deeper sections of the well are drilled, it is required to use a mud having a density greater than that required to drill the shallower sections. More specifically, the shallower sections of the well may be drilled using a drilling mud having a density of 10 PPG, while the deeper sections of the well may require a drilling mud having a density of 12 PPG. In previous operations, once the shallower sections of the well were drilled with 10 PPG mud, the mud would be shipped from the drilling rig to a location onshore to be treated with barite to form a denser 12 PPG mud. After treatment, the mud would be shipped back offshore to the drilling rig for use in drilling the deeper sections of the well. The treatment system of the present invention, however, may be used to treat the 10 PPG density mud to obtain the 12 PPG density mud without having the delay and expense of sending the mud to and from a land-based treatment facility. This may be accomplished by using the separation unit to draw off and store the base fluid from the 10 PPG mud, thus increasing the concentration of barite in the mud until a 12 PPG mud is obtained. The deeper sections of the well can then be drilled using the 12 PPG mud. Finally, when the well is complete and a new well is begun, the base fluid can be combined with the 12 PPG mud to reacquire the 10 PPG mud for drilling the shallower sections of the new well. In this way, valuable components -- both base fluid and barite -- of a single gradient mud may be stored and combined at a location on the rig to efficiently create a mud tailored to the drilling requirement of a particular section of the well.

In still another embodiment of the present invention, the treatment system includes a circulation line for boosting the riser fluid with drilling fluid of the same density in order to circulate cuttings out the riser. As shown in FIG. 7, when the valve V5 is open, cleansed riser return mud can be pumped from the set of riser mud tanks or pits and injected into the riser stream at a location at or below the seabed. This is performed when circulation downhole below the seabed has stopped through the drill string and no dilution is required.

In yet another embodiment of the present invention, the mud recirculation system includes a multi-purpose software-driven control unit for manipulating drilling fluid systems and displaying drilling and drilling fluid data. With respect to FIG. 8, the control unit is used for manipulating system devices such as: (1) opening and closing the switch valve 101 (see also FIGS. 1 and 2), the control valves V1, V2, V3, and V4, and the circulation line valve V5, (2) activating, deactivating, and controlling the rotation speed of the set of mud pumps, the set of return mud pumps, and the set of base fluid pumps, (3) activating and deactivating the circulation jets, and (4) activating and deactivating the mixing pump. Also, the control unit may be used to adjust centrifuge variables including feed rate, bowl rotation speed, conveyor speed, and weir depth in order to manipulate the heavy fluid discharge.

Furthermore, the control unit is used for receiving and displaying key drilling and drilling fluid data such as: (1) the level in the set of hull tanks and set of active tanks, (2) readings from a measurement-while-drilling (or "MWD") instrument, (3) readings from a pressure-while-drilling (or "PWD") instrument, and (4) mud logging data.

A MWD instrument is used to measure formation properties (e.g., resistivity, natural gamma ray, porosity), wellbore geometry (e.g., inclination and azimuth), drilling system orientation (e.g., toolface), and mechanical properties of the drilling process. A MWD instrument provides real-time data to maintain directional drilling control.

A PWD instrument is used to measure the differential well fluid pressure in the annulus between the instrument and the wellbore while drilling mud is being circulated in the wellbore. A PWD unit provides real-time data at the surface of the well indicative of the pressure drop across the bottom hole assembly for monitoring motor and MWD performance.

Mud logging is used to gather data from a mud logging unit which records and analyzes drilling mud data as the drilling mud returns from the wellbore. Particularly, a mud logging unit is used for analyzing the return mud for entrained oil and gas, and for examining drill cuttings for reservoir quality and formation identification.

While certain features and embodiments have been described in detail herein, it should be understood that the invention includes all of the modifications and enhancements within the scope and spirit of the following claims.

In the afore specification and appended claims: (1) the term "tubular member" is intended to embrace "any tubular good used in well drilling operations" including, but not limited to, "a casing",

“a subsea casing”, “a surface casing”, “a conductor casing”, “an intermediate liner”, “an intermediate casing”, “a production casing”, “a production liner”, “a casing liner”, or “a riser”; (2) the term “drill tube” is intended to embrace “any drilling member used to transport a drilling fluid from the surface to the wellbore” including, but not limited to, “a drill pipe”, “a string of drill pipes”, or “a drill string”; (3) the terms “connected”, “connecting”, “connection”, and “operatively connected” are intended to embrace “in direct connection with” or “in connection with via another element”; (4) the term “set” is intended to embrace “one” or “more than one”; (5) the term “charging line” is intended to embrace any auxiliary riser line, including but not limited to “riser charging line”, “booster line”, “choke line”, “kill line”, or “a high-pressure marine concentric riser”; (6) the term “system variables” is intended to embrace “the feed rate, the rotation speed of the set of mud pumps, the rotation speed of the set of return mud pumps, the rotation speed of the set of base fluid pumps, the bowl rotation speed of the centrifuge, the conveyor speed of the centrifuge, and/or the weir depth of the centrifuge”; (7) the term “drilling and drilling fluid data” is intended to embrace “the contained volume in the set of hull tanks, the contained volume in the set of active tanks, the readings from a MWD instrument, the readings from a PWD instrument, and mud logging data”; and (8) the term “tanks” is intended to embrace “tanks” or “pits”.

What is claimed is:

1. A system for treating return mud rising to the surface from a wellbore via a tubular member in well drilling operations, said return mud comprising a first material having a first density, a second material having a second density which is greater than the first density, and drill cuttings, said system comprising:

(a) a shaker device for receiving the return mud from the tubular member and removing the drill cuttings from the return mud to produce a clean return mud, said shaker device comprising a first outlet capable of passing a dual gradient fluid consisting of said first and second materials and a second outlet capable of passing said drill cuttings;

(b) a centrifuge device comprising a first inlet in fluid communication with said first outlet of said shaker, a first outlet capable of passing said first fluid and a second outlet capable of passing said second fluid;

(c) a first tank in fluid communication with said first outlet of said centrifuge device, said first tank comprising a first outlet;

(d) a second tank in fluid communication with said second outlet of said centrifuge device.

2. The system of claim 1, wherein the first material is base fluid, and the second material is drilling fluid.

3. The system of claim 1, further comprising:

(a) a mud preparation system in fluid communication with said first tank;

(b) a drill string; and

(c) a riser line separate from said drill string, said riser line in fluid communication with said second tank.

4. The system of claim 3, further comprising:

(a) a third tank in fluid communication with the second tank for receiving and

storing the base fluid;

(b) a fourth tank in fluid communication with the first tank for receiving and adding at least one conditioning agent to the drilling fluid; and

(c) a fifth tank in fluid communication with the fourth tank for receiving and storing the drilling fluid.

5. The system of claim 4, further comprising a first pump for circulating the drilling fluid from the fifth tank into the wellbore via a drill tube.

6. The system of claim 5, further comprising a second pump for injecting the base fluid from the third tank into the tubular member.

7. The system of claim 5, further comprising a sixth tank disposed inline between the shaker and the centrifuge device and a second pump for injecting the clean return mud from the sixth tank into the tubular member.

8. The system of claim 5, further comprising means for transferring base fluid from the second tank to a sixth tank disposed inline between the shaker and the centrifuge device.

9. The system of claim 5, further comprising means for transferring drilling fluid from the first tank to a sixth tank disposed inline between the shaker and the centrifuge device.

10. The system of claim 1, further comprising:

(a) a first set of jets in said second tank for circulating the base fluid in the second tank;

(b) a second set of jets in said first tank for circulating the drilling fluid in the first tank; and

(c) a mixing pump in fluid communication with the first and second tanks for

transferring a predetermined volume of base fluid from the second tank to the first tank.

11. The system of claim 10, further comprising a control means for:

- (a) manipulating system variables,
- (b) displaying drilling and drilling fluid data,
- (c) for activating and deactivating the first set of jets,
- (d) for activating and deactivating the second set of jets,
- (e) for activating and deactivating the mixing pumps.

12. The system of claim 1, wherein the first density is lower than 8.6 PPG.

13. The system of claim 12, wherein the first density is 6.5 PPG.

14. The system of claim 1, wherein the first density is lower than the density of seawater and the second density is higher than the density of seawater.

15. A mud treatment system for offshore drilling operations, said system comprising;

(a) a first combination fluid comprising a first fluid having a first density, a second fluid having a second density and a solid particulate material suspended therein;

(b) a shaker device with a first inlet into which said first combination fluid is introduced, wherein said first combination fluid is disposed in said shaker, said shaker further comprising a first outlet and a second outlet;

(c) a second combination fluid comprising the first fluid and the second fluid, wherein said first outlet of said shaker is disposed to receive said second combination fluid and said second outlet of said shaker is disposed to receive said solid particulate matter;

(d) a first tank comprising a storage area, a portion of said second combination fluid disposed therein, a first inlet in fluid communication with the first outlet of said

shaker and a first outlet; and

(e) a centrifuge device having a first inlet in fluid communication with the first outlet of said first tank, a first outlet disposed to receive said first fluid and a second outlet disposed to receive said second fluid.

16. A method employed in well drilling operations at a surface for use in treating a first combination fluid rising to the surface from a wellbore via a tubular member, said first combination fluid comprising a first fluid having a predetermined first density, a second fluid having a predetermined second density, and drill cuttings, said method comprising the steps of:

(a) introducing the first combination fluid at the surface;

(b) removing the drill cuttings from the first combination fluid to produce a second combination fluid comprising the first fluid and the second fluid;

(c) processing the second combination fluid to separate the first fluid and the second fluid from one another; and

(d) storing the first fluid and the second fluid in separate storage units at the surface.

17. The method of claim 16, wherein the first fluid comprises base fluid, and the second fluid comprises drilling fluid.

18. The method of claim 17, further comprising the steps of:

(a) circulating the drilling fluid in the wellbore via a drill tube, and

(b) injecting the base fluid into the tubular member at a location near a seabed.

19. The method of claim 17, further comprising the steps of:

(a) circulating the drilling fluid in the wellbore via a drill tube, and

(b) injecting the base fluid into the tubular member at a location below a seabed.

20. The method of claim 16, wherein the first fluid comprises base fluid, and the second fluid comprises barite.

21. The method of claim 16, further comprising the step of adding at least one conditioning agent to the drilling fluid.

22. A system for treating return mud rising from a wellbore to a surface rig via a tubular member in well drilling operations, said return mud comprising a drilling fluid having a first selected density, a base fluid having a second selected density which is less than the first density of the drilling fluid, and drill cuttings, said surface rig having an operating deck, said system comprising:

(a) a shaker device for receiving the return mud from the tubular member and removing the cuttings from the return mud to produce a clean return mud;

(b) a first set of tanks for receiving the clean return mud from the shaker device and for storing the clean return mud;

(c) a separation unit located above the operating deck of the surface rig for receiving the clean return mud from the first set of tanks and separating the return mud into said drilling fluid and said base fluid, said separation unit comprising: (i) a centrifuge device, (ii) a first set of pumps for pumping the clean return mud from the first set of tanks to the centrifuge device, (iii) a drilling fluid collection tank for receiving the drilling fluid, (iv) and a base fluid collection tank for receiving the base fluid;

(d) a second set of tanks for receiving the drilling fluid from the drilling fluid collection tank and for adding at least one conditioning agent to the drilling fluid;

(e) a third set of tanks for receiving the drilling fluid from the second set of tanks and for storing the drilling fluid;

(f) a fourth set of tanks for receiving the base fluid from the base fluid collection tank and for storing the base fluid;

(g) control means for manipulating system variables and for displaying drilling and drilling fluid data;

(h) a second set of pumps for returning the drilling fluid from the third set of tanks to the wellbore via a drill tube; and

(i) a third set of pumps for re-injecting the base fluid from the fourth set of tanks into the tubular member via a charging line.

23. The system of claim 22, wherein the rig is a land-based rig.

24. The system of claim 22, wherein the rig is an offshore rig.

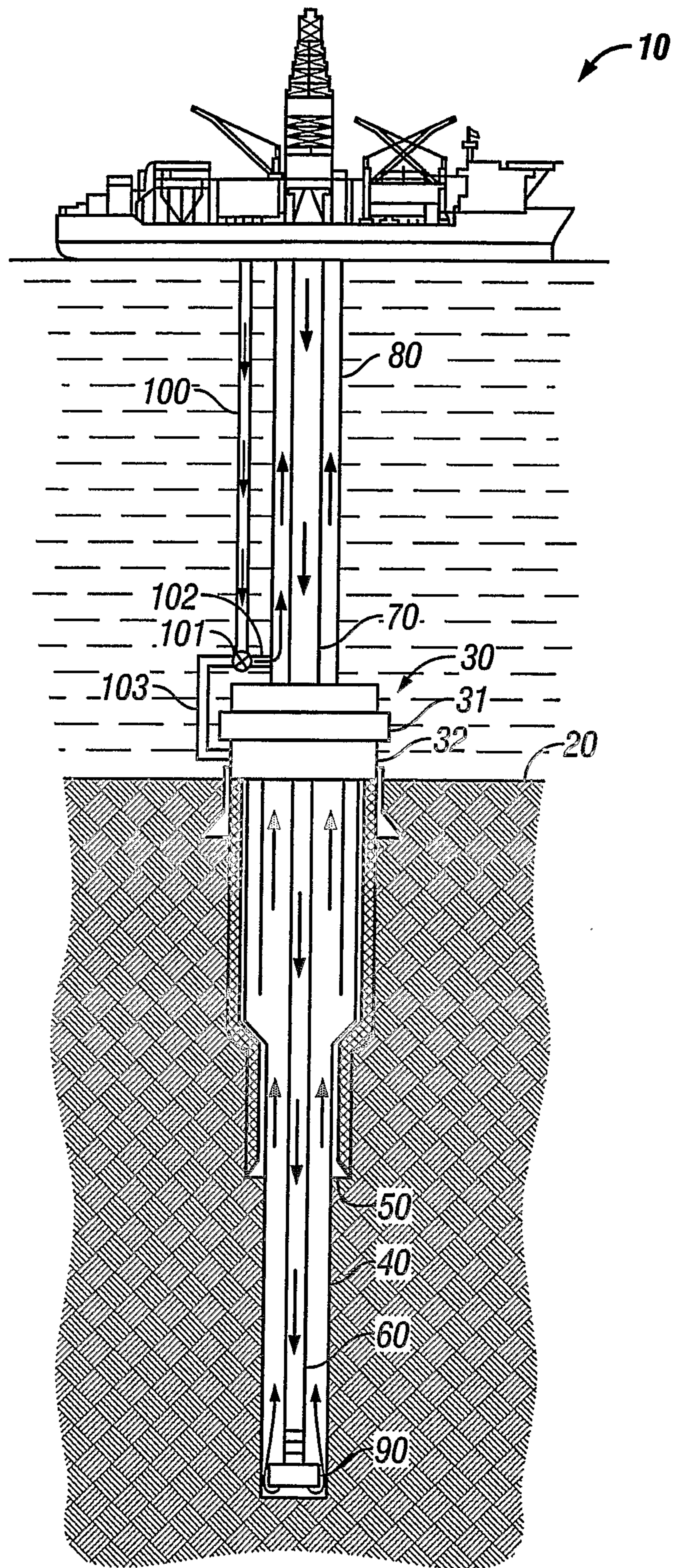

FIG. 1

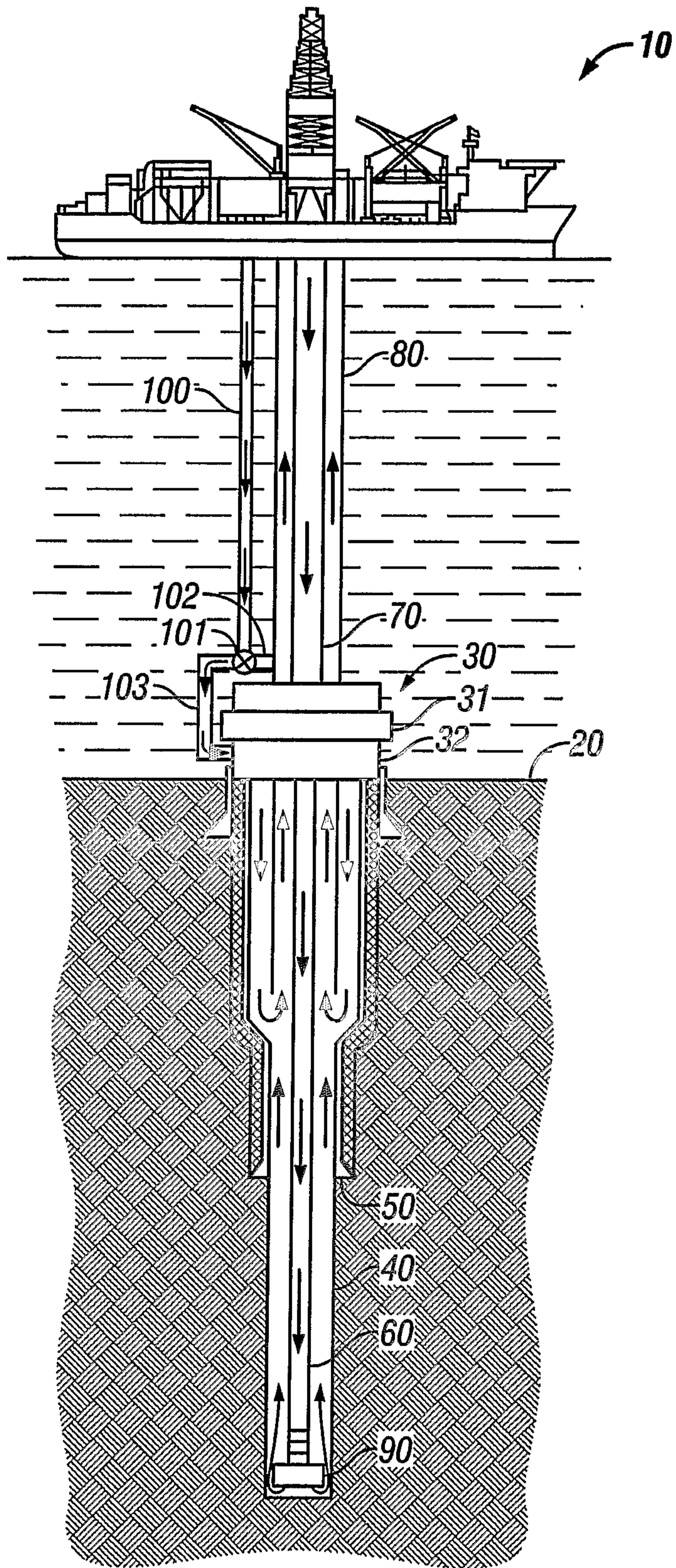

FIG. 2

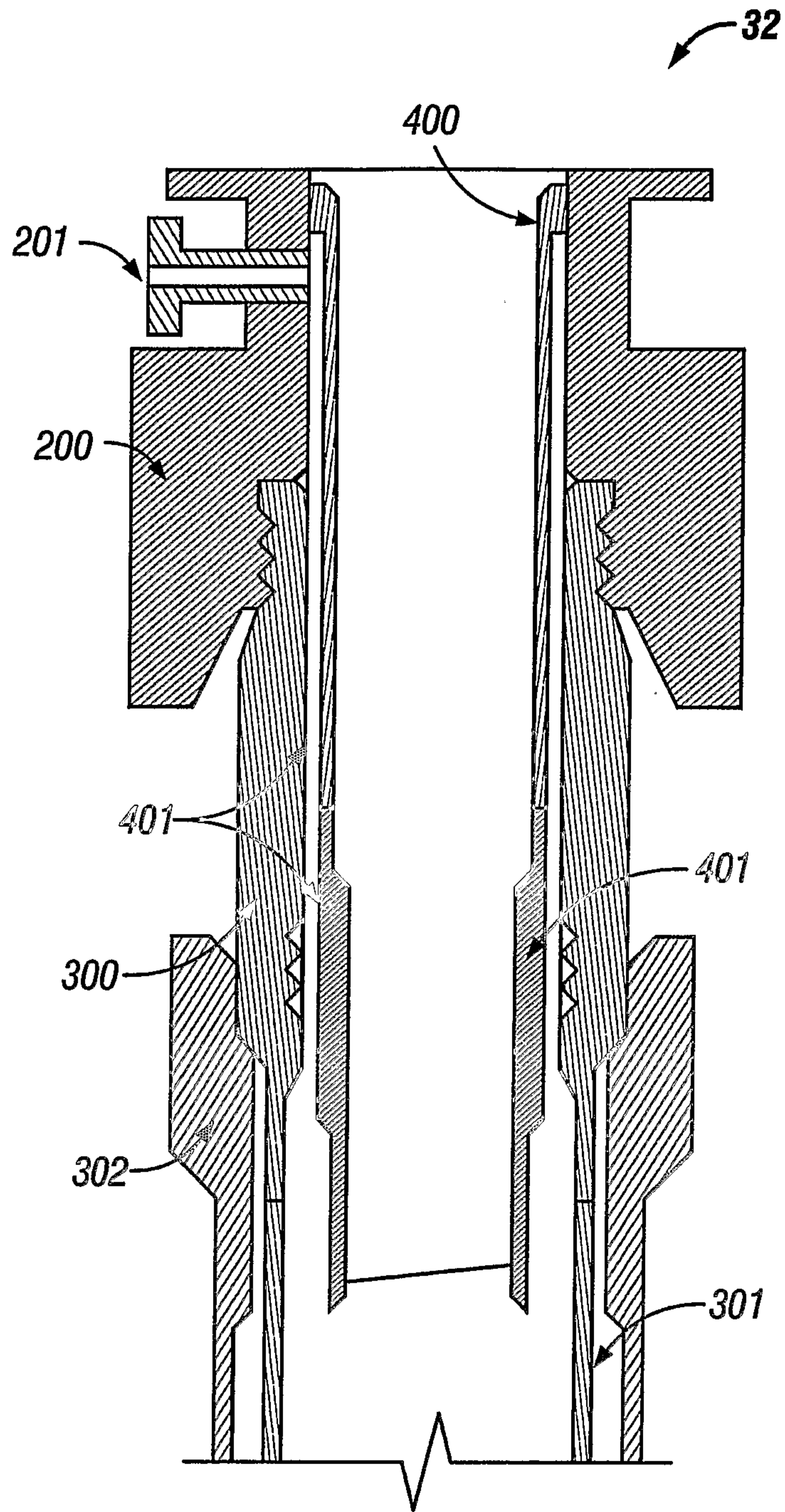
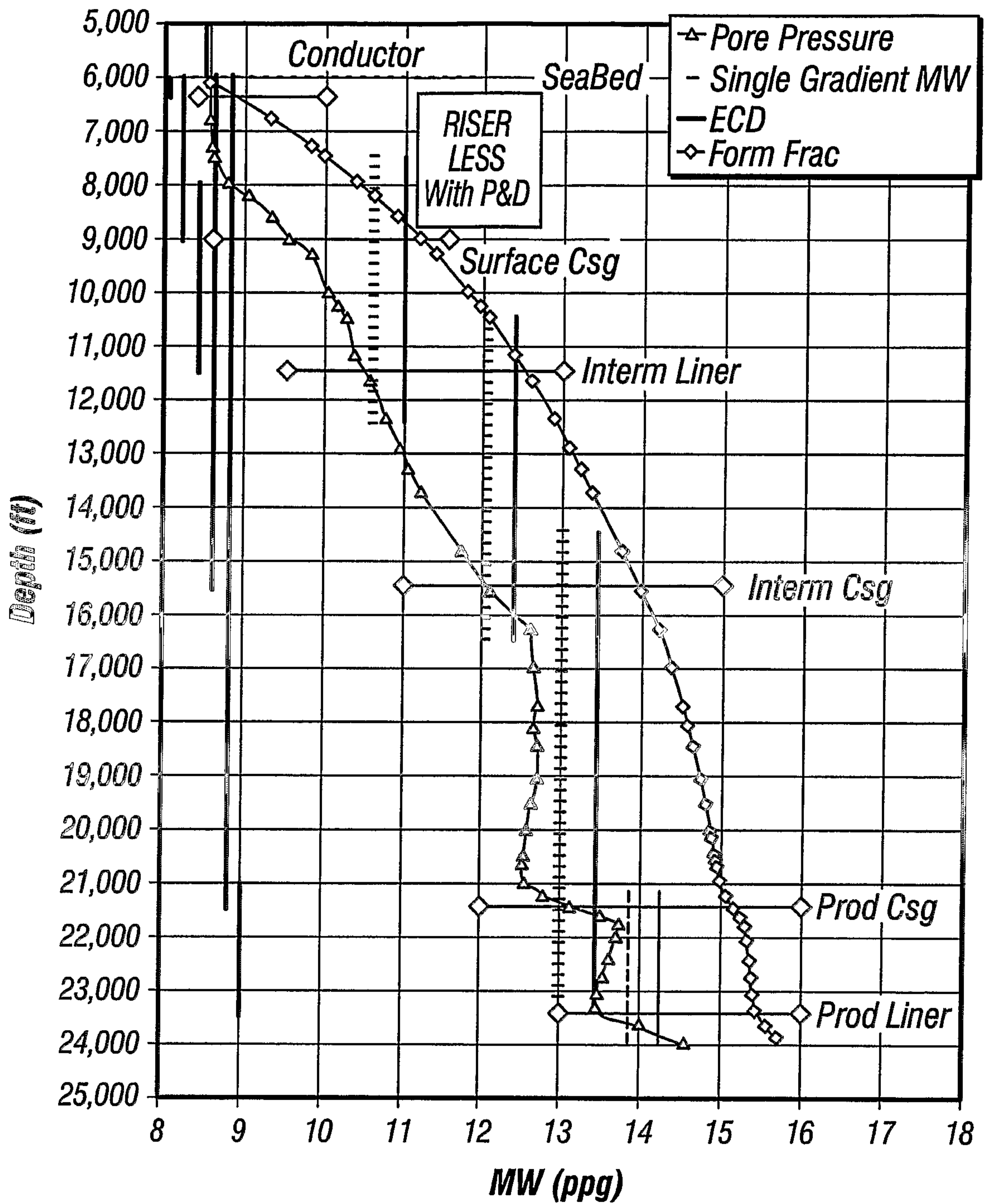

FIG. 3



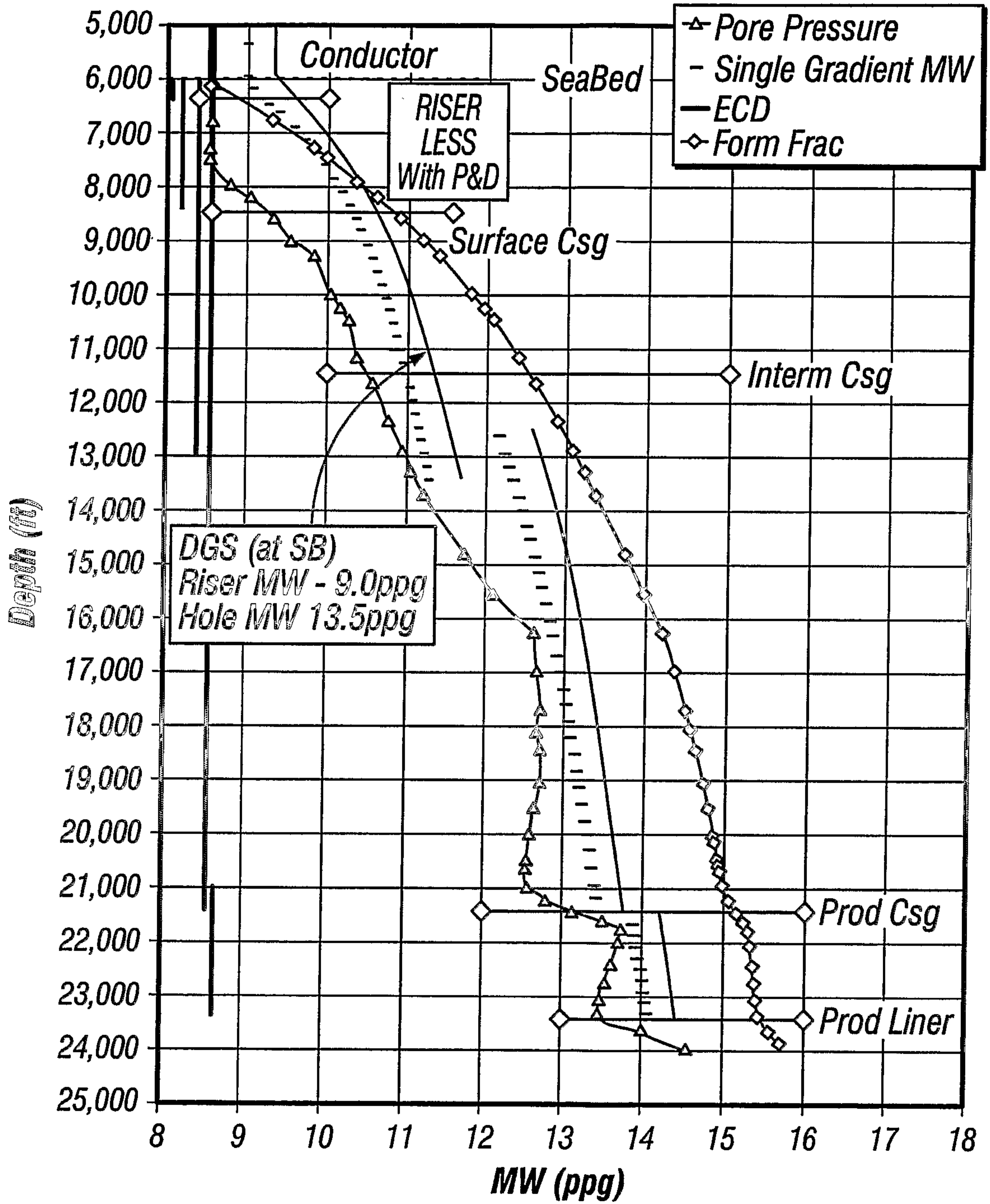

FIG. 5

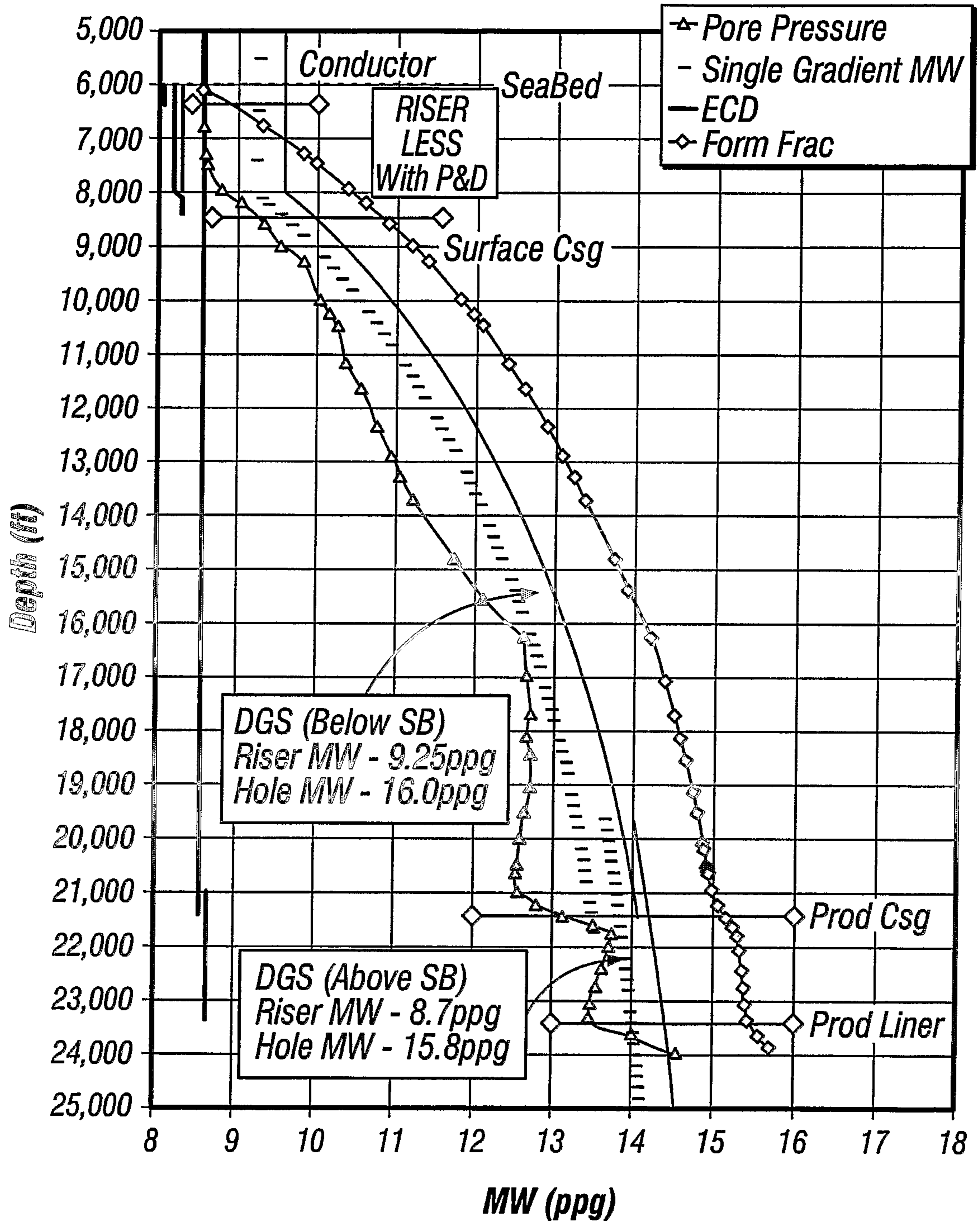

FIG. 6

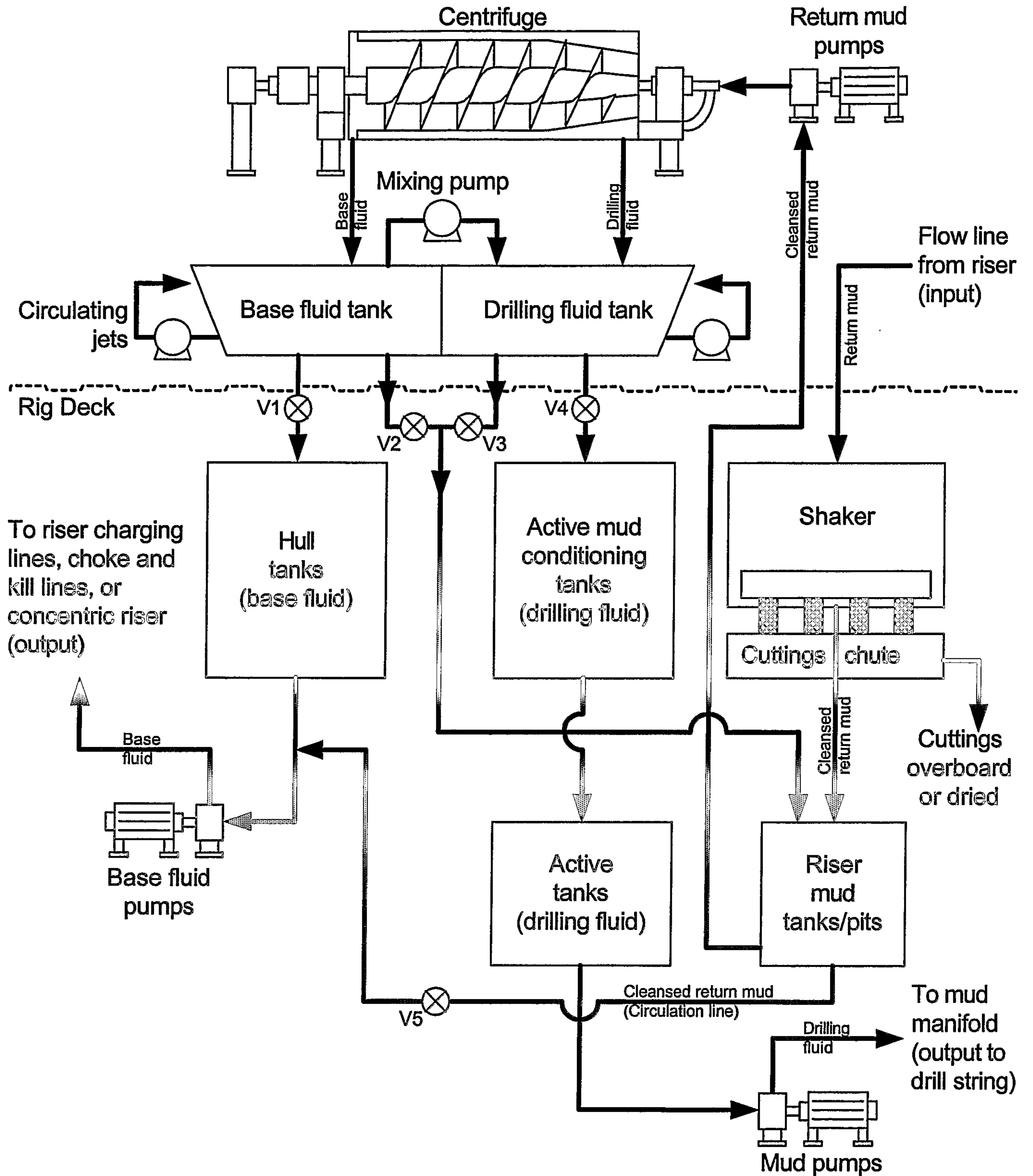

FIG. 7

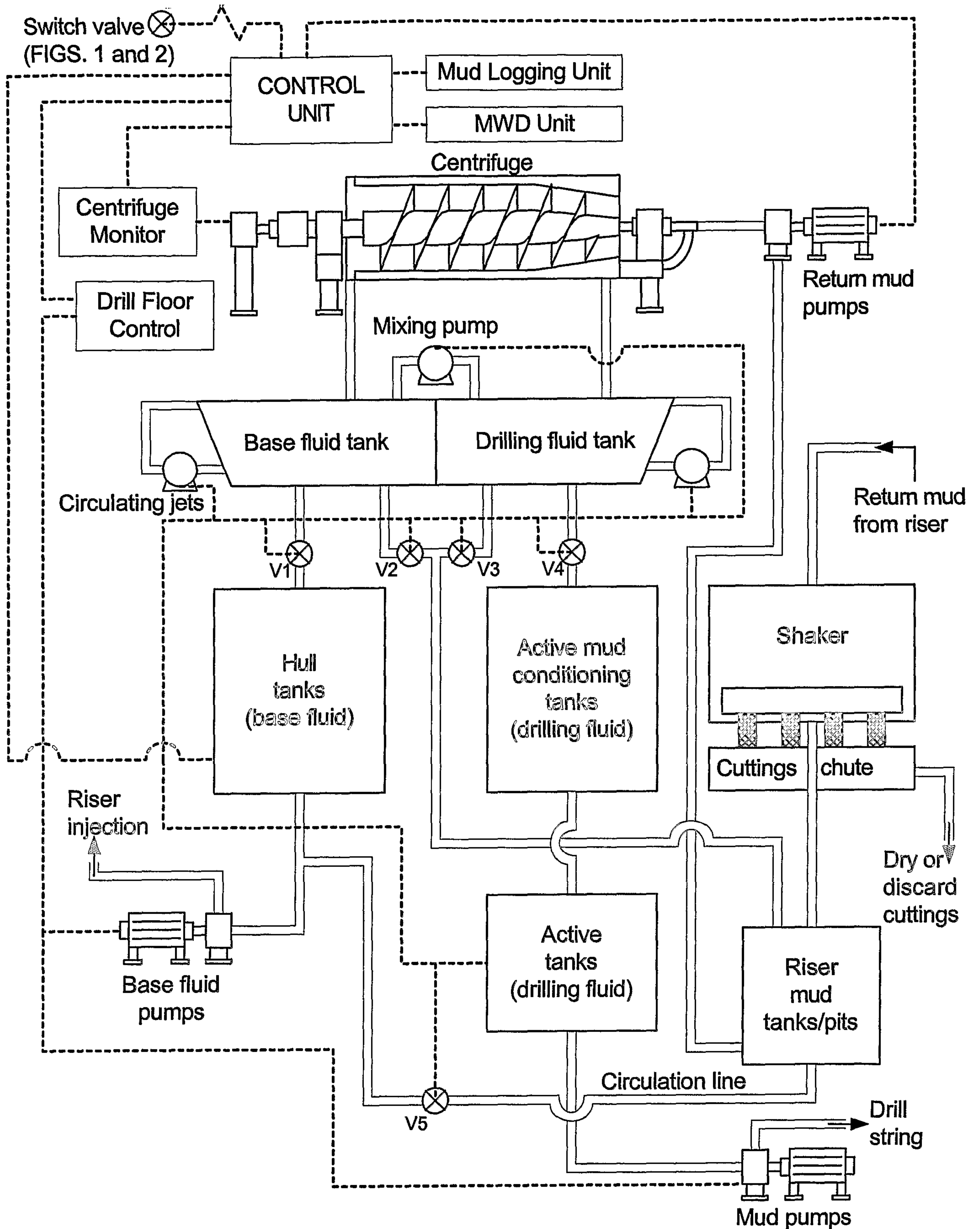

FIG. 8

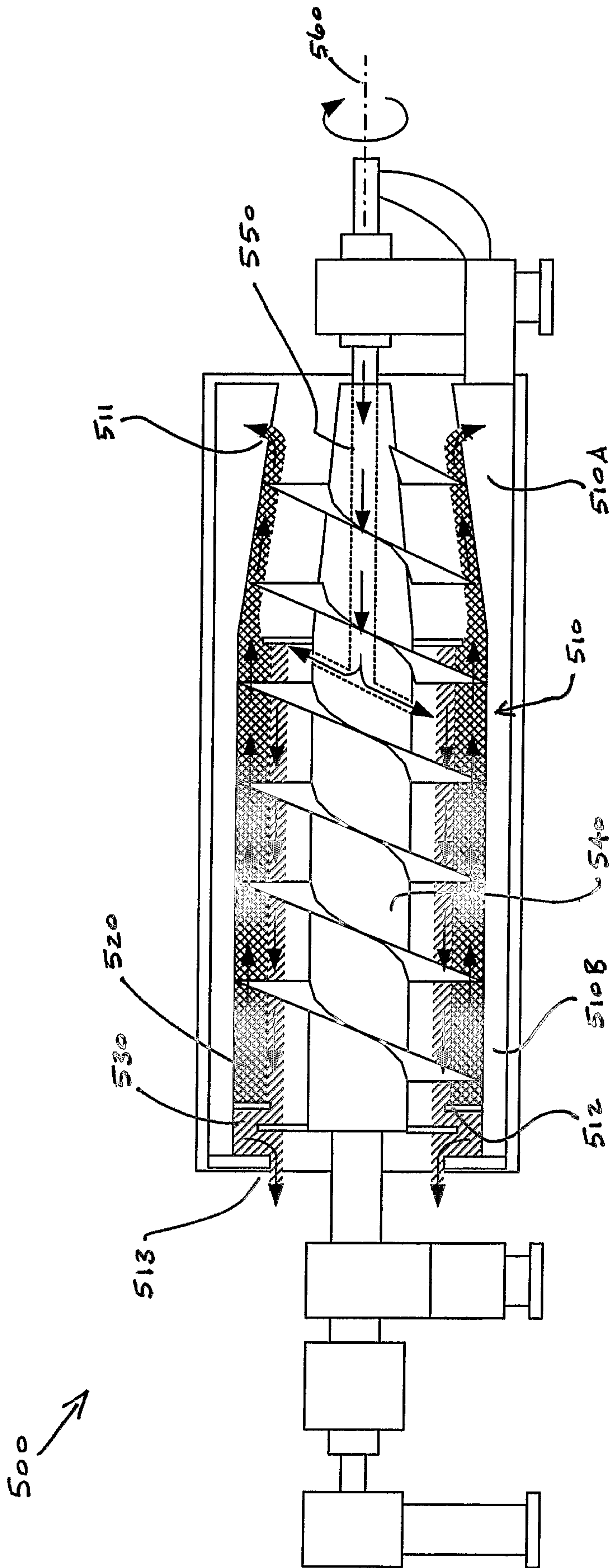

FIG. 9

10

