



- (51) International Patent Classification:  
A61F 2/44 (2006.01)
- (21) International Application Number:  
PCT/US2014/025035
- (22) International Filing Date:  
12 March 2014 (12.03.2014)
- (25) Filing Language: English
- (26) Publication Language: English
- (30) Priority Data:  
61/786,160 14 March 2013 (14.03.2013) US
- (71) Applicant: RAED M. ALI, M.D., INC. [US/US]; 5069  
Scholarship, Irvine, CA 92612 (US).
- (72) Inventor: ALI, Raed; 6 Starcatcher Circle, Newport  
Coast, CA 92657 (US).
- (74) Agent: ALTMAN, Daniel, E.; Knobbe, Martens, Olson &  
Bear, LLP, 2040 Main Street, 14th Floor, Irvine, CA  
92614 (US).

- (81) Designated States (unless otherwise indicated, for every  
kind of national protection available): AE, AG, AL, AM,  
AO, AT, AU, AZ, BA, BB, BG, BH, BN, BR, BW, BY,  
BZ, CA, CH, CL, CN, CO, CR, CU, CZ, DE, DK, DM,  
DO, DZ, EC, EE, EG, ES, FI, GB, GD, GE, GH, GM, GT,  
HN, HR, HU, ID, IL, IN, IR, IS, JP, KE, KG, KN, KP, KR,  
KZ, LA, LC, LK, LR, LS, LT, LU, LY, MA, MD, ME,  
MG, MK, MN, MW, MX, MY, MZ, NA, NG, NI, NO, NZ,  
OM, PA, PE, PG, PH, PL, PT, QA, RO, RS, RU, RW, SA,  
SC, SD, SE, SG, SK, SL, SM, ST, SV, SY, TH, TJ, TM,  
TN, TR, TT, TZ, UA, UG, US, UZ, VC, VN, ZA, ZM,  
ZW.
- (84) Designated States (unless otherwise indicated, for every  
kind of regional protection available): ARIPO (BW, GH,  
GM, KE, LR, LS, MW, MZ, NA, RW, SD, SL, SZ, TZ,  
UG, ZM, ZW), Eurasian (AM, AZ, BY, KG, KZ, RU, TJ,  
TM), European (AL, AT, BE, BG, CH, CY, CZ, DE, DK,  
EE, ES, FI, FR, GB, GR, HR, HU, IE, IS, IT, LT, LU, LV,  
MC, MK, MT, NL, NO, PL, PT, RO, RS, SE, SI, SK, SM,  
TR), OAPI (BF, BJ, CF, CG, CI, CM, GA, GN, GQ, GW,  
KM, ML, MR, NE, SN, TD, TG).

[Continued on next page]

(54) Title: LATERAL INTERBODY FUSION DEVICES, SYSTEMS AND METHODS

(57) Abstract: According to some embodiments, a method of inserting a lateral implant within an intervertebral space defined between an upper vertebral member and a lower vertebral member includes creating a lateral passage through a subject in order to provide minimally invasive access to the intervertebral space, at least partially clearing out native tissue of the subject within and/or near the intervertebral space, positioning a base plate within the intervertebral space, wherein the base plate comprise an upper base plate and a lower base plate and advancing an implant between the upper base plate and the lower base plate so that the implant is urged into the intervertebral space and the upper vertebral member is distracted relative to the lower vertebral member.

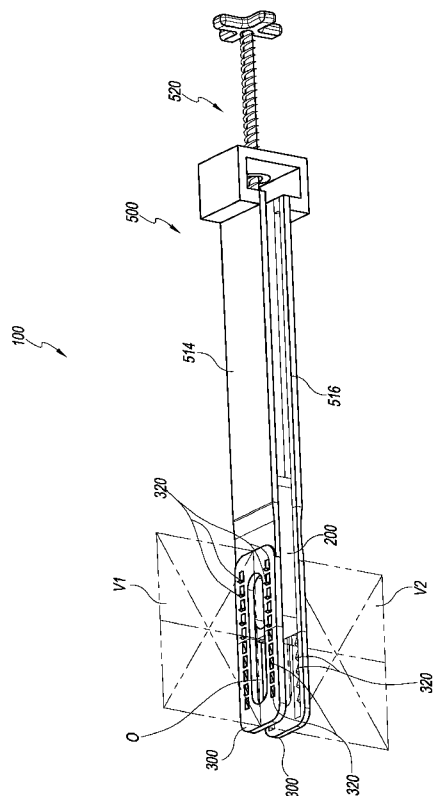

FIG. 9A



**Declarations under Rule 4.17:**

- *as to applicant's entitlement to apply for and be granted a patent (Rule 4.17(ii))*
- *as to the applicant's entitlement to claim the priority of the earlier application (Rule 4.17(iii))*

**Published:**

- *with international search report (Art. 21(3))*
- *before the expiration of the time limit for amending the claims and to be republished in the event of receipt of amendments (Rule 48.2(h))*

## LATERAL INTERBODY FUSION DEVICES, SYSTEMS AND METHODS

### Cross-Reference to Related Applications

[0001] This application claims the priority benefit under 35 U.S.C. §119(e) of U.S. Provisional Application No. 61/786,160, filed March 14, 2013, the entirety of which is hereby incorporated by reference herein.

### Background

#### Field

[0002] This application relates generally to devices, systems and methods for the treatment of the spine, and more specifically, to spinal implants and related tools, systems and methods.

#### Description of the Related Art

[0003] Surgical approaches to the intervertebral space are utilized for a variety of indications and purposes, such as, for example, biopsy (e.g., for evaluation of possible infection, other pathology, etc.), discectomy (e.g., for decompression of nerve roots, to prepare for subsequent fusion procedures, etc.), disc height restoration or deformity correction, disc replacement or repair (e.g., annular repair), discogram, gene therapy and/or other procedures or treatments.

[0004] Various approaches are currently used to access the interbody or intervertebral space of a patient's thoracic, lumbar and sacral spine. These include anterior approaches (ALIF) (e.g., open, mini-open retroperitoneal, etc.), lateral approaches (e.g., costotransversectomy, extreme lateral, etc.), posterolateral approaches (e.g., posterior lumbar interbody fusion (PLIF), transforaminal lumbar interbody fusion (TLIF), etc.) and axial approaches (e.g., axial lumbar interbody fusion). Further, many minimally invasive and percutaneous approaches rely on radiographic landmarks with or without direct view to access a targeted interbody space. In addition, many, if not all, of these currently used approaches require violation of the disc annulus to access the disc space.

[0005] Fusion surgery of the thoracic, lumbar and sacral spine is often performed for a variety of indications, including degenerative joint disease, deformity, instability and/or the like. Typically, traditional fusion approaches involve relatively large, open incisions

performed under direct vision. Minimally invasive surgical techniques and corresponding surgical implants have become more popular in an attempt to reduce morbidity and generally improve outcomes. Multiple variations of percutaneous systems (e.g., pedicle screw and rod systems, facet screw systems, etc.) have been developed. Such systems can allow for instrumentation placement with fluoroscopic guidance (e.g., using radiographically recognizable body landmarks) and/or other imaging technologies. Current fusion techniques, including those that utilize open and minimally invasive approaches, often require direct visualization. However, such techniques typically involve traversing spaces that are occupied by neural elements. Thus, these neural elements need to be retracted or otherwise moved during the execution of spinal procedures that precede implantation (e.g., annulotomy, discectomy, disc space and/or vertebral endplate preparation, etc.). Retraction of sensitive neural elements can also be required during the delivery of an implant to the spine.

[0006] These approaches typically require contact and retraction of nerve roots and/or sensitive visceral organs, blood vessels and/or other sensitive portions of the anatomy. Contact and retraction of these structures can place them at risk, thereby increasing the likelihood of complications and damage to a patient. Accordingly, a need exists for improved approaches for spinal fusion and/or access to intervertebral spaces.

#### Summary

[0007] According to some embodiments, a method of inserting an implant within an intervertebral space defined between an upper vertebral member and a lower vertebral member comprises positioning a plate system within the intervertebral space, wherein the plate system comprises an upper plate and a lower plate, and

[0008] advancing an implant between the upper plate and the lower plate so that the implant is urged into the intervertebral space, the upper plate engages the upper vertebral member, and the lower plate engages the lower vertebral member, wherein upon advancement of the implant between the upper and lower plates, the upper vertebral member is distracted relative to the lower vertebral member.

[0009] According to some embodiments, advancing an implant between the upper and lower base plates comprises using a device or tool (e.g., mechanical tool, pneumatic tool, etc.). In one embodiment, advancing the implant between the upper plate and the lower plate

comprises advancing the implant at least partially through a guiding assembly (e.g., between upper and lower members of the assembly). In one embodiment, the guiding assembly is removably secured and/or aligned with the upper and lower plates.

**[0010]** According to some embodiments, the guiding assembly comprises upper and lower guiding members or plates, wherein the upper and lower guiding members or plates are configured to removably engage corresponding portions of the upper and lower plates when the implant is advanced into the intervertebral space. In some embodiments, advancing the implant between the upper and lower plates deploys at least one engagement member or feature of at least one of the upper plate or the lower plate, wherein the at least one engagement member or feature is configured to engage at least a portion of the an adjacent vertebral member. In some embodiments, the at least one engagement member or feature comprises a tooth, spike, barb and/or the like.

**[0011]** According to some embodiments, the implant is configured to be advanced between the upper and lower plates using a rail system. In one embodiment, the rail system comprises at least one protruding member or feature on the implant and at least one corresponding groove or recess on the upper plate or lower plate, wherein the at least one protruding member or feature is configured to (e.g., slidably or otherwise) move within the at least one corresponding groove or recess on the upper plate or lower plate. In some embodiments, the rail system comprises at least one groove or recess on the implant and at least one corresponding protruding member or feature on the upper plate or lower plate, wherein the at least one protruding member or feature is configured to (e.g., slidably or otherwise) move within the at least one corresponding groove or recess.

**[0012]** According to some embodiments, the implant comprises a generally smooth outer surface. In some embodiments, the implant does not comprise any teeth or other engagement features. In some embodiments, the implant comprises PEEK, stainless steel, titanium, other metals or alloys, other polymeric materials and/or the like.

**[0013]** According to some embodiments, the upper and lower plates comprise at least one metal or alloy and/or a polymeric material (e.g., PEEK). In some embodiments, the at least one metal or alloy comprises titanium, stainless steel and/or any other medical grade metal or alloy. In some embodiments, the lower plate and/or the upper plate is bead-blasted or is otherwise at least partially roughened (e.g., along one or more surfaces that are

configured to contact and engage native vertebral tissue of the subject). In some embodiments, the lower plate and/or the upper plate comprises an ingrowth surface (e.g., along one or more surfaces that are configured to contact and engage native vertebral tissue of the subject).

**[0014]** According to some embodiments, the method further comprises securing at least one screw or other fastener through an opening of the implant (and/or an adjacent plate, washer or other member) after the implant has been properly secured within the intervertebral space. In some embodiments, the at least one screw passes through at least a portion of the upper or lower plate. In some embodiments, the at least one screw passes through at least a portion of the upper or lower vertebral member (and/or an adjacent plate, washer or other member).

**[0015]** According to some embodiments, the method further comprises creating a passage (e.g., lateral passage) through a subject in order to provide minimally invasive access to the intervertebral space. In one embodiment, the method further comprises clearing out native tissue of the subject within and/or near the intervertebral space (e.g., using one or more rasps and/or other native tissue removal tools or methods).

**[0016]** According to some embodiments, a spinal fusion system comprises a plate system configured for placement within an intervertebral space of a subject, wherein the plate system comprises an upper plate and a lower plate, an implant configured to be advanced and positioned between the upper plate and the lower plate to secure the implant within the intervertebral space, wherein, when the implant is advanced between the upper plate and the lower plate, the upper plates engages the upper vertebral member, and the lower plate engages the lower vertebral member, and wherein, upon advancement of the implant between the upper and lower plates, the upper vertebral member is distracted relative to the lower vertebral member.

**[0017]** According to some embodiments, the system additionally comprises a guiding assembly having upper and lower slides, wherein the upper slide is configured to removably couple to the upper plate, and wherein the lower slide is configured to removably couple to the lower plate. In one embodiment, the upper plate and/or the lower plate comprises at least one engagement member (e.g., tooth, spike, barb, etc.) configured to

engage a portion of the adjacent vertebral member when the implant has been advanced between the upper and lower plates.

[0018] According to some embodiments, the implant is configured to be advanced between the upper and lower plates using a rail system. In one embodiment, the rail system comprises at least one protruding member or feature on the implant and at least one corresponding groove or recess on the upper plate or lower plate, wherein the at least one protruding member or feature is configured to slidably move within the at least one corresponding groove or recess on the upper plate or lower plate. In some embodiments, the rail system comprises at least one groove or recess on the implant and at least one corresponding protruding member or feature on the upper plate or lower plate, wherein the at least one protruding member or feature is configured to slidably move within the at least one corresponding groove or recess.

[0019] According to some embodiments, the implant comprises a generally smooth outer surface. In one embodiment, the implant does not comprise any teeth or other engagement features. In some embodiments, the implant comprises PEEK, titanium and/or any other metal, alloy and/or polymeric material. In one embodiment, the upper and lower plates comprise at least one metal (e.g., titanium, stainless steel, etc.), alloy and or polymeric material (e.g., PEEK).

[0020] According to some embodiments, the system further comprises at least one screw or other fastener, the screw or fastener being configured to be secured through an opening of the implant after the implant has been properly secured within the intervertebral space. In one embodiment, the at least one screw passes through at least a portion of the upper or lower plate. In some embodiments, the screw passes through at least a portion of the upper or lower vertebral member.

[0021] According to some embodiments, a method of inserting a lateral implant within an intervertebral space defined between an upper vertebral member and a lower vertebral member includes creating a lateral passage through a subject in order to provide minimally invasive access to the intervertebral space, at least partially clearing out native tissue of the subject within and/or near the intervertebral space, positioning a base plate within the intervertebral space, wherein the base plate comprise an upper base plate and a lower base plate and advancing an implant between the upper base plate and the lower base

plate so that the implant is urged into the intervertebral space and the upper vertebral member is distracted relative to the lower vertebral member.

[0022] According to some embodiments, advancing an implant between the upper and lower base plates comprises using a mechanical device (e.g., a threaded-system using a rotatable handle to advance a rod or other actuator, manual or mechanically-assisted device, etc.). In some embodiments, the implant comprises at least one groove and at least one of the upper base plate member and the lower base plate member comprises at least one protruding feature, the at least one groove being configured to align and move relative to the at least one protruding feature. In some embodiments, the implant is delivered through the base plate using a rail or other alignment system. In some embodiments, the implant comprises at least one of PEEK, titanium and/or the like. In some embodiments, the base plate comprises titanium, stainless steel or another medically-acceptable metal or alloy.

[0023] According to some embodiments, the method further includes securing at least one screw (e.g., 1, 2, 3, 4, more than 4, etc.) through an opening of the implant after the implant has been properly secured within the intervertebral space. In one embodiment, the screw also passes through at least a portion of the upper or lower base plate member and/or the upper or lower vertebra.

[0024] The methods summarized above and set forth in further detail below describe certain actions taken by a practitioner; however, it should be understood that they can also include the instruction of those actions by another party. Thus, actions such as “advancing an implant” include “instructing advancing an implant.”

#### Brief Description of the Drawings

[0025] These and other features, aspects and advantages of the present application are described with reference to drawings of certain embodiments, which are intended to illustrate, but not to limit, the present inventions. It is to be understood that these drawings are for the purpose of illustrating the various concepts disclosed herein and may not be to scale.

[0026] FIG. 1 schematically illustrates one embodiment of a spinal implant system with the implant not positioned within the target intervertebral space;

[0027] FIG. 2 illustrates the system of FIG. 1 with the implant positioned between the base plate members and implanted within the intervertebral space;

[0028] FIGS. 3A and 3B illustrate various views of a base plate of an implant system according to one embodiment;

[0029] FIG. 4 illustrates a side view of a spinal implant system according to one embodiment;

[0030] FIGS. 5A-5C illustrate various views of one embodiment of a base plate for use in a spinal implant system;

[0031] FIGS. 6A and 6B illustrate various views of one embodiment of an implant configured for use in a spinal implant system;

[0032] FIG. 7A illustrates one embodiment of a base plate configured for use in a spinal implant system;

[0033] FIG. 7B illustrates one embodiment of an implant configured to be used together with the base plate of FIG. 7A;

[0034] FIGS. 8A-8C illustrate various time-sequential side views during a spinal implant procedure according to one embodiment;

[0035] FIGS. 9A-9D illustrate different views of a fusion system according to one embodiment;

[0036] FIGS. 10A and 10B illustrate different views of one embodiment of an implant configured for use with a spinal fusion system;

[0037] FIG. 11 illustrates a partial cross-sectional view of an implant positioned within a guiding assembly and upper and lower plates, according to one embodiment;

[0038] FIG. 12 illustrates a perspective view of one embodiment of an implant secured between upper and lower plates of a fusion system;

[0039] FIG. 13 illustrates a perspective view of one embodiment of an implant secured between upper and lower plates of a fusion system reinforced by two screws; and

[0040] FIG. 14 illustrates a schematic top view of a portion of a guiding assembly and a corresponding plate configured for use with a spinal fusion system according to one embodiment.

#### Detailed Description

[0041] A variety of examples described below illustrate various configurations that may be employed to achieve desired improvements. The particular embodiments and

examples are only illustrative and not intended in any way to restrict the general concepts presented herein and the various aspects and features of such concepts.

[0042] According to some embodiments, the present application discloses various devices, systems and methods for accessing the intervertebral or interbody space of a patient's spine and/or performing certain procedures related to spinal fusion using minimally invasive surgery (MIS) techniques. As discussed in greater detail herein, the intervertebral or interbody space of the targeted portion of the patient's spine is accessed and/or treated minimally invasively using, at least in some embodiments, a lateral approach. The terms "intervertebral space" and "interbody space" are used interchangeably herein, and generally refer to the space, gap or region between adjacent vertebral members. By way of example, as illustrated in FIG. 1, the intervertebral space 14 between adjacent vertebrae 10, 12 can be accessed using one or more lateral openings or passages created laterally through the subject's anatomy (e.g., using one or more access device, such as, retractors, dilators, etc.). In some embodiments, such openings or passages are created, accessed and/or otherwise use using MIS techniques or procedures. The various devices, systems and methods disclosed herein, and variations thereof can be applied to any type of spinal implant, including, but not limited to, a lateral interbody fusion implant, a transforaminal lumbar interbody fusion (TLIF) implant, an oblique TLIF implant, a posterior lumbar interbody fusion (PLIF) implant, an anterior lumbar interbody fusion (ALIF) implant and/or the like. Accordingly, the various embodiments disclosed herein can be in a variety of MIS or non-MIS approaches, including, without limitation, lateral, TLIF, posterior, ALIF and/or the like.

[0043] FIG. 1 schematically illustrates one embodiment of a spinal fusion or stabilization system 50. As shown, the system 50 can include upper and lower plates (e.g., endplate members) 300 or other members that are positioned along the endplates of the upper and lower vertebral members 10, 12. In some embodiments, the plates 300 generally extend across the entire or substantially the entire width of the vertebrae 10, 12. In some embodiments, the plates 300 are the same length or substantially the same length as the spinal implant 200 that will be delivered between the plates 300 and into the intervertebral space 14. For example, the plates 300 and/or the implant 200 can be approximately 40 to 60 mm long (e.g., 40, 45, 50, 55, 60 mm, lengths between the foregoing ranges, etc.). In other

embodiments, however, the length of the implant is greater than 60 mm or less than 40 mm, as desired or required.

[0044] According to some embodiments, the upper and lower plates comprise at least one metal or alloy and/or a polymeric material (e.g., PEEK). In some embodiments, the at least one metal or alloy comprises titanium, stainless steel and/or any other medical grade metal or alloy. In some embodiments, the lower plate and/or the upper plate is bead-blasted or is otherwise at least partially roughened (e.g., along one or more surfaces that are configured to contact and engage native vertebral tissue of the subject). In some embodiments, the lower plate and/or the upper plate comprises an ingrowth surface (e.g., along one or more surfaces that are configured to contact and engage native vertebral tissue of the subject). In some arrangements, such a configuration can assist to prevent movement between the plate and the vertebral body.

[0045] In some embodiments, as illustrated in FIG. 9A, each of the upper and lower plates 300 comprises at least one central opening O that can at least partially align with and provide access to (e.g., from a space generally between the upper and lower plates) to native tissue of the adjacent vertebral members V1, V2 of the subject.

[0046] In some embodiments, once the plates (e.g., endplate members) 300 have been properly positioned within the target intervertebral space 14, the implant 200 can be delivered (e.g., laterally) between the upper and lower plates or other members 300. The delivery of the implant 200 between the plates 300 can be performed with or without the use of a mechanical delivery tool (e.g., by using a threaded delivery device or other device providing for mechanical advantage, etc.). Regardless of the exact manner in which the implant 200 is advanced into the intervertebral space 14 between the upper and lower plates 300, the upper and lower plates 300 can provide one or more advantages or benefits. For example, the use of the plates 300 can help distribute forces and moments along a larger surface area. This is generally illustrated by the schematic force distribution diagram F in FIG. 2. Accordingly, the likelihood of potentially damaging localized forces, moments and/or other stresses on a particular portion or area of the adjacent vertebrae 10, 12 can be reduced or eliminated. The risk of damage to bone and/or other native tissues to the subject during a fusion procedure can be further reduced by advancing the implant 200, and thus separating the upper and lower plates 300 in a more predictable, gentler manner (e.g., as

opposed to traditional methods of using great force to position an implant within a target intervertebral space).

[0047] Further, in some embodiments, the use of the upper and lower plates 300 can facilitate the delivery of the implant 200 within the target interbody space with greater ease and less resistance. As a result, the endplates and other portions of the adjacent vertebrae 10, 12 can be protected against shearing, fractures and/or other damage. This can be especially important when the implant 100 causes distraction (e.g., separation or opening) of a collapsed or partially collapsed interbody space 14, as represented by the arrows 16 in FIG. 2.

[0048] As discussed herein, one or both sides of the upper and/or lower plates can include spikes, teeth, other protruding members and/or other engagement features. For example, if such engagement features are positioned along the top of the upper plate or the bottom of the lower plate, the engagement features can be advanced into the adjacent endplate(s) as the implant 200 is moved between the plates 300. This can help secure the plates to the adjacent vertebrae 10, 12. In some embodiments, engagement features can be positioned along the opposite surfaces of the plates (e.g., along the bottom of the upper plate and/or along the top of the lower plate). Such engagement features can help prevent or reduce the likelihood of relative movement between the implant 200 and the plates 300 following implantation. In other embodiments, as discussed in greater detail herein with reference to, e.g., FIGS. 9A to 12, the implant 200 and the adjacent surfaces of the upper and lower plates 300 can include recesses, protrusions, other components of a "rail" system and/or any other feature to help maintain a particular orientation between the plates and the implant during use and/or after implantation, to help prevent or reduce the likelihood of any undesirable relative movement between the plates and the implant during use and/or after implantation and/or the like. Thus, the plates and/or the implant can include one or more other features, such as, for example, rails or guiding members (e.g., to assist in moving the implant more easily and more predictably between the plates), tabs or other portions configured to receive one or more screws or other fasteners (e.g., to further secure the system 100 to the spine after delivery into the intervertebral space) and/or the like.

[0049] FIGS. 3A and 3B illustrate different views of one embodiment of upper and lower plates (e.g., base plates or endplate members) 300 configured for use in a spinal

fusion system. As shown, the base plates 300 can include upper and lower plates 310, 314. The base plates 300 can be shaped, sized and configured to span across an entire width of the subject's vertebrae 10, 12. As discussed herein, the upper and/or lower plates can include one or more openings to provide access to the adjacent native vertebral surfaces of the subject after implantation. In some embodiments, the base plates 300 extend beyond one or more side of the vertebral periphery or do not extend to the lateral edge of the vertebrae (e.g., are short by a certain clearance distance from one or more lateral edges of the vertebrae). In some embodiments, where the plates 300 extend beyond a perimeter of the upper and/or lower vertebrae, a portion of the plate 300 can be configured to be removed or manipulated after implantation. For example, in some embodiments, in such a configuration, a protruding portion of the plate can be folded or bent (e.g., either upwardly or downwardly) to move the folded or bent portion either toward or away from the intervertebral space. In some embodiments, such a bent or folded portion can include one or more openings or other holes that can be used to place a bone screw or other fastener therethrough (e.g., to secure that portion of the plate to an adjacent vertebral member, to another bent or folded plate used in a fusion system, to a separate washer or other plate member and/or the like).

**[0050]** As shown in FIG. 3A, the plate members 310, 314 can include one or more protruding members (e.g., teeth, rails, other engagement members or features, etc.) 320 that extend toward each other (e.g., toward the intervertebral space). Such protruding members can be fixed or movable. For example, in some embodiments, the protruding members 320 are deployable (e.g., before, during or after advancement of an implant between the base plates 300). In other embodiments, plate members 300 can include teeth, protruding members or other engagement features or devices along their opposite surfaces (e.g., along the top of the upper plate, along the bottom of the lower plate, etc.), either in lieu of or in addition to having inwardly-directed protruding members. As discussed in greater detail herein, outwardly-projecting protruding members 320 on the plates (e.g., FIG. 9A) can help secure the plates to the adjacent surfaces of the upper and lower vertebral members of the subject being treated. This can advantageously provide one or more clinical benefits, such as, for example, the preservation of long-term implantation (e.g., reducing the likelihood of dislodgement or movements of the implant system within the target intervertebral space following implantation).

[0051] With continued reference to FIG. 3A, a system can include a guiding assembly 500 that can be strategically positioned along one of the lateral ends of the targeted intervertebral space. The guiding assembly 500 can include an alignment device 510 that may comprise one or more alignment components 514, 516. Regardless of its exact configuration and design, the alignment device 510 can advantageously permit a surgeon or other practitioner to accurately position the guiding assembly 500 for the subsequent delivery of an implant therethrough and between the base plates 300. As discussed in greater detail herein, the guiding assembly 500 can include upper and lower alignment members or slide members 514, 516, which are generally aligned with the upper and lower plates 300. In some embodiments, each alignment member 514, 516 can be configured to removably attach to the corresponding plate 300 to help advance and position the plates 300 within the targeted intervertebral space (e.g., minimally invasively). In some embodiments, the distal ends of the alignment members or slides 514, 516 can be configured to be slidably received within slots, recesses or other portions of the plates 300. Thus, the guiding assembly 500 can be temporarily coupled to the plates when the plates are being advanced into the intervertebral space and when the implant is subsequently delivered between the plates (e.g., as discussed in greater detail below). However, in some embodiments, once the implant 200 has been properly advanced between the plates and the implant system has been adequately secured between the adjacent vertebrae, the alignment members or slides 514, 516 can be easily retracted (e.g., rearwardly or proximally) relative to the plates and implant for removal from the subject's anatomy and completion of the fusion procedure.

[0052] With continued reference to FIG. 3A, the alignment members or components 514, 516 and/or one or more other portions or components of the assembly can include a flange or other abutment or securement portion 518. Such a flange 518 can be fixedly or movably positioned along the adjacent vertebrae 10, 12 of the subject to ensure proper alignment into the targeted intervertebral space. In other arrangements, as noted herein, the alignment members and other components of the guiding assembly are configured to completely decouple from the plates and the implant after implant has been properly delivered into the target intervertebral space.

[0053] As illustrated in FIG. 4, an implant 200 can be delivered between the plates 300 and into the intervertebral space using a mechanical advancement device.

Therefore, in some embodiments, the guiding assembly 500 can advantageously comprise a mechanical advancement device or feature. For example, in FIG. 4, the guiding assembly comprises a threaded delivery portion that is configured to advance an implant 200 between the base plate members 310, 314 by turning a rotatable handle or other advancement tool. As a user rotates the handle 520, a rod 522 or other actuator is moved forwardly (e.g., distally) in the direction of the implant 200. The implant 200 can be directly or indirectly coupled to the actuator 522 via one or more coupling or other detachable connections 526, as desired or required. As the rod is advanced distally, the implant (e.g., lateral cage) can be guided between the base plate members 310, 314 and into the intervertebral space. Consequently, the base plate members 310, 314 separate and are urged toward the adjacent endplates of the vertebrae. In some embodiments, as illustrated schematically in FIG. 4, the implant can include a taper (e.g., bullet design) along its distal end to facilitate initial entry and subsequent distraction and separation of the base plate 300.

**[0054]** In other embodiments, one or more other devices can be used to help advance the implant between the plates. For example, a pneumatic tool (e.g., air or liquid driven tool) can be used to apply the required force on the implant to move it into position. Any other type of user-assisting device or system can be used to help advance the implant between the plates, such as, for example, other types of mechanical devices, electromechanical devices, motorized devices, pumps and/or the like.

**[0055]** With continued reference to FIG. 4, the guiding assembly 500 can include one or more structures 510 that help ensure that the implant stays within the guiding assembly 500 and maintains its alignment with the intervertebral space during advancement between the plates. Such structure 510 can, for example, help reduce any deflection or misdirection of the implant's leading end during distal delivery to the intervertebral space, especially when relatively high forces are being exerted on the implant (e.g., that may otherwise cause the implant to move out of alignment with the base plates). In some embodiments, the implant 200, the base plates 300 and/or any other portion of the system can include rails or other alignment features that further help maintain a proper alignment of the implant during advancement between a subject's vertebrae. As discussed in greater detail herein, the guiding assembly can include alignment members (e.g., slides) 514, 516 that removably secure to the plates 300 and provide a reliable and predictable path for

advancement of the implant within the intervertebral space. In some embodiments, such slides 514, 516 can be subsequently removed and decoupled or separated (e.g., slidably, mechanically, etc.) from the plates 300.

**[0056]** FIGS. 5A-5C illustrate various views of a different embodiment of a system comprising base plates 300 for receiving a spinal implant. As shown, an alignment device 510' can be positioned relative to one or more of the adjacent vertebrae 10, 12 and subsequently secured thereto using additional fasteners or other connection devices or methods. For example, one or more screws S or other fasteners can be used to secure one or more portions of the alignment device to the upper and/or lower vertebral members of the subject. In some embodiments, the alignment devices 510' comprise one or more flanges or plates P through which the screws S or other fasteners can be placed. Once the alignment device 510' has been secured to the subject, the implant can be delivered between the base plate members 310, 314. The alignment device 510', base plate 300 and/or other portions of the system can be left in place after the implant has been secured between the subject's vertebrae. In other embodiments, however, one or more components of the system (e.g., base plate 300, screws, etc.) can be left in place after implantation, and in some instances, may help reinforce or otherwise benefit the treated area.

**[0057]** One embodiment of an implant 200 that can be used with the spinal fusion systems disclosed herein is illustrated in FIGS. 6A and 6B. As best shown in the top view of FIG. 6B, the implant 200 can include one or more open regions or chambers 210 for holding a grafting material. In addition, the implant can include one or more grooves 220 or other recesses along its anterior and/or posterior walls. In some embodiments, such grooves 220 or other features can align and mate with corresponding rails, protrusions or features of the base plate 300. Accordingly, the grooves, rails and/or other features can help safely, accurately and predictably move the implant 200 into the target intervertebral space (e.g., between adjacent base plate members). In other embodiments, however, the rail system between the implant 200 and the adjacent plates 300 can be reversed. For example, as illustrated in the embodiments of FIGS. 9A to 16, the implant can include one or more protruding or raised portions that generally align and correspond to grooves or recesses along the adjacent surfaces of the plates 300. Regardless of the exact orientation and design of the rail system,

such a system can help ensure that an implant is accurately and safely delivered to a target intervertebral space.

[0058] In some embodiments, the implants disclosed herein comprise PEEK, titanium or other acceptable materials. For example, in some embodiments, the implant 200 comprises a metal edge plate or other surface or feature 226 through which one or more screws (not shown in FIGS. 6A and 6B) can be subsequently delivered to secure the implant 200 to one or more of the subject's vertebrae. In some arrangements, the plate 226, which can be positioned along the proximal end of the implant 200, comprises titanium or other acceptable metal or alloy and/or other rigid or semi-rigid material.

[0059] FIG. 7A illustrates a side view of one embodiment of a base plate 300 comprising upper and lower plate members 310, 314. As shown, the base plate members 310, 314 can include one or more protruding members 320. Such protruding members 320 can include tabs, bumps, spikes, teeth, grasping members, engagement members, other sharp, smooth and/or rounded features or members and/or the like. In some embodiments, the protruding members 310, 314 can be fixed (e.g., non-movable, non-deployable, etc.) and/or movable (e.g., selectively retractable, deployable, etc.). For example, in some embodiments, the protruding members 320 of the upper and/or lower plate members 310, 314 are deployable using a mechanical connection, a temperature change and/or using some other mechanism of action, device or method. In some embodiments, such protruding members 320 can help engage the plates 300 to the implant 200. In other embodiments, however, the protruding members 320 can be configured to reverse their orientation (e.g., in a direction away from the interior of the intervertebral space or toward the adjacent vertebral member) when the implant is advanced over the protruding members during implantation. Therefore, in some embodiments, as the implant is advanced between the plates 300, the protruding members 320 can deform or otherwise change orientation so as to engage the upper and lower vertebral members. This can provide positive engagement of the plates into the adjacent vertebrae, which may, in some circumstances, result in a more secure implantation of the system within the subject.

[0060] FIG. 7B illustrates a top view of one embodiment of an implant 200 that is configured to be used with the base plate 300 of FIG. 7A. Specifically, as shown, the implant 200 can include one or more grooves, holes, recesses or other openings 240 that are

shaped, sized and otherwise configured to receive corresponding protruding members 320 of the base plate 300. As discussed in greater detail herein, in other arrangements (e.g., FIG. 9A), an implant 200 can include one or more protruding members or features that are sized, shaped and otherwise configured to engage and move within grooves or corresponding recesses of the adjacent plates 300.

**[0061]** With continued reference to FIG. 7B, the protruding members 320' of the base plate 300 can include a curved leading edge to permit the groove 240 of the implant 200 to only temporarily engage the member 320' as the implant is advanced into the target intervertebral space. Thus, the protruding members can sequentially engage and disengage a groove on the implant (e.g., in a ratcheting manner). In some embodiments, the implant can only be permitted to be advanced in one direction (e.g., distally). Such an embodiment can be helpful when using base plates 300 that have fixed protruding members 320. In embodiments comprising deployable protruding members, the need for such ratcheting system (e.g., that permits movement in at least one direction) may not be needed, as the protruding members 320 can be selectively deployed only when the implant is properly positioned between the base plate members.

**[0062]** In some embodiments, the use of protruding members and corresponding grooves or other recesses can help with guiding an implant 200 between adjacent base plate members (e.g. during delivery). Such embodiments can also assist in securely maintaining the implant in its implanted position following the delivery of the implant in the target intervertebral space.

**[0063]** As illustrated schematically in FIGS. 8A-8C, a lateral implant device in accordance with the various embodiments disclosed herein, can be delivered to the target intervertebral space minimally invasively (e.g., through one or more tissue dilators, cannulas or other openings). As discussed in greater detail herein, once the plates 300 have been properly positioned between the subject's vertebrae 10, 12, a guiding assembly 500 can be positioned through a dilator or other access device and in general alignment with the targeted intervertebral space. The implant can be advanced using a mechanical device (as illustrated in FIG. 8A), manually and/or using some other method or device. Further, the implant and base plate can include one or more features or members (e.g., rails, grooves, etc.) to assist in accurately moving the implant in the desired anatomical location of the subject's spine.

Once the implant has been advanced between the base plate members 310, 314 and properly within the intervertebral space, the guiding assembly 500 can be removed.

[0064] With reference to FIG. 8B, in some embodiments, a screwdriver or other mechanical device 600 can be delivered through a dilator, cannula or other access device C to engage and advance one or more screws S or other fasteners through corresponding openings along the proximal end of the implant 200. In some embodiments, the use of such fasteners can assist with maintaining the position of the implant 200 relative to the subject's spine following implantation, as shown in FIG. 8C. The screws S can be routed through the implant, the base plate and/or the vertebra, as desired or required. However, in other embodiments, the use of screws S or other fasteners is not needed or required to maintain the implanted implant between the base plate members and the adjacent vertebrae. In some embodiments, a total of four fixation screws are positioned through the proximal end of the implanted implant (e.g., two above and two below). In some embodiments, the screws or other fasteners can be passed through openings of one or more plates or washers that at least partially cover or otherwise shield the intervertebral space, provide additional structural support and/or provide one or more other benefits or advantages. In other embodiments, more or fewer screws or other fasteners can be used, as desired or required.

[0065] In order to remove disk material, cartilage, endplate or other vertebral tissue and/or native tissue of a subject during an implantation procedure, a surgeon or other practitioner can use any of the rasping or other tissue cutting devices and methods disclosed in U.S. Patent Application No. 13/422,816, titled TRANSPEDICULAR ACCESS TO INTERVERTEBRAL SPACES AND RELATED SPINAL FUSION SYSTEMS AND METHODS, filed March 16, 2012 and published as U.S. Publ. No. 2012/0265250 on October 18, 2012, and U.S. Provisional Patent Application No. 61/783,839, titled DEVICES AND METHODS FOR TRANSPEDICULAR STABILIZATION OF THE SPINE and filed on March 14, 2013, the entireties of both of which are hereby incorporated by reference herein and made a part of the present application.

[0066] FIGS. 9A-9D illustrate different views of another embodiment of a spinal fusion system 100. As discussed above with reference to other arrangements, the system 100 can include upper and lower plates 300 that are sized, shaped and otherwise configured to be positioned between the adjacent vertebral members V1, V2 where fusion is targeted. The

system 100 further comprises a guiding assembly 500. In some embodiments, as discussed above, the alignment members (e.g., slides) 514, 516 of the guiding assembly 500 are configured to releasably secure or otherwise temporarily engage to or with the plates 300. Accordingly, the plate-slide assembly can be placed within the subject and advanced to the target intervertebral space. For example, in some embodiments, one or more distal portions of the alignment members or slides 514, 516 can releasably attach to and/or slide within adjacent portion(s) of the plates 300. In other embodiments, such as the system 100A illustrated in FIG. 14, one or both of the slides 514A, 516A comprise an extension portion 518A that extends into the targeted intervertebral space and provides a surface over which the implant can move when the implant is advanced in the vicinity of the vertebral members. The use of such extension portion 518A can help maintain the graft material within the interior chambers of the implant during advancement to the intervertebral space. Accordingly, the use of extension portions 518A or similar members or features can be advantageously incorporated into any implant system embodiments disclosed herein or equivalents thereof.

[0067] With continued reference to FIGS. 9A-9D, the system 100 can comprise a delivery device or feature 520 that can facilitate the surgeon or other practitioner with the advancement of the implant 200 through the guiding assembly and into the intervertebral space (e.g., between the plates 300). In some embodiments, the implant 200 is initially inserted at or near the proximal end of the guiding assembly 500, generally between the alignment members or slides 514, 516. Then, once the surgeon has advanced the guiding assembly 500, and in some configurations, the plates 300 and the implant 200 to which the assembly 500 is engaged, through the subject's anatomy (e.g., through an access device), the surgeon can begin to move the implant distally by manipulating the handle or other portion of the guiding assembly.

[0068] For example, with reference to the side view of FIG. 9B, by turning the handle 522 of the guiding assembly 500, the threaded rod 526 can move relative to a housing 528. Such manipulation of the handle 522 can result in moving the distal end 524 of the rod 526 forwardly (e.g., distally) so as to engage the implant 200 positioned between the slides 514, 516 and exert a force on the implant 200. In some embodiments, the distal end 524 of

the rod comprises a coupling or other blunt member or feature that can help avoid damage to the adjacent portion of the implant 200 during the advancement process.

[0069] As illustrated in FIG. 9A, as the implant is advanced distally within the interior of the guiding assembly 500 (e.g., between the upper and lower slides or alignment members 514, 516), the distal end of the implant 200 will reach the proximal end of the plates 300 that have been positioned within the intervertebral space. With continued advancement of the implant 200 in the distal direction (e.g., as schematically represented by arrow 50 in FIG. 9C), the implant 200 will move between the upper and lower plates 300, causing the plates 300 to separate apart from each other, in certain arrangements. In some configurations, the implant 200 is moved far enough distally between plates 200 so that it spans across an entire length or substantially an entire length of the plates 300.

[0070] FIGS. 10A and 10B illustrate one embodiment of an implant 200 that is configured to be used with one or more of the fusion systems disclosed herein, including the system 100 of FIGS. 9A-9D. As shown, the implant 200 can include one or more internal chambers 210. Such chambers 210 can be sized, shaped and otherwise configured to be at least partially filled with graft material (not shown) before the implant 200 is advanced between the plates 300. As noted above, the implant 200 can comprise one or more materials, such as, for example, PEEK, titanium, other metals or alloys, other polymeric materials and/or the like.

[0071] With continued reference to FIGS. 10A and 10B, the implant 200 can include one or more protrusions, ridges or similar members or features 220 that extend at least partially along one or more surfaces of the implant 200. In some embodiments, such protrusions 220 can be sized, shaped and otherwise configured to be moved relative to corresponding grooves or recesses of the upper and lower plates 300 and/or the upper and lower slides or alignment members 514, 516 of the guiding assembly 500. For example, as shown in the embodiment of FIG. 11, the upper plate and/or the lower plate 300 can include one or more grooves or recesses 320 that are configured to receive the protrusions 220 of the implant 200 when the implant is properly positioned within the guiding assembly 500 and between the plates 300. Although not illustrated in the view of FIG. 11, the grooves or recesses 320 can extend proximal to the plates 300 and be present, either continuously or intermittently along at least a portion of the slides 514, 516 of the guiding assembly 500.

Thus, the implant 200 can be predictably moved between the slides 514, 516 and the plates 300 to properly, safely and securely position the implant 200 within a targeted intervertebral space.

**[0072]** In the embodiments illustrated herein, the guiding assembly 500 and the plates 300 are generally straight, and the path that the implant follows through the guiding assembly 500 is generally linear. However, in other embodiments, the grooves or recesses of the guiding assembly and/or the plates (and thus, the corresponding protruding members or features of the implant 200), or vice versa, can be at least partially curved, so that the implant is moved along a non-linear pathway. In some embodiments, the non-linear pathway can comprise a continuous curve (e.g., with a constant or variable diameter along the length of the curve). However, in other arrangements, the curve or turn is more abrupt (e.g., piecemeal turn or short radius turn) so as to avoid a longer, sweeping turning radius. Such embodiments can be helpful with certain MIS approaches where an implant needs to be maneuvered more carefully and precisely around sensitive nerve structures, such as, for example, in a TLIF procedure.

**[0073]** In the embodiments of a “rail” system illustrated in FIGS. 10A, 10B and 11 herein, and discussed in greater detail above, the implant comprises generally smooth outer surfaces (e.g., does not comprises teeth or other engagement features). Since the implant will not directly contact or engage the adjacent surfaces of the vertebral members, the need for teeth, other protruding members and/or other roughened surface features may not be necessary. This can advantageously simplify the design, manufacturability, cost and other aspects of the implant.

**[0074]** In the illustrated embodiments, the implant includes generally rounded protruding members or features 220 along both of its lateral ends and along both its upper and lower surfaces. Further, the protruding features 220 are generally continuous along an entire length of the implant 200. However, in other embodiments, the implant 200 can include more or fewer protruding features 220. The protruding features 220 can include any desired cross-sectional shape or configuration (e.g., rounded, circular, oval, rectangular, triangular, other polygonal, irregular, etc.), as desired or required. Further, the protruding features 220 can extend only partially or intermittently along one or both surfaces of the implant 200. Thus, the total number of protruding members 220 (e.g., and thus,

corresponding grooves or recesses in the plates 300 and guiding assembly 500) can be less or more than four (e.g., 1, 2, 3, 4, 5, 6, 7, 8, 9, 10, more than 10, etc.), as desired or required. For example, in some arrangements, the protruding members 220 are included only the top or the bottom of the implant 200.

[0075] According to some embodiments, as illustrated in FIG. 11, the grooves or recesses 320 of the plates 300 can include one or more deployable teeth, spikes or other engagement features 322. For example, in one embodiment, the teeth or other features 322 are configured to be pushed through the bottom of the corresponding groove or recess 320, at least partially, when the protruding member or feature 220 of the implant 200 is moved over such teeth or features 322. Thus, the teeth, spikes or other engagement features 322 can be sequentially deployed away from the implant and toward the adjacent vertebral member. In some embodiments, the teeth or other engagement features 322 are deployed within the native tissue of the vertebral member to help secure the plates within the target intervertebral space during and after implantation. One schematic embodiment of an implant 200 that has passed within upper and lower plates 300 and has caused a number of teeth, spikes or other engagement features 322 to deploy away from the implant 200 is illustrated in FIG. 12.

[0076] As discussed in greater detail herein, after the implant 200 has been properly positioned between the plates 300 of the system, one or more screws or other fasteners can be used to further strengthen and reinforce the system. For example, as illustrated in FIG. 13, upper and lower screws S can be positioned through one or both of the plates 300 and/or the implant 200. Such screws can be advanced through one or more cortical structures of the adjacent vertebral members of the subject to provide additional strength and support to the fusion system. In some embodiments, one or more washers, plates or other rigid or semi-rigid members P can also be used in conjunction with the screws or other fasteners S. For example, the plate or other member P can include one or more holes or other openings that are sized, shaped, oriented and/or otherwise configured to secure a screw or other fastener therethrough, as desired or required. In some embodiments, the plate P is sized, shaped and configured to be flush or substantially flush with adjacent surfaces of the upper and lower vertebrae.

[0077] To assist in the description of the disclosed embodiments, words such as upward, upper, bottom, downward, lower, rear, front, vertical, horizontal, upstream,

downstream have been used above to describe different embodiments and/or the accompanying figures. It will be appreciated, however, that the different embodiments, whether illustrated or not, can be located and oriented in a variety of desired positions.

[0078] Although several embodiments and examples are disclosed herein, the present application extends beyond the specifically disclosed embodiments to other alternative embodiments and/or uses of the inventions and modifications and equivalents thereof. It is also contemplated that various combinations or subcombinations of the specific features and aspects of the embodiments may be made and still fall within the scope of the inventions. Accordingly, it should be understood that various features and aspects of the disclosed embodiments can be combine with or substituted for one another in order to form varying modes of the disclosed inventions. Thus, it is intended that the scope of the present inventions herein disclosed should not be limited by the particular disclosed embodiments described above, but should be determined only by a fair reading of the claims that follow.

[0079] While the inventions are susceptible to various modifications, and alternative forms, specific examples thereof have been shown in the drawings and are herein described in detail. It should be understood, however, that the inventions are not to be limited to the particular forms or methods disclosed, but, to the contrary, the inventions are to cover all modifications, equivalents, and alternatives falling within the spirit and scope of the various embodiments described and the appended claims. Any methods disclosed herein need not be performed in the order recited. The methods summarized above and set forth in further detail below describe certain actions taken by a practitioner; however, it should be understood that they can also include the instruction of those actions by another party. Thus, actions such as “advancing an implant” include “instructing advancing an implant.” The ranges disclosed herein also encompass any and all overlap, sub-ranges, and combinations thereof. Language such as “up to,” “at least,” “greater than,” “less than,” “between,” and the like includes the number recited. Numbers preceded by a term such as “about” or “approximately” include the recited numbers. For example, “about 10 mm” includes “10 mm.” Terms or phrases preceded by a term such as “substantially” include the recited term or phrase. For example, “substantially parallel” includes “parallel.”

WHAT IS CLAIMED IS:

1. A method of inserting an implant within an intervertebral space defined between an upper vertebral member and a lower vertebral member, the method comprising:
  - positioning a plate system within the intervertebral space, wherein the plate system comprises an upper plate and a lower plate; and
  - advancing an implant between the upper plate and the lower plate so that the implant is urged into the intervertebral space, the upper plate engages the upper vertebral member, and the lower plate engages the lower vertebral member;
  - wherein, upon advancement of the implant between the upper and lower plates, the upper vertebral member is distracted relative to the lower vertebral member.
2. The method of Claim 1, wherein advancing an implant between the upper and lower base plates comprises using a device.
3. The method of Claim 2, wherein the device comprises a mechanical device or a pneumatic device.
4. The method of Claim 1, wherein advancing the implant between the upper plate and the lower plate comprises advancing the implant at least partially through a guiding assembly.
5. The method of Claim 4, where the guiding assembly comprises upper and lower guiding members or plates, wherein the upper and lower guiding members or plates are configured to removably engage corresponding portions of the upper and lower plates when the implant is advanced into the intervertebral space.
6. The method of Claim 1, wherein advancing the implant between the upper and lower plates deploys at least one engagement member or feature of at least one of the upper plate or the lower plate, wherein the at least one engagement member or feature is configured to engage at least a portion of the an adjacent vertebral member.
7. The method of Claim 6, wherein the at least one engagement member or feature comprises a tooth or spike.
8. The method of Claim 1, wherein the implant is configured to be advanced between the upper and lower plates using a rail system.

9. The method of Claim 8, wherein the rail system comprises at least one protruding member or feature on the implant and at least one corresponding groove or recess on the upper plate or lower plate, wherein the at least one protruding member or feature is configured to slidably move within the at least one corresponding groove or recess on the upper plate or lower plate.

10. The method of Claim 8, wherein the rail system comprises at least one groove or recess on the implant and at least one corresponding protruding member or feature on the upper plate or lower plate, wherein the at least one protruding member or feature is configured to slidably move within the at least one corresponding groove or recess.

11. The method of Claim 1, wherein the implant comprises a generally smooth outer surface.

12. The method of Claim 1, wherein the implant does not comprise any teeth or other engagement features.

13. The method of Claim 1, wherein the implant comprises PEEK or titanium.

14. The method of Claim 1, wherein the upper and lower plates comprise at least one metal or alloy.

15. The method of Claim 14, wherein the at least one metal or alloy comprises at least one of titanium and stainless steel.

16. The method of Claim 1, further comprising securing at least one screw through an opening of the implant after the implant has been properly secured within the intervertebral space.

17. The method of Claim 16, wherein the at least one screw passes through at least a portion of the upper or lower plate.

18. The method of Claim 16, wherein the at least one screw passes through at least a portion of the upper or lower vertebral member.

19. The method of Claim 1, further comprising creating a lateral passage through a subject in order to provide minimally invasive access to the intervertebral space.

20. The method of Claim 1, further comprising clearing out native tissue of the subject within and/or near the intervertebral space.

21. A spinal fusion system comprising:  
a plate system configured for placement within an intervertebral space of a subject, wherein the plate system comprises an upper plate and a lower plate;  
an implant configured to be advanced and positioned between the upper plate and the lower plate to secure the implant within the intervertebral space;  
wherein, when the implant is advanced between the upper plate and the lower plate, the upper plates engages the upper vertebral member, and the lower plate engages the lower vertebral member;  
wherein, upon advancement of the implant between the upper and lower plates, the upper vertebral member is distracted relative to the lower vertebral member.
22. The system of Claim 21, further comprising a guiding assembly comprising upper and lower slides, wherein the upper slide is configured to removably couple to the upper plate, and wherein the lower slide is configured to removably couple to the lower plate.
23. The system of Claim 22, wherein at least one of the upper plate and the lower plate comprises at least one engagement member configured to engage a portion of the adjacent vertebral member when the implant has been advanced between the upper and lower plates.
24. The system of Claim 23, wherein the at least one engagement member comprises a tooth, spike or barb.
25. The system of Claim 21, wherein the implant is configured to be advanced between the upper and lower plates using a rail system.
26. The system of 25, wherein the rail system comprises at least one protruding member or feature on the implant and at least one corresponding groove or recess on the upper plate or lower plate, wherein the at least one protruding member or feature is configured to slidably move within the at least one corresponding groove or recess on the upper plate or lower plate.

27. The system of 25, wherein the rail system comprises at least one groove or recess on the implant and at least one corresponding protruding member or feature on the upper plate or lower plate, wherein the at least one protruding member or feature is configured to slidably move within the at least one corresponding groove or recess.

28. The system of Claim 21, wherein the implant comprises a generally smooth outer surface.

29. The system of Claim 21, wherein the implant does not comprise any teeth or other engagement features.

30. The system of Claim 21, wherein the implant comprises PEEK or titanium.

31. The system of Claim 21, wherein the upper and lower plates comprise at least one metal or alloy.

32. The system of Claim 31, wherein the at least one metal or alloy comprises at least one of titanium and stainless steel.

33. The system of Claim 21, wherein at least one of the upper and lower plates comprises PEEK or another polymeric material.

34. The system of Claim 21, further comprising at least one screw, the at least one screw being configured to be secured through an opening of the implant after the implant has been properly secured within the intervertebral space.

35. The system of Claim 34, wherein the at least one screw passes through at least a portion of the upper or lower plate.

36. The system of Claim 34, wherein the at least one screw passes through at least a portion of the upper or lower vertebral member.

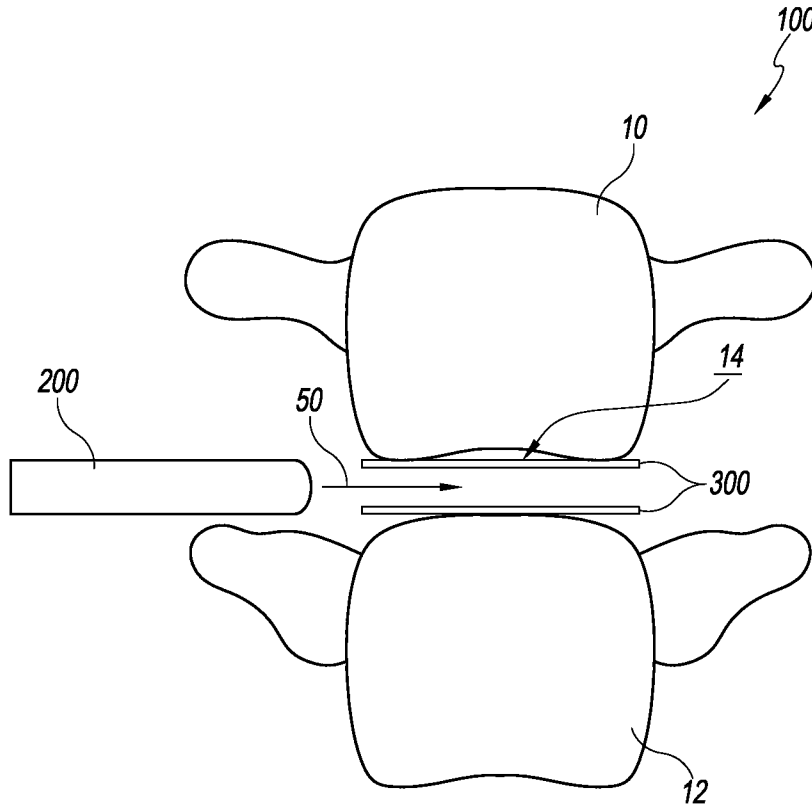

FIG. 1

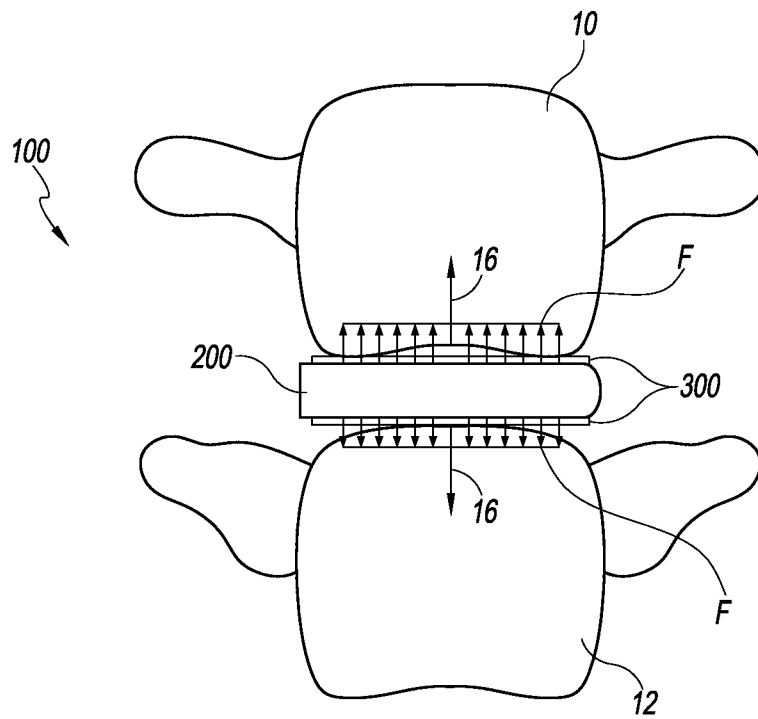

FIG. 2

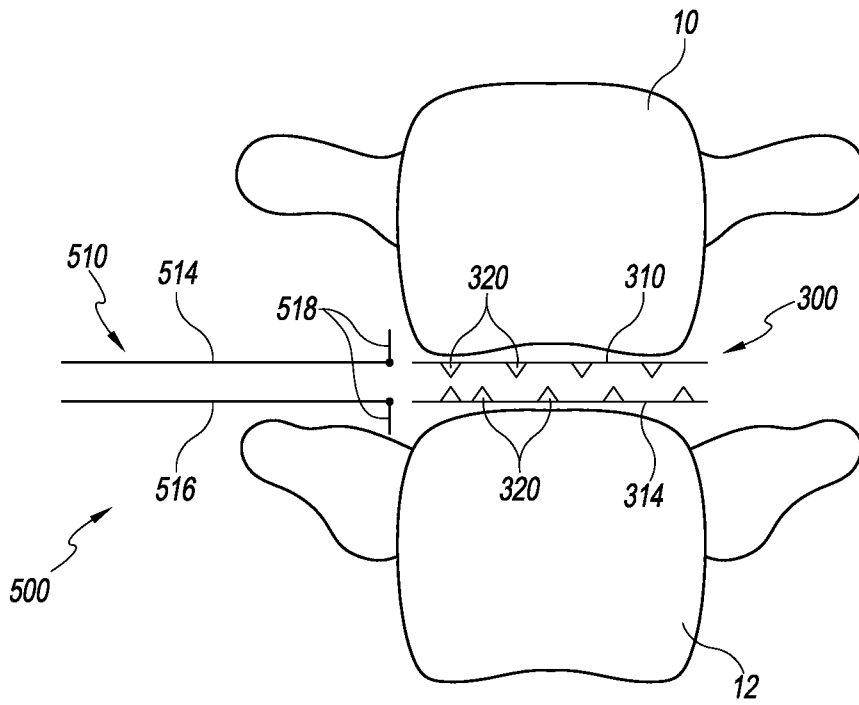

FIG. 3A

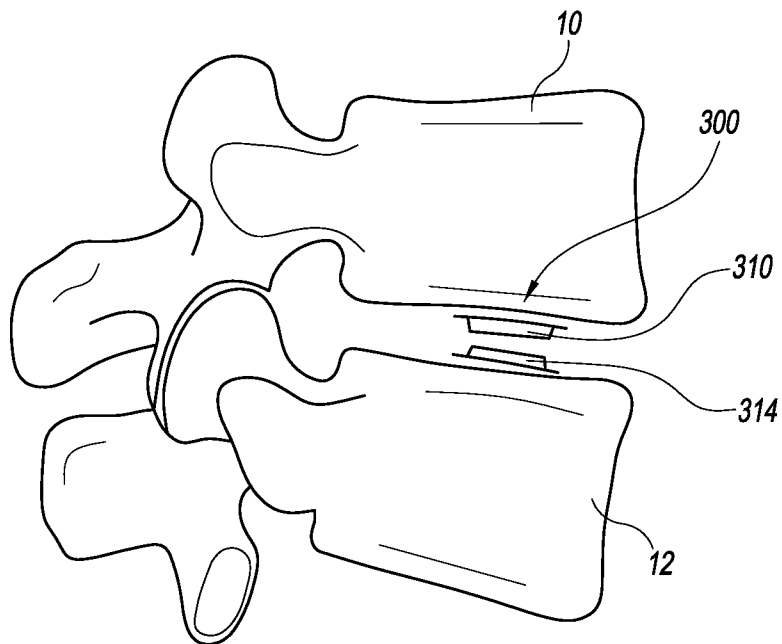

FIG. 3B

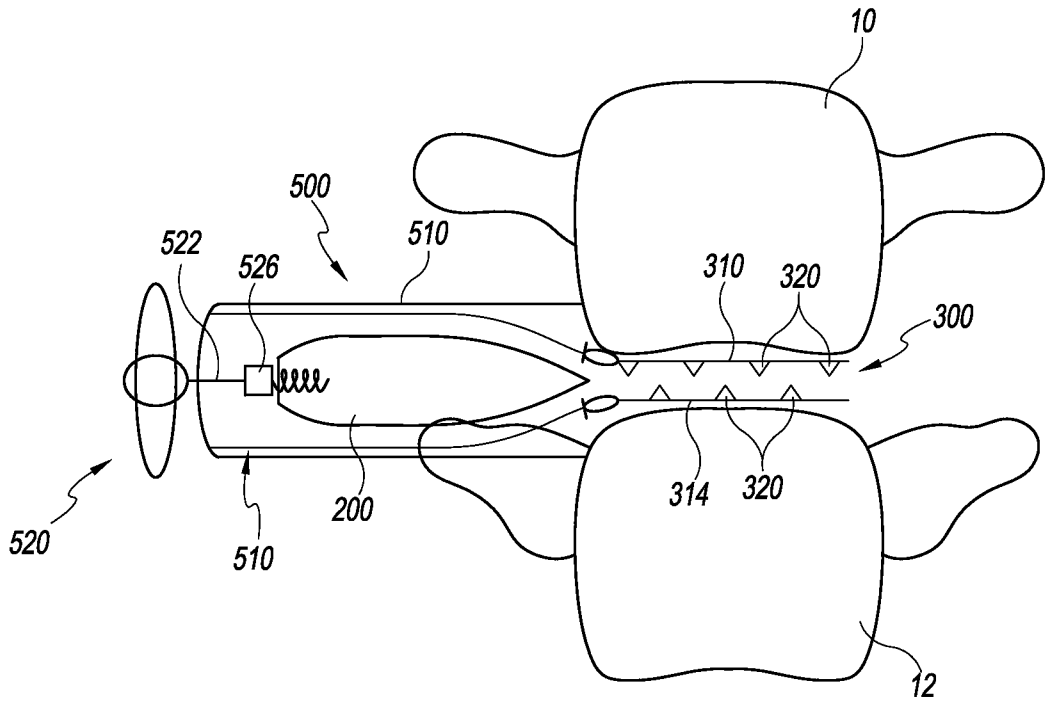

FIG. 4

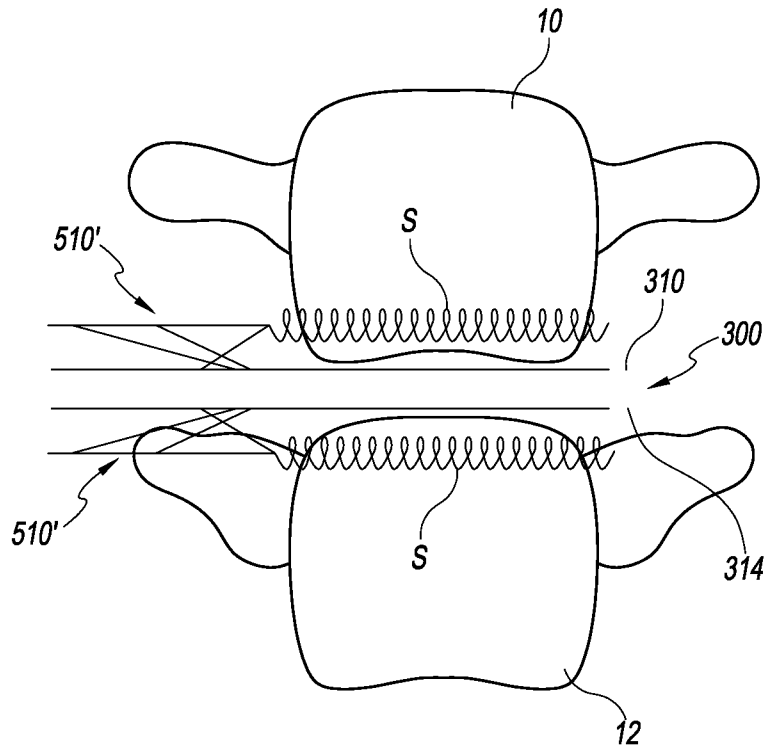

FIG. 5A

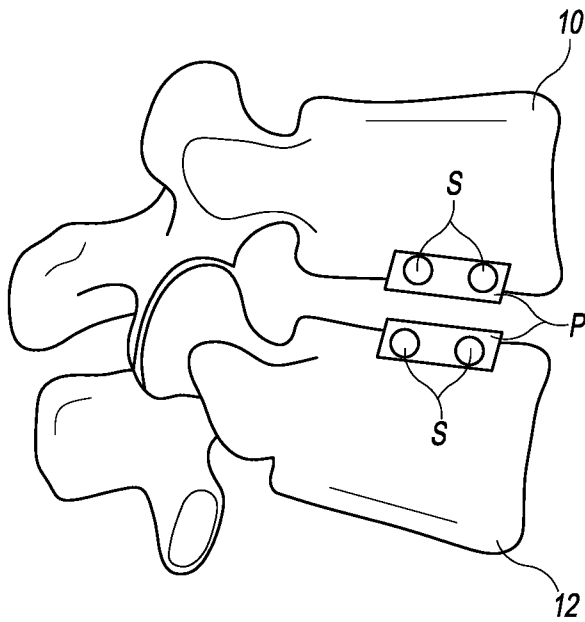

FIG. 5B

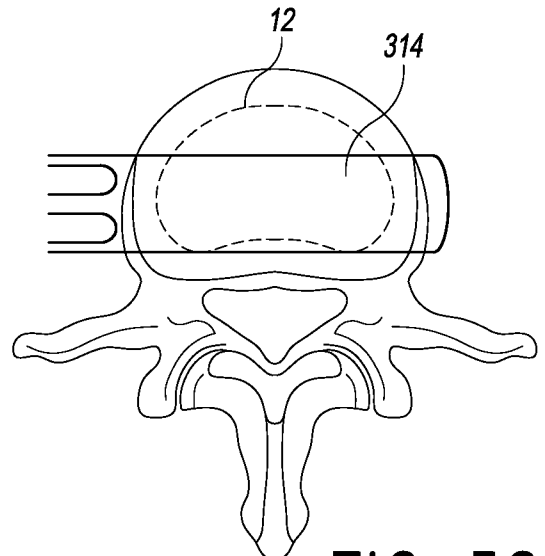

FIG. 5C

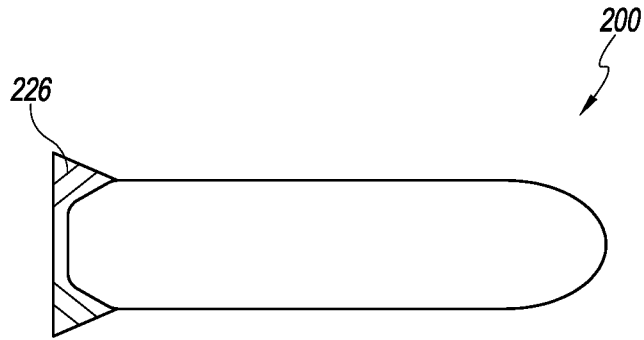

FIG. 6A

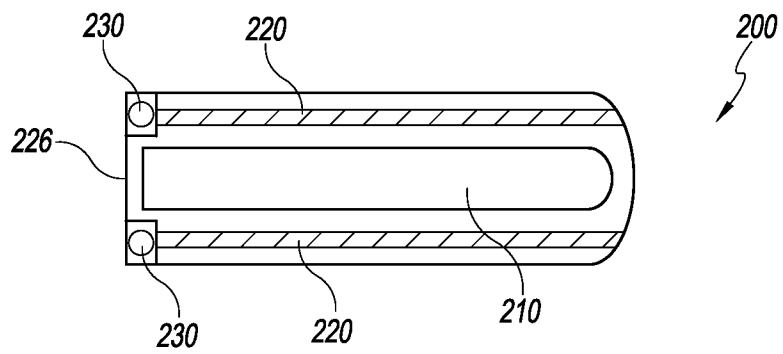

FIG. 6B

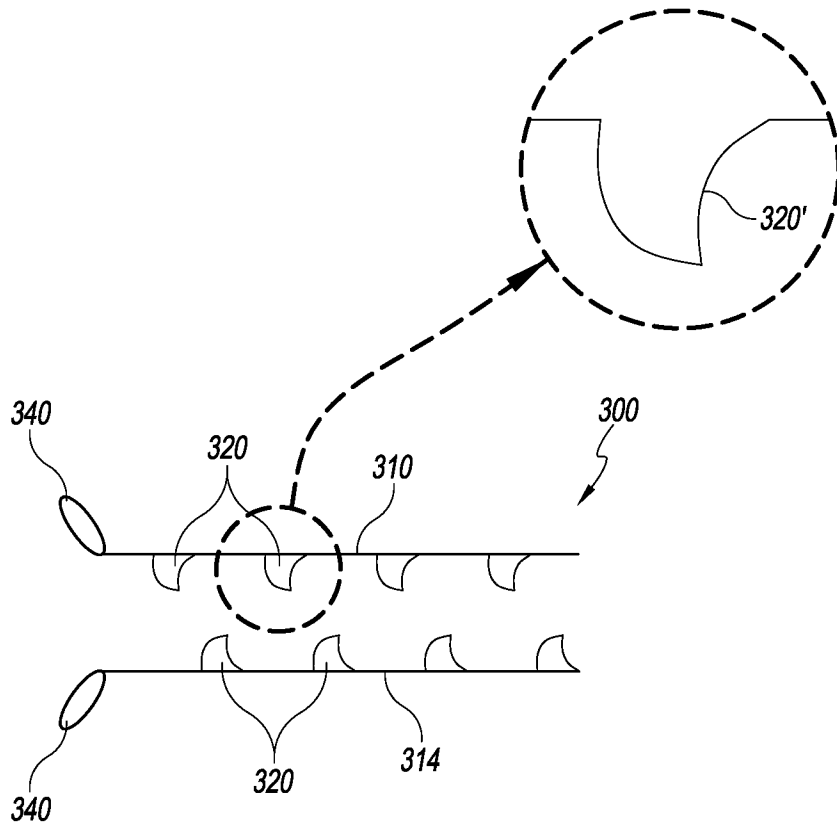

FIG. 7A

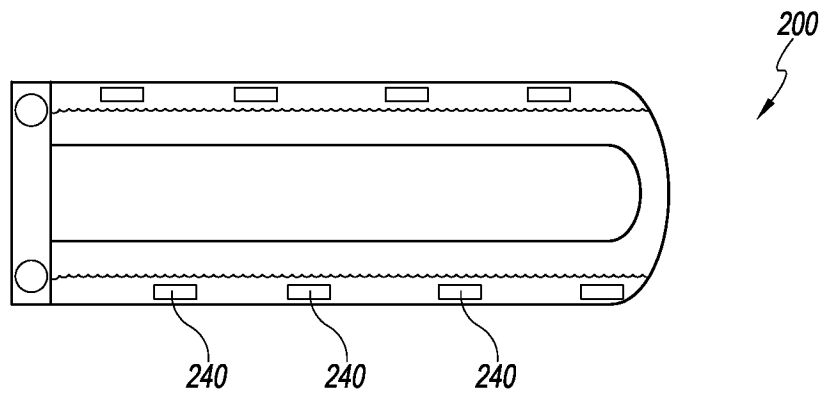
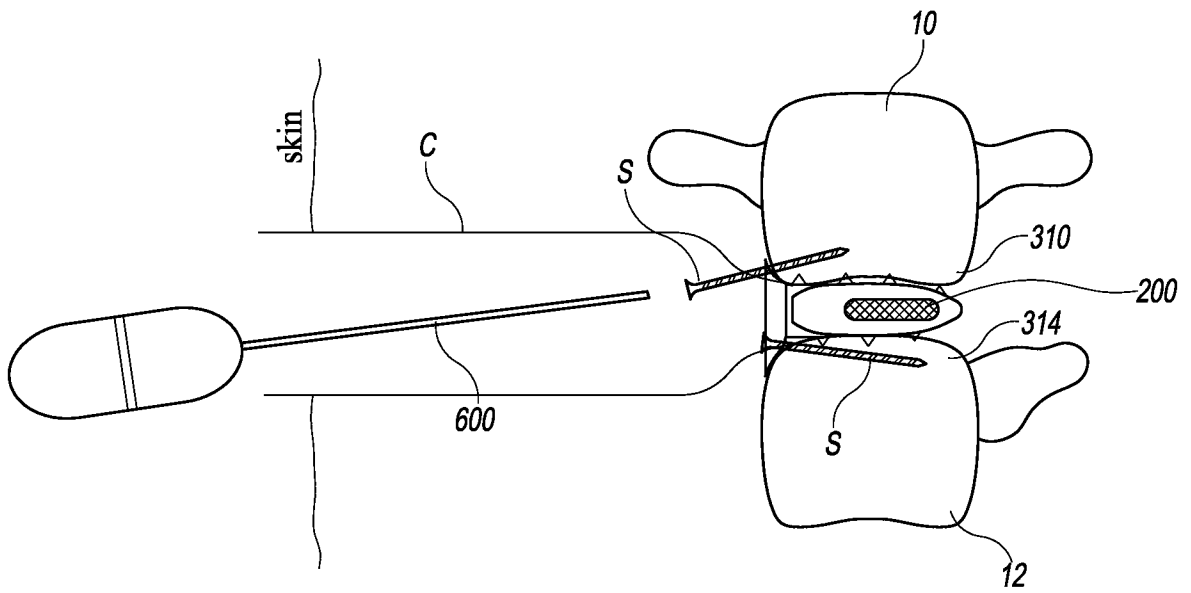
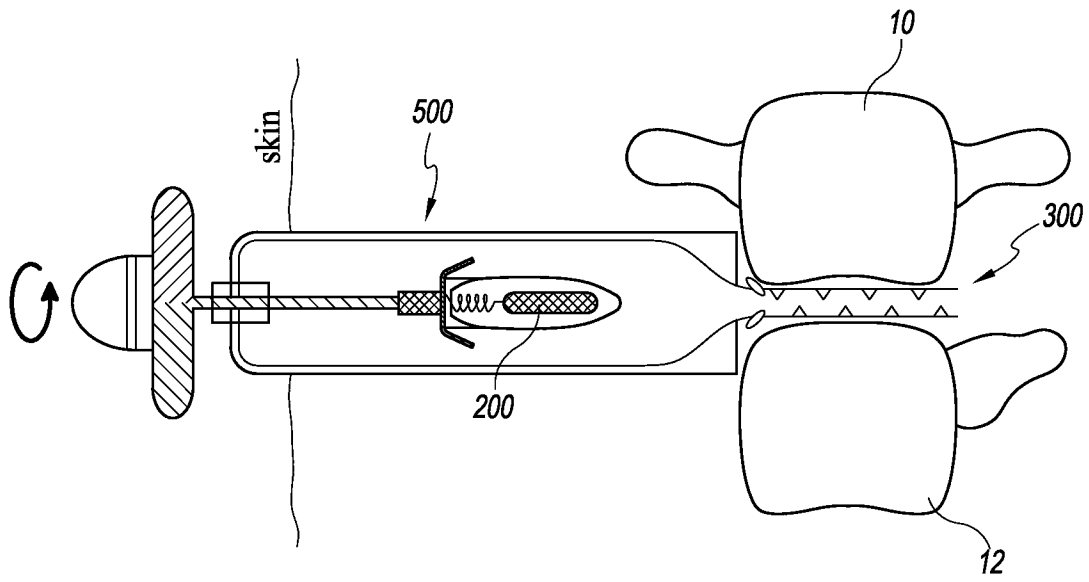

FIG. 7B



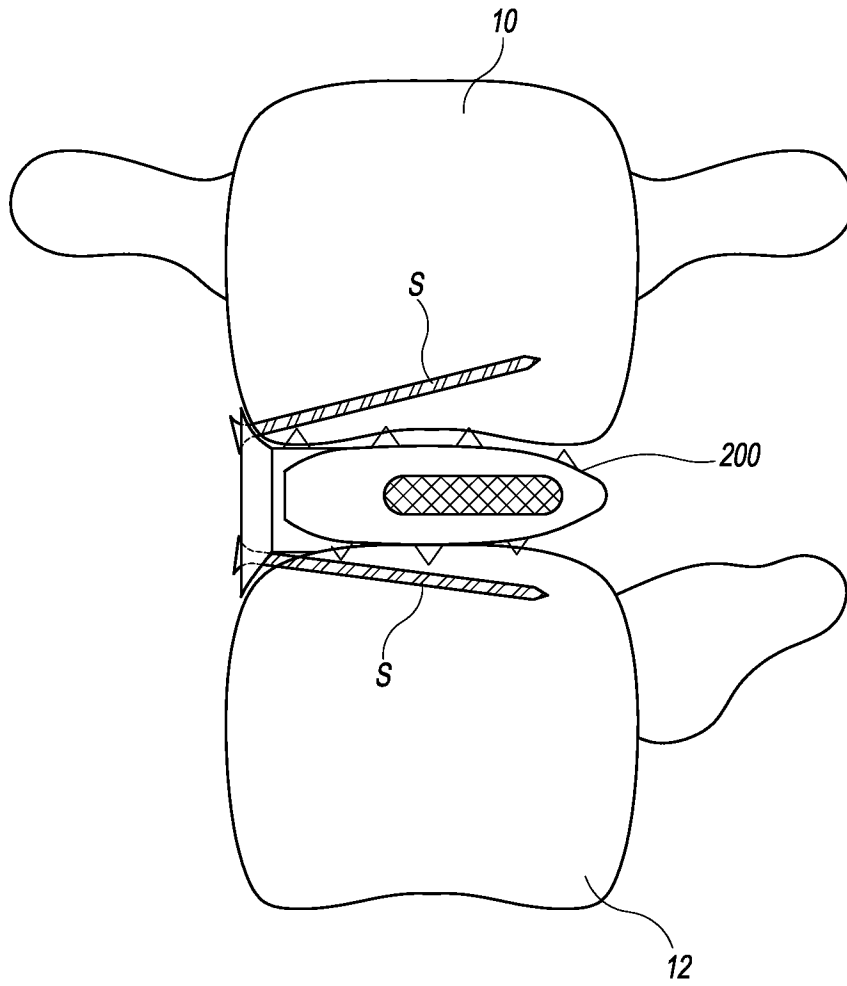

FIG. 8C

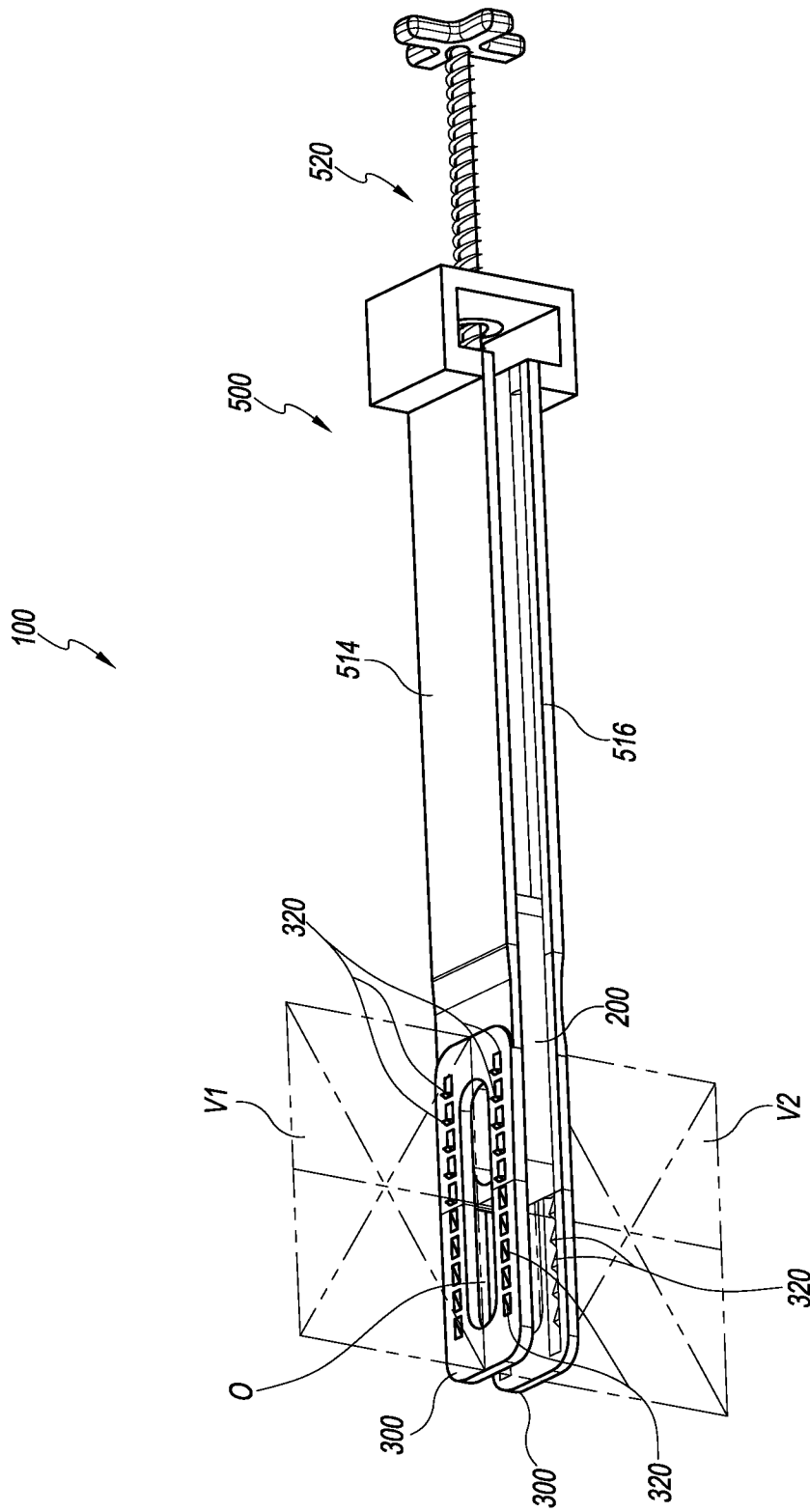

FIG. 9A

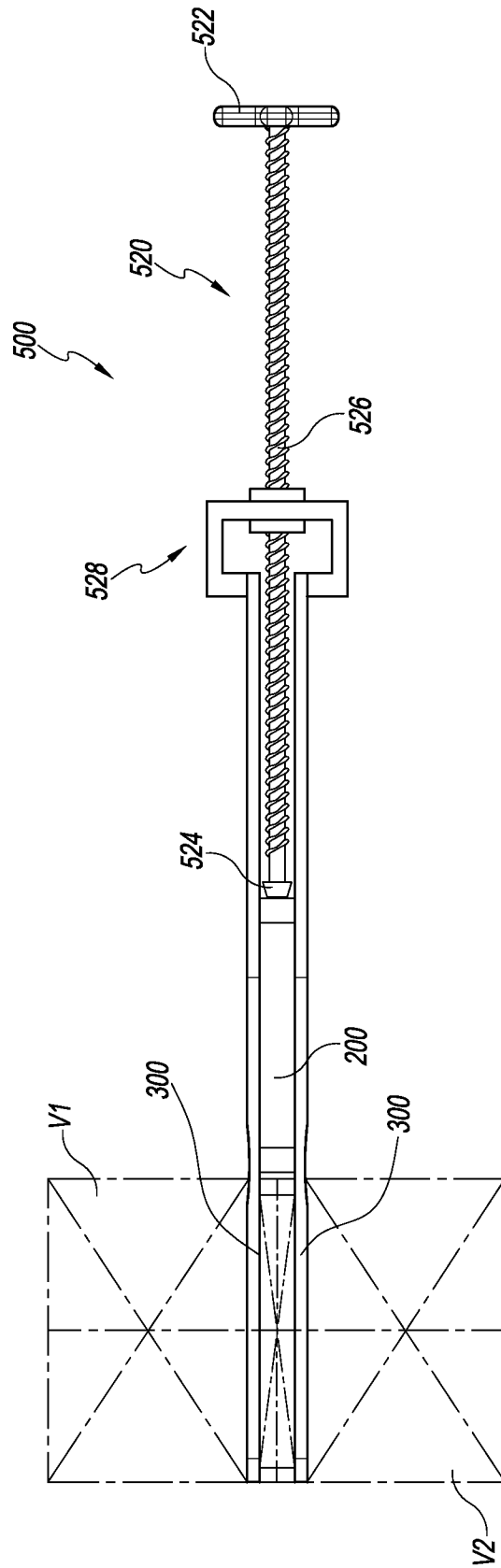

FIG. 9B

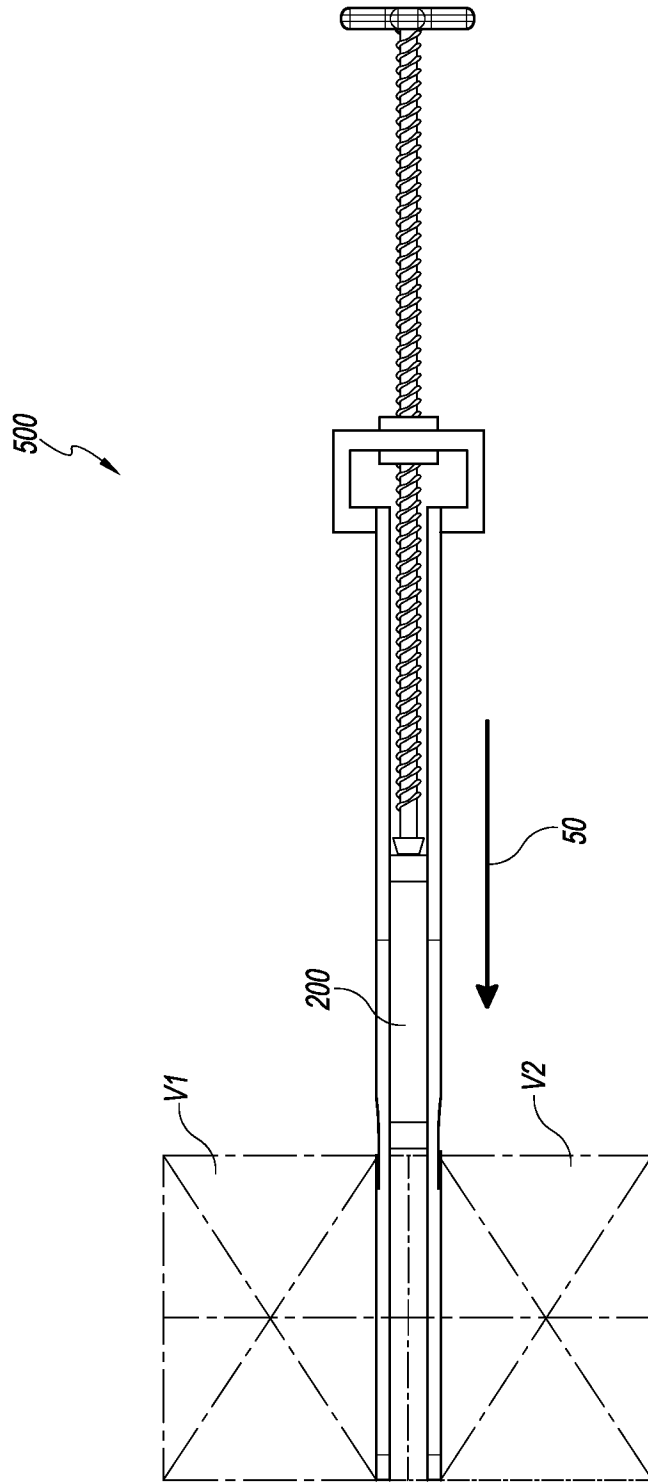

FIG. 9C

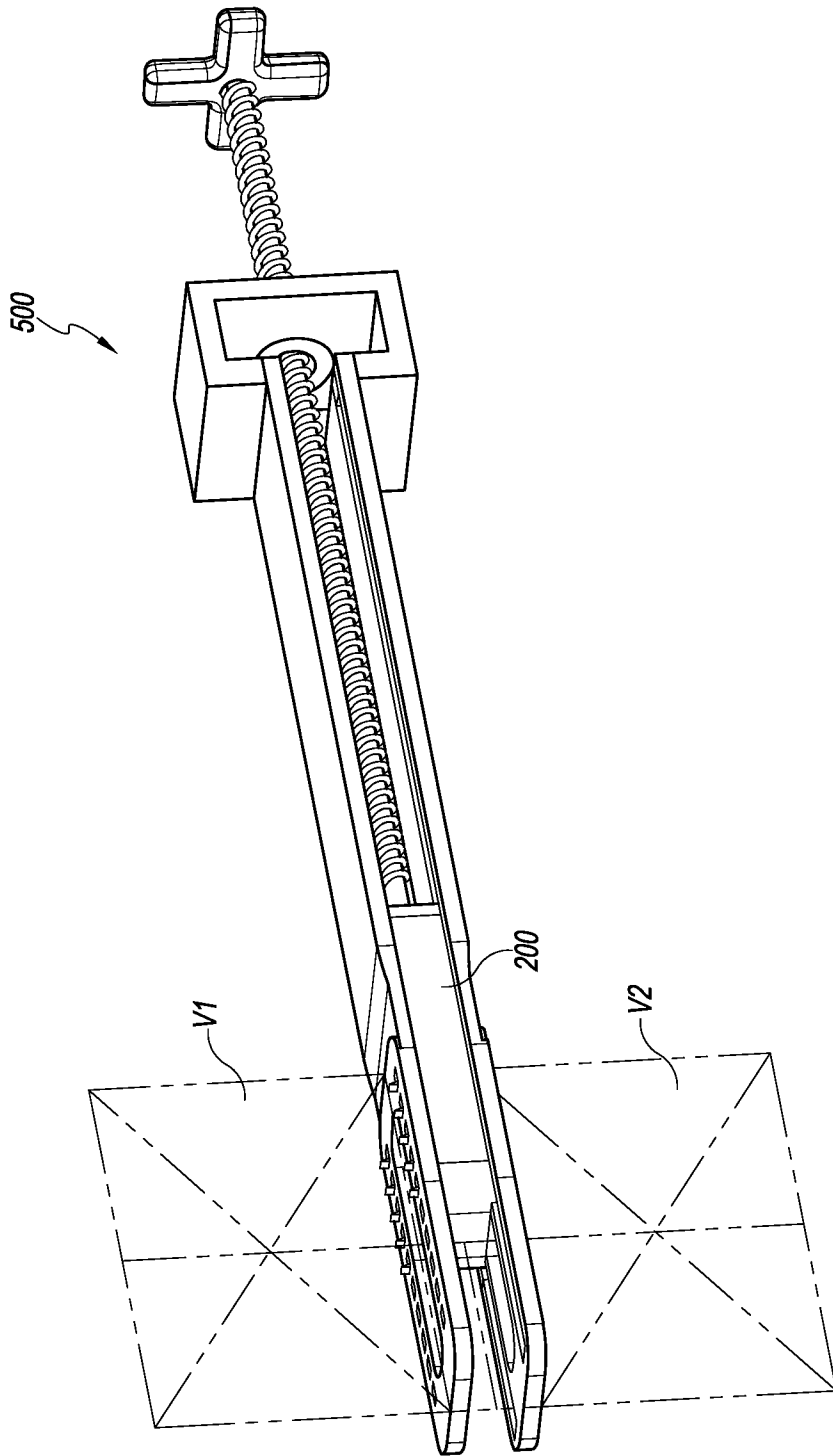

FIG. 9D

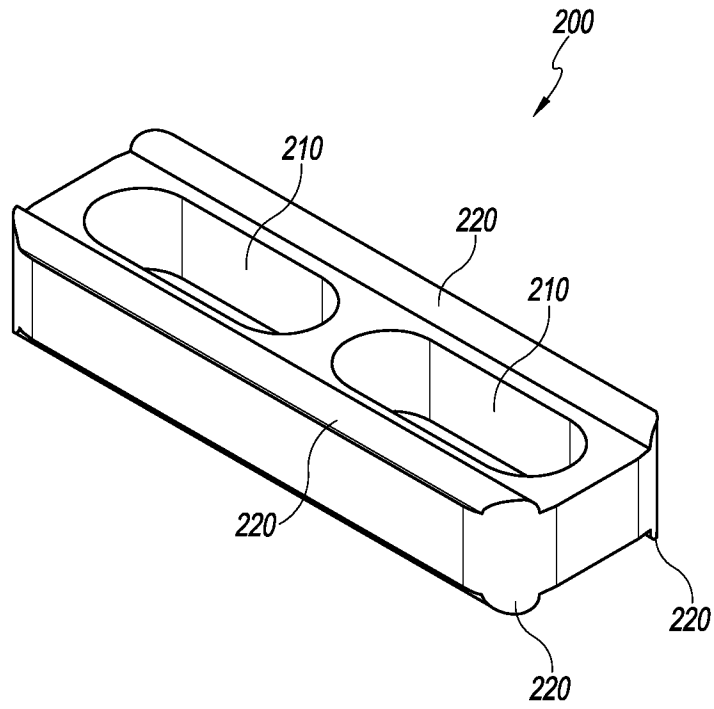

FIG. 10A

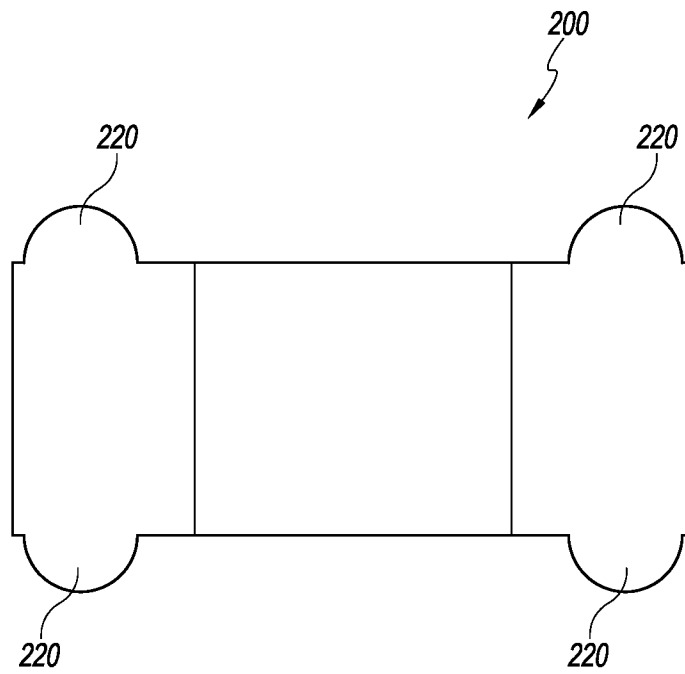

FIG. 10B

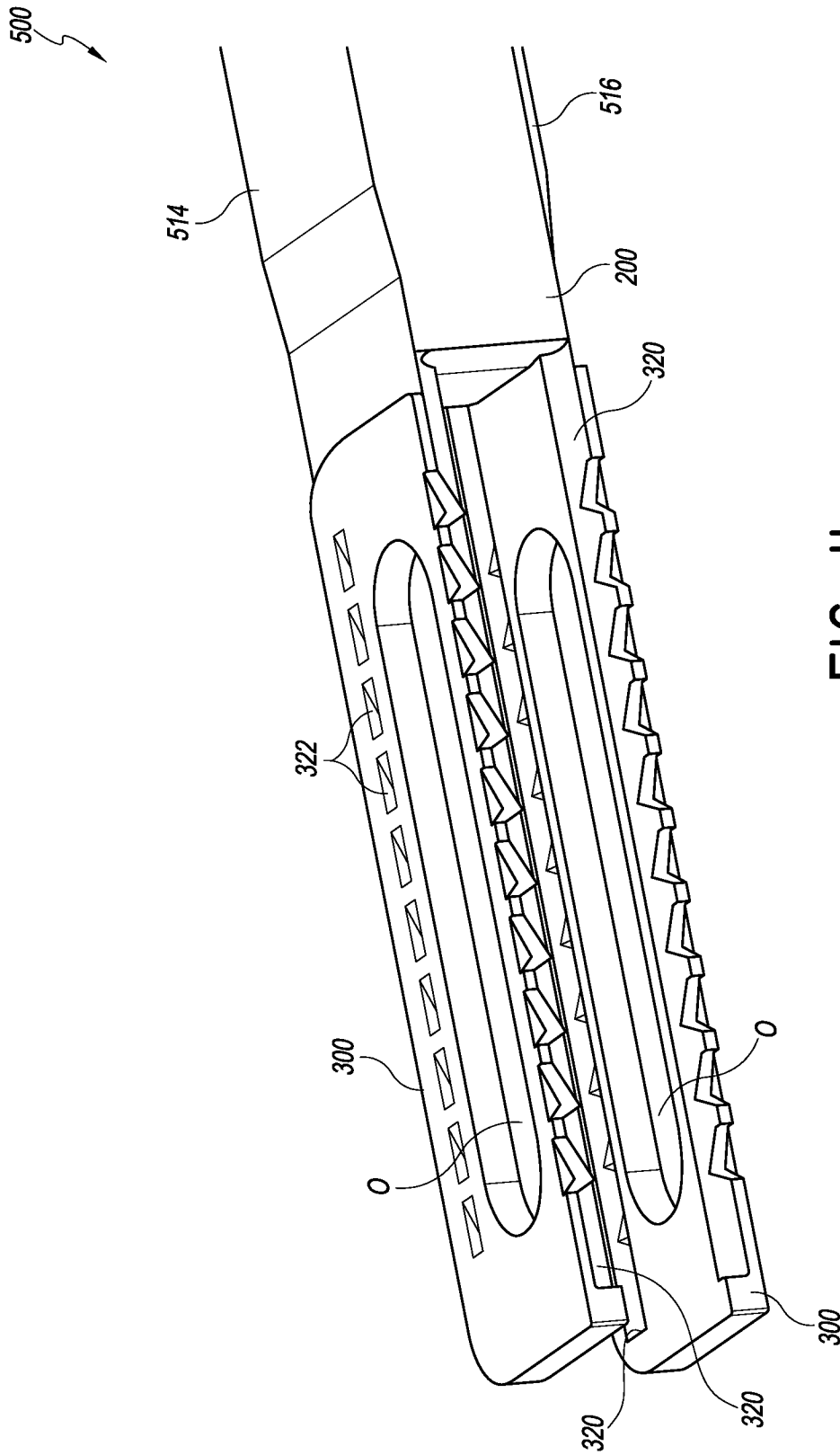

FIG. II

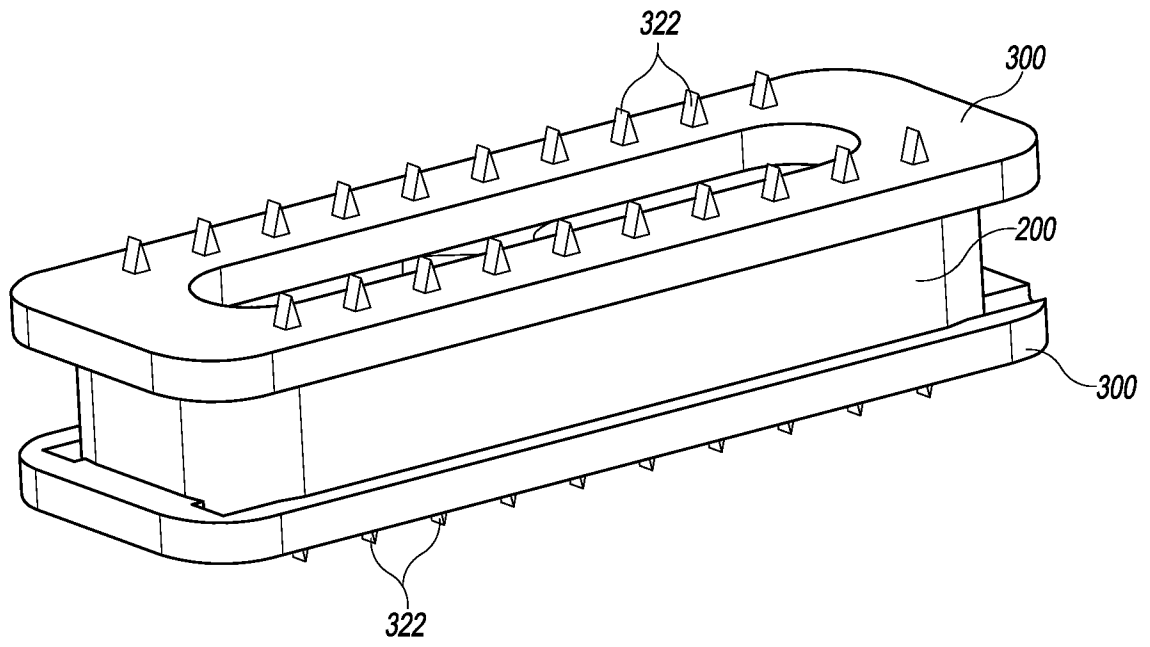

FIG. 12

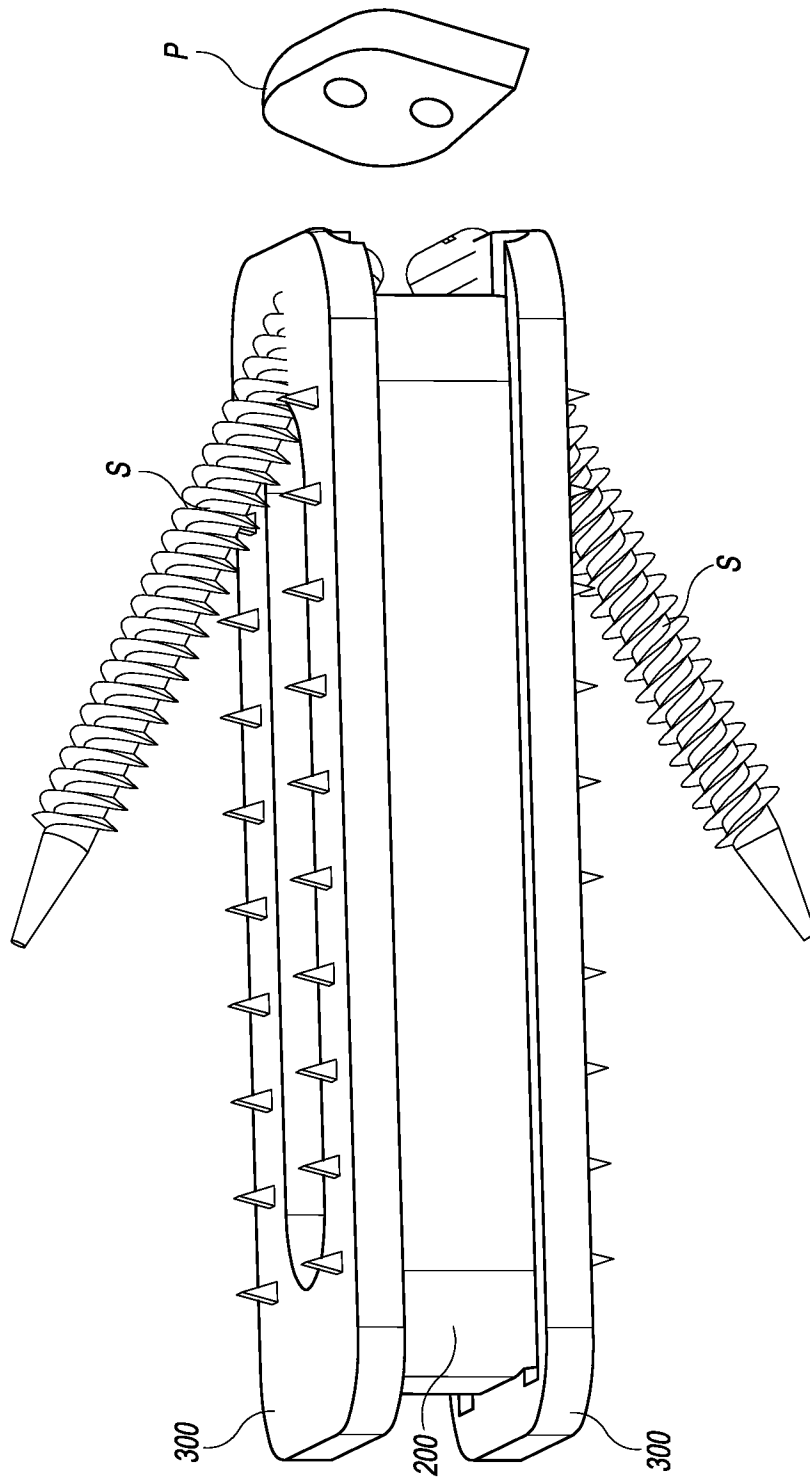

FIG. 13

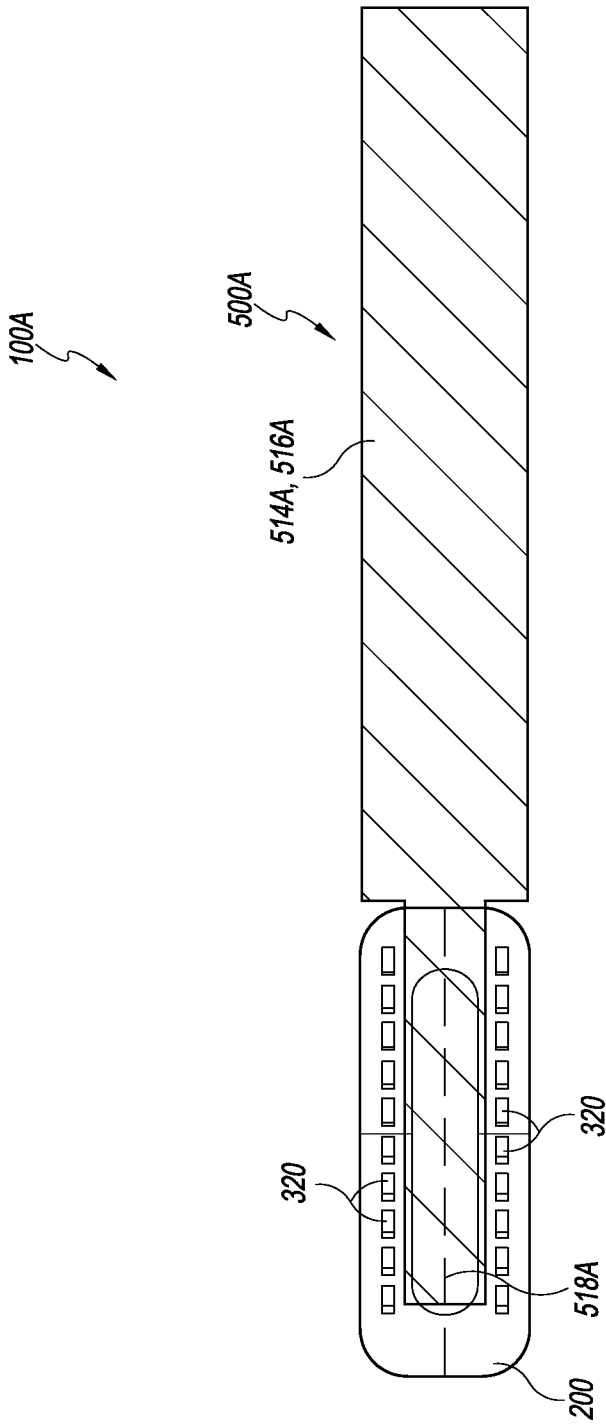

FIG. 14

**INTERNATIONAL SEARCH REPORT**

International application No.

PCT/US2014/025035

**A. CLASSIFICATION OF SUBJECT MATTER**

IPC(8) - A61F 2/44 (2014.01)  
USPC - 623/17.11

According to International Patent Classification (IPC) or to both national classification and IPC

**B. FIELDS SEARCHED**

Minimum documentation searched (classification system followed by classification symbols)  
IPC(8) - A61B 17/70, 17/88; A61F 2/44, 2/46 (2014.01)  
USPC - 606/86A, 279; 623/17.11, 17.15, 17.16

Documentation searched other than minimum documentation to the extent that such documents are included in the fields searched  
CPC - A61F 2/442, 2/4611, 2310/00023 (2014.06)

Electronic data base consulted during the international search (name of data base and, where practicable, search terms used)  
PatBase, Google Patents, Google

**C. DOCUMENTS CONSIDERED TO BE RELEVANT**

Category*	Citation of document, with indication, where appropriate, of the relevant passages	Relevant to claim No.
X	US 2007/0032871 A1 (MICHELSON) 08 February 2007 (08.02.2007) entire document	1-6, 8, 9, 11-15, 21-23, 25, 26, 28-32
-		
Y		7, 10, 16-20, 24, 27, 33-36
Y	US 2012/0265250 A1 (ALI) 18 October 2012 (18.10.2012) entire document	7, 16-20, 24, 34-36
Y	US 2009/0112320 A1 (KRAUS) 30 April 2009 (30.04.2009) entire document	10, 27
Y	US 2008/0039947 A1 (ZUCHERMAN et al) 14 February 2008 (14.02.2008) entire document	33

Further documents are listed in the continuation of Box C.

* Special categories of cited documents:	"T" later document published after the international filing date or priority date and not in conflict with the application but cited to understand the principle or theory underlying the invention
"A" document defining the general state of the art which is not considered to be of particular relevance	"X" document of particular relevance; the claimed invention cannot be considered novel or cannot be considered to involve an inventive step when the document is taken alone
"E" earlier application or patent but published on or after the international filing date	"Y" document of particular relevance; the claimed invention cannot be considered to involve an inventive step when the document is combined with one or more other such documents, such combination being obvious to a person skilled in the art
"L" document which may throw doubts on priority claim(s) or which is cited to establish the publication date of another citation or other special reason (as specified)	"&" document member of the same patent family
"O" document referring to an oral disclosure, use, exhibition or other means	
"P" document published prior to the international filing date but later than the priority date claimed	

Date of the actual completion of the international search  
01 July 2014

Date of mailing of the international search report

**18 JUL 2014**

Name and mailing address of the ISA/US  
Mail Stop PCT, Attn: ISA/US, Commissioner for Patents  
P.O. Box 1450, Alexandria, Virginia 22313-1450  
Facsimile No. 571-273-3201

Authorized officer:  
Blaine R. Copenheaver

PCT Helpdesk: 571-272-4300  
PCT OSP: 571-272-7774