

(19) **DANMARK**

(10) **DK/EP 3615791 T3**



Patent- og  
Varemærkestyrelsen

(12) **Oversættelse af  
europæisk patentskrift**

- 
- (51) Int.Cl.: **F 03 D 80/30 (2016.01)** **F 03 D 1/06 (2006.01)**
- (45) Oversættelsen bekendtgjort den: **2022-06-27**
- (80) Dato for Den Europæiske Patentmyndigheds bekendtgørelse om meddelelse af patentet: **2022-05-25**
- (86) Europæisk ansøgning nr.: **17720761.0**
- (86) Europæisk indleveringsdag: **2017-04-26**
- (87) Den europæiske ansøgnings publiceringsdag: **2020-03-04**
- (86) International ansøgning nr.: **EP2017059942**
- (87) Internationalt publikationsnr.: **WO2018196967**
- (84) Designerede stater: **AL AT BE BG CH CY CZ DE DK EE ES FI FR GB GR HR HU IE IS IT LI LT LU LV MC MK MT NL NO PL PT RO RS SE SI SK SM TR**
- (73) Patenthaver: **VESTAS WIND SYSTEMS A/S, Hedeager 42, 8200 Århus N, Danmark**
- (72) Opfinder: **Sato, Kenji, c/o MHI Vestas Offshore Wind A/S, Dusager 4, 8200 Århus N, Danmark**  
**HIRAISHI, Masayuki, c/o MHI Vestas Offshore Wind A/S, Dusager 4, 8200 Århus N, Danmark**
- (74) Fuldmægtig i Danmark: **Plougmann Vingtoft A/S, Strandvejen 70, 2900 Hellerup, Danmark**
- (54) Benævnelse: **VINDMØLLEVINGE OG VINDMØLLESTRØMGENERERINGSAPPARAT**
- (56) Fremdragne publikationer:  
**EP-A2- 2 267 280**  
**WO-A1-2011/080177**  
**DE-A1-102015 200 370**  
**GB-A- 2 527 035**  
**JP-B2- 5 730 408**  
**US-A1- 2014 186 175**



# DESCRIPTION

## TECHNICAL FIELD

[0001] The present invention relates to a wind turbine blade and a wind turbine power generating apparatus.

## BACKGROUND ART

[0002] Typically, a wind turbine blade is provided with a lightning protection facility for reducing damage to a blade body from lightning strikes. For instance, EP 2 226 497 A discloses a wind turbine blade including a metal receptor (lightning receiving portion) on a blade tip.

[0003] GB 2527035 A discloses a wind turbine blade which has a blade body portion that comprises a first blade portion which is a blade tip which is constructed of metal or has a metallic outer surface, wherein the first blade portion is connected to a second blade portion extending towards a root so as to define a junction between them that extends transversely around the blade surface of the blade. The wind turbine blade has a protective cowl structure which is fixed to the wind turbine blade and is arranged to cover at least a portion of the junction. The cowl structure protects the junction between the blade portions from environmental damage, especially lightning. The cowl may be formed of a polymeric material, such as polyurethane with a dielectric outer surface.

[0004] JP 5730408 B2 discloses a wind turbine blade with a blade body portion extending from a blade root portion toward a blade tip portion in a blade spanwise direction and having a metal receptor including a blade tip of the wind turbine blade. The blade body portion is connected to the metal receptor so as to be positioned on a blade-root side of the metal receptor, and the blade body portion having a hollow structure and forming an airfoil shape in a blade tip region of the wind turbine blade with the metal receptor in a joint region to the metal receptor. A joint line between the metal receptor and the blade body portion extends in the chordwise direction of the blade.

## SUMMARY

### Problems to be Solved

[0005] A wind turbine blade gets hit by foreign substances in the air (e.g. raindrops, dusts) when a rotor rotates, and the collision results in occurrence of erosion on a leading-edge side

of the wind turbine blade. In particular, if a foreign substance hits a joint portion between a blade body portion and a receptor, cracks may develop on the blade body portion starting from the leading-edge side of the joint portion.

**[0006]** An object of the present invention is to suppress erosion damage to a wind turbine blade.

### **Solution to the Problems**

**[0007]** (1) A wind turbine blade according to the present invention comprises the features of claim 1 including inter alia: a metal receptor forming a blade tip of the wind turbine blade; and a blade body portion connected to the metal receptor so as to be positioned on a blade-root side of the metal receptor, the blade body portion having a hollow structure and forming an airfoil shape in a blade tip region of the wind turbine blade with the metal receptor in a joint region to the metal receptor. As seen in a blade-thickness direction of the wind turbine blade, a tangent to a joint line between the metal receptor and the blade body portion at an intersection between the joint line and a leading edge of the wind turbine blade is inclined from a chordwise direction of the wind turbine blade.

**[0008]** With the above configuration (1), the joint surface between the metal receptor and the blade body portion having a hollow structure is inclined from the chordwise direction, and thereby the collision angle formed by a foreign substance (e.g. raindrops, dusts) with the leading edge of the wind turbine blade is not the same as the tangent direction of the joint surface. Accordingly, it is possible to mitigate concentration of shock on the joint portion when a foreign substance hits the wind turbine blade, and thereby to suppress erosion on the joint surface and erosion damage to the wind turbine blade.

**[0009]** It is especially effective to suppress erosion on the joint surface between the metal receptor and the blade body portion in a case where the blade body portion has a "hollow structure". That is, in a case where the blade body portion has a hollow structure, development of erosion on the joint surface between the metal receptor and the blade body portion may bring about formation of a communication path that connects inside and outside of the wind turbine blade, which may let through foreign substances into the inside (hollow section) of the blade body portion. In this context, it is technically beneficial to be able to suppress erosion on the joint surface as described above.

**[0010]** In the present specification, "blade-thickness direction" refers to a direction perpendicular to both of the blade spanwise direction and the chordwise direction of the wind turbine blade.

**[0011]** (2) Preferably, as seen in the blade-thickness direction of the wind turbine blade, the joint line may be curved or bended so that an intersection between the joint line and a trailing edge of the wind turbine blade is positioned closer to the blade tip than an intersection

between the tangent and the trailing edge of the wind turbine blade.

**[0012]** With the above configuration (2), the joint line between the metal receptor and the blade body portion having a hollow structure may have a non-linear shape from the leading edge to the trailing edge in a range where the intersection between the joint line and the trailing edge of the wind turbine blade is closer to the blade tip than the intersection between the tangent and the trailing edge of the wind turbine blade. Accordingly, it is possible to improve the design flexibility of the shape of the joint portion between the metal receptor and the blade body portion, and thereby it is possible to select a shape for the metal receptor from among a variety of shapes to reduce erosion damage to the wind turbine blade more appropriately.

**[0013]** (3) In the invention, the tangent is inclined from the chordwise direction so as to get closer to the blade tip with distance from the leading edge toward the trailing edge of the wind turbine blade.

**[0014]** With this configuration (3), the metal receptor is disposed on the leading-edge side of the joint line, and thereby it is possible to protect the joint surface from collision with a foreign substance associated with rotation of the wind turbine blade, and to suppress erosion on the joint line effectively.

**[0015]** (4) Preferably, a length of the metal receptor along a blade spanwise direction may be at least 0.1% and not more than 0.9% of a blade length of the wind turbine blade, or at least 50mm and not more than 700mm.

**[0016]** With the above configuration (4), the length of the metal receptor is at least 0.1% of the blade length, or at least 50mm, and thus the metal receptor can exert a high lightning-protection performance. Furthermore, with the length of the metal receptor being at most 0.9% of the blade length, or at most 700mm, it is possible to suppress a weight increase of the wind turbine blade associated with a size increase of the metal receptor.

**[0017]** (5) Preferably, a width of the metal receptor along the chordwise direction may be at least 0.25% and not more than 0.9% of a blade length of the wind turbine blade, or at least 200mm and not more than 700mm.

**[0018]** With the above configuration (5), the width of the metal receptor is at least 0.25% of the blade length, or at least 200mm, and thus the metal receptor can exert a high lightning-protection performance. Furthermore, with the width of the metal receptor being at most 0.9% of the blade length, or at most 700mm, it is possible to suppress a weight increase of the wind turbine blade associated with a size increase of the metal receptor.

**[0019]** (6) Preferably, the joint line may have a curved shape with a curvature radius of not more than 0.009L, provided that L is a blade length of the wind turbine blade.

**[0020]** With the above configuration (6), the joint line has a curved shape, which makes it possible to ensure a sufficient inclination angle between the chordwise direction and the tangent to the joint line at the intersection between the leading edge and the joint line while suppressing concentration of the weight of the metal receptor toward the leading edge or toward the trailing edge, thus suppressing erosion at the joint line effectively.

**[0021]** (7) Preferably, the wind turbine blade may further comprise a first anti-erosion layer covering at least a part of an outer surface of the blade body portion.

**[0022]** With the above configuration (7), the first anti-erosion layer is provided to cover at least a part of the outer surface of the blade body portion, and thereby it is possible to suppress erosion damage to the wind turbine blade more effectively.

**[0023]** (8) Preferably, the wind turbine blade may further comprise a second anti-erosion layer covering at least a portion of the joint line between the metal receptor and the blade body portion, the portion being disposed on a side of the leading edge.

**[0024]** With the above configuration (8), the second anti-erosion layer is additionally provided, and thereby it is possible to cover the leading-edge side portion of the joint line between the metal receptor and the blade body portion. Accordingly, it is possible to suppress erosion on the joint surface even more effectively.

**[0025]** (9) Preferably, the wind turbine blade may further comprise a lightning-current transmission part including at least one of: a metal foil which is connected to the metal receptor and which extends from a connection section to the metal receptor toward a blade root of the wind turbine blade; or a down-conductor.

**[0026]** With the above configuration (9), the wind turbine blade further includes the lightning-current transmission part including at least one of the metal foil or the down-conductor, and thereby it is possible to exert the lightning-protection performance more reliably while achieving the effect to suppress erosion damage to the wind turbine blade described in the above (1).

**[0027]** (10) Preferably, the blade body portion may include an FRP shell which is connected to the metal receptor while overlapping the metal receptor.

**[0028]** With the above configuration (10), it is possible to achieve the effect to suppress erosion damage to the wind turbine blade described in the above (1), at the connection section between the metal receptor and the FRP shell having a hollow structure and being formed of FRP.

**[0029]** (11) Preferably, the metal receptor may have a cavity inside the metal receptor.

**[0030]** With the above configuration (11), the metal receptor has the cavity formed therein, and thereby it is possible to suppress a weight increase of the metal receptor while suppressing

erosion on the joint line.

**[0031]** (12) Preferably, the metal receptor may include a drain hole which is in communication with the cavity.

**[0032]** With this configuration (12), the metal receptor has the drain hole communicating with the cavity formed inside the metal receptor, and thereby it is possible to discharge foreign substances like raindrops that accumulate inside the cavity to outside through the drain hole, and to suppress erosion damage to the wind turbine blade.

**[0033]** (13) Preferably, the metal receptor may include: a first portion forming a pressure surface on a side of the blade tip of the wind turbine blade; and a second portion forming a suction surface on the side of the blade tip of the wind turbine blade, the second portion being fastened to the first portion.

**[0034]** With the above configuration (13), the metal receptor includes the first portion forming the pressure surface on the side of the blade tip and the second portion forming the suction surface on the side of the blade tip, and thereby it is possible to facilitate assembly and maintenance works of the blade body portion while achieving the effect to suppress erosion damage to the wind turbine blade described in the above (1).

**[0035]** (14) Preferably, the metal receptor may comprise copper or copper alloy.

**[0036]** With the above configuration (14), the metal receptor includes copper or copper alloy having a high conductivity, and thereby it is possible to exert the lightning-protection performance more reliably while achieving the effect to suppress erosion damage to the wind turbine blade described in the above (1).

**[0037]** (15) A wind turbine power generating apparatus according to the present invention has the features of claim 14 and comprises the wind turbine blade according to the invention.

**[0038]** With the above configuration (15), it is possible to provide a wind turbine power generating apparatus including a wind turbine blade whereby it is possible to suppress erosion at the joint surface effectively.

### **Advantageous Effects**

**[0039]** According to the present invention, it is possible to suppress erosion damage to a wind turbine blade.

### **BRIEF DESCRIPTION OF DRAWINGS**

**[0040]**

FIG. 1 is a diagram of a configuration example of a wind turbine power generating apparatus.

FIG. 2 is a perspective view of a wind turbine blade according to an embodiment.

FIGs. 3A and 3B are cross-sectional views taken along lines A-A and B-B in FIG. 2, respectively.

FIG. 4 is a planar view of a tip side of a wind turbine blade according to an embodiment.

FIG. 5 is a diagram of a blade tip portion of a wind turbine blade according to an example serving to explain aspects of the invention.

FIG. 6 is a diagram of a blade tip portion of a wind turbine blade according to another example serving to explain aspects of the invention.

FIG. 7 is a diagram of a blade tip portion of a wind turbine blade according to another example serving to explain aspects of the invention.

FIG. 8 is a diagram of a blade tip portion of a wind turbine blade according to another example serving to explain aspects of the invention.

FIG. 9 is a diagram of a blade tip portion of a wind turbine blade according to another embodiment.

FIG. 10 is a diagram of a blade tip portion of a wind turbine blade according to another embodiment.

FIG. 11 is a planar view of an anti-erosion layer in some embodiments.

FIG. 12 is a diagram of another configuration example of a wind turbine power generating apparatus.

FIG. 13 is a cross-sectional view of a tip side of a wind turbine blade according to an embodiment.

## **DETAILED DESCRIPTION**

**[0041]** Embodiments of the present invention will now be described in detail with reference to the accompanying drawings. It is intended, however, that unless particularly specified, dimensions, materials, shapes, relative positions and the like of components described in the embodiments shall be interpreted as illustrative only and not intended to limit the scope of the present invention which is defined by the claims.

**[0042]** For instance, an expression of relative or absolute arrangement such as "in a direction", "along a direction", "parallel", "orthogonal", "centered", "concentric" and "coaxial" shall not be construed as indicating only the arrangement in a strict literal sense, but also includes a state where the arrangement is relatively displaced by a tolerance, or by an angle or a distance whereby it is possible to achieve the same function.

**[0043]** For instance, an expression of an equal state such as "same" "equal" and "uniform" shall not be construed as indicating only the state in which the feature is strictly equal, but also includes a state in which there is a tolerance or a difference that can still achieve the same function.

**[0044]** Further, for instance, an expression of a shape such as a rectangular shape or a cylindrical shape shall not be construed as only the geometrically strict shape, but also includes a shape with unevenness or chamfered corners within the range in which the same effect can be achieved.

**[0045]** On the other hand, an expression such as "comprise", "include", "have", "contain" and "constitute" are not intended to be exclusive of other components.

**[0046]** FIG. 1 is a schematic diagram of a configuration example of a wind turbine power generating apparatus according to an embodiment. FIG. 2 is a perspective view of a wind turbine blade according to an embodiment. FIGs. 3A and 3B are cross-sectional views taken along lines A-A and B-B in FIG. 2, respectively. FIG. 4 is a planar view of a tip side of a wind turbine blade according to an embodiment.

**[0047]** As depicted in FIG. 1, according to at least one embodiment of the present invention, the wind turbine power generating apparatus (hereinafter, referred to as wind turbine) 1 includes at least one wind turbine blade 2, a hub 3 to which the wind turbine blade 2 is mounted, a nacelle 4 supporting a rotor including the wind turbine blade 2 and the hub 3, and a tower 5 which supports the nacelle 4 revolvably. Rotation of the rotor is inputted into a non-depicted generator, and the generator thereby generates electric power.

**[0048]** The tower 5 is disposed on ocean if the wind turbine power generating apparatus is an offshore type, and on a foundation on land if the wind turbine power generating apparatus is an onshore type.

**[0049]** As depicted in FIG. 2, the wind turbine blade 2 according to an embodiment includes a blade body portion 20 extending from a blade root portion 2A toward a blade tip portion 2B, and a metal receptor 50 including the blade tip portion 2B of the wind turbine blade 2.

**[0050]** As depicted in FIG. 2, the blade body portion 20 includes the blade root portion 2A to be attached to the hub 3 of the wind turbine 1, the blade tip portion 2B positioned farthest from the hub 3, and an airfoil portion 2C (blade center portion) extending between the blade root portion 2A and the blade tip portion 2B in the blade spanwise direction. Further, the blade body

portion 20 has a leading edge 21 and a trailing edge 23 extending from the blade root portion 2A to the blade tip portion 2B. The contour of the blade body portion 20 is defined by a suction surface 25 and a pressure surface 27 defined across the leading edge 21 and the trailing edge 23 (see FIGs. 2 and 3).

**[0051]** In the present specification, "blade spanwise direction" refers to a direction connecting the blade root portion 2A and the blade tip portion 2B, and "chordwise direction (blade chordwise direction)" refers to a direction along a line (chord) connecting the leading edge 21 and the trailing edge 23 of the blade body portion 20. Further, "blade-thickness direction (flap direction)" refers to a direction substantially orthogonal to the chordwise direction connecting the leading edge 21 and the trailing edge 23, that is, a direction connecting the suction side and the pressure side of the blade body portion 20. (see FIGs. 2 and 3). Furthermore, "blade root portion" refers to a cylindrical portion of the wind turbine blade 2, which has a substantially circular cross section, extending in the blade spanwise directional range of 5m, for instance, from the end surface on the side of the blade root portion 2A of the blade body portion 20 of the wind turbine blade 2 (typically, the range of 1m to 3m from the end surface).

**[0052]** In some embodiments, the blade body portion 20 is at least partially made of fiber-reinforced plastic (FRP). In some embodiments, as depicted in FIGs. 3 and 4, the wind turbine blade 2 may include a metal foil 32 extending along the blade spanwise direction toward the blade root portion 2A from a joint portion 10 between the metal receptor 50 and an end portion of the blade body portion 20. The metal foil 32 may be configured to guide lightning current from the metal receptor 50 toward the blade root portion 2A and may have a function of a down-conductor. In an embodiment, the metal foil 32 is electrically connected to another down-conductor passing through the blade root portion 2A, the hub 3, the nacelle 4, and the tower 5. When the metal receptor 50 receives lightning, the metal foil 32 may guide lightning current from the metal receptor 50 to an earth terminal mounted to the tower 5, via the other down-conductor.

**[0053]** As depicted in FIG. 2, in some embodiments, the blade body portion 20 is connected to the metal receptor 50 while being positioned on a side of the metal receptor 50 that is closer to the blade root portion 2A. In some embodiments, the blade body portion 20 has a hollow structure that forms an airfoil shape in the blade-tip region of the wind turbine blade 2, together with the metal receptor 50, in the joint region between the blade body portion 20 and the metal receptor 50.

**[0054]** Specifically, as shown in FIG. 3A, at the blade root portion 2A in an embodiment, the wind turbine blade 2 comprises an inner blade-root reinforcement member 22, an airfoil forming member 24 with spar caps 26, an insulation layer 28, an outer blade-root reinforcement member 30, the metal foil 32, and a protection layer 34, arranged in this order from inside to outside in the thickness direction. Furthermore, in an embodiment, as shown in FIG. 3B, at the airfoil portion 2C, the wind turbine blade 2 comprises the airfoil forming member 24 with the spar caps 26, the insulation layer 28, the metal foil 32, and the protection layer 34, arranged in this order from inside to outside in the thickness direction.

**[0055]** In FIGs. 3A and 3B, the thickness and size of each member is depicted differently from the actual measurement of a wind turbine blade to simplify the explanation.

**[0056]** In some embodiments, the blade body portion 20 may be configured such that the suction surface 25 and the pressure surface 27 are joined to each other to form a single piece along the edge portion of each of the leading edge 21 and the trailing edge 23, as depicted in FIGs. 2, 3A and 3B. In some embodiments, in the wind turbine blade 2, the suction surface 25 and the pressure surface 27 may be coupled to each other via at least one shear web 36 (beam member) in the blade spanwise direction at respective inner surface sides. The shear web 36 may be disposed continuously from the blade root portion 2A to the vicinity of the end portion of the blade body portion 20. With the shear web 36 provided also on the tip side of the blade body portion 20, it is possible to support the loads increased by the metal receptor 50 with the shear web 36. The end portion of the blade body portion 20 is an end portion of the blade body portion 20 on the side of the blade tip portion 2B, having the metal receptor 50 connected thereto.

**[0057]** In some embodiments, the insulation layer 28 is interposed between the sparcaps 26 and the metal foil 32, and the insulation layer 28 insulates the sparcaps 26 from the metal foil 32. Accordingly, when the metal receptor 50 receives lightning, it is possible to prevent a strong lightning current from running to the sparcaps 26 from the metal foil 32 to damage the sparcaps 26.

**[0058]** As described above, the metal foil 32 extends along the blade spanwise direction toward the blade root portion 2A from the joint portion 10 between the metal receptor 50 and the end portion of the blade body portion 20. For instance, the metal foil 32 may have a sheet shape or a mesh shape, and may be made of copper or copper alloy.

**[0059]** As depicted in FIGs. 4 to 11 (Figs 5 to 8 are not according to the invention as claimed but show examples serving to explain aspects of the invention), in some embodiments, when the wind turbine blade 2 is seen in the blade-thickness direction, the tangent 72 to a joint line 70 between the metal receptor 50 and the blade body portion 20 at an intersection P between the joint line 70 and a side of the leading edge 21 of the wind turbine blade 2 is inclined from the chordwise direction of the wind turbine blade 2 (inclination angle  $\theta$ ).

**[0060]** With the above configuration, the joint surface between the metal receptor 50 and the blade body portion 20 having a hollow structure is inclined from the chordwise direction, and thereby the collision angle of a foreign substance F (e.g. raindrops, dusts) formed with the leading edge 21 of the wind turbine blade 2 is not the same as the tangent direction of the joint surface. Accordingly, it is possible to mitigate concentration of shock on the joint portion upon collision of a foreign substance with the wind turbine blade 2, and thereby to suppress erosion on the joint surface and erosion damage to the wind turbine blade 2. It is possible to avoid perpendicular collision between the foreign substance F in the air and the leading edge 21 of the joint line 70 of the wind turbine blade 2, and thereby it is possible to mitigate concentration

of shock on the joint portion 10 upon collision of the foreign substance F with the wind turbine blade 2, and to reduce erosion damage to the wind turbine blade 2.

**[0061]** Suppressing erosion as described above on the joint surface between the metal receptor 50 and the blade body portion 20 is effective particularly in a case where the blade body portion 20 has a "hollow structure" as in some embodiments. That is, in a case where the blade body portion 20 has a hollow structure, development of erosion on the joint surface between the metal receptor 50 and the blade body portion 20 may lead to formation of a communication path that connects inside and outside of the wind turbine blade 2, which may let through foreign substances into the inside (hollow section) of the blade body portion 20, and thus it is technically beneficial to be able to suppress erosion on the joint surface as described above.

**[0062]** In some embodiments, for instance, as depicted in FIG. 5 which is not according to the invention as claimed but shows an example serving to explain aspects of the invention, the joint line 70 may have a linear shape so that intersection Q between the joint line 70 and the trailing edge 23 of the wind turbine blade 2 is at the same position as intersection R between the tangent 72 and the trailing edge 23 of the wind turbine blade 2, when seen in the blade-thickness direction of the wind turbine blade 2. In some embodiments, for instance, as depicted in FIG. 6 which is not according to the invention as claimed but shows an example serving to explain aspects of the invention, the joint line 70 may have a curved shape so that intersection Q between the joint line 70 and the trailing edge 23 of the wind turbine blade 2 is positioned closer to the blade tip 2B than intersection R between the tangent 72 and the trailing edge 23 of the wind turbine blade 2, when seen in the blade-thickness direction of the wind turbine blade 2. Furthermore, in some embodiments, for instance, as depicted in FIG. 7 which is not according to the invention as claimed but shows an example serving to explain aspects of the invention, the joint line 70 may have a bent shape so that intersection Q between the joint line 70 and the trailing edge 23 of the wind turbine blade 2 is positioned closer to the blade tip 2B than intersection R between the tangent 72 and the trailing edge 23 of the wind turbine blade 2.

**[0063]** With the above configuration, the joint line 70 between the metal receptor 50 and the blade body portion 20 having a hollow structure may have a non-linear shape from the leading edge 21 to the trailing edge 23 within a range where intersection Q between the joint line 70 and the trailing edge 23 of the wind turbine blade 2 is closer to the blade tip portion 2B than intersection R between the tangent 72 and the trailing edge 23 of the wind turbine blade 2. Accordingly, it is possible to improve the design flexibility of the shape of the joint portion 10 between the metal receptor 50 and the blade body portion 20, and thereby it is possible to select a shape for the metal receptor 50 from among a variety of shapes to reduce erosion damage to the wind turbine blade 2 more suitably with the receptor 50.

**[0064]** In the examples depicted in FIGs. 5 to 7, any one of intersection P between the joint line 70 and the leading edge 21 or intersection Q between the joint line 70 and the trailing edge 23 may be positioned closer to the blade tip portion 2B. In other words, intersection P may be

disposed closer to the blade tip portion 2B than intersection Q, or intersection Q may be disposed closer to the blade tip portion 2B than intersection P. Further, intersection R between the tangent 72 and the trailing edge 23 may be disposed closer to the blade root portion 2A than a chord passing through intersection P, or may be closer to the tip portion 2B than the chord.

**[0065]** In the invention, as depicted in FIG. 4, 9, or 10, the tangent 72 is inclined from the chordwise direction so that the tangent 72 extends closer to the blade tip portion 2B with distance from the leading edge 21 toward the trailing edge 23 of the wind turbine blade 2. With this configuration, it is the metal receptor 50 that is disposed on the side of the leading edge 21 of the joint line 70, and thus it is possible to effectively suppress erosion on the joint line 70.

**[0066]** In some embodiments, the length  $L_1$  of the metal receptor 50 along the blade spanwise direction may be at least 0.1% and not more than 0.9% of the blade length  $L$  of the wind turbine blade 2 ( $0.001L \leq L_1 \leq 0.009L$ ), or maybe at least 50mm and not more than 700mm ( $50\text{mm} \leq L_1 \leq 700\text{mm}$ ) (see FIGs. 2 and 4). Accordingly, with the length of the metal receptor 50 being at least 0.1% of the blade length, or at least 50mm, the metal receptor 50 can exert a high lightning-protection performance. Furthermore, with the length of the metal receptor 50 being not more than 0.9% of the blade length, or not more than 700mm, it is possible to suppress a weight increase of the wind turbine blade 2 associated with a size increase of the metal receptor 50.

**[0067]** In some embodiments, the width  $W_1$  of the metal receptor 50 along the chordwise direction may be at least 0.25% and not more than 0.9% of the blade length  $L$  of the wind turbine blade 2 ( $0.0025L \leq W_1 \leq 0.009L$ ), or maybe at least 200mm and not more than 700mm ( $200\text{mm} \leq W_1 \leq 700\text{mm}$ ) (see FIGs. 2 and 4). Accordingly, with the width of the metal receptor 50 being at least 0.25% of the blade length, or at least 200mm, the metal receptor 50 can exert a high lightning-protection performance. Furthermore, with the width of the metal receptor 50 being not more than 0.9% of the blade length or not more than 700mm, it is possible to suppress a weight increase of the wind turbine blade 2 associated with a size increase of the metal receptor 50.

**[0068]** In some embodiments, the joint line 70 may have a curved shape having a curvature radius  $R_1$  of not more than 0.009L ( $R_1 \leq 0.009L$ ), provided that  $L$  is the blade length of the wind turbine blade 2 (see FIGs. 2, 8, and 9). With this configuration, the joint line 70 has a curved shape, which makes it possible to suppress weight concentration of the metal receptor 50 toward the leading edge 21 or toward the trailing edge 23, and to ensure a sufficient inclination angle between the chordwise direction and the tangent 72 to the joint line 70 at intersection P between the leading edge 21 and the joint line 70, thus suppressing erosion at the joint line 70 effectively.

**[0069]** As depicted in FIG. 11, in some embodiments, the wind turbine blade 2 may further include a first anti-erosion layer 80 that covers at least a part of the outer surface of the blade body portion 20.

**[0070]** In some embodiments, the first anti-erosion layer 80 is a protection material having an anti-wear (anti-erosion) property, and may be embodied as a tape, paint, coating, or the like. The first anti-erosion layer 80 is applied or attached to the surface of the blade body portion 20 to protect the blade body portion 20 from collision with the foreign substance F in the air. In some embodiments, the first anti-erosion layer 80 may be a polyurethane coating material (e.g. 3M Wind Blade Protection Coating W4600 of 3M (trademark), a polyurethane coating material of BASF), or a tape with such a polyurethane coating material applied thereto.

**[0071]** With this configuration, the first anti-erosion layer 80 is further provided to cover at least a part of the outer surface of the blade body portion 20, and thereby it is possible to reduce erosion damage to the wind turbine blade 2 more effectively.

**[0072]** As depicted in FIG. 11, in some embodiments, the wind turbine blade 2 may further include a second anti-erosion layer 82 that covers at least a portion of the joint line 70 between the metal receptor 50 and the blade body portion 20, the portion being disposed on the side of the leading edge 21. With the second anti-erosion layer 82 additionally provided, it is possible to cover the portion of the joint line 70 between the metal receptor 50 and the blade body portion 20 on the side of the leading edge 21. Accordingly, it is possible to suppress erosion on the joint line 70 even more effectively.

**[0073]** As depicted in FIG. 12, in some embodiments, the wind turbine blade 2 may further include a lightning-current transmission part 90 which includes at least one of: the metal foil 32 connected to the metal receptor 50 and extending from the connecting section to the metal receptor 50 toward the blade root portion 2A of the wind turbine blade 2; or a down-conductor 8. With this configuration, the lightning-current transmission part 90 including at least one of the metal foil 32 or the down-conductor 8 is provided, and thereby it is possible to exert the lightning-protection performance more reliably while achieving the above described effect to suppress erosion damage to the wind turbine blade 2.

**[0074]** A configuration example of the metal receptor 50 will now be described with reference to FIG. 13. FIG. 13 is a cross-sectional view of a tip side of a wind turbine blade according to an embodiment.

**[0075]** First recessed portions 54A, 54B, and second recessed portions 56A, 56B are formed on an outer surface of the end portion of the metal receptor 50. The first recessed portions 54A, 54B and the second recessed portions 56A, 56B are disposed adjacent to each other in the blade-spanwise direction via steps 55A, 55B, respectively. The first recessed portions 54A, 54B are disposed closer to the blade root portion 2A, and the second recessed portions 56A, 56B are disposed closer to the blade tip portion 2B. The first recessed portions 54A, 54B are formed to be shallower than the second recessed portions 56A, 56B. Further, bolt holes 57A1, 57B1 are formed on the first recessed portions, and bolt holes 57A2, 57B2 are formed on the second recessed portions. While the first recessed portions 54A, 54B are disposed adjacent to the second recessed portions 56A, 56B in the blade spanwise direction in the present

configuration, the configuration of the recessed portions is not limited to this. For instance, the first recessed portions 54A, 54B, and the second recessed portions 56A, 56B may be disposed adjacently in the blade width direction.

**[0076]** In some embodiments, the metal receptor 50 may be formed of copper or copper alloy. Accordingly, with the metal receptor 50 including copper or copper alloy having a high conductivity, it is possible to exert the lightning-protection performance more reliably while achieving the above described effect to suppress erosion damage to the wind turbine blade 2.

**[0077]** In some embodiments, the blade body portion 20 may include a FRP shell 29 connected to the metal receptor 50 in a state of overlapping the metal receptor 50. For instance, as depicted in FIG. 13, at the joint portion 10 between the blade body portion 20 and the metal receptor 50, a fiber-reinforced plastic 24A (FRP) is fastened to the metal receptor 50 in a state where the fiber-reinforced plastic 24A and the metal receptor 50 are at least overlapping, and an end portion of the metal foil 32 is electrically connected to the metal receptor 50. Further, as depicted in FIG. 13, the metal foil 32 is interposed between a first metal plate 40 and a second metal plate 42 at the joint portion 10. The first metal plate 40 and the second metal plate 42 may extend from the joint portion 10 to a midway position of the blade body portion 20.

**[0078]** Furthermore, the first recessed portions 54A, 54B are engaged with the fiber-reinforced plastic 24A that forms the end portion of the blade body portion 20, the second metal plate 42, the metal foil 32 and the first metal plate 40, which are fastened together with bolts 46 screwed into the bolt holes 57A1, 57A2. Accordingly, the blade body portion 20 and the metal receptor 50 are connected. Since the fiber-reinforced plastic 24A and the metal receptor 50 are fastened to each other in a state of at least overlapping with each other, it is possible to achieve a greater contact area between the fiber-reinforced plastic 24A and the metal receptor 50 at the joint portion 10, which makes it possible to maintain a high connection strength that can bear the bending moment of the wind turbine blade 2 generated by wind loads that the wind turbine blade 2 receives, for instance. Furthermore, the first recessed portions 54A, 54B and the fiber-reinforced plastic 24A make surface-contact with each other, which makes it possible to ensure a high connection strength between the blade body portion 20 and the metal receptor 50.

**[0079]** Furthermore, the second recessed portions 56A, 56B are engaged with the second metal plate 42, the metal foil 32 and the first metal plate 40, which are fastened together with bolts 48 screwed into the bolt holes 57A2, 57B2. Accordingly, the metal foil 32 is connected to the metal receptor 50 via the second metal plate 42. Thus, the metal foil 32 and the metal receptor 50 that function as a down-conductor are electrically connected. Since the metal foil 32 is fastened while being overlapped with the metal receptor 50 via the second metal plate 42, the metal foil 32 and the metal foil 50 make electrical connect with each other via a larger electrical-connection area, and thereby it is possible to let lightning current received by the metal receptor 50 flow smoothly to the metal foil 32. Furthermore, the second recessed portions 56A, 56B and the second metal plate 42 make surface-contact with each other, which

makes it possible to ensure electrical connection between the metal foil 32 and the metal receptor 50 via the second metal plate 42. With the above configuration, it is possible to achieve the effect to suppress erosion damage to the wind turbine blade 2, mentioned in the above described embodiments, at the connection section between the metal receptor 50 and the FRP shell 29 of a hollow structure that is formed by the fiber-reinforced plastic 24A.

**[0080]** As depicted in FIG. 13, in some embodiments, the metal receptor 50 may include: a first portion 52A that forms the pressure surface 27 on the side of the blade tip portion 2B of the wind turbine blade 2; and a second portion 52B that forms the suction surface 25 on the side of the blade tip portion 2B of the wind turbine blade 2, the second portion 52B being fastened to the first portion 52A. In an embodiment, the first portion 52A of the metal receptor 50 may have a substantially symmetric shape with the second portion 52B. The first portion 52A has a butting surface 53A meeting a butting surface 53B of the second portion 52B, and is fastened to the second portion 52B. A plurality of bolt holes (not depicted) is formed on the butting surface 53A of the first portion 52A, and a plurality of bolt holes (not depicted) is formed on the butting surface 53B of the second portion 52B in positions corresponding to those of the bolt holes on the butting surface 53A. Accordingly, the first portion 52A and the second portion 52B are bolt-fastened while the butting surfaces 53A, 53B are meeting each other. With the metal receptor 50 having a halved shape as described above, it is possible to attach the metal plates 40, 42 and the metal foil 32, for instance, to the metal receptor 50 readily. With this configuration, the metal receptor 50 includes the first portion 52A forming the pressure surface 27 on the side of the blade tip portion 2B and the second portion 52B forming the suction surface 25 on the side of the blade tip portion 2B, and thereby it is possible to facilitate assembly and maintenance works for the blade body portion 20 while achieving the effect to suppress erosion damage to the wind turbine blade 2 as described in the above embodiments.

**[0081]** As depicted in FIG. 13, in some embodiments, the metal receptor 50 may have a cavity 51 formed therein. With the above configuration, the metal receptor 50 has the cavity 51 formed therein, and thereby it is possible to suppress a weight increase of the metal receptor 50 while suppressing erosion on the joint line 70.

**[0082]** As depicted in FIG. 13 for instance, in some embodiments, the metal receptor 50 may have a cavity 51 formed therein and a drain hole 59 communicating with the cavity 51. With this configuration, the metal receptor 50 has the drain hole 59 communicating with the cavity 51 formed inside the metal receptor 50, and thereby it is possible to discharge a foreign substance F like a raindrop that accumulates inside the cavity 51 to outside through the drain hole 59, and thus to suppress erosion damage to the wind turbine blade 2 effectively.

**[0083]** As depicted in FIG. 13, for instance, the second portion 52B has a cavity (recessed portion) 51 that forms an empty section inside the metal receptor 50 in combination with the recessed portion of the first portion 52A, when assembled with the first portion 52A. Further, a drain hole 59 may be provided to be in communication with the cavity 51. The drain 59 is disposed on the tip of the metal receptor 50. If the cavity 51 is divided into a plurality of cavities by the butting surface 53B, grooves may be formed on the butting surface 53B so that the

plurality of cavities 51 communicate with each other.

**[0084]** With this configuration, the foreign substance F like a raindrop gathered inside the metal receptor 50 can be smoothly discharged outside through the drain hole 59 from the empty sections formed by the cavities 51.

**[0085]** Further, the first portion 52A may have the same configuration as the second portion 52B.

**[0086]** As described above, according to the above described embodiments, it is possible to provide the wind turbine 1 having the wind turbine blade 2 whereby it is possible to suppress erosion on the joint line 70 effectively.

### Description of Reference Numerals

#### **[0087]**

- 1 Wind turbine (wind turbine power generating apparatus)
- 2 Wind turbine blade
- 2A Blade root portion
- 2B Blade tip portion
- 2C Airfoil portion
- 3 Hub
- 4 Nacelle
- 5 Tower
- 8 Down-conductor
- 10 Joint portion
- 20 Blade body portion
- 21 Leading edge
- 22 Inner blade-root reinforcement member

- 23 Trailing edge
- 24 Airfoil forming member
- 24A Fiber-reinforced plastic
- 25 Suction surface
- 26 Sparcap
- 27 Pressure surface
- 28 Insulation layer
- 29 FRP shell
- 30 Outer blade-root reinforcement member
- 32 Metal foil
- 34 Protection layer
- 36 Shear web
- 40 First metal plate
- 42 Second metal plate
- 46, 48 Bolt
- 50 Metal receptor
- 51 Cavity
- 52A First portion
- 52B Second portion
- 53A, 53B Butting surface
- 54A, 54B First recessed portion
- 55A, 55B

Step  
56A, 56B  
    Second recessed portion  
57A1, 57A2, 57B1, 57B2  
    Bolt hole  
59  
    Drain hole  
70  
    Joint line  
72  
    Tangent  
80  
    First anti-erosion layer  
82  
    Second anti-erosion layer  
90  
    Lightning-current transmission part  
F  
    Foreign substance  
P, Q, R  
    Intersection

## REFERENCES CITED IN THE DESCRIPTION

Cited references

This list of references cited by the applicant is for the reader's convenience only. It does not form part of the European patent document. Even though great care has been taken in compiling the references, errors or omissions cannot be excluded and the EPO disclaims all liability in this regard.

**Patent documents cited in the description**

- [EP2226497A \[0002\]](#)
- [GB2527035A \[0003\]](#)
- [JP5730408B \[0004\]](#)

**Patentkrav****1.** Vindmøllevinge (2), omfattende:

et vingelegemeafsnit (20) som strækker sig fra et vingerodafsnit (2A) mod et vingespidsafsnit (2B) i en spændevidderetning af en vinge, hvor  
5 vingelegemeafsnittet (20) har en forkant (21) og en bagkant (23), som strækker sig fra vingerodafsnittet (2A) til vingespidsafsnittet (2B) og en kordevisretning af en vinge er retningen langs en korde, som forbinder forkanten (21) og bagkanten (23); og  
10 en metalreceptor (50), som danner en vingespids af vindmøllevingen (2), hvor vingelegemeafsnittet (20) er forbundet til metalreceptoren (50) for at blive positioneret på en vingerodside af metalreceptoren (50), hvor vingelegemeafsnittet (20) har en hul struktur og danner en bæreplanform i et vingespidsområde af vindmøllevingen (2) med metalreceptoren (50) i et sammenføjningsområde til metalreceptoren (50),  
15 hvor, set i en vingetykkelsesretning af vindmøllevingen (2), som er vinkelret på både spændevidderetningen og kordevisretningen, en tangent (72) til en sammenføjningslinje (70) mellem metalreceptoren (50) og vingelegemeafsnittet (20) ved et skæringspunkt (P) mellem sammenføjningslinjen (70) og forkanten (21) af vindmøllevingen (2)  
20 hælder fra kordevisretningen af vindmøllevingen (2) for at komme tættere på vingespidsen med afstand til forkanten (21) mod bagkanten (23) af vindmøllevingen (2).

**2.** Vindmøllevingen (2) ifølge krav 1,

25 hvor, set i vingetykkelsesretningen af vindmøllevingen (2), er sammenføjningslinjen (70) buet eller bøjet, således at et skæringspunkt (Q) mellem sammenføjningslinjen (70) og bagkanten (23) af vindmøllevingen (2) er positioneret tættere på vingespidsen end et skæringspunkt (R) mellem tangenten (72) og bagkanten (23) af vindmøllevingen (2).

30

**3.** Vindmøllevingen (2) ifølge krav 1 eller 2,

hvor en længde af metalreceptoren (50) langs spændevidderetningen af vingen er mindst 0,1% og ikke mere end 0,9% af en vingelængde af vindmøllevingen (2),

eller mindst 50mm og ikke mere end 700mm.

**4.** Vindmøllevingen (2) ifølge et hvilket som helst af kravene 1 til 3, hvor en bredde af metalreceptoren (50) langs kordevisretningen er mindst 0,25% 5 og ikke mere end 0,9% af en vingelængde af vindmøllevingen (2), eller mindst 200mm og ikke mere end 700mm.

**5.** Vindmøllevingen (2) ifølge et hvilket som helst af kravene 1 til 4, hvor sammenføjningslinjen (70) har en krummet form med en krumningsradius 10 på ikke mere end  $0,009L$ , forudsat at  $L$  er en vingelængde af vindmøllevingen (2).

**6.** Vindmøllevingen (2) ifølge et hvilket som helst af kravene 1 til 5, yderligere omfattende et første erosionsbeskyttelseslag (80), som dækker mindst en del af en yderflade af vingelegemeafsnittet (20).

15

**7.** Vindmøllevingen (2) ifølge et hvilket som helst af kravene 1 til 6, yderligere omfattende et andet erosionsbeskyttelseslag (82), som dækker mindst en del af sammenføjningslinjen (70) mellem metalreceptoren (50) og vingelegemeafsnittet (20), idet afsnittet er anbragt på en side af forkanten (21).

20

**8.** Vindmøllevingen (2) ifølge et hvilket som helst af kravene 1 til 7, yderligere omfattende en lynstrømooverførselsdel (90), som inkluderer mindst en af: en metalfolie (32), som er forbundet til metalreceptoren (50), og som strækker sig fra et forbindelsesafsnit til metalreceptoren (50) mod vingerodafsnittet (2A) af 25 vindmøllevingen (2); eller en afleder (8).

**9.** Vindmøllevingen (2) ifølge et hvilket som helst af kravene 1 til 8, hvor vingelegemeafsnittet (20) inkluderer en fiberforstærket plastskal (29) forbundet til metalreceptoren (50), mens den overlapper metalreceptoren (50).

30

**10.** Vindmøllevingen (2) ifølge et hvilket som helst af kravene 1 til 8, hvor metalreceptoren (50) har et hulrum (51) inden i metalreceptoren (50).

**11.** Vindmøllevingen (2) ifølge krav 10, 35 hvor metalreceptoren (50) inkluderer et afløbshul (59), som er i forbindelse med

hulrummet (51).

**12.** Vindmøllevingen (2) ifølge et hvilket som helst af kravene 1 til 10, hvor metalreceptoren (50) inkluderer:

- 5 et første afsnit (52A) som danner en trykflade (27) på en side af vingspidsen af vindmøllevingen (2); og  
et andet afsnit (52B) som danner en sugeflade (25) på siden af vingspidsen af vindmøllevingen (2), idet det andet afsnit (52B) er fastgjort til det første afsnit (52A).

10

**13.** Vindmøllevingen (2) ifølge et hvilket som helst af kravene 1 til 12, hvor metalreceptoren (50) omfatter kobber eller kobberlegering.

**14.** Vindmøllestrømgenereringsapparat (1) omfattende vindmøllevingen (2) ifølge  
15 et hvilket som helst af kravene 1 til 13.

# DRAWINGS

FIG. 1

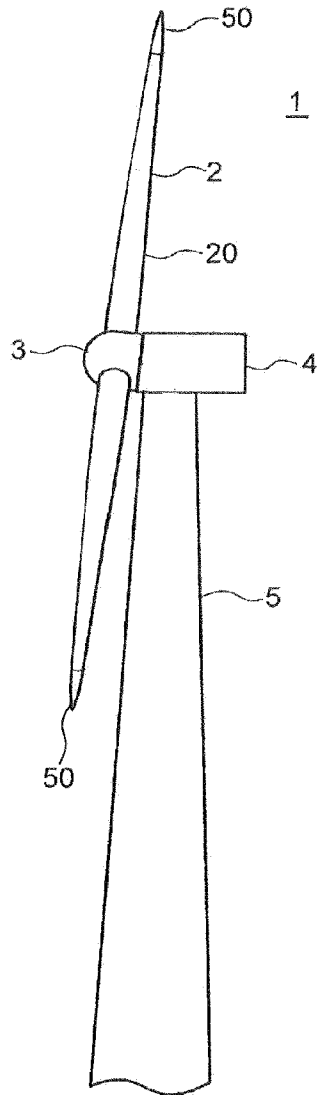
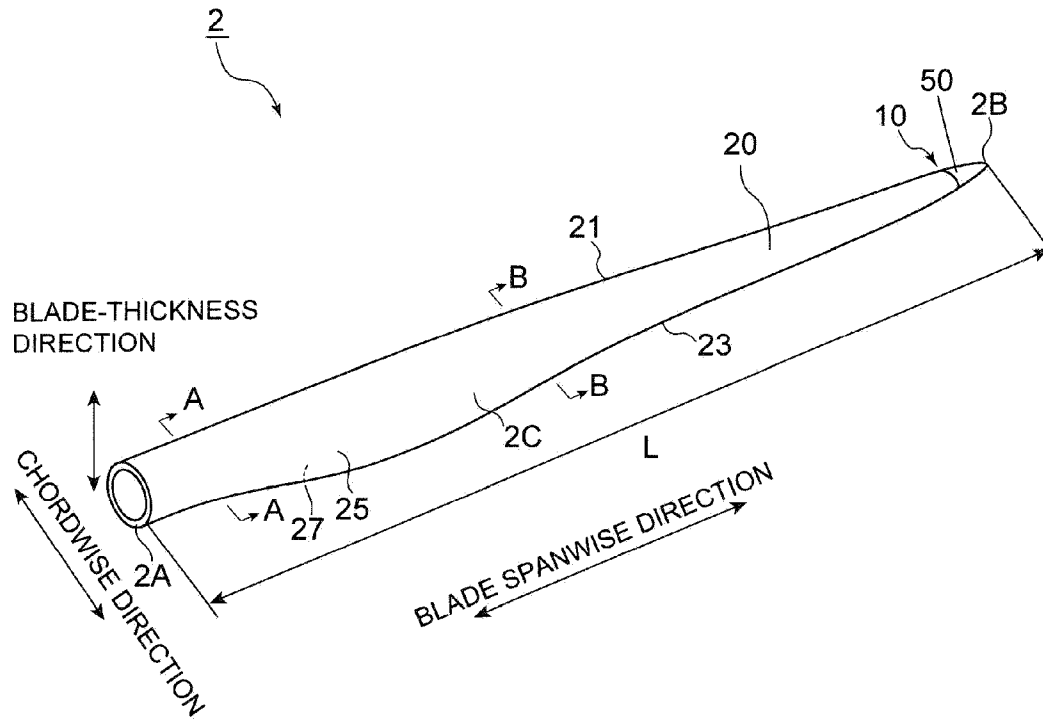

FIG. 2



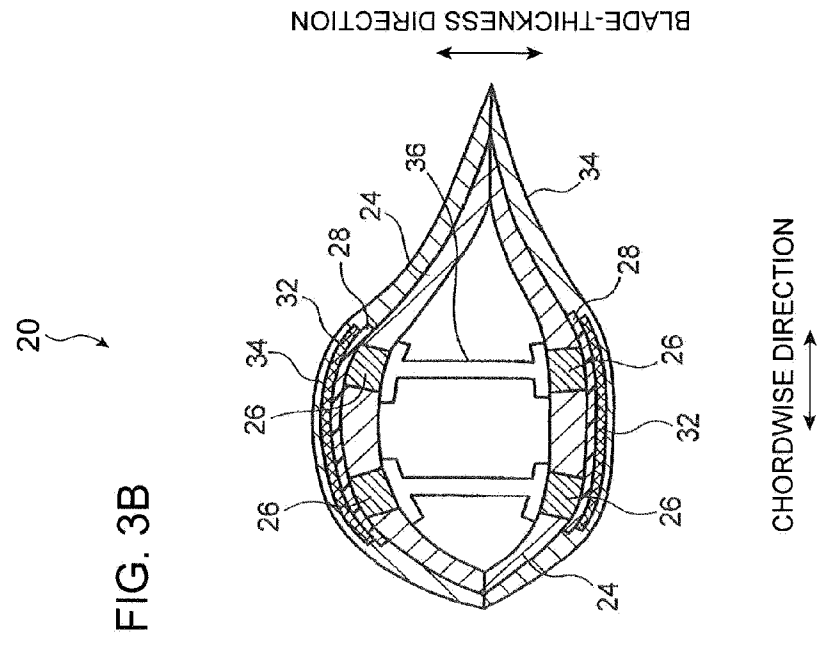
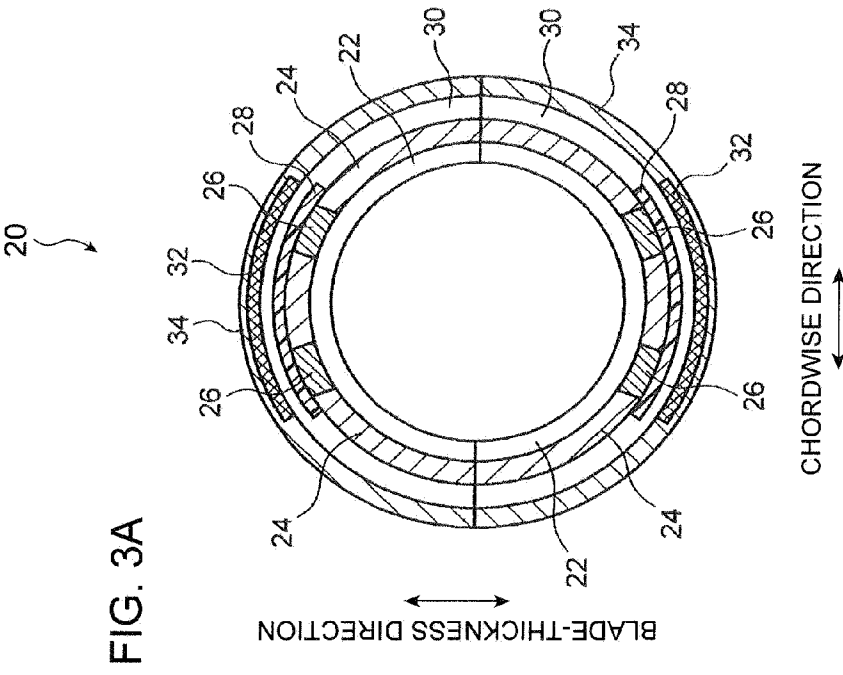

FIG. 4

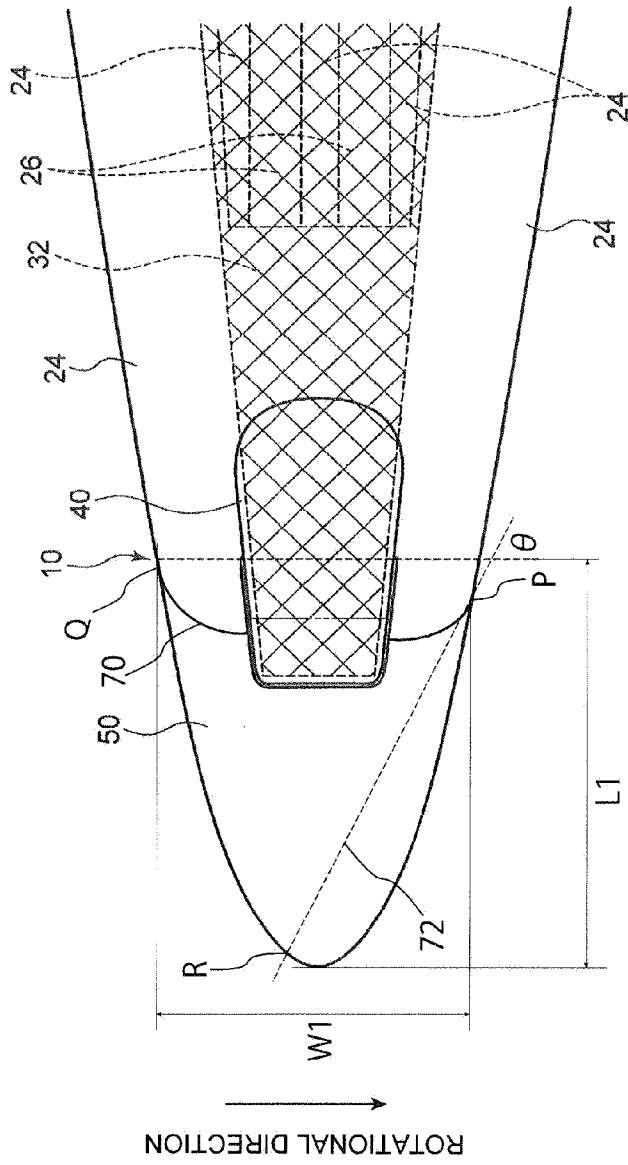

FIG. 5

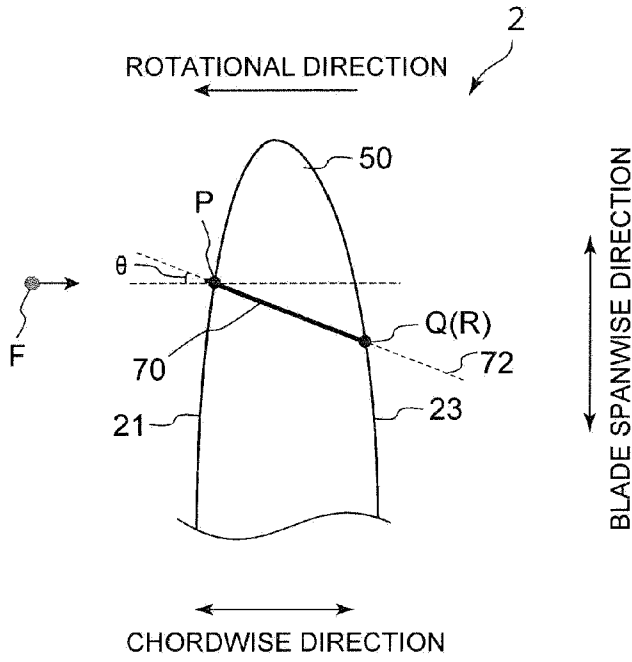

FIG. 6

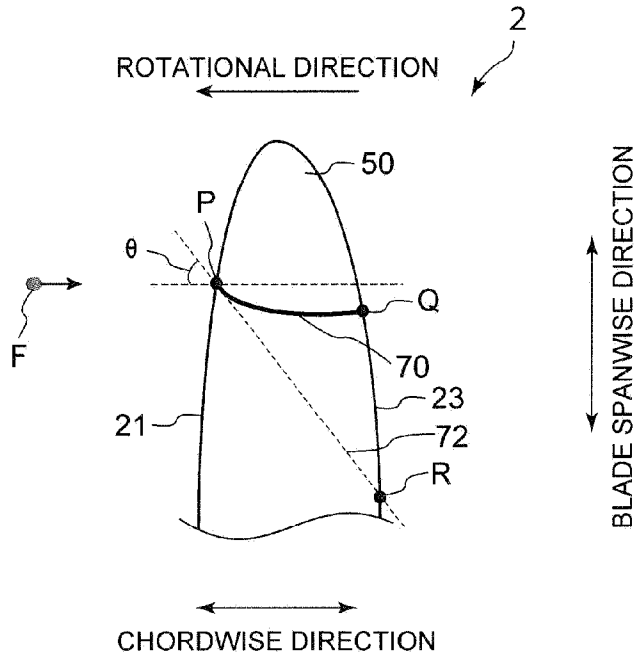

FIG. 7

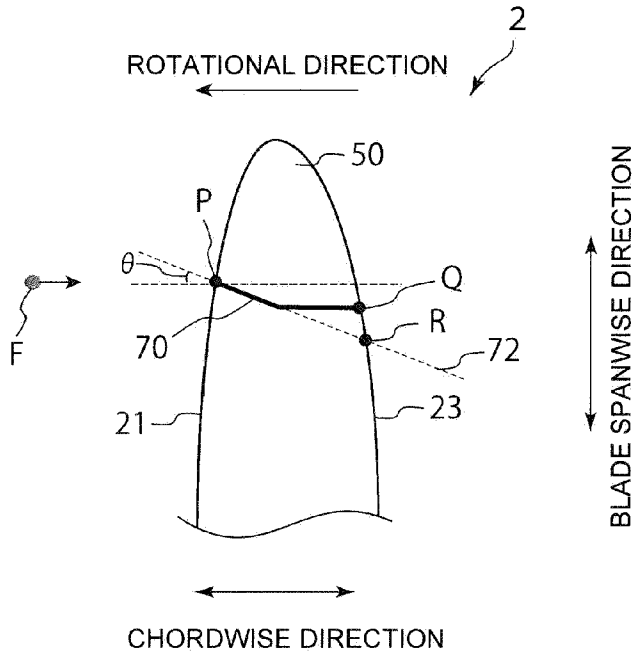

FIG. 8

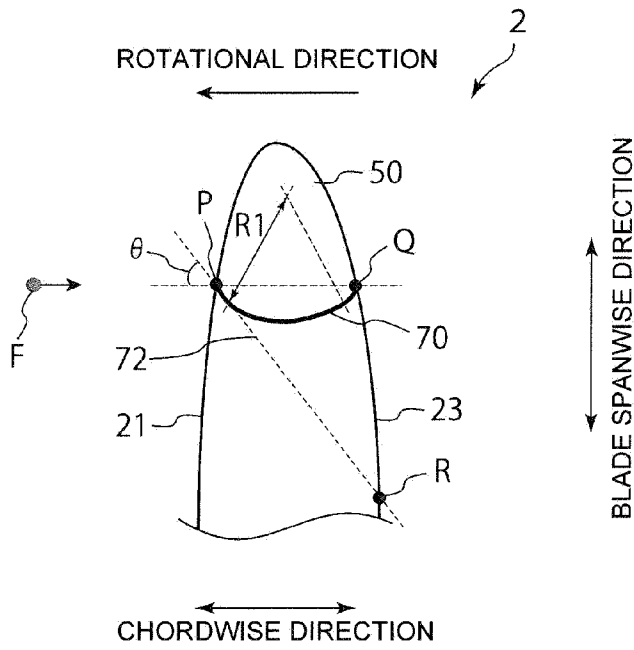

FIG. 9

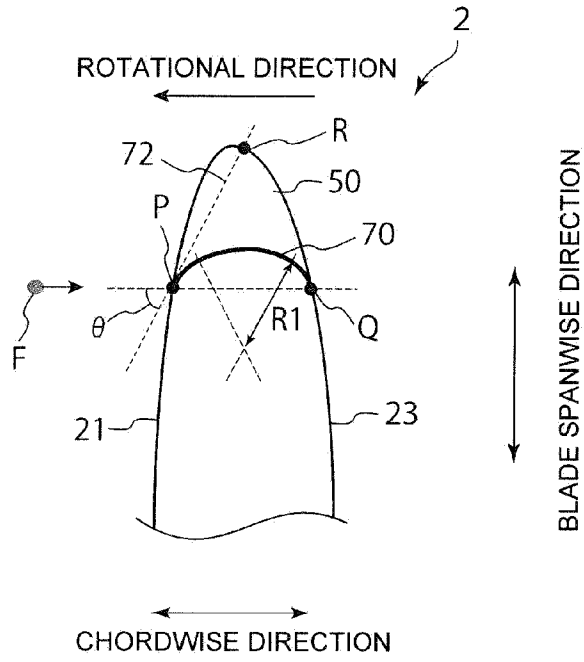

FIG. 10

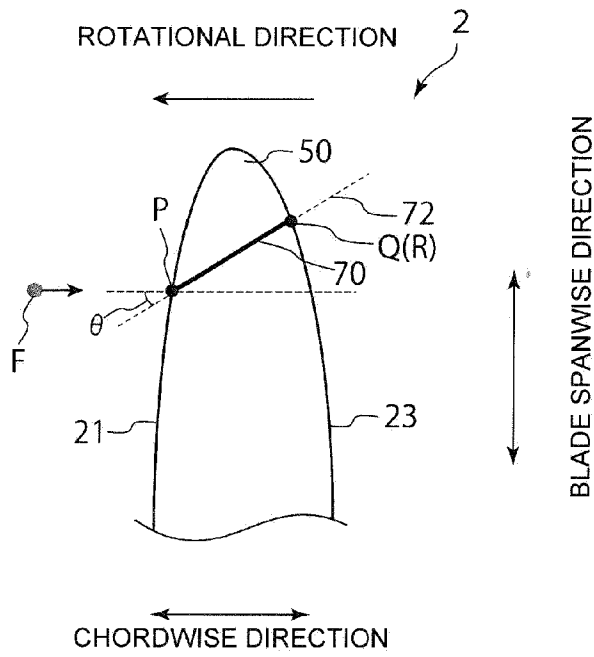

FIG. 11

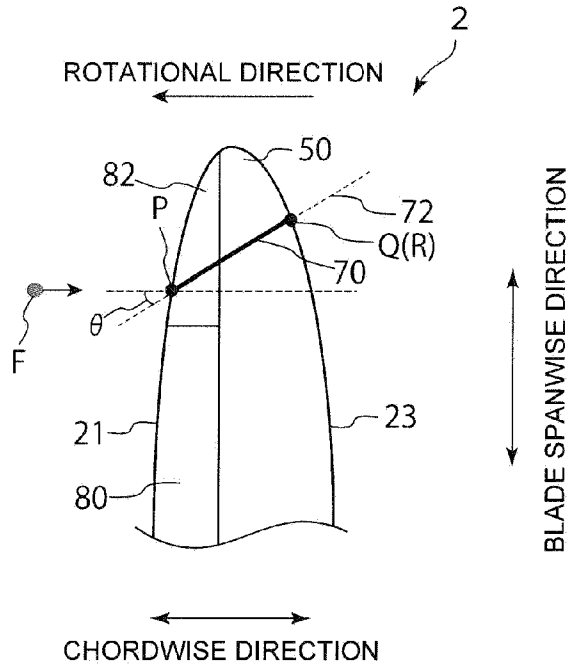

FIG. 12

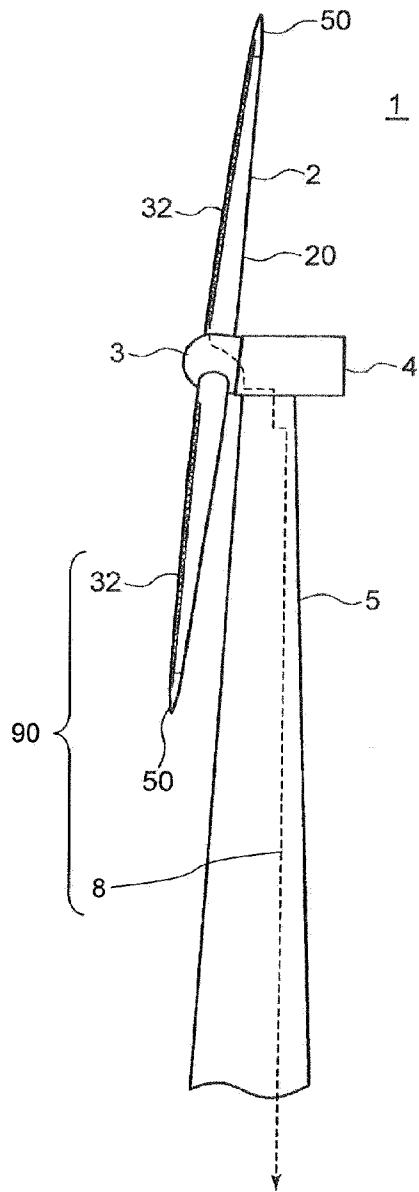

FIG. 13

