



(51) International Patent Classification:

A61B 18/12 (2006.01) A61B 17/32 (2006.01)
A61B 90/90 (2016.01) A61B 18/14 (2006.01)
H05K 5/00 (2006.01) A61B 34/20 (2016.01)
H05K 7/02 (2006.01)

16/562,212 05 September 2019 (05.09.2019) US

(71) Applicant: ETHICON LLC [US/US]; #475 Street C, Suite 401, Los Frailes Industrial Park, Guaynabo, PR 00969 (US).

(72) Inventors: HENDERSON, Joshua; 4545 Creek Road, Cincinnati, OH 45242 (US). MORGAN, Joshua, P.; 4545 Creek Road, Cincinnati, OH 45242 (US). CARROLL, Andrew, W.; 4545 Creek Road, Cincinnati, OH 45242 (US). ALDRIDGE, Jeffrey, L.; 4545 Creek Road, Cincinnati, OH 45242 (US). WIENER, Eitan, T.; 4545 Creek Road, Cincinnati, OH 45242 (US).

(21) International Application Number:

PCT/US2019/049982

(22) International Filing Date:

06 September 2019 (06.09.2019)

(25) Filing Language:

English

(26) Publication Language:

English

(74) Agent: SHIRTZ, Joseph F. et al.; Johnson & Johnson, One Johnson & Johnson Plaza, New Brunswick, New Jersey 08933 (US).

(30) Priority Data:

62/728,480 07 September 2018 (07.09.2018) US
62/826,587 29 March 2019 (29.03.2019) US
62/826,584 29 March 2019 (29.03.2019) US
62/826,592 29 March 2019 (29.03.2019) US
62/826,588 29 March 2019 (29.03.2019) US

(81) Designated States (unless otherwise indicated, for every kind of national protection available): AE, AG, AL, AM, AO, AT, AU, AZ, BA, BB, BG, BH, BN, BR, BW, BY, BZ, CA, CH, CL, CN, CO, CR, CU, CZ, DE, DJ, DK, DM, DO,

(54) Title: MODULAR SURGICAL ENERGY SYSTEM WITH MODULE POSITIONAL AWARENESS SENSING WITH VOLTAGE DETECTION

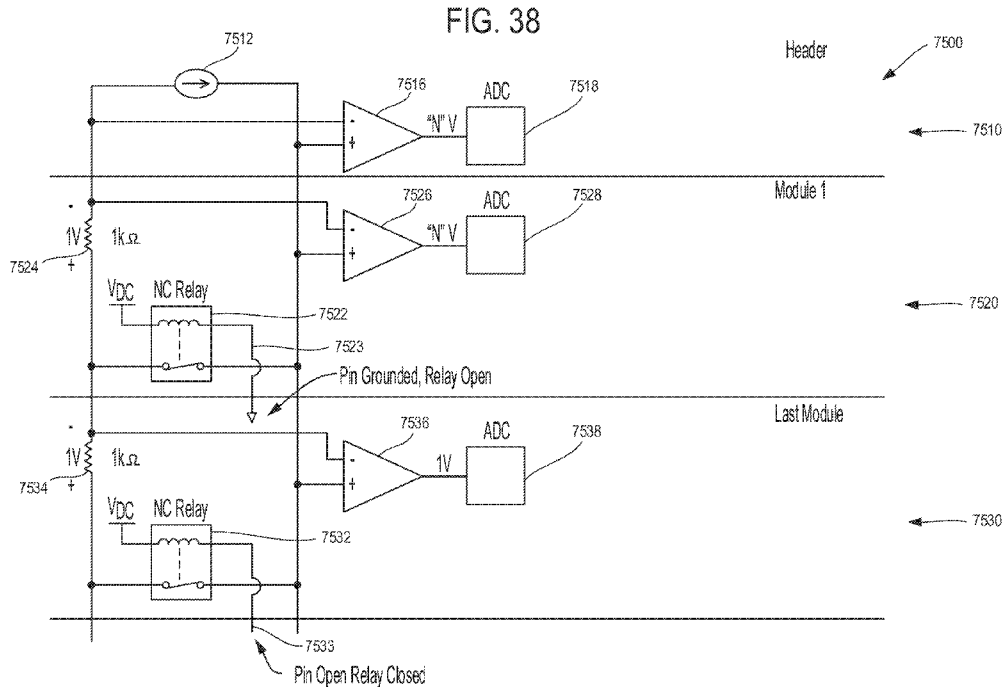

(57) Abstract: A modular surgical system is disclosed. The modular surgical system comprises a header module, a first surgical module, a second surgical module, and a module identification circuit. The second surgical module is arrangeable in a stack configuration with the header module and the first surgical module. The module identification circuit is configured to cause a pre-determined current to be transmitted to the first surgical module through the second surgical module in the stack configuration, detect a first voltage indicative of a first position of the first surgical module in the stack configuration, and detect a second voltage indicative of a second position of the second surgical module in the stack configuration. The second voltage is different than the first voltage.



DZ, EC, EE, EG, ES, FI, GB, GD, GE, GH, GM, GT, HN, HR, HU, ID, IL, IN, IR, IS, JO, JP, KE, KG, KH, KN, KP, KR, KW, KZ, LA, LC, LK, LR, LS, LU, LY, MA, MD, ME, MG, MK, MN, MW, MX, MY, MZ, NA, NG, NI, NO, NZ, OM, PA, PE, PG, PH, PL, PT, QA, RO, RS, RU, RW, SA, SC, SD, SE, SG, SK, SL, SM, ST, SV, SY, TH, TJ, TM, TN, TR, TT, TZ, UA, UG, US, UZ, VC, VN, ZA, ZM, ZW.

(84) Designated States (*unless otherwise indicated, for every kind of regional protection available*): ARIPO (BW, GH, GM, KE, LR, LS, MW, MZ, NA, RW, SD, SL, ST, SZ, TZ, UG, ZM, ZW), Eurasian (AM, AZ, BY, KG, KZ, RU, TJ, TM), European (AL, AT, BE, BG, CH, CY, CZ, DE, DK, EE, ES, FI, FR, GB, GR, HR, HU, IE, IS, IT, LT, LU, LV, MC, MK, MT, NL, NO, PL, PT, RO, RS, SE, SI, SK, SM, TR), OAPI (BF, BJ, CF, CG, CI, CM, GA, GN, GQ, GW, KM, ML, MR, NE, SN, TD, TG).

Declarations under Rule 4.17:

- *as to applicant's entitlement to apply for and be granted a patent (Rule 4.17(ii))*
- *as to the applicant's entitlement to claim the priority of the earlier application (Rule 4.17(iii))*

Published:

- *with international search report (Art. 21(3))*

TITLE

MODULAR SURGICAL ENERGY SYSTEM WITH MODULE POSITIONAL AWARENESS
SENSING WITH VOLTAGE DETECTION

CROSS-REFERENCE TO RELATED APPLICATIONS

[0001] The present application claims the benefit of U.S. Non-Provisional Patent Application Serial No. 16/562,212, titled MODULAR SURGICAL ENERGY SYSTEM WITH MODULE POSITIONAL AWARENESS SENSING WITH VOLTAGE DETECTION, filed September 5, 2019, the disclosure of which is herein incorporated by reference in its entirety.

[0002] The present application also claims the benefit of U.S. Provisional Patent Application Serial No. 62/826,584, titled MODULAR SURGICAL PLATFORM ELECTRICAL ARCHITECTURE, filed March 29, 2019, the disclosure of which is herein incorporated by reference in its entirety.

[0003] The present application also claims the benefit of U.S. Provisional Patent Application Serial No. 62/826,587, titled MODULAR ENERGY SYSTEM CONNECTIVITY, filed March 29, 2019, the disclosure of which is herein incorporated by reference in its entirety.

[0004] The present application also claims the benefit of U.S. Provisional Patent Application Serial No. 62/826,588, titled MODULAR ENERGY SYSTEM INSTRUMENT COMMUNICATION TECHNIQUES, filed March 29, 2019, the disclosure of which is herein incorporated by reference in its entirety.

[0005] The present application also claims the benefit of U.S. Provisional Patent Application Serial No. 62/826,592, titled MODULAR ENERGY DELIVERY SYSTEM, filed March 29, 2019, the disclosure of which is herein incorporated by reference in its entirety.

[0006] The present application also claims the benefit of U.S. Provisional Patent Application Serial No. 62/728,480, titled MODULAR ENERGY SYSTEM AND USER INTERFACE, filed September 7, 2018, the disclosure of which is herein incorporated by reference in its entirety.

BACKGROUND

[0007] The present disclosure relates to various surgical systems, including modular electrosurgical and/or ultrasonic surgical systems. Operating rooms (ORs) are in need of streamlined capital solutions because ORs are a tangled web of cords, devices, and people due to the number of different devices that are needed to complete each surgical procedure. This is a reality of every OR in every market throughout the globe. Capital equipment is a major offender in creating clutter within ORs because most capital equipment performs one

task or job, and each type of capital equipment requires unique techniques or methods to use and has a unique user interface. Accordingly, there are unmet consumer needs for capital equipment and other surgical technology to be consolidated in order to decrease the equipment footprint within the OR, streamline the equipment's interfaces, and improve surgical staff efficiency during a surgical procedure by reducing the number of devices that surgical staff members need to interact with.

SUMMARY

[0008] In one general aspect, a modular surgical system is disclosed. The modular surgical system comprises a header module, a first surgical module, a second surgical module, and a module identification circuit. The second surgical module is arrangeable in a stack configuration with the header module and the first surgical module. The module identification circuit is configured to cause a pre-determined current to be transmitted to the first surgical module through the second surgical module in the stack configuration, detect a first voltage indicative of a first position of the first surgical module in the stack configuration, and detect a second voltage indicative of a second position of the second surgical module in the stack configuration. The second voltage is different than the first voltage.

[0009] In another general aspect, a modular surgical system is disclosed. The modular surgical system comprises a header module, a first surgical module located at a first position with respect to the header module, and a second surgical module located at a second position with respect to the header module. The modular surgical system further comprises a module identification circuit configured to detect the presence of the first surgical module and the second surgical module, determine the first position of the first surgical module, and determine the second position of the second surgical module.

[0010] In another general aspect, a modular surgical system is disclosed. The modular surgical system comprises a header module, a first surgical module, and a second surgical module, wherein the header module, the first surgical module, and the second surgical module are arranged in a stack configuration. The modular surgical system further comprises a module identification circuit configured to detect the presence of the first surgical module and the second surgical module, determine a first position of the first surgical module within the stack configuration, and determine a second position of the second surgical module within the stack configuration, wherein the second position is different than the first position.

FIGURES

[0011] The various aspects described herein, both as to organization and methods of operation, together with further objects and advantages thereof, may best be understood by

reference to the following description, taken in conjunction with the accompanying drawings as follows.

[0012] FIG. 1 is a block diagram of a computer-implemented interactive surgical system, in accordance with at least one aspect of the present disclosure.

[0013] FIG. 2 is a surgical system being used to perform a surgical procedure in an operating room, in accordance with at least one aspect of the present disclosure.

[0014] FIG. 3 is a surgical hub paired with a visualization system, a robotic system, and an intelligent instrument, in accordance with at least one aspect of the present disclosure.

[0015] FIG. 4 is a partial perspective view of a surgical hub enclosure, and of a combo generator module slidably receivable in a drawer of the surgical hub enclosure, in accordance with at least one aspect of the present disclosure.

[0016] FIG. 5 is a perspective view of a combo generator module with bipolar, ultrasonic, and monopolar contacts and a smoke evacuation component, in accordance with at least one aspect of the present disclosure.

[0017] FIG. 6 illustrates individual power bus attachments for a plurality of lateral docking ports of a lateral modular housing configured to receive a plurality of modules, in accordance with at least one aspect of the present disclosure.

[0018] FIG. 7 illustrates a vertical modular housing configured to receive a plurality of modules, in accordance with at least one aspect of the present disclosure.

[0019] FIG. 8 illustrates a surgical data network comprising a modular communication hub configured to connect modular devices located in one or more operating theaters of a healthcare facility, or any room in a healthcare facility specially equipped for surgical operations, to the cloud, in accordance with at least one aspect of the present disclosure.

[0020] FIG. 9 illustrates a computer-implemented interactive surgical system, in accordance with at least one aspect of the present disclosure.

[0021] FIG. 10 illustrates a surgical hub comprising a plurality of modules coupled to the modular control tower, in accordance with at least one aspect of the present disclosure.

[0022] FIG. 11 illustrates one aspect of a Universal Serial Bus (USB) network hub device, in accordance with at least one aspect of the present disclosure.

[0023] FIG. 12 illustrates a logic diagram of a control system of a surgical instrument or tool, in accordance with at least one aspect of the present disclosure.

[0024] FIG. 13 illustrates a control circuit configured to control aspects of the surgical instrument or tool, in accordance with at least one aspect of the present disclosure.

[0025] FIG. 14 illustrates a combinational logic circuit configured to control aspects of the surgical instrument or tool, in accordance with at least one aspect of the present disclosure.

[0026] FIG. 15 illustrates a sequential logic circuit configured to control aspects of the surgical instrument or tool, in accordance with at least one aspect of the present disclosure.

[0027] FIG. 16 illustrates a surgical instrument or tool comprising a plurality of motors which can be activated to perform various functions, in accordance with at least one aspect of the present disclosure.

[0028] FIG. 17 is a schematic diagram of a robotic surgical instrument configured to operate a surgical tool described herein, in accordance with at least one aspect of the present disclosure.

[0029] FIG. 18 illustrates a block diagram of a surgical instrument programmed to control the distal translation of a displacement member, in accordance with at least one aspect of the present disclosure.

[0030] FIG. 19 is a schematic diagram of a surgical instrument configured to control various functions, in accordance with at least one aspect of the present disclosure.

[0031] FIG. 20 is a system configured to execute adaptive ultrasonic blade control algorithms in a surgical data network comprising a modular communication hub, in accordance with at least one aspect of the present disclosure.

[0032] FIG. 21 illustrates an example of a generator, in accordance with at least one aspect of the present disclosure.

[0033] FIG. 22 is a surgical system comprising a generator and various surgical instruments usable therewith, in accordance with at least one aspect of the present disclosure.

[0034] FIG. 23 is a diagram of a situationally aware surgical system, in accordance with at least one aspect of the present disclosure.

[0035] FIG. 24 is a diagram of various modules and other components that are combinable to customize modular energy systems, in accordance with at least one aspect of the present disclosure.

[0036] FIG. 25A is a first illustrative modular energy system configuration including a header module and a display screen that renders a graphical user interface (GUI) for relaying information regarding modules connected to the header module, in accordance with at least one aspect of the present disclosure.

[0037] FIG. 25B is the modular energy system shown in FIG. 25A mounted to a cart, in accordance with at least one aspect of the present disclosure.

[0038] FIG. 26A is a second illustrative modular energy system configuration including a header module, a display screen, an energy module, and an expanded energy module connected together and mounted to a cart, in accordance with at least one aspect of the present disclosure.

[0039] FIG. 26B is a third illustrative modular energy system configuration that is similar to the second configuration shown in FIG. 25A, except that the header module lacks a display screen, in accordance with at least one aspect of the present disclosure.

[0040] FIG. 27 is a fourth illustrative modular energy system configuration including a header module, a display screen, an energy module, an expanded energy module, and a technology module connected together and mounted to a cart, in accordance with at least one aspect of the present disclosure.

[0041] FIG. 28 is a fifth illustrative modular energy system configuration including a header module, a display screen, an energy module, an expanded energy module, a technology module, and a visualization module connected together and mounted to a cart, in accordance with at least one aspect of the present disclosure.

[0042] FIG. 29 is a diagram of a modular energy system including communicably connectable surgical platforms, in accordance with at least one aspect of the present disclosure.

[0043] FIG. 30 is a perspective view of a header module of a modular energy system including a user interface, in accordance with at least one aspect of the present disclosure.

[0044] FIG. 31 is a block diagram of a stand-alone hub configuration of a modular energy system, in accordance with at least one aspect of the present disclosure.

[0045] FIG. 32 is a block diagram of a hub configuration of a modular energy system integrated with a surgical control system, in accordance with at least one aspect of the present disclosure.

[0046] FIG. 33 is a block diagram of a user interface module coupled to a communications module of a modular energy system, in accordance with at least one aspect of the present disclosure.

[0047] FIG. 34 is a block diagram of an energy module of a modular energy system, in accordance with at least one aspect of the present disclosure.

[0048] FIGS. 35A and 35B illustrate a block diagram of an energy module coupled to a header module of a modular energy system, in accordance with at least one aspect of the present disclosure.

[0049] FIGS. 36A and 36B illustrate a block diagram of a header/user interface (UI) module of a modular energy system for a hub, such as the header module depicted in FIG. 33, in accordance with at least one aspect of the present disclosure.

[0050] FIG. 37 is a block diagram of an energy module for a hub, such as the energy module depicted in FIGS. 31-36B, in accordance with at least one aspect of the present disclosure.

[0051] FIG. 38 is a module identification circuit of a modular surgical system, in accordance with at least one aspect of the present disclosure.

[0052] FIG. 39 is a connection integrity circuit of a modular surgical system, in accordance with at least one aspect of the present disclosure.

[0053] FIG. 40 is a connection integrity circuit of a modular surgical system, in accordance with at least one aspect of the present disclosure.

[0054] Corresponding reference characters indicate corresponding parts throughout the several views. The exemplifications set out herein illustrate various embodiments of the invention, in one form, and such exemplifications are not to be construed as limiting the scope of the invention in any manner.

DESCRIPTION

[0055] Applicant of the present application owns the following U.S. Patent Applications filed concurrently herewith, the disclosure of each of which is herein incorporated by reference in its entirety:

- U.S. Patent Application Docket No. END9067USNP1/180679-1M, titled METHOD FOR CONSTRUCTING AND USING A MODULAR SURGICAL ENERGY SYSTEM WITH MULTIPLE DEVICES;
- U.S. Patent Application Docket No. END9069USNP1/180681-1M, titled METHOD FOR ENERGY DISTRIBUTION IN A SURGICAL MODULAR ENERGY SYSTEM;
- U.S. Patent Application Docket No. END9069USNP2/180681-2, titled SURGICAL MODULAR ENERGY SYSTEM WITH A SEGMENTED BACKPLANE;
- U.S. Patent Application Docket No. END9069USNP3/180681-3, titled SURGICAL MODULAR ENERGY SYSTEM WITH FOOTER MODULE;
- U.S. Patent Application Docket No. END9069USNP4/180681-4, titled POWER AND COMMUNICATION MITIGATION ARRANGEMENT FOR MODULAR SURGICAL ENERGY SYSTEM;
- U.S. Patent Application Docket No. END9069USNP5/180681-5, titled MODULAR SURGICAL ENERGY SYSTEM WITH MODULE POSITIONAL AWARENESS SENSING WITH VOLTAGE DETECTION;
- U.S. Patent Application Docket No. END9069USNP6/180681-6, titled MODULAR SURGICAL ENERGY SYSTEM WITH MODULE POSITIONAL AWARENESS SENSING WITH TIME COUNTER;
- U.S. Patent Application Docket No. END9069USNP7/180681-7, titled MODULAR SURGICAL ENERGY SYSTEM WITH MODULE POSITIONAL AWARENESS WITH DIGITAL LOGIC;
- U.S. Patent Application Docket No. END9068USNP1/180680-1M, titled METHOD FOR CONTROLLING AN ENERGY MODULE OUTPUT;
- U.S. Patent Application Docket No. END9068USNP2/180680-2, titled ENERGY MODULE FOR DRIVING MULTIPLE ENERGY MODALITIES;

- U.S. Patent Application Docket No. END9068USNP3/180680-3, titled GROUNDING ARRANGEMENT OF ENERGY MODULES;
- U.S. Patent Application Docket No. END9068USNP4/180680-4, titled BRIDGE CONNECTOR DESIGN TO CONNECT STACKED ENERGY MODULES;
- U.S. Patent Application Docket No. END9068USNP5/180680-5, titled ENERGY MODULE FOR DRIVING MULTIPLE ENERGY MODALITIES THROUGH A PORT;
- U.S. Patent Application Docket No. END9068USNP6/180680-6 titled SURGICAL INSTRUMENT UTILIZING DRIVE SIGNAL TO POWER SECONDARY FUNCTION;
- U.S. Patent Application Docket No. END9038USNP1/180529-1M, titled METHOD FOR CONTROLLING A MODULAR ENERGY SYSTEM USER INTERFACE;
- U.S. Patent Application Docket No. END9038USNP2/180529-2, titled PASSIVE HEADER MODULE FOR A MODULAR ENERGY SYSTEM;
- U.S. Patent Application Docket No. END9038USNP3/180529-3, titled CONSOLIDATED USER INTERFACE FOR MODULAR ENERGY SYSTEM;
- U.S. Patent Application Docket No. END9038USNP4/180529-4, titled AUDIO TONE CONSTRUCTION FOR AN ENERGY MODULE OF A MODULAR ENERGY SYSTEM;
- U.S. Patent Application Docket No. END9038USNP5/180529-5, titled ADAPTABLY CONNECTABLE AND REASSIGNABLE SYSTEM ACCESSORIES FOR MODULAR ENERGY SYSTEM;
- U.S. Patent Application Docket No. END9070USNP1/180682-1M, titled METHOD FOR COMMUNICATING BETWEEN MODULES AND DEVICES IN A MODULAR SURGICAL SYSTEM;
- U.S. Patent Application Docket No. END9070USNP2/180682-2, titled FLEXIBLE HAND-SWITCH CIRCUIT;
- U.S. Patent Application Docket No. END9070USNP3/180682-3, titled FIRST AND SECOND COMMUNICATION PROTOCOL ARRANGEMENT FOR DRIVING PRIMARY AND SECONDARY DEVICES THROUGH A SINGLE PORT;
- U.S. Patent Application Docket No. END9070USNP4/180682-4, titled FLEXIBLE NEUTRAL ELECTRODE;
- U.S. Patent Application Docket No. END9070USNP5/180682-5, titled SMART RETURN PAD SENSING THROUGH MODULATION OF NEAR FIELD COMMUNICATION AND CONTACT QUALITY MONITORING SIGNALS;
- U.S. Patent Application Docket No. END9070USNP6/180682-6, titled AUTOMATIC ULTRASONIC ENERGY ACTIVATION CIRCUIT DESIGN FOR MODULAR SURGICAL SYSTEMS;

- U.S. Patent Application Docket No. END9070USNP7/180682-7, titled COORDINATED ENERGY OUTPUTS OF SEPARATE BUT CONNECTED MODULES;
- U.S. Patent Application Docket No. END9070USNP8/180682-8, titled MANAGING SIMULTANEOUS MONOPOLAR OUTPUTS USING DUTY CYCLE AND SYNCHRONIZATION;
- U.S. Patent Application Docket No. END9070USNP9/180682-9, titled PORT PRESENCE DETECTION SYSTEM FOR MODULAR ENERGY SYSTEM;
- U.S. Patent Application Docket No. END9070USNP10/180682-10, titled INSTRUMENT TRACKING ARRANGEMENT BASED ON REAL TIME CLOCK INFORMATION;
- U.S. Patent Application Docket No. END9070USNP11/180682-11, titled REGIONAL LOCATION TRACKING OF COMPONENTS OF A MODULAR ENERGY SYSTEM;
- U.S. Design Patent Application Docket No. END9212USDP1/190370D, titled ENERGY MODULE;
- U.S. Design Patent Application Docket No. END9213USDP1/190371D, titled ENERGY MODULE MONOPOLAR PORT WITH FOURTH SOCKET AMONG THREE OTHER SOCKETS;
- U.S. Design Patent Application Docket No. END9214USDP1/190372D, titled BACKPLANE CONNECTOR FOR ENERGY MODULE; and
- U.S. Design Patent Application Docket No. END9215USDP1/190373D, titled ALERT SCREEN FOR ENERGY MODULE.

[0056] Before explaining various aspects of surgical devices and generators in detail, it should be noted that the illustrative examples are not limited in application or use to the details of construction and arrangement of parts illustrated in the accompanying drawings and description. The illustrative examples may be implemented or incorporated in other aspects, variations and modifications, and may be practiced or carried out in various ways. Further, unless otherwise indicated, the terms and expressions employed herein have been chosen for the purpose of describing the illustrative examples for the convenience of the reader and are not for the purpose of limitation thereof. Also, it will be appreciated that one or more of the following-described aspects, expressions of aspects, and/or examples, can be combined with any one or more of the other following-described aspects, expressions of aspects and/or examples.

[0057] Various aspects are directed to improved ultrasonic surgical devices, electrosurgical devices and generators for use therewith. Aspects of the ultrasonic surgical devices can be configured for transecting and/or coagulating tissue during surgical

procedures, for example. Aspects of the electrosurgical devices can be configured for transecting, coagulating, scaling, welding and/or desiccating tissue during surgical procedures, for example.

Surgical System Hardware

[0058] Referring to FIG. 1, a computer-implemented interactive surgical system 100 includes one or more surgical systems 102 and a cloud-based system (e.g., the cloud 104 that may include a remote server 113 coupled to a storage device 105). Each surgical system 102 includes at least one surgical hub 106 in communication with the cloud 104 that may include a remote server 113. In one example, as illustrated in FIG. 1, the surgical system 102 includes a visualization system 108, a robotic system 110, and a handheld intelligent surgical instrument 112, which are configured to communicate with one another and/or the hub 106. In some aspects, a surgical system 102 may include an M number of hubs 106, an N number of visualization systems 108, an O number of robotic systems 110, and a P number of handheld intelligent surgical instruments 112, where M, N, O, and P are integers greater than or equal to one.

[0059] FIG. 2 depicts an example of a surgical system 102 being used to perform a surgical procedure on a patient who is lying down on an operating table 114 in a surgical operating room 116. A robotic system 110 is used in the surgical procedure as a part of the surgical system 102. The robotic system 110 includes a surgeon's console 118, a patient side cart 120 (surgical robot), and a surgical robotic hub 122. The patient side cart 120 can manipulate at least one removably coupled surgical tool 117 through a minimally invasive incision in the body of the patient while the surgeon views the surgical site through the surgeon's console 118. An image of the surgical site can be obtained by a medical imaging device 124, which can be manipulated by the patient side cart 120 to orient the imaging device 124. The robotic hub 122 can be used to process the images of the surgical site for subsequent display to the surgeon through the surgeon's console 118.

[0060] Other types of robotic systems can be readily adapted for use with the surgical system 102. Various examples of robotic systems and surgical tools that are suitable for use with the present disclosure are described in U.S. Provisional Patent Application Serial No. 62/611,339, titled ROBOT ASSISTED SURGICAL PLATFORM, filed December 28, 2017, the disclosure of which is herein incorporated by reference in its entirety.

[0061] Various examples of cloud-based analytics that are performed by the cloud 104, and are suitable for use with the present disclosure, are described in U.S. Provisional Patent Application Serial No. 62/611,340, titled CLOUD-BASED MEDICAL ANALYTICS, filed

December 28, 2017, the disclosure of which is herein incorporated by reference in its entirety.

[0062] In various aspects, the imaging device 124 includes at least one image sensor and one or more optical components. Suitable image sensors include, but are not limited to, Charge-Coupled Device (CCD) sensors and Complementary Metal-Oxide Semiconductor (CMOS) sensors.

[0063] The optical components of the imaging device 124 may include one or more illumination sources and/or one or more lenses. The one or more illumination sources may be directed to illuminate portions of the surgical field. The one or more image sensors may receive light reflected or refracted from the surgical field, including light reflected or refracted from tissue and/or surgical instruments.

[0064] The one or more illumination sources may be configured to radiate electromagnetic energy in the visible spectrum as well as the invisible spectrum. The visible spectrum, sometimes referred to as the optical spectrum or luminous spectrum, is that portion of the electromagnetic spectrum that is visible to (i.e., can be detected by) the human eye and may be referred to as visible light or simply light. A typical human eye will respond to wavelengths in air that are from about 380 nm to about 750 nm.

[0065] The invisible spectrum (i.e., the non-luminous spectrum) is that portion of the electromagnetic spectrum that lies below and above the visible spectrum (i.e., wavelengths below about 380 nm and above about 750 nm). The invisible spectrum is not detectable by the human eye. Wavelengths greater than about 750 nm are longer than the red visible spectrum, and they become invisible infrared (IR), microwave, and radio electromagnetic radiation. Wavelengths less than about 380 nm are shorter than the violet spectrum, and they become invisible ultraviolet, x-ray, and gamma ray electromagnetic radiation.

[0066] In various aspects, the imaging device 124 is configured for use in a minimally invasive procedure. Examples of imaging devices suitable for use with the present disclosure include, but not limited to, an arthroscope, angioscope, bronchoscope, choledochoscope, colonoscope, cytoscope, duodenoscope, enteroscope, esophagogastro-duodenoscope (gastroscope), endoscope, laryngoscope, nasopharyngo-neproscope, sigmoidoscope, thoracoscope, and ureteroscope.

[0067] In one aspect, the imaging device employs multi-spectrum monitoring to discriminate topography and underlying structures. A multi-spectral image is one that captures image data within specific wavelength ranges across the electromagnetic spectrum. The wavelengths may be separated by filters or by the use of instruments that are sensitive to particular wavelengths, including light from frequencies beyond the visible light range, e.g., IR and ultraviolet. Spectral imaging can allow extraction of additional information the human eye fails to capture with its receptors for red, green, and blue. The use of multi-

spectral imaging is described in greater detail under the heading “Advanced Imaging Acquisition Module” in U.S. Provisional Patent Application Serial No. 62/611,341, titled INTERACTIVE SURGICAL PLATFORM, filed December 28, 2017, the disclosure of which is herein incorporated by reference in its entirety. Multi-spectrum monitoring can be a useful tool in relocating a surgical field after a surgical task is completed to perform one or more of the previously described tests on the treated tissue.

[0068] It is axiomatic that strict sterilization of the operating room and surgical equipment is required during any surgery. The strict hygiene and sterilization conditions required in a “surgical theater,” i.e., an operating or treatment room, necessitate the highest possible sterility of all medical devices and equipment. Part of that sterilization process is the need to sterilize anything that comes in contact with the patient or penetrates the sterile field, including the imaging device 124 and its attachments and components. It will be appreciated that the sterile field may be considered a specified area, such as within a tray or on a sterile towel, that is considered free of microorganisms, or the sterile field may be considered an area, immediately around a patient, who has been prepared for a surgical procedure. The sterile field may include the scrubbed team members, who are properly attired, and all furniture and fixtures in the area.

In various aspects, the visualization system 108 includes one or more imaging sensors, one or more image-processing units, one or more storage arrays, and one or more displays that are strategically arranged with respect to the sterile field, as illustrated in FIG. 2. In one aspect, the visualization system 108 includes an interface for HL7, PACS, and EMR. Various components of the visualization system 108 are described under the heading “Advanced Imaging Acquisition Module” in U.S. Provisional Patent Application Serial No. 62/611,341, titled INTERACTIVE SURGICAL PLATFORM, filed December 28, 2017, the disclosure of which is herein incorporated by reference in its entirety.

[0069] As illustrated in FIG. 2, a primary display 119 is positioned in the sterile field to be visible to an operator at the operating table 114. In addition, a visualization tower 111 is positioned outside the sterile field. The visualization tower 111 includes a first non-sterile display 107 and a second non-sterile display 109, which face away from each other. The visualization system 108, guided by the hub 106, is configured to utilize the displays 107, 109, and 119 to coordinate information flow to operators inside and outside the sterile field. For example, the hub 106 may cause the visualization system 108 to display a snapshot of a surgical site, as recorded by an imaging device 124, on a non-sterile display 107 or 109, while maintaining a live feed of the surgical site on the primary display 119. The snapshot on the non-sterile display 107 or 109 can permit a non-sterile operator to perform a diagnostic step relevant to the surgical procedure, for example.

[0070] In one aspect, the hub 106 is also configured to route a diagnostic input or feedback entered by a non-sterile operator at the visualization tower 111 to the primary display 119 within the sterile field, where it can be viewed by a sterile operator at the operating table. In one example, the input can be in the form of a modification to the snapshot displayed on the non-sterile display 107 or 109, which can be routed to the primary display 119 by the hub 106.

[0071] Referring to FIG. 2, a surgical instrument 112 is being used in the surgical procedure as part of the surgical system 102. The hub 106 is also configured to coordinate information flow to a display of the surgical instrument 112. For example, in U.S. Provisional Patent Application Serial No. 62/611,341, titled INTERACTIVE SURGICAL PLATFORM, filed December 28, 2017, the disclosure of which is herein incorporated by reference in its entirety. A diagnostic input or feedback entered by a non-sterile operator at the visualization tower 111 can be routed by the hub 106 to the surgical instrument display 115 within the sterile field, where it can be viewed by the operator of the surgical instrument 112. Example surgical instruments that are suitable for use with the surgical system 102 are described under the heading SURGICAL INSTRUMENT HARDWARE and in U.S. Provisional Patent Application Serial No. 62/611,341, titled INTERACTIVE SURGICAL PLATFORM, filed December 28, 2017, the disclosure of which is herein incorporated by reference in its entirety, for example.

[0072] Referring now to FIG. 3, a hub 106 is depicted in communication with a visualization system 108, a robotic system 110, and a handheld intelligent surgical instrument 112. The hub 106 includes a hub display 135, an imaging module 138, a generator module 140, a communication module 130, a processor module 132, and a storage array 134. In certain aspects, as illustrated in FIG. 3, the hub 106 further includes a smoke evacuation module 126 and/or a suction/irrigation module 128.

[0073] During a surgical procedure, energy application to tissue, for sealing and/or cutting, is generally associated with smoke evacuation, suction of excess fluid, and/or irrigation of the tissue. Fluid, power, and/or data lines from different sources are often entangled during the surgical procedure. Valuable time can be lost addressing this issue during a surgical procedure. Detangling the lines may necessitate disconnecting the lines from their respective modules, which may require resetting the modules. The hub modular enclosure 136 offers a unified environment for managing the power, data, and fluid lines, which reduces the frequency of entanglement between such lines.

[0074] Aspects of the present disclosure present a surgical hub for use in a surgical procedure that involves energy application to tissue at a surgical site. The surgical hub includes a hub enclosure and a combo generator module slidably receivable in a docking station of the hub enclosure. The docking station includes data and power contacts. The

combo generator module includes two or more of an ultrasonic energy generator component, a bipolar RF energy generator component, and a monopolar RF energy generator component that are housed in a single unit. In one aspect, the combo generator module also includes a smoke evacuation component, at least one energy delivery cable for connecting the combo generator module to a surgical instrument, at least one smoke evacuation component configured to evacuate smoke, fluid, and/or particulates generated by the application of therapeutic energy to the tissue, and a fluid line extending from the remote surgical site to the smoke evacuation component.

[0075] In one aspect, the fluid line is a first fluid line and a second fluid line extends from the remote surgical site to a suction and irrigation module slidably received in the hub enclosure. In one aspect, the hub enclosure comprises a fluid interface.

[0076] Certain surgical procedures may require the application of more than one energy type to the tissue. One energy type may be more beneficial for cutting the tissue, while another different energy type may be more beneficial for sealing the tissue. For example, a bipolar generator can be used to seal the tissue while an ultrasonic generator can be used to cut the sealed tissue. Aspects of the present disclosure present a solution where a hub modular enclosure 136 is configured to accommodate different generators, and facilitate an interactive communication therebetween. One of the advantages of the hub modular enclosure 136 is enabling the quick removal and/or replacement of various modules.

[0077] Aspects of the present disclosure present a modular surgical enclosure for use in a surgical procedure that involves energy application to tissue. The modular surgical enclosure includes a first energy-generator module, configured to generate a first energy for application to the tissue, and a first docking station comprising a first docking port that includes first data and power contacts, wherein the first energy-generator module is slidably movable into an electrical engagement with the power and data contacts and wherein the first energy-generator module is slidably movable out of the electrical engagement with the first power and data contacts,

[0078] Further to the above, the modular surgical enclosure also includes a second energy-generator module configured to generate a second energy, different than the first energy, for application to the tissue, and a second docking station comprising a second docking port that includes second data and power contacts, wherein the second energy-generator module is slidably movable into an electrical engagement with the power and data contacts, and wherein the second energy-generator module is slidably movable out of the electrical engagement with the second power and data contacts.

[0079] In addition, the modular surgical enclosure also includes a communication bus between the first docking port and the second docking port, configured to facilitate

communication between the first energy-generator module and the second energy-generator module.

[0080] Referring to FIGS. 3–7, aspects of the present disclosure are presented for a hub modular enclosure 136 that allows the modular integration of a generator module 140, a smoke evacuation module 126, and a suction/irrigation module 128. The hub modular enclosure 136 further facilitates interactive communication between the modules 140, 126, 128. As illustrated in FIG. 5, the generator module 140 can be a generator module with integrated monopolar, bipolar, and ultrasonic components supported in a single housing unit 139 slidably insertable into the hub modular enclosure 136. As illustrated in FIG. 5, the generator module 140 can be configured to connect to a monopolar device 146, a bipolar device 147, and an ultrasonic device 148. Alternatively, the generator module 140 may comprise a series of monopolar, bipolar, and/or ultrasonic generator modules that interact through the hub modular enclosure 136. The hub modular enclosure 136 can be configured to facilitate the insertion of multiple generators and interactive communication between the generators docked into the hub modular enclosure 136 so that the generators would act as a single generator.

[0081] In one aspect, the hub modular enclosure 136 comprises a modular power and communication backplane 149 with external and wireless communication headers to enable the removable attachment of the modules 140, 126, 128 and interactive communication therebetween.

[0082] In one aspect, the hub modular enclosure 136 includes docking stations, or drawers, 151, herein also referred to as drawers, which are configured to slidably receive the modules 140, 126, 128. FIG. 4 illustrates a partial perspective view of a surgical hub enclosure 136, and a combo generator module 145 slidably receivable in a docking station 151 of the surgical hub enclosure 136. A docking port 152 with power and data contacts on a rear side of the combo generator module 145 is configured to engage a corresponding docking port 150 with power and data contacts of a corresponding docking station 151 of the hub modular enclosure 136 as the combo generator module 145 is slid into position within the corresponding docking station 151 of the hub module enclosure 136. In one aspect, the combo generator module 145 includes a bipolar, ultrasonic, and monopolar module and a smoke evacuation module integrated together into a single housing unit 139, as illustrated in FIG. 5.

[0083] In various aspects, the smoke evacuation module 126 includes a fluid line 154 that conveys captured/collected smoke and/or fluid away from a surgical site and to, for example, the smoke evacuation module 126. Vacuum suction originating from the smoke evacuation module 126 can draw the smoke into an opening of a utility conduit at the surgical site. The utility conduit, coupled to the fluid line, can be in the form of a flexible tube terminating at the

smoke evacuation module 126. The utility conduit and the fluid line define a fluid path extending toward the smoke evacuation module 126 that is received in the hub enclosure 136.

[0084] In various aspects, the suction/irrigation module 128 is coupled to a surgical tool comprising an aspiration fluid line and a suction fluid line. In one example, the aspiration and suction fluid lines are in the form of flexible tubes extending from the surgical site toward the suction/irrigation module 128. One or more drive systems can be configured to cause irrigation and aspiration of fluids to and from the surgical site.

[0085] In one aspect, the surgical tool includes a shaft having an end effector at a distal end thereof and at least one energy treatment associated with the end effector, an aspiration tube, and an irrigation tube. The aspiration tube can have an inlet port at a distal end thereof and the aspiration tube extends through the shaft. Similarly, an irrigation tube can extend through the shaft and can have an inlet port in proximity to the energy deliver implement. The energy deliver implement is configured to deliver ultrasonic and/or RF energy to the surgical site and is coupled to the generator module 140 by a cable extending initially through the shaft.

[0086] The irrigation tube can be in fluid communication with a fluid source, and the aspiration tube can be in fluid communication with a vacuum source. The fluid source and/or the vacuum source can be housed in the suction/irrigation module 128. In one example, the fluid source and/or the vacuum source can be housed in the hub enclosure 136 separately from the suction/irrigation module 128. In such example, a fluid interface can be configured to connect the suction/irrigation module 128 to the fluid source and/or the vacuum source.

[0087] In one aspect, the modules 140, 126, 128 and/or their corresponding docking stations on the hub modular enclosure 136 may include alignment features that are configured to align the docking ports of the modules into engagement with their counterparts in the docking stations of the hub modular enclosure 136. For example, as illustrated in FIG. 4, the combo generator module 145 includes side brackets 155 that are configured to slidably engage with corresponding brackets 156 of the corresponding docking station 151 of the hub modular enclosure 136. The brackets cooperate to guide the docking port contacts of the combo generator module 145 into an electrical engagement with the docking port contacts of the hub modular enclosure 136.

[0088] In some aspects, the drawers 151 of the hub modular enclosure 136 are the same, or substantially the same size, and the modules are adjusted in size to be received in the drawers 151. For example, the side brackets 155 and/or 156 can be larger or smaller depending on the size of the module. In other aspects, the drawers 151 are different in size and are each designed to accommodate a particular module.

[0089] Furthermore, the contacts of a particular module can be keyed for engagement with the contacts of a particular drawer to avoid inserting a module into a drawer with mismatching contacts.

[0090] As illustrated in FIG. 4, the docking port 150 of one drawer 151 can be coupled to the docking port 150 of another drawer 151 through a communications link 157 to facilitate an interactive communication between the modules housed in the hub modular enclosure 136. The docking ports 150 of the hub modular enclosure 136 may alternatively, or additionally, facilitate a wireless interactive communication between the modules housed in the hub modular enclosure 136. Any suitable wireless communication can be employed, such as for example Air Titan-Bluetooth.

[0091] FIG. 6 illustrates individual power bus attachments for a plurality of lateral docking ports of a lateral modular housing 160 configured to receive a plurality of modules of a surgical hub 206. The lateral modular housing 160 is configured to laterally receive and interconnect the modules 161. The modules 161 are slidably inserted into docking stations 162 of lateral modular housing 160, which includes a backplane for interconnecting the modules 161. As illustrated in FIG. 6, the modules 161 are arranged laterally in the lateral modular housing 160. Alternatively, the modules 161 may be arranged vertically in a lateral modular housing.

[0092] FIG. 7 illustrates a vertical modular housing 164 configured to receive a plurality of modules 165 of the surgical hub 106. The modules 165 are slidably inserted into docking stations, or drawers, 167 of vertical modular housing 164, which includes a backplane for interconnecting the modules 165. Although the drawers 167 of the vertical modular housing 164 are arranged vertically, in certain instances, a vertical modular housing 164 may include drawers that are arranged laterally. Furthermore, the modules 165 may interact with one another through the docking ports of the vertical modular housing 164. In the example of FIG. 7, a display 177 is provided for displaying data relevant to the operation of the modules 165. In addition, the vertical modular housing 164 includes a master module 178 housing a plurality of sub-modules that are slidably received in the master module 178.

[0093] In various aspects, the imaging module 138 comprises an integrated video processor and a modular light source and is adapted for use with various imaging devices. In one aspect, the imaging device is comprised of a modular housing that can be assembled with a light source module and a camera module. The housing can be a disposable housing. In at least one example, the disposable housing is removably coupled to a reusable controller, a light source module, and a camera module. The light source module and/or the camera module can be selectively chosen depending on the type of surgical procedure. In one aspect, the camera module comprises a CCD sensor. In another aspect, the camera module comprises a CMOS sensor. In another aspect, the camera module is configured for

scanned beam imaging. Likewise, the light source module can be configured to deliver a white light or a different light, depending on the surgical procedure.

[0094] During a surgical procedure, removing a surgical device from the surgical field and replacing it with another surgical device that includes a different camera or a different light source can be inefficient. Temporarily losing sight of the surgical field may lead to undesirable consequences. The module imaging device of the present disclosure is configured to permit the replacement of a light source module or a camera module midstream during a surgical procedure, without having to remove the imaging device from the surgical field.

[0095] In one aspect, the imaging device comprises a tubular housing that includes a plurality of channels. A first channel is configured to slidably receive the camera module, which can be configured for a snap-fit engagement with the first channel. A second channel is configured to slidably receive the light source module, which can be configured for a snap-fit engagement with the second channel. In another example, the camera module and/or the light source module can be rotated into a final position within their respective channels. A threaded engagement can be employed in lieu of the snap-fit engagement.

[0096] In various examples, multiple imaging devices are placed at different positions in the surgical field to provide multiple views. The imaging module 138 can be configured to switch between the imaging devices to provide an optimal view. In various aspects, the imaging module 138 can be configured to integrate the images from the different imaging device.

[0097] Various image processors and imaging devices suitable for use with the present disclosure are described in U.S. Patent No. 7,995,045, titled COMBINED SBI AND CONVENTIONAL IMAGE PROCESSOR, which issued on August 9, 2011, which is herein incorporated by reference in its entirety. In addition, U.S. Patent No. 7,982,776, titled SBI MOTION ARTIFACT REMOVAL APPARATUS AND METHOD, which issued on July 19, 2011, which is herein incorporated by reference in its entirety, describes various systems for removing motion artifacts from image data. Such systems can be integrated with the imaging module 138. Furthermore, U.S. Patent Application Publication No. 2011/0306840, titled CONTROLLABLE MAGNETIC SOURCE TO FIXTURE INTRACORPOREAL APPARATUS, which published on December 15, 2011, and U.S. Patent Application Publication No. 2014/0243597, titled SYSTEM FOR PERFORMING A MINIMALLY INVASIVE SURGICAL PROCEDURE, which published on August 28, 2014, each of which is herein incorporated by reference in its entirety.

[0098] FIG. 8 illustrates a surgical data network 201 comprising a modular communication hub 203 configured to connect modular devices located in one or more operating theaters of a healthcare facility, or any room in a healthcare facility specially equipped for surgical

operations, to a cloud-based system (e.g., the cloud 204 that may include a remote server 213 coupled to a storage device 205). In one aspect, the modular communication hub 203 comprises a network hub 207 and/or a network switch 209 in communication with a network router. The modular communication hub 203 also can be coupled to a local computer system 210 to provide local computer processing and data manipulation. The surgical data network 201 may be configured as passive, intelligent, or switching. A passive surgical data network serves as a conduit for the data, enabling it to go from one device (or segment) to another and to the cloud computing resources. An intelligent surgical data network includes additional features to enable the traffic passing through the surgical data network to be monitored and to configure each port in the network hub 207 or network switch 209. An intelligent surgical data network may be referred to as a manageable hub or switch. A switching hub reads the destination address of each packet and then forwards the packet to the correct port.

[0099] Modular devices 1a-1n located in the operating theater may be coupled to the modular communication hub 203. The network hub 207 and/or the network switch 209 may be coupled to a network router 211 to connect the devices 1a-1n to the cloud 204 or the local computer system 210. Data associated with the devices 1a-1n may be transferred to cloud-based computers via the router for remote data processing and manipulation. Data associated with the devices 1a-1n may also be transferred to the local computer system 210 for local data processing and manipulation. Modular devices 2a-2m located in the same operating theater also may be coupled to a network switch 209. The network switch 209 may be coupled to the network hub 207 and/or the network router 211 to connect to the devices 2a-2m to the cloud 204. Data associated with the devices 2a-2m may be transferred to the cloud 204 via the network router 211 for data processing and manipulation. Data associated with the devices 2a-2m may also be transferred to the local computer system 210 for local data processing and manipulation.

[0100] It will be appreciated that the surgical data network 201 may be expanded by interconnecting multiple network hubs 207 and/or multiple network switches 209 with multiple network routers 211. The modular communication hub 203 may be contained in a modular control tower configured to receive multiple devices 1a-1n/2a-2m. The local computer system 210 also may be contained in a modular control tower. The modular communication hub 203 is connected to a display 212 to display images obtained by some of the devices 1a-1n/2a-2m, for example during surgical procedures. In various aspects, the devices 1a-1n/2a-2m may include, for example, various modules such as an imaging module 138 coupled to an endoscope, a generator module 140 coupled to an energy-based surgical device, a smoke evacuation module 126, a suction/irrigation module 128, a communication module 130, a processor module 132, a storage array 134, a surgical device coupled to a

display, and/or a non-contact sensor module, among other modular devices that may be connected to the modular communication hub 203 of the surgical data network 201.

[0101] In one aspect, the surgical data network 201 may comprise a combination of network hub(s), network switch(es), and network router(s) connecting the devices 1a-1n/2a-2m to the cloud. Any one of or all of the devices 1a-1n/2a-2m coupled to the network hub or network switch may collect data in real time and transfer the data to cloud computers for data processing and manipulation. It will be appreciated that cloud computing relies on sharing computing resources rather than having local servers or personal devices to handle software applications. The word “cloud” may be used as a metaphor for “the Internet,” although the term is not limited as such. Accordingly, the term “cloud computing” may be used herein to refer to “a type of Internet-based computing,” where different services—such as servers, storage, and applications—are delivered to the modular communication hub 203 and/or computer system 210 located in the surgical theater (e.g., a fixed, mobile, temporary, or field operating room or space) and to devices connected to the modular communication hub 203 and/or computer system 210 through the Internet. The cloud infrastructure may be maintained by a cloud service provider. In this context, the cloud service provider may be the entity that coordinates the usage and control of the devices 1a-1n/2a-2m located in one or more operating theaters. The cloud computing services can perform a large number of calculations based on the data gathered by smart surgical instruments, robots, and other computerized devices located in the operating theater. The hub hardware enables multiple devices or connections to be connected to a computer that communicates with the cloud computing resources and storage.

[0102] Applying cloud computer data processing techniques on the data collected by the devices 1a-1n/2a-2m, the surgical data network provides improved surgical outcomes, reduced costs, and improved patient satisfaction. At least some of the devices 1a-1n/2a-2m may be employed to view tissue states to assess leaks or perfusion of sealed tissue after a tissue sealing and cutting procedure. At least some of the devices 1a-1n/2a-2m may be employed to identify pathology, such as the effects of diseases, using the cloud-based computing to examine data including images of samples of body tissue for diagnostic purposes. This includes localization and margin confirmation of tissue and phenotypes. At least some of the devices 1a-1n/2a-2m may be employed to identify anatomical structures of the body using a variety of sensors integrated with imaging devices and techniques such as overlaying images captured by multiple imaging devices. The data gathered by the devices 1a-1n/2a-2m, including image data, may be transferred to the cloud 204 or the local computer system 210 or both for data processing and manipulation including image processing and manipulation. The data may be analyzed to improve surgical procedure outcomes by determining if further treatment, such as the application of endoscopic

intervention, emerging technologies, a targeted radiation, targeted intervention, and precise robotics to tissue-specific sites and conditions, may be pursued. Such data analysis may further employ outcome analytics processing, and using standardized approaches may provide beneficial feedback to either confirm surgical treatments and the behavior of the surgeon or suggest modifications to surgical treatments and the behavior of the surgeon.

[0103] In one implementation, the operating theater devices 1a-1n may be connected to the modular communication hub 203 over a wired channel or a wireless channel depending on the configuration of the devices 1a-1n to a network hub. The network hub 207 may be implemented, in one aspect, as a local network broadcast device that works on the physical layer of the Open System Interconnection (OSI) model. The network hub provides connectivity to the devices 1a-1n located in the same operating theater network. The network hub 207 collects data in the form of packets and sends them to the router in half duplex mode. The network hub 207 does not store any media access control/Internet Protocol (MAC/IP) to transfer the device data. Only one of the devices 1a-1n can send data at a time through the network hub 207. The network hub 207 has no routing tables or intelligence regarding where to send information and broadcasts all network data across each connection and to a remote server 213 (FIG. 9) over the cloud 204. The network hub 207 can detect basic network errors such as collisions, but having all information broadcast to multiple ports can be a security risk and cause bottlenecks.

[0104] In another implementation, the operating theater devices 2a-2m may be connected to a network switch 209 over a wired channel or a wireless channel. The network switch 209 works in the data link layer of the OSI model. The network switch 209 is a multicast device for connecting the devices 2a-2m located in the same operating theater to the network. The network switch 209 sends data in the form of frames to the network router 211 and works in full duplex mode. Multiple devices 2a-2m can send data at the same time through the network switch 209. The network switch 209 stores and uses MAC addresses of the devices 2a-2m to transfer data.

[0105] The network hub 207 and/or the network switch 209 are coupled to the network router 211 for connection to the cloud 204. The network router 211 works in the network layer of the OSI model. The network router 211 creates a route for transmitting data packets received from the network hub 207 and/or network switch 211 to cloud-based computer resources for further processing and manipulation of the data collected by any one of or all the devices 1a-1n/2a-2m. The network router 211 may be employed to connect two or more different networks located in different locations, such as, for example, different operating theaters of the same healthcare facility or different networks located in different operating theaters of different healthcare facilities. The network router 211 sends data in the form of

packets to the cloud 204 and works in full duplex mode. Multiple devices can send data at the same time. The network router 211 uses IP addresses to transfer data.

[0106] In one example, the network hub 207 may be implemented as a USB hub, which allows multiple USB devices to be connected to a host computer. The USB hub may expand a single USB port into several tiers so that there are more ports available to connect devices to the host system computer. The network hub 207 may include wired or wireless capabilities to receive information over a wired channel or a wireless channel. In one aspect, a wireless USB short-range, high-bandwidth wireless radio communication protocol may be employed for communication between the devices 1a-1n and devices 2a-2m located in the operating theater.

[0107] In other examples, the operating theater devices 1a-1n/2a-2m may communicate to the modular communication hub 203 via Bluetooth wireless technology standard for exchanging data over short distances (using short-wavelength UHF radio waves in the ISM band from 2.4 to 2.485 GHz) from fixed and mobile devices and building personal area networks (PANs). In other aspects, the operating theater devices 1a-1n/2a-2m may communicate to the modular communication hub 203 via a number of wireless or wired communication standards or protocols, including but not limited to Wi-Fi (IEEE 802.11 family), WiMAX (IEEE 802.16 family), IEEE 802.20, long-term evolution (LTE), and Ev-DO, HSPA+, HSDPA+, HSUPA+, EDGE, GSM, GPRS, CDMA, TDMA, DECT, and Ethernet derivatives thereof, as well as any other wireless and wired protocols that are designated as 3G, 4G, 5G, and beyond. The computing module may include a plurality of communication modules. For instance, a first communication module may be dedicated to shorter-range wireless communications such as Wi-Fi and Bluetooth, and a second communication module may be dedicated to longer-range wireless communications such as GPS, EDGE, GPRS, CDMA, WiMAX, LTE, Ev-DO, and others.

[0108] The modular communication hub 203 may serve as a central connection for one or all of the operating theater devices 1a-1n/2a-2m and handles a data type known as frames. Frames carry the data generated by the devices 1a-1n/2a-2m. When a frame is received by the modular communication hub 203, it is amplified and transmitted to the network router 211, which transfers the data to the cloud computing resources by using a number of wireless or wired communication standards or protocols, as described herein.

[0109] The modular communication hub 203 can be used as a standalone device or be connected to compatible network hubs and network switches to form a larger network. The modular communication hub 203 is generally easy to install, configure, and maintain, making it a good option for networking the operating theater devices 1a-1n/2a-2m.

[0110] FIG. 9 illustrates a computer-implemented interactive surgical system 200. The computer-implemented interactive surgical system 200 is similar in many respects to the

computer-implemented interactive surgical system 100. For example, the computer-implemented interactive surgical system 200 includes one or more surgical systems 202, which are similar in many respects to the surgical systems 102. Each surgical system 202 includes at least one surgical hub 206 in communication with a cloud 204 that may include a remote server 213. In one aspect, the computer-implemented interactive surgical system 200 comprises a modular control tower 236 connected to multiple operating theater devices such as, for example, intelligent surgical instruments, robots, and other computerized devices located in the operating theater. As shown in FIG. 10, the modular control tower 236 comprises a modular communication hub 203 coupled to a computer system 210. As illustrated in the example of FIG. 9, the modular control tower 236 is coupled to an imaging module 238 that is coupled to an endoscope 239, a generator module 240 that is coupled to an energy device 241, a smoke evacuator module 226, a suction/irrigation module 228, a communication module 230, a processor module 232, a storage array 234, a smart device/instrument 235 optionally coupled to a display 237, and a non-contact sensor module 242. The operating theater devices are coupled to cloud computing resources and data storage via the modular control tower 236. A robot hub 222 also may be connected to the modular control tower 236 and to the cloud computing resources. The devices/instruments 235, visualization systems 208, among others, may be coupled to the modular control tower 236 via wired or wireless communication standards or protocols, as described herein. The modular control tower 236 may be coupled to a hub display 215 (e.g., monitor, screen) to display and overlay images received from the imaging module, device/instrument display, and/or other visualization systems 208. The hub display also may display data received from devices connected to the modular control tower in conjunction with images and overlaid images.

[0111] FIG. 10 illustrates a surgical hub 206 comprising a plurality of modules coupled to the modular control tower 236. The modular control tower 236 comprises a modular communication hub 203, e.g., a network connectivity device, and a computer system 210 to provide local processing, visualization, and imaging, for example. As shown in FIG. 10, the modular communication hub 203 may be connected in a tiered configuration to expand the number of modules (e.g., devices) that may be connected to the modular communication hub 203 and transfer data associated with the modules to the computer system 210, cloud computing resources, or both. As shown in FIG. 10, each of the network hubs/switches in the modular communication hub 203 includes three downstream ports and one upstream port. The upstream network hub/switch is connected to a processor to provide a communication connection to the cloud computing resources and a local display 217. Communication to the cloud 204 may be made either through a wired or a wireless communication channel.

[0112] The surgical hub 206 employs a non-contact sensor module 242 to measure the dimensions of the operating theater and generate a map of the surgical theater using either ultrasonic or laser-type non-contact measurement devices. An ultrasound-based non-contact sensor module scans the operating theater by transmitting a burst of ultrasound and receiving the echo when it bounces off the perimeter walls of an operating theater as described under the heading “Surgical Hub Spatial Awareness Within an Operating Room” in U.S. Provisional Patent Application Serial No. 62/611,341, titled INTERACTIVE SURGICAL PLATFORM, filed December 28, 2017, which is herein incorporated by reference in its entirety, in which the sensor module is configured to determine the size of the operating theater and to adjust Bluetooth-pairing distance limits. A laser-based non-contact sensor module scans the operating theater by transmitting laser light pulses, receiving laser light pulses that bounce off the perimeter walls of the operating theater, and comparing the phase of the transmitted pulse to the received pulse to determine the size of the operating theater and to adjust Bluetooth pairing distance limits, for example.

[0113] The computer system 210 comprises a processor 244 and a network interface 245. The processor 244 is coupled to a communication module 247, storage 248, memory 249, non-volatile memory 250, and input/output interface 251 via a system bus. The system bus can be any of several types of bus structure(s) including the memory bus or memory controller, a peripheral bus or external bus, and/or a local bus using any variety of available bus architectures including, but not limited to, 9-bit bus, Industrial Standard Architecture (ISA), Micro-Charmel Architecture (MSA), Extended ISA (EISA), Intelligent Drive Electronics (IDE), VESA Local Bus (VLB), Peripheral Component Interconnect (PCI), USB, Advanced Graphics Port (AGP), Personal Computer Memory Card International Association bus (PCMCIA), Small Computer Systems Interface (SCSI), or any other proprietary bus.

[0114] The processor 244 may be any single-core or multicore processor such as those known under the trade name ARM Cortex by Texas Instruments. In one aspect, the processor may be an LM4F230H5QR ARM Cortex-M4F Processor Core, available from Texas Instruments, for example, comprising an on-chip memory of 256 KB single-cycle flash memory, or other non-volatile memory, up to 40 MHz, a prefetch buffer to improve performance above 40 MHz, a 32 KB single-cycle serial random access memory (SRAM), an internal read-only memory (ROM) loaded with StellarisWare® software, a 2 KB electrically erasable programmable read-only memory (EEPROM), and/or one or more pulse width modulation (PWM) modules, one or more quadrature encoder inputs (QEI) analogs, one or more 12-bit analog-to-digital converters (ADCs) with 12 analog input channels, details of which are available for the product datasheet.

[0115] In one aspect, the processor 244 may comprise a safety controller comprising two controller-based families such as TMS570 and RM4x, known under the trade name Hercules

ARM Cortex R4, also by Texas Instruments. The safety controller may be configured specifically for IEC 61508 and ISO 26262 safety critical applications, among others, to provide advanced integrated safety features while delivering scalable performance, connectivity, and memory options.

[0116] The system memory includes volatile memory and non-volatile memory. The basic input/output system (BIOS), containing the basic routines to transfer information between elements within the computer system, such as during start-up, is stored in non-volatile memory. For example, the non-volatile memory can include ROM, programmable ROM (PROM), electrically programmable ROM (EPROM), EEPROM, or flash memory. Volatile memory includes random-access memory (RAM), which acts as external cache memory. Moreover, RAM is available in many forms such as SRAM, dynamic RAM (DRAM), synchronous DRAM (SDRAM), double data rate SDRAM (DDR SDRAM), enhanced SDRAM (ESDRAM), Synchlink DRAM (SLDRAM), and direct Rambus RAM (DRRAM).

[0117] The computer system 210 also includes removable/non-removable, volatile/non-volatile computer storage media, such as for example disk storage. The disk storage includes, but is not limited to, devices like a magnetic disk drive, floppy disk drive, tape drive, Jaz drive, Zip drive, LS-60 drive, flash memory card, or memory stick. In addition, the disk storage can include storage media separately or in combination with other storage media including, but not limited to, an optical disc drive such as a compact disc ROM device (CD-ROM), compact disc recordable drive (CD-R Drive), compact disc rewritable drive (CD-RW Drive), or a digital versatile disc ROM drive (DVD-ROM). To facilitate the connection of the disk storage devices to the system bus, a removable or non-removable interface may be employed.

[0118] It is to be appreciated that the computer system 210 includes software that acts as an intermediary between users and the basic computer resources described in a suitable operating environment. Such software includes an operating system. The operating system, which can be stored on the disk storage, acts to control and allocate resources of the computer system. System applications take advantage of the management of resources by the operating system through program modules and program data stored either in the system memory or on the disk storage. It is to be appreciated that various components described herein can be implemented with various operating systems or combinations of operating systems.

[0119] A user enters commands or information into the computer system 210 through input device(s) coupled to the I/O interface 251. The input devices include, but are not limited to, a pointing device such as a mouse, trackball, stylus, touch pad, keyboard, microphone, joystick, game pad, satellite dish, scanner, TV tuner card, digital camera, digital video camera, web camera, and the like. These and other input devices connect to the processor

through the system bus via interface port(s). The interface port(s) include, for example, a serial port, a parallel port, a game port, and a USB. The output device(s) use some of the same types of ports as input device(s). Thus, for example, a USB port may be used to provide input to the computer system and to output information from the computer system to an output device. An output adapter is provided to illustrate that there are some output devices like monitors, displays, speakers, and printers, among other output devices that require special adapters. The output adapters include, by way of illustration and not limitation, video and sound cards that provide a means of connection between the output device and the system bus. It should be noted that other devices and/or systems of devices, such as remote computer(s), provide both input and output capabilities.

[0120] The computer system 210 can operate in a networked environment using logical connections to one or more remote computers, such as cloud computer(s), or local computers. The remote cloud computer(s) can be a personal computer, server, router, network PC, workstation, microprocessor-based appliance, peer device, or other common network node, and the like, and typically includes many or all of the elements described relative to the computer system. For purposes of brevity, only a memory storage device is illustrated with the remote computer(s). The remote computer(s) is logically connected to the computer system through a network interface and then physically connected via a communication connection. The network interface encompasses communication networks such as local area networks (LANs) and wide area networks (WANs). LAN technologies include Fiber Distributed Data Interface (FDDI), Copper Distributed Data Interface (CDDI), Ethernet/IEEE 802.3, Token Ring/IEEE 802.5 and the like. WAN technologies include, but are not limited to, point-to-point links, circuit-switching networks like Integrated Services Digital Networks (ISDN) and variations thereon, packet-switching networks, and Digital Subscriber Lines (DSL).

[0121] In various aspects, the computer system 210 of FIG. 10, the imaging module 238 and/or visualization system 208, and/or the processor module 232 of FIGS. 9–10, may comprise an image processor, image-processing engine, media processor, or any specialized digital signal processor (DSP) used for the processing of digital images. The image processor may employ parallel computing with single instruction, multiple data (SIMD) or multiple instruction, multiple data (MIMD) technologies to increase speed and efficiency. The digital image-processing engine can perform a range of tasks. The image processor may be a system on a chip with multicore processor architecture.

[0122] The communication connection(s) refers to the hardware/software employed to connect the network interface to the bus. While the communication connection is shown for illustrative clarity inside the computer system, it can also be external to the computer system 210. The hardware/software necessary for connection to the network interface includes, for

illustrative purposes only, internal and external technologies such as modems, including regular telephone-grade modems, cable modems, and DSL modems, ISDN adapters, and Ethernet cards.

[0123] FIG. 11 illustrates a functional block diagram of one aspect of a USB network hub 300 device, in accordance with at least one aspect of the present disclosure. In the illustrated aspect, the USB network hub device 300 employs a TUSB2036 integrated circuit hub by Texas Instruments. The USB network hub 300 is a CMOS device that provides an upstream USB transceiver port 302 and up to three downstream USB transceiver ports 304, 306, 308 in compliance with the USB 2.0 specification. The upstream USB transceiver port 302 is a differential root data port comprising a differential data minus (DM0) input paired with a differential data plus (DP0) input. The three downstream USB transceiver ports 304, 306, 308 are differential data ports where each port includes differential data plus (DP1-DP3) outputs paired with differential data minus (DM1-DM3) outputs.

[0124] The USB network hub 300 device is implemented with a digital state machine instead of a microcontroller, and no firmware programming is required. Fully compliant USB transceivers are integrated into the circuit for the upstream USB transceiver port 302 and all downstream USB transceiver ports 304, 306, 308. The downstream USB transceiver ports 304, 306, 308 support both full-speed and low-speed devices by automatically setting the slew rate according to the speed of the device attached to the ports. The USB network hub 300 device may be configured either in bus-powered or self-powered mode and includes a hub power logic 312 to manage power.

[0125] The USB network hub 300 device includes a serial interface engine 310 (SIE). The SIE 310 is the front end of the USB network hub 300 hardware and handles most of the protocol described in chapter 8 of the USB specification. The SIE 310 typically comprehends signaling up to the transaction level. The functions that it handles could include: packet recognition, transaction sequencing, SOP, EOP, RESET, and RESUME signal detection/generation, clock/data separation, non-return-to-zero invert (NRZI) data encoding/decoding and bit-stuffing, CRC generation and checking (token and data), packet ID (PID) generation and checking/decoding, and/or serial-parallel/parallel-serial conversion. The 310 receives a clock input 314 and is coupled to a suspend/resume logic and frame timer 316 circuit and a hub repeater circuit 318 to control communication between the upstream USB transceiver port 302 and the downstream USB transceiver ports 304, 306, 308 through port logic circuits 320, 322, 324. The SIE 310 is coupled to a command decoder 326 via interface logic to control commands from a serial EEPROM via a serial EEPROM interface 330.

[0126] In various aspects, the USB network hub 300 can connect 127 functions configured in up to six logical layers (tiers) to a single computer. Further, the USB network hub 300 can

connect to all peripherals using a standardized four-wire cable that provides both communication and power distribution. The power configurations are bus-powered and self-powered modes. The USB network hub 300 may be configured to support four modes of power management: a bus-powered hub, with either individual-port power management or ganged-port power management, and the self-powered hub, with either individual-port power management or ganged-port power management. In one aspect, using a USB cable, the USB network hub 300, the upstream USB transceiver port 302 is plugged into a USB host controller, and the downstream USB transceiver ports 304, 306, 308 are exposed for connecting USB compatible devices, and so forth.

Surgical Instrument Hardware

[0127] FIG. 12 illustrates a logic diagram of a control system 470 of a surgical instrument or tool in accordance with one or more aspects of the present disclosure. The system 470 comprises a control circuit. The control circuit includes a microcontroller 461 comprising a processor 462 and a memory 468. One or more of sensors 472, 474, 476, for example, provide real-time feedback to the processor 462. A motor 482, driven by a motor driver 492, operably couples a longitudinally movable displacement member to drive a clamp arm closure member. A tracking system 480 is configured to determine the position of the longitudinally movable displacement member. The position information is provided to the processor 462, which can be programmed or configured to determine the position of the longitudinally movable drive member as well as the position of the closure member. Additional motors may be provided at the tool driver interface to control closure tube travel, shaft rotation, articulation, or clamp arm closure, or a combination of the above. A display 473 displays a variety of operating conditions of the instruments and may include touch screen functionality for data input. Information displayed on the display 473 may be overlaid with images acquired via endoscopic imaging modules.

[0128] In one aspect, the microcontroller 461 may be any single-core or multicore processor such as those known under the trade name ARM Cortex by Texas Instruments. In one aspect, the main microcontroller 461 may be an LM4F230H5QR ARM Cortex-M4F Processor Core, available from Texas Instruments, for example, comprising an on-chip memory of 256 KB single-cycle flash memory, or other non-volatile memory, up to 40 MHz, a prefetch buffer to improve performance above 40 MHz, a 32 KB single-cycle SRAM, and internal ROM loaded with StellarisWare® software, a 2 KB EEPROM, one or more PWM modules, one or more QEI analogs, and/or one or more 12-bit ADCs with 12 analog input channels, details of which are available for the product datasheet.

[0129] In one aspect, the microcontroller 461 may comprise a safety controller comprising two controller-based families such as TMS570 and RM4x, known under the trade name Hercules ARM Cortex R4, also by Texas Instruments. The safety controller may be configured specifically for IEC 61508 and ISO 26262 safety critical applications, among others, to provide advanced integrated safety features while delivering scalable performance, connectivity, and memory options.

[0130] The microcontroller 461 may be programmed to perform various functions such as precise control over the speed and position of the knife, articulation systems, clamp arm, or a combination of the above. In one aspect, the microcontroller 461 includes a processor 462 and a memory 468. The electric motor 482 may be a brushed direct current (DC) motor with a gearbox and mechanical links to an articulation or knife system. In one aspect, a motor driver 492 may be an A3941 available from Allegro Microsystems, Inc. Other motor drivers may be readily substituted for use in the tracking system 480 comprising an absolute positioning system. A detailed description of an absolute positioning system is described in U.S. Patent Application Publication No. 2017/0296213, titled SYSTEMS AND METHODS FOR CONTROLLING A SURGICAL STAPLING AND CUTTING INSTRUMENT, which published on October 19, 2017, which is herein incorporated by reference in its entirety.

[0131] The microcontroller 461 may be programmed to provide precise control over the speed and position of displacement members and articulation systems. The microcontroller 461 may be configured to compute a response in the software of the microcontroller 461. The computed response is compared to a measured response of the actual system to obtain an “observed” response, which is used for actual feedback decisions. The observed response is a favorable, tuned value that balances the smooth, continuous nature of the simulated response with the measured response, which can detect outside influences on the system.

[0132] In one aspect, the motor 482 may be controlled by the motor driver 492 and can be employed by the firing system of the surgical instrument or tool. In various forms, the motor 482 may be a brushed DC driving motor having a maximum rotational speed of approximately 25,000 RPM. In other arrangements, the motor 482 may include a brushless motor, a cordless motor, a synchronous motor, a stepper motor, or any other suitable electric motor. The motor driver 492 may comprise an H-bridge driver comprising field-effect transistors (FETs), for example. The motor 482 can be powered by a power assembly releasably mounted to the handle assembly or tool housing for supplying control power to the surgical instrument or tool. The power assembly may comprise a battery which may include a number of battery cells connected in series that can be used as the power source to power the surgical instrument or tool. In certain circumstances, the battery cells of the power assembly may be replaceable and/or rechargeable battery cells. In at least one

example, the battery cells can be lithium-ion batteries which can be couplable to and separable from the power assembly.

[0133] The motor driver 492 may be an A3941 available from Allegro Microsystems, Inc. The A3941 492 is a full-bridge controller for use with external N-channel power metal-oxide semiconductor field-effect transistors (MOSFETs) specifically designed for inductive loads, such as brush DC motors. The driver 492 comprises a unique charge pump regulator that provides full (>10 V) gate drive for battery voltages down to 7 V and allows the A3941 to operate with a reduced gate drive, down to 5.5 V. A bootstrap capacitor may be employed to provide the above battery supply voltage required for N-channel MOSFETs. An internal charge pump for the high-side drive allows DC (100% duty cycle) operation. The full bridge can be driven in fast or slow decay modes using diode or synchronous rectification. In the slow decay mode, current recirculation can be through the high-side or the low-side FETs. The power FETs are protected from shoot-through by resistor-adjustable dead time. Integrated diagnostics provide indications of undervoltage, overtemperature, and power bridge faults and can be configured to protect the power MOSFETs under most short circuit conditions. Other motor drivers may be readily substituted for use in the tracking system 480 comprising an absolute positioning system.

[0134] The tracking system 480 comprises a controlled motor drive circuit arrangement comprising a position sensor 472 according to one aspect of this disclosure. The position sensor 472 for an absolute positioning system provides a unique position signal corresponding to the location of a displacement member. In one aspect, the displacement member represents a longitudinally movable drive member comprising a rack of drive teeth for meshing engagement with a corresponding drive gear of a gear reducer assembly. In other aspects, the displacement member represents the firing member, which could be adapted and configured to include a rack of drive teeth. In yet another aspect, the displacement member represents a longitudinal displacement member to open and close a clamp arm, which can be adapted and configured to include a rack of drive teeth. In other aspects, the displacement member represents a clamp arm closure member configured to close and to open a clamp arm of a stapler, ultrasonic, or electrosurgical device, or combinations of the above. Accordingly, as used herein, the term displacement member is used generically to refer to any movable member of the surgical instrument or tool such as the drive member, the clamp arm, or any element that can be displaced. Accordingly, the absolute positioning system can, in effect, track the displacement of the clamp arm by tracking the linear displacement of the longitudinally movable drive member. In other aspects, the absolute positioning system can be configured to track the position of a clamp arm in the process of closing or opening. In various other aspects, the displacement member may be coupled to any position sensor 472 suitable for measuring linear displacement.

Thus, the longitudinally movable drive member, or clamp arm, or combinations thereof, may be coupled to any suitable linear displacement sensor. Linear displacement sensors may include contact or non-contact displacement sensors. Linear displacement sensors may comprise linear variable differential transformers (LVDT), differential variable reluctance transducers (DVRT), a slide potentiometer, a magnetic sensing system comprising a movable magnet and a series of linearly arranged Hall effect sensors, a magnetic sensing system comprising a fixed magnet and a series of movable, linearly arranged Hall effect sensors, an optical sensing system comprising a movable light source and a series of linearly arranged photo diodes or photo detectors, an optical sensing system comprising a fixed light source and a series of movable linearly, arranged photo diodes or photo detectors, or any combination thereof.

[0135] The electric motor 482 can include a rotatable shaft that operably interfaces with a gear assembly that is mounted in meshing engagement with a set, or rack, of drive teeth on the displacement member. A sensor element may be operably coupled to a gear assembly such that a single revolution of the position sensor 472 element corresponds to some linear longitudinal translation of the displacement member. An arrangement of gearing and sensors can be connected to the linear actuator, via a rack and pinion arrangement, or a rotary actuator, via a spur gear or other connection. A power source supplies power to the absolute positioning system and an output indicator may display the output of the absolute positioning system. The displacement member represents the longitudinally movable drive member comprising a rack of drive teeth formed thereon for meshing engagement with a corresponding drive gear of the gear reducer assembly. The displacement member represents the longitudinally movable firing member to open and close a clamp arm.

[0136] A single revolution of the sensor element associated with the position sensor 472 is equivalent to a longitudinal linear displacement d_1 of the displacement member, where d_1 is the longitudinal linear distance that the displacement member moves from point "a" to point "b" after a single revolution of the sensor element coupled to the displacement member. The sensor arrangement may be connected via a gear reduction that results in the position sensor 472 completing one or more revolutions for the full stroke of the displacement member. The position sensor 472 may complete multiple revolutions for the full stroke of the displacement member.

[0137] A series of switches, where n is an integer greater than one, may be employed alone or in combination with a gear reduction to provide a unique position signal for more than one revolution of the position sensor 472. The state of the switches are fed back to the microcontroller 461 that applies logic to determine a unique position signal corresponding to the longitudinal linear displacement $d_1 + d_2 + \dots + d_n$ of the displacement member. The output of the position sensor 472 is provided to the microcontroller 461. The position sensor 472 of

the sensor arrangement may comprise a magnetic sensor, an analog rotary sensor like a potentiometer, or an array of analog Hall-effect elements, which output a unique combination of position signals or values.

[0138] The position sensor 472 may comprise any number of magnetic sensing elements, such as, for example, magnetic sensors classified according to whether they measure the total magnetic field or the vector components of the magnetic field. The techniques used to produce both types of magnetic sensors encompass many aspects of physics and electronics. The technologies used for magnetic field sensing include search coil, fluxgate, optically pumped, nuclear precession, SQUID, Hall-effect, anisotropic magnetoresistance, giant magnetoresistance, magnetic tunnel junctions, giant magnetoimpedance, magnetostrictive/piezoelectric composites, magnetodiode, magnetotransistor, fiber-optic, magneto-optic, and microelectromechanical systems-based magnetic sensors, among others.

[0139] In one aspect, the position sensor 472 for the tracking system 480 comprising an absolute positioning system comprises a magnetic rotary absolute positioning system. The position sensor 472 may be implemented as an AS5055EQFT single-chip magnetic rotary position sensor available from Austria Microsystems, AG. The position sensor 472 is interfaced with the microcontroller 461 to provide an absolute positioning system. The position sensor 472 is a low-voltage and low-power component and includes four Hall-effect elements in an area of the position sensor 472 that is located above a magnet. A high-resolution ADC and a smart power management controller are also provided on the chip. A coordinate rotation digital computer (CORDIC) processor, also known as the digit-by-digit method and Volder's algorithm, is provided to implement a simple and efficient algorithm to calculate hyperbolic and trigonometric functions that require only addition, subtraction, bitshift, and table lookup operations. The angle position, alarm bits, and magnetic field information are transmitted over a standard serial communication interface, such as a serial peripheral interface (SPI) interface, to the microcontroller 461. The position sensor 472 provides 12 or 14 bits of resolution. The position sensor 472 may be an AS5055 chip provided in a small QFN 16-pin 4x4x0.85mm package.

[0140] The tracking system 480 comprising an absolute positioning system may comprise and/or be programmed to implement a feedback controller, such as a PID, state feedback, and adaptive controller. A power source converts the signal from the feedback controller into a physical input to the system: in this case the voltage. Other examples include a PWM of the voltage, current, and force. Other sensor(s) may be provided to measure physical parameters of the physical system in addition to the position measured by the position sensor 472. In some aspects, the other sensor(s) can include sensor arrangements such as those described in U.S. Patent No. 9,345,481, titled STAPLE CARTRIDGE TISSUE

THICKNESS SENSOR SYSTEM, which issued on May 24, 2016, which is herein incorporated by reference in its entirety; U.S. Patent Application Publication No. 2014/0263552, titled STAPLE CARTRIDGE TISSUE THICKNESS SENSOR SYSTEM, which published on September 18, 2014, which is herein incorporated by reference in its entirety; and U.S. Patent Application Serial No. 15/628,175, titled TECHNIQUES FOR ADAPTIVE CONTROL OF MOTOR VELOCITY OF A SURGICAL STAPLING AND CUTTING INSTRUMENT, filed June 20, 2017, which is herein incorporated by reference in its entirety. In a digital signal processing system, an absolute positioning system is coupled to a digital data acquisition system where the output of the absolute positioning system will have a finite resolution and sampling frequency. The absolute positioning system may comprise a compare-and-combine circuit to combine a computed response with a measured response using algorithms, such as a weighted average and a theoretical control loop, that drive the computed response towards the measured response. The computed response of the physical system takes into account properties like mass, inertia, viscous friction, inductance resistance, etc., to predict what the states and outputs of the physical system will be by knowing the input.

[0141] The absolute positioning system provides an absolute position of the displacement member upon power-up of the instrument, without retracting or advancing the displacement member to a reset (zero or home) position as may be required with conventional rotary encoders that merely count the number of steps forwards or backwards that the motor 482 has taken to infer the position of a device actuator, drive bar, knife, or the like.

[0142] A sensor 474, such as, for example, a strain gauge or a micro-strain gauge, is configured to measure one or more parameters of the end effector, such as, for example, the amplitude of the strain exerted on the anvil during a clamping operation, which can be indicative of the closure forces applied to the anvil. The measured strain is converted to a digital signal and provided to the processor 462. Alternatively, or in addition to the sensor 474, a sensor 476, such as, for example, a load sensor, can measure the closure force applied by the closure drive system to the anvil in a stapler or a clamp arm in an ultrasonic or electro-surgical instrument. The sensor 476, such as, for example, a load sensor, can measure the firing force applied to a closure member coupled to a clamp arm of the surgical instrument or tool or the force applied by a clamp arm to tissue located in the jaws of an ultrasonic or electro-surgical instrument. Alternatively, a current sensor 478 can be employed to measure the current drawn by the motor 482. The displacement member also may be configured to engage a clamp arm to open or close the clamp arm. The force sensor may be configured to measure the clamping force on tissue. The force required to advance the displacement member can correspond to the current drawn by the motor 482, for example. The measured force is converted to a digital signal and provided to the processor 462.

[0143] In one form, the strain gauge sensor 474 can be used to measure the force applied to the tissue by the end effector. A strain gauge can be coupled to the end effector to measure the force on the tissue being treated by the end effector. A system for measuring forces applied to the tissue grasped by the end effector comprises a strain gauge sensor 474, such as, for example, a micro-strain gauge, that is configured to measure one or more parameters of the end effector, for example. In one aspect, the strain gauge sensor 474 can measure the amplitude or magnitude of the strain exerted on a jaw member of an end effector during a clamping operation, which can be indicative of the tissue compression. The measured strain is converted to a digital signal and provided to a processor 462 of the microcontroller 461. A load sensor 476 can measure the force used to operate the knife element, for example, to cut the tissue captured between the anvil and the staple cartridge. A load sensor 476 can measure the force used to operate the clamp arm element, for example, to capture tissue between the clamp arm and an ultrasonic blade or to capture tissue between the clamp arm and a jaw of an electrosurgical instrument. A magnetic field sensor can be employed to measure the thickness of the captured tissue. The measurement of the magnetic field sensor also may be converted to a digital signal and provided to the processor 462.

[0144] The measurements of the tissue compression, the tissue thickness, and/or the force required to close the end effector on the tissue, as respectively measured by the sensors 474, 476, can be used by the microcontroller 461 to characterize the selected position of the firing member and/or the corresponding value of the speed of the firing member. In one instance, a memory 468 may store a technique, an equation, and/or a lookup table which can be employed by the microcontroller 461 in the assessment.

[0145] The control system 470 of the surgical instrument or tool also may comprise wired or wireless communication circuits to communicate with the modular communication hub as shown in FIGS. 8–11.

[0146] FIG. 13 illustrates a control circuit 500 configured to control aspects of the surgical instrument or tool according to one aspect of this disclosure. The control circuit 500 can be configured to implement various processes described herein. The control circuit 500 may comprise a microcontroller comprising one or more processors 502 (e.g., microprocessor, microcontroller) coupled to at least one memory circuit 504. The memory circuit 504 stores machine-executable instructions that, when executed by the processor 502, cause the processor 502 to execute machine instructions to implement various processes described herein. The processor 502 may be any one of a number of single-core or multicore processors known in the art. The memory circuit 504 may comprise volatile and non-volatile storage media. The processor 502 may include an instruction processing unit 506 and an

arithmetic unit 508. The instruction processing unit may be configured to receive instructions from the memory circuit 504 of this disclosure.

[0147] FIG. 14 illustrates a combinational logic circuit 510 configured to control aspects of the surgical instrument or tool according to one aspect of this disclosure. The combinational logic circuit 510 can be configured to implement various processes described herein. The combinational logic circuit 510 may comprise a finite state machine comprising a combinational logic 512 configured to receive data associated with the surgical instrument or tool at an input 514, process the data by the combinational logic 512, and provide an output 516.

[0148] FIG. 15 illustrates a sequential logic circuit 520 configured to control aspects of the surgical instrument or tool according to one aspect of this disclosure. The sequential logic circuit 520 or the combinational logic 522 can be configured to implement various processes described herein. The sequential logic circuit 520 may comprise a finite state machine. The sequential logic circuit 520 may comprise a combinational logic 522, at least one memory circuit 524, and a clock 529, for example. The at least one memory circuit 524 can store a current state of the finite state machine. In certain instances, the sequential logic circuit 520 may be synchronous or asynchronous. The combinational logic 522 is configured to receive data associated with the surgical instrument or tool from an input 526, process the data by the combinational logic 522, and provide an output 528. In other aspects, the circuit may comprise a combination of a processor (e.g., processor 502, FIG. 13) and a finite state machine to implement various processes herein. In other aspects, the finite state machine may comprise a combination of a combinational logic circuit (e.g., combinational logic circuit 510, FIG. 14) and the sequential logic circuit 520.

[0149] FIG. 16 illustrates a surgical instrument or tool comprising a plurality of motors which can be activated to perform various functions. In certain instances, a first motor can be activated to perform a first function, a second motor can be activated to perform a second function, a third motor can be activated to perform a third function, a fourth motor can be activated to perform a fourth function, and so on. In certain instances, the plurality of motors of robotic surgical instrument 600 can be individually activated to cause firing, closure, and/or articulation motions in the end effector. The firing, closure, and/or articulation motions can be transmitted to the end effector through a shaft assembly, for example.

[0150] In certain instances, the surgical instrument system or tool may include a firing motor 602. The firing motor 602 may be operably coupled to a firing motor drive assembly 604 which can be configured to transmit firing motions, generated by the motor 602 to the end effector, in particular to displace the clamp arm closure member. The closure member may be retracted by reversing the direction of the motor 602, which also causes the clamp arm to open.

[0151] In certain instances, the surgical instrument or tool may include a closure motor 603. The closure motor 603 may be operably coupled to a closure motor drive assembly 605 which can be configured to transmit closure motions, generated by the motor 603 to the end effector, in particular to displace a closure tube to close the anvil and compress tissue between the anvil and the staple cartridge. The closure motor 603 may be operably coupled to a closure motor drive assembly 605 which can be configured to transmit closure motions, generated by the motor 603 to the end effector, in particular to displace a closure tube to close the clamp arm and compress tissue between the clamp arm and either an ultrasonic blade or jaw member of an electrosurgical device. The closure motions may cause the end effector to transition from an open configuration to an approximated configuration to capture tissue, for example. The end effector may be transitioned to an open position by reversing the direction of the motor 603.

[0152] In certain instances, the surgical instrument or tool may include one or more articulation motors 606a, 606b, for example. The motors 606a, 606b may be operably coupled to respective articulation motor drive assemblies 608a, 608b, which can be configured to transmit articulation motions generated by the motors 606a, 606b to the end effector. In certain instances, the articulation motions may cause the end effector to articulate relative to the shaft, for example.

[0153] As described above, the surgical instrument or tool may include a plurality of motors which may be configured to perform various independent functions. In certain instances, the plurality of motors of the surgical instrument or tool can be individually or separately activated to perform one or more functions while the other motors remain inactive. For example, the articulation motors 606a, 606b can be activated to cause the end effector to be articulated while the firing motor 602 remains inactive. Alternatively, the firing motor 602 can be activated to fire the plurality of staples, and/or to advance the cutting edge, while the articulation motor 606 remains inactive. Furthermore, the closure motor 603 may be activated simultaneously with the firing motor 602 to cause the closure tube or closure member to advance distally as described in more detail hereinbelow.

[0154] In certain instances, the surgical instrument or tool may include a common control module 610 which can be employed with a plurality of motors of the surgical instrument or tool. In certain instances, the common control module 610 may accommodate one of the plurality of motors at a time. For example, the common control module 610 can be couplable to and separable from the plurality of motors of the robotic surgical instrument individually. In certain instances, a plurality of the motors of the surgical instrument or tool may share one or more common control modules such as the common control module 610. In certain instances, a plurality of motors of the surgical instrument or tool can be individually and selectively engaged with the common control module 610. In certain instances, the common

control module 610 can be selectively switched from interfacing with one of a plurality of motors of the surgical instrument or tool to interfacing with another one of the plurality of motors of the surgical instrument or tool.

[0155] In at least one example, the common control module 610 can be selectively switched between operable engagement with the articulation motors 606a, 606b and operable engagement with either the firing motor 602 or the closure motor 603. In at least one example, as illustrated in FIG. 16, a switch 614 can be moved or transitioned between a plurality of positions and/or states. In a first position 616, the switch 614 may electrically couple the common control module 610 to the firing motor 602; in a second position 617, the switch 614 may electrically couple the common control module 610 to the closure motor 603; in a third position 618a, the switch 614 may electrically couple the common control module 610 to the first articulation motor 606a; and in a fourth position 618b, the switch 614 may electrically couple the common control module 610 to the second articulation motor 606b, for example. In certain instances, separate common control modules 610 can be electrically coupled to the firing motor 602, the closure motor 603, and the articulations motor 606a, 606b at the same time. In certain instances, the switch 614 may be a mechanical switch, an electromechanical switch, a solid-state switch, or any suitable switching mechanism.

[0156] Each of the motors 602, 603, 606a, 606b may comprise a torque sensor to measure the output torque on the shaft of the motor. The force on an end effector may be sensed in any conventional manner, such as by force sensors on the outer sides of the jaws or by a torque sensor for the motor actuating the jaws.

[0157] In various instances, as illustrated in FIG. 16, the common control module 610 may comprise a motor driver 626 which may comprise one or more H-Bridge FETs. The motor driver 626 may modulate the power transmitted from a power source 628 to a motor coupled to the common control module 610 based on input from a microcontroller 620 (the “controller”), for example. In certain instances, the microcontroller 620 can be employed to determine the current drawn by the motor, for example, while the motor is coupled to the common control module 610, as described above.

[0158] In certain instances, the microcontroller 620 may include a microprocessor 622 (the “processor”) and one or more non-transitory computer-readable mediums or memory units 624 (the “memory”). In certain instances, the memory 624 may store various program instructions, which when executed may cause the processor 622 to perform a plurality of functions and/or calculations described herein. In certain instances, one or more of the memory units 624 may be coupled to the processor 622, for example. In various aspects, the microcontroller 620 may communicate over a wired or wireless channel, or combinations thereof.

[0159] In certain instances, the power source 628 can be employed to supply power to the microcontroller 620, for example. In certain instances, the power source 628 may comprise a battery (or “battery pack” or “power pack”), such as a lithium-ion battery, for example. In certain instances, the battery pack may be configured to be releasably mounted to a handle for supplying power to the surgical instrument 600. A number of battery cells connected in series may be used as the power source 628. In certain instances, the power source 628 may be replaceable and/or rechargeable, for example.

[0160] In various instances, the processor 622 may control the motor driver 626 to control the position, direction of rotation, and/or velocity of a motor that is coupled to the common control module 610. In certain instances, the processor 622 can signal the motor driver 626 to stop and/or disable a motor that is coupled to the common control module 610. It should be understood that the term “processor” as used herein includes any suitable microprocessor, microcontroller, or other basic computing device that incorporates the functions of a computer’s central processing unit (CPU) on an integrated circuit or, at most, a few integrated circuits. The processor 622 is a multipurpose, programmable device that accepts digital data as input, processes it according to instructions stored in its memory, and provides results as output. It is an example of sequential digital logic, as it has internal memory. Processors operate on numbers and symbols represented in the binary numeral system.

[0161] In one instance, the processor 622 may be any single-core or multicore processor such as those known under the trade name ARM Cortex by Texas Instruments. In certain instances, the microcontroller 620 may be an LM 4F230H5QR, available from Texas Instruments, for example. In at least one example, the Texas Instruments LM4F230H5QR is an ARM Cortex-M4F Processor Core comprising an on-chip memory of 256 KB single-cycle flash memory, or other non-volatile memory, up to 40 MHz, a prefetch buffer to improve performance above 40 MHz, a 32 KB single-cycle SRAM, an internal ROM loaded with StellarisWare® software, a 2 KB EEPROM, one or more PWM modules, one or more QEI analogs, one or more 12-bit ADCs with 12 analog input channels, among other features that are readily available for the product datasheet. Other microcontrollers may be readily substituted for use with the module 4410. Accordingly, the present disclosure should not be limited in this context.

[0162] In certain instances, the memory 624 may include program instructions for controlling each of the motors of the surgical instrument 600 that are couplable to the common control module 610. For example, the memory 624 may include program instructions for controlling the firing motor 602, the closure motor 603, and the articulation motors 606a, 606b. Such program instructions may cause the processor 622 to control the

firing, closure, and articulation functions in accordance with inputs from algorithms or control programs of the surgical instrument or tool.

[0163] In certain instances, one or more mechanisms and/or sensors such as, for example, sensors 630 can be employed to alert the processor 622 to the program instructions that should be used in a particular setting. For example, the sensors 630 may alert the processor 622 to use the program instructions associated with firing, closing, and articulating the end effector. In certain instances, the sensors 630 may comprise position sensors which can be employed to sense the position of the switch 614, for example. Accordingly, the processor 622 may use the program instructions associated with firing the closure member coupled to the clamp arm of the end effector upon detecting, through the sensors 630 for example, that the switch 614 is in the first position 616; the processor 622 may use the program instructions associated with closing the anvil upon detecting, through the sensors 630 for example, that the switch 614 is in the second position 617; and the processor 622 may use the program instructions associated with articulating the end effector upon detecting, through the sensors 630 for example, that the switch 614 is in the third or fourth position 618a, 618b.

[0164] FIG. 17 is a schematic diagram of a robotic surgical instrument 700 configured to operate a surgical tool described herein according to one aspect of this disclosure. The robotic surgical instrument 700 may be programmed or configured to control distal/proximal translation of a displacement member, distal/proximal displacement of a closure tube, shaft rotation, and articulation, either with single or multiple articulation drive links. In one aspect, the surgical instrument 700 may be programmed or configured to individually control a firing member, a closure member, a shaft member, or one or more articulation members, or combinations thereof. The surgical instrument 700 comprises a control circuit 710 configured to control motor-driven firing members, closure members, shaft members, or one or more articulation members, or combinations thereof.

[0165] In one aspect, the robotic surgical instrument 700 comprises a control circuit 710 configured to control a clamp arm 716 and a closure member 714 portion of an end effector 702, an ultrasonic blade 718 coupled to an ultrasonic transducer 719 excited by an ultrasonic generator 721, a shaft 740, and one or more articulation members 742a, 742b via a plurality of motors 704a-704e. A position sensor 734 may be configured to provide position feedback of the closure member 714 to the control circuit 710. Other sensors 738 may be configured to provide feedback to the control circuit 710. A timer/counter 731 provides timing and counting information to the control circuit 710. An energy source 712 may be provided to operate the motors 704a-704e, and a current sensor 736 provides motor current feedback to the control circuit 710. The motors 704a-704e can be operated individually by the control circuit 710 in an open-loop or closed-loop feedback control.

[0166] In one aspect, the control circuit 710 may comprise one or more microcontrollers, microprocessors, or other suitable processors for executing instructions that cause the processor or processors to perform one or more tasks. In one aspect, a timer/counter 731 provides an output signal, such as the elapsed time or a digital count, to the control circuit 710 to correlate the position of the closure member 714 as determined by the position sensor 734 with the output of the timer/counter 731 such that the control circuit 710 can determine the position of the closure member 714 at a specific time (t) relative to a starting position or the time (t) when the closure member 714 is at a specific position relative to a starting position. The timer/counter 731 may be configured to measure elapsed time, count external events, or time external events.

[0167] In one aspect, the control circuit 710 may be programmed to control functions of the end effector 702 based on one or more tissue conditions. The control circuit 710 may be programmed to sense tissue conditions, such as thickness, either directly or indirectly, as described herein. The control circuit 710 may be programmed to select a firing control program or closure control program based on tissue conditions. A firing control program may describe the distal motion of the displacement member. Different firing control programs may be selected to better treat different tissue conditions. For example, when thicker tissue is present, the control circuit 710 may be programmed to translate the displacement member at a lower velocity and/or with lower power. When thinner tissue is present, the control circuit 710 may be programmed to translate the displacement member at a higher velocity and/or with higher power. A closure control program may control the closure force applied to the tissue by the clamp arm 716. Other control programs control the rotation of the shaft 740 and the articulation members 742a, 742b.

[0168] In one aspect, the control circuit 710 may generate motor set point signals. The motor set point signals may be provided to various motor controllers 708a-708e. The motor controllers 708a-708e may comprise one or more circuits configured to provide motor drive signals to the motors 704a-704e to drive the motors 704a-704e as described herein. In some examples, the motors 704a-704e may be brushed DC electric motors. For example, the velocity of the motors 704a-704e may be proportional to the respective motor drive signals. In some examples, the motors 704a-704e may be brushless DC electric motors, and the respective motor drive signals may comprise a PWM signal provided to one or more stator windings of the motors 704a-704e. Also, in some examples, the motor controllers 708a-708e may be omitted and the control circuit 710 may generate the motor drive signals directly.

[0169] In one aspect, the control circuit 710 may initially operate each of the motors 704a-704e in an open-loop configuration for a first open-loop portion of a stroke of the displacement member. Based on the response of the robotic surgical instrument 700 during the open-loop portion of the stroke, the control circuit 710 may select a firing control program

in a closed-loop configuration. The response of the instrument may include a translation distance of the displacement member during the open-loop portion, a time elapsed during the open-loop portion, the energy provided to one of the motors 704a-704e during the open-loop portion, a sum of pulse widths of a motor drive signal, etc. After the open-loop portion, the control circuit 710 may implement the selected firing control program for a second portion of the displacement member stroke. For example, during a closed-loop portion of the stroke, the control circuit 710 may modulate one of the motors 704a-704e based on translation data describing a position of the displacement member in a closed-loop manner to translate the displacement member at a constant velocity.

[0170] In one aspect, the motors 704a-704e may receive power from an energy source 712. The energy source 712 may be a DC power supply driven by a main alternating current power source, a battery, a super capacitor, or any other suitable energy source. The motors 704a-704e may be mechanically coupled to individual movable mechanical elements such as the closure member 714, clamp arm 716, shaft 740, articulation 742a, and articulation 742b via respective transmissions 706a-706e. The transmissions 706a-706e may include one or more gears or other linkage components to couple the motors 704a-704e to movable mechanical elements. A position sensor 734 may sense a position of the closure member 714. The position sensor 734 may be or include any type of sensor that is capable of generating position data that indicate a position of the closure member 714. In some examples, the position sensor 734 may include an encoder configured to provide a series of pulses to the control circuit 710 as the closure member 714 translates distally and proximally. The control circuit 710 may track the pulses to determine the position of the closure member 714. Other suitable position sensors may be used, including, for example, a proximity sensor. Other types of position sensors may provide other signals indicating motion of the closure member 714. Also, in some examples, the position sensor 734 may be omitted. Where any of the motors 704a-704e is a stepper motor, the control circuit 710 may track the position of the closure member 714 by aggregating the number and direction of steps that the motor 704 has been instructed to execute. The position sensor 734 may be located in the end effector 702 or at any other portion of the instrument. The outputs of each of the motors 704a-704e include a torque sensor 744a-744e to sense force and have an encoder to sense rotation of the drive shaft.

[0171] In one aspect, the control circuit 710 is configured to drive a firing member such as the closure member 714 portion of the end effector 702. The control circuit 710 provides a motor set point to a motor control 708a, which provides a drive signal to the motor 704a. The output shaft of the motor 704a is coupled to a torque sensor 744a. The torque sensor 744a is coupled to a transmission 706a which is coupled to the closure member 714. The transmission 706a comprises movable mechanical elements such as rotating elements and

a firing member to control the movement of the closure member 714 distally and proximally along a longitudinal axis of the end effector 702. In one aspect, the motor 704a may be coupled to the knife gear assembly, which includes a knife gear reduction set that includes a first knife drive gear and a second knife drive gear. A torque sensor 744a provides a firing force feedback signal to the control circuit 710. The firing force signal represents the force required to fire or displace the closure member 714. A position sensor 734 may be configured to provide the position of the closure member 714 along the firing stroke or the position of the firing member as a feedback signal to the control circuit 710. The end effector 702 may include additional sensors 738 configured to provide feedback signals to the control circuit 710. When ready to use, the control circuit 710 may provide a firing signal to the motor control 708a. In response to the firing signal, the motor 704a may drive the firing member distally along the longitudinal axis of the end effector 702 from a proximal stroke start position to a stroke end position distal to the stroke start position. As the closure member 714 translates distally, the clamp arm 716 closes towards the ultrasonic blade 718.

[0172] In one aspect, the control circuit 710 is configured to drive a closure member such as the clamp arm 716 portion of the end effector 702. The control circuit 710 provides a motor set point to a motor control 708b, which provides a drive signal to the motor 704b. The output shaft of the motor 704b is coupled to a torque sensor 744b. The torque sensor 744b is coupled to a transmission 706b which is coupled to the clamp arm 716. The transmission 706b comprises movable mechanical elements such as rotating elements and a closure member to control the movement of the clamp arm 716 from the open and closed positions. In one aspect, the motor 704b is coupled to a closure gear assembly, which includes a closure reduction gear set that is supported in meshing engagement with the closure spur gear. The torque sensor 744b provides a closure force feedback signal to the control circuit 710. The closure force feedback signal represents the closure force applied to the clamp arm 716. The position sensor 734 may be configured to provide the position of the closure member as a feedback signal to the control circuit 710. Additional sensors 738 in the end effector 702 may provide the closure force feedback signal to the control circuit 710. The pivotable clamp arm 716 is positioned opposite the ultrasonic blade 718. When ready to use, the control circuit 710 may provide a closure signal to the motor control 708b. In response to the closure signal, the motor 704b advances a closure member to grasp tissue between the clamp arm 716 and the ultrasonic blade 718.

[0173] In one aspect, the control circuit 710 is configured to rotate a shaft member such as the shaft 740 to rotate the end effector 702. The control circuit 710 provides a motor set point to a motor control 708c, which provides a drive signal to the motor 704c. The output shaft of the motor 704c is coupled to a torque sensor 744c. The torque sensor 744c is coupled to a transmission 706c which is coupled to the shaft 740. The transmission 706c

comprises movable mechanical elements such as rotating elements to control the rotation of the shaft 740 clockwise or counterclockwise up to and over 360°. In one aspect, the motor 704c is coupled to the rotational transmission assembly, which includes a tube gear segment that is formed on (or attached to) the proximal end of the proximal closure tube for operable engagement by a rotational gear assembly that is operably supported on the tool mounting plate. The torque sensor 744c provides a rotation force feedback signal to the control circuit 710. The rotation force feedback signal represents the rotation force applied to the shaft 740. The position sensor 734 may be configured to provide the position of the closure member as a feedback signal to the control circuit 710. Additional sensors 738 such as a shaft encoder may provide the rotational position of the shaft 740 to the control circuit 710.

[0174] In one aspect, the control circuit 710 is configured to articulate the end effector 702. The control circuit 710 provides a motor set point to a motor control 708d, which provides a drive signal to the motor 704d. The output shaft of the motor 704d is coupled to a torque sensor 744d. The torque sensor 744d is coupled to a transmission 706d which is coupled to an articulation member 742a. The transmission 706d comprises movable mechanical elements such as articulation elements to control the articulation of the end effector 702 $\pm 65^\circ$. In one aspect, the motor 704d is coupled to an articulation nut, which is rotatably journaled on the proximal end portion of the distal spine portion and is rotatably driven thereon by an articulation gear assembly. The torque sensor 744d provides an articulation force feedback signal to the control circuit 710. The articulation force feedback signal represents the articulation force applied to the end effector 702. Sensors 738, such as an articulation encoder, may provide the articulation position of the end effector 702 to the control circuit 710.

[0175] In another aspect, the articulation function of the robotic surgical system 700 may comprise two articulation members, or links, 742a, 742b. These articulation members 742a, 742b are driven by separate disks on the robot interface (the rack) which are driven by the two motors 708d, 708e. When the separate firing motor 704a is provided, each of articulation links 742a, 742b can be antagonistically driven with respect to the other link in order to provide a resistive holding motion and a load to the head when it is not moving and to provide an articulation motion as the head is articulated. The articulation members 742a, 742b attach to the head at a fixed radius as the head is rotated. Accordingly, the mechanical advantage of the push-and-pull link changes as the head is rotated. This change in the mechanical advantage may be more pronounced with other articulation link drive systems.

[0176] In one aspect, the one or more motors 704a-704e may comprise a brushed DC motor with a gearbox and mechanical links to a firing member, closure member, or articulation member. Another example includes electric motors 704a-704e that operate the movable mechanical elements such as the displacement member, articulation links, closure

tube, and shaft. An outside influence is an unmeasured, unpredictable influence of things like tissue, surrounding bodies, and friction on the physical system. Such outside influence can be referred to as drag, which acts in opposition to one of electric motors 704a-704e. The outside influence, such as drag, may cause the operation of the physical system to deviate from a desired operation of the physical system.

[0177] In one aspect, the position sensor 734 may be implemented as an absolute positioning system. In one aspect, the position sensor 734 may comprise a magnetic rotary absolute positioning system implemented as an AS5055EQFT single-chip magnetic rotary position sensor available from Austria Microsystems, AG. The position sensor 734 may interface with the control circuit 710 to provide an absolute positioning system. The position may include multiple Hall-effect elements located above a magnet and coupled to a CORDIC processor, also known as the digit-by-digit method and Volder's algorithm, that is provided to implement a simple and efficient algorithm to calculate hyperbolic and trigonometric functions that require only addition, subtraction, bitshift, and table lookup operations.

[0178] In one aspect, the control circuit 710 may be in communication with one or more sensors 738. The sensors 738 may be positioned on the end effector 702 and adapted to operate with the robotic surgical instrument 700 to measure the various derived parameters such as the gap distance versus time, tissue compression versus time, and anvil strain versus time. The sensors 738 may comprise a magnetic sensor, a magnetic field sensor, a strain gauge, a load cell, a pressure sensor, a force sensor, a torque sensor, an inductive sensor such as an eddy current sensor, a resistive sensor, a capacitive sensor, an optical sensor, and/or any other suitable sensor for measuring one or more parameters of the end effector 702. The sensors 738 may include one or more sensors. The sensors 738 may be located on the clamp arm 716 to determine tissue location using segmented electrodes. The torque sensors 744a-744e may be configured to sense force such as firing force, closure force, and/or articulation force, among others. Accordingly, the control circuit 710 can sense (1) the closure load experienced by the distal closure tube and its position, (2) the firing member at the rack and its position, (3) what portion of the ultrasonic blade 718 has tissue on it, and (4) the load and position on both articulation rods.

[0179] In one aspect, the one or more sensors 738 may comprise a strain gauge, such as a micro-strain gauge, configured to measure the magnitude of the strain in the clamp arm 716 during a clamped condition. The strain gauge provides an electrical signal whose amplitude varies with the magnitude of the strain. The sensors 738 may comprise a pressure sensor configured to detect a pressure generated by the presence of compressed tissue between the clamp arm 716 and the ultrasonic blade 718. The sensors 738 may be configured to detect impedance of a tissue section located between the clamp arm 716 and

the ultrasonic blade 718 that is indicative of the thickness and/or fullness of tissue located therebetween.

[0180] In one aspect, the sensors 738 may be implemented as one or more limit switches, electromechanical devices, solid-state switches, Hall-effect devices, magneto-resistive (MR) devices, giant magneto-resistive (GMR) devices, magnetometers, among others. In other implementations, the sensors 738 may be implemented as solid-state switches that operate under the influence of light, such as optical sensors, IR sensors, ultraviolet sensors, among others. Still, the switches may be solid-state devices such as transistors (e.g., FET, junction FET, MOSFET, bipolar, and the like). In other implementations, the sensors 738 may include electrical conductorless switches, ultrasonic switches, accelerometers, and inertial sensors, among others.

[0181] In one aspect, the sensors 738 may be configured to measure forces exerted on the clamp arm 716 by the closure drive system. For example, one or more sensors 738 can be at an interaction point between the closure tube and the clamp arm 716 to detect the closure forces applied by the closure tube to the clamp arm 716. The forces exerted on the clamp arm 716 can be representative of the tissue compression experienced by the tissue section captured between the clamp arm 716 and the ultrasonic blade 718. The one or more sensors 738 can be positioned at various interaction points along the closure drive system to detect the closure forces applied to the clamp arm 716 by the closure drive system. The one or more sensors 738 may be sampled in real time during a clamping operation by the processor of the control circuit 710. The control circuit 710 receives real-time sample measurements to provide and analyze time-based information and assess, in real time, closure forces applied to the clamp arm 716.

[0182] In one aspect, a current sensor 736 can be employed to measure the current drawn by each of the motors 704a-704e. The force required to advance any of the movable mechanical elements such as the closure member 714 corresponds to the current drawn by one of the motors 704a-704e. The force is converted to a digital signal and provided to the control circuit 710. The control circuit 710 can be configured to simulate the response of the actual system of the instrument in the software of the controller. A displacement member can be actuated to move the closure member 714 in the end effector 702 at or near a target velocity. The robotic surgical instrument 700 can include a feedback controller, which can be one of any feedback controllers, including, but not limited to a PID, a state feedback, a linear-quadratic (LQR), and/or an adaptive controller, for example. The robotic surgical instrument 700 can include a power source to convert the signal from the feedback controller into a physical input such as case voltage, PWM voltage, frequency modulated voltage, current, torque, and/or force, for example. Additional details are disclosed in U.S. Patent Application Serial No. 15/636,829, titled CLOSED LOOP VELOCITY CONTROL

TECHNIQUES FOR ROBOTIC SURGICAL INSTRUMENT, filed June 29, 2017, which is herein incorporated by reference in its entirety.

[0183] FIG. 18 illustrates a schematic diagram of a surgical instrument 750 configured to control the distal translation of a displacement member according to one aspect of this disclosure. In one aspect, the surgical instrument 750 is programmed to control the distal translation of a displacement member such as the closure member 764. The surgical instrument 750 comprises an end effector 752 that may comprise a clamp arm 766, a closure member 764, and an ultrasonic blade 768 coupled to an ultrasonic transducer 769 driven by an ultrasonic generator 771.

[0184] The position, movement, displacement, and/or translation of a linear displacement member, such as the closure member 764, can be measured by an absolute positioning system, sensor arrangement, and position sensor 784. Because the closure member 764 is coupled to a longitudinally movable drive member, the position of the closure member 764 can be determined by measuring the position of the longitudinally movable drive member employing the position sensor 784. Accordingly, in the following description, the position, displacement, and/or translation of the closure member 764 can be achieved by the position sensor 784 as described herein. A control circuit 760 may be programmed to control the translation of the displacement member, such as the closure member 764. The control circuit 760, in some examples, may comprise one or more microcontrollers, microprocessors, or other suitable processors for executing instructions that cause the processor or processors to control the displacement member, e.g., the closure member 764, in the manner described. In one aspect, a timer/counter 781 provides an output signal, such as the elapsed time or a digital count, to the control circuit 760 to correlate the position of the closure member 764 as determined by the position sensor 784 with the output of the timer/counter 781 such that the control circuit 760 can determine the position of the closure member 764 at a specific time (t) relative to a starting position. The timer/counter 781 may be configured to measure elapsed time, count external events, or time external events.

[0185] The control circuit 760 may generate a motor set point signal 772. The motor set point signal 772 may be provided to a motor controller 758. The motor controller 758 may comprise one or more circuits configured to provide a motor drive signal 774 to the motor 754 to drive the motor 754 as described herein. In some examples, the motor 754 may be a brushed DC electric motor. For example, the velocity of the motor 754 may be proportional to the motor drive signal 774. In some examples, the motor 754 may be a brushless DC electric motor and the motor drive signal 774 may comprise a PWM signal provided to one or more stator windings of the motor 754. Also, in some examples, the motor controller 758 may be omitted, and the control circuit 760 may generate the motor drive signal 774 directly.

[0186] The motor 754 may receive power from an energy source 762. The energy source 762 may be or include a battery, a super capacitor, or any other suitable energy source. The motor 754 may be mechanically coupled to the closure member 764 via a transmission 756. The transmission 756 may include one or more gears or other linkage components to couple the motor 754 to the closure member 764. A position sensor 784 may sense a position of the closure member 764. The position sensor 784 may be or include any type of sensor that is capable of generating position data that indicate a position of the closure member 764. In some examples, the position sensor 784 may include an encoder configured to provide a series of pulses to the control circuit 760 as the closure member 764 translates distally and proximally. The control circuit 760 may track the pulses to determine the position of the closure member 764. Other suitable position sensors may be used, including, for example, a proximity sensor. Other types of position sensors may provide other signals indicating motion of the closure member 764. Also, in some examples, the position sensor 784 may be omitted. Where the motor 754 is a stepper motor, the control circuit 760 may track the position of the closure member 764 by aggregating the number and direction of steps that the motor 754 has been instructed to execute. The position sensor 784 may be located in the end effector 752 or at any other portion of the instrument.

[0187] The control circuit 760 may be in communication with one or more sensors 788. The sensors 788 may be positioned on the end effector 752 and adapted to operate with the surgical instrument 750 to measure the various derived parameters such as gap distance versus time, tissue compression versus time, and anvil strain versus time. The sensors 788 may comprise a magnetic sensor, a magnetic field sensor, a strain gauge, a pressure sensor, a force sensor, an inductive sensor such as an eddy current sensor, a resistive sensor, a capacitive sensor, an optical sensor, and/or any other suitable sensor for measuring one or more parameters of the end effector 752. The sensors 788 may include one or more sensors.

[0188] The one or more sensors 788 may comprise a strain gauge, such as a micro-strain gauge, configured to measure the magnitude of the strain in the clamp arm 766 during a clamped condition. The strain gauge provides an electrical signal whose amplitude varies with the magnitude of the strain. The sensors 788 may comprise a pressure sensor configured to detect a pressure generated by the presence of compressed tissue between the clamp arm 766 and the ultrasonic blade 768. The sensors 788 may be configured to detect impedance of a tissue section located between the clamp arm 766 and the ultrasonic blade 768 that is indicative of the thickness and/or fullness of tissue located therebetween.

[0189] The sensors 788 may be is configured to measure forces exerted on the clamp arm 766 by a closure drive system. For example, one or more sensors 788 can be at an interaction point between a closure tube and the clamp arm 766 to detect the closure forces

applied by a closure tube to the clamp arm 766. The forces exerted on the clamp arm 766 can be representative of the tissue compression experienced by the tissue section captured between the clamp arm 766 and the ultrasonic blade 768. The one or more sensors 788 can be positioned at various interaction points along the closure drive system to detect the closure forces applied to the clamp arm 766 by the closure drive system. The one or more sensors 788 may be sampled in real time during a clamping operation by a processor of the control circuit 760. The control circuit 760 receives real-time sample measurements to provide and analyze time-based information and assess, in real time, closure forces applied to the clamp arm 766.

[0190] A current sensor 786 can be employed to measure the current drawn by the motor 754. The force required to advance the closure member 764 corresponds to the current drawn by the motor 754. The force is converted to a digital signal and provided to the control circuit 760.

[0191] The control circuit 760 can be configured to simulate the response of the actual system of the instrument in the software of the controller. A displacement member can be actuated to move a closure member 764 in the end effector 752 at or near a target velocity. The surgical instrument 750 can include a feedback controller, which can be one of any feedback controllers, including, but not limited to a PID, a state feedback, LQR, and/or an adaptive controller, for example. The surgical instrument 750 can include a power source to convert the signal from the feedback controller into a physical input such as case voltage, PWM voltage, frequency modulated voltage, current, torque, and/or force, for example.

[0192] The actual drive system of the surgical instrument 750 is configured to drive the displacement member, cutting member, or closure member 764, by a brushed DC motor with gearbox and mechanical links to an articulation and/or knife system. Another example is the electric motor 754 that operates the displacement member and the articulation driver, for example, of an interchangeable shaft assembly. An outside influence is an unmeasured, unpredictable influence of things like tissue, surrounding bodies and friction on the physical system. Such outside influence can be referred to as drag which acts in opposition to the electric motor 754. The outside influence, such as drag, may cause the operation of the physical system to deviate from a desired operation of the physical system.

[0193] Various example aspects are directed to a surgical instrument 750 comprising an end effector 752 with motor-driven surgical sealing and cutting implements. For example, a motor 754 may drive a displacement member distally and proximally along a longitudinal axis of the end effector 752. The end effector 752 may comprise a pivotable clamp arm 766 and, when configured for use, an ultrasonic blade 768 positioned opposite the clamp arm 766. A clinician may grasp tissue between the clamp arm 766 and the ultrasonic blade 768, as described herein. When ready to use the instrument 750, the clinician may provide a firing

signal, for example by depressing a trigger of the instrument 750. In response to the firing signal, the motor 754 may drive the displacement member distally along the longitudinal axis of the end effector 752 from a proximal stroke begin position to a stroke end position distal of the stroke begin position. As the displacement member translates distally, the closure member 764 with a cutting element positioned at a distal end, may cut the tissue between the ultrasonic blade 768 and the clamp arm 766.

[0194] In various examples, the surgical instrument 750 may comprise a control circuit 760 programmed to control the distal translation of the displacement member, such as the closure member 764, for example, based on one or more tissue conditions. The control circuit 760 may be programmed to sense tissue conditions, such as thickness, either directly or indirectly, as described herein. The control circuit 760 may be programmed to select a control program based on tissue conditions. A control program may describe the distal motion of the displacement member. Different control programs may be selected to better treat different tissue conditions. For example, when thicker tissue is present, the control circuit 760 may be programmed to translate the displacement member at a lower velocity and/or with lower power. When thinner tissue is present, the control circuit 760 may be programmed to translate the displacement member at a higher velocity and/or with higher power.

[0195] In some examples, the control circuit 760 may initially operate the motor 754 in an open loop configuration for a first open loop portion of a stroke of the displacement member. Based on a response of the instrument 750 during the open loop portion of the stroke, the control circuit 760 may select a firing control program. The response of the instrument may include, a translation distance of the displacement member during the open loop portion, a time elapsed during the open loop portion, energy provided to the motor 754 during the open loop portion, a sum of pulse widths of a motor drive signal, etc. After the open loop portion, the control circuit 760 may implement the selected firing control program for a second portion of the displacement member stroke. For example, during the closed loop portion of the stroke, the control circuit 760 may modulate the motor 754 based on translation data describing a position of the displacement member in a closed loop manner to translate the displacement member at a constant velocity. Additional details are disclosed in U.S. Patent Application Serial No. 15/720,852, titled SYSTEM AND METHODS FOR CONTROLLING A DISPLAY OF A SURGICAL INSTRUMENT, filed September 29, 2017, which is herein incorporated by reference in its entirety.

[0196] FIG. 19 is a schematic diagram of a surgical instrument 790 configured to control various functions according to one aspect of this disclosure. In one aspect, the surgical instrument 790 is programmed to control distal translation of a displacement member such as the closure member 764. The surgical instrument 790 comprises an end effector 792 that

may comprise a clamp arm 766, a closure member 764, and an ultrasonic blade 768 which may be interchanged with or work in conjunction with one or more RF electrodes 796 (shown in dashed line). The ultrasonic blade 768 is coupled to an ultrasonic transducer 769 driven by an ultrasonic generator 771.

[0197] In one aspect, sensors 788 may be implemented as a limit switch, electromechanical device, solid-state switches, Hall-effect devices, MR devices, GMR devices, magnetometers, among others. In other implementations, the sensors 638 may be solid-state switches that operate under the influence of light, such as optical sensors, IR sensors, ultraviolet sensors, among others. Still, the switches may be solid-state devices such as transistors (e.g., FET, junction FET, MOSFET, bipolar, and the like). In other implementations, the sensors 788 may include electrical conductorless switches, ultrasonic switches, accelerometers, and inertial sensors, among others.

[0198] In one aspect, the position sensor 784 may be implemented as an absolute positioning system comprising a magnetic rotary absolute positioning system implemented as an AS5055EQFT single-chip magnetic rotary position sensor available from Austria Microsystems, AG. The position sensor 784 may interface with the control circuit 760 to provide an absolute positioning system. The position may include multiple Hall-effect elements located above a magnet and coupled to a CORDIC processor, also known as the digit-by-digit method and Volder's algorithm, that is provided to implement a simple and efficient algorithm to calculate hyperbolic and trigonometric functions that require only addition, subtraction, bitshift, and table lookup operations.

[0199] In some examples, the position sensor 784 may be omitted. Where the motor 754 is a stepper motor, the control circuit 760 may track the position of the closure member 764 by aggregating the number and direction of steps that the motor has been instructed to execute. The position sensor 784 may be located in the end effector 792 or at any other portion of the instrument.

[0200] The control circuit 760 may be in communication with one or more sensors 788. The sensors 788 may be positioned on the end effector 792 and adapted to operate with the surgical instrument 790 to measure the various derived parameters such as gap distance versus time, tissue compression versus time, and anvil strain versus time. The sensors 788 may comprise a magnetic sensor, a magnetic field sensor, a strain gauge, a pressure sensor, a force sensor, an inductive sensor such as an eddy current sensor, a resistive sensor, a capacitive sensor, an optical sensor, and/or any other suitable sensor for measuring one or more parameters of the end effector 792. The sensors 788 may include one or more sensors.

[0201] An RF energy source 794 is coupled to the end effector 792 and is applied to the RF electrode 796 when the RF electrode 796 is provided in the end effector 792 in place of

the ultrasonic blade 768 or to work in conjunction with the ultrasonic blade 768. For example, the ultrasonic blade is made of electrically conductive metal and may be employed as the return path for electrosurgical RF current. The control circuit 760 controls the delivery of the RF energy to the RF electrode 796.

[0202] Additional details are disclosed in U.S. Patent Application Serial No. 15/636,096, titled SURGICAL SYSTEM COUPLABLE WITH STAPLE CARTRIDGE AND RADIO FREQUENCY CARTRIDGE, AND METHOD OF USING SAME, filed June 28, 2017, which is herein incorporated by reference in its entirety.

Generator Hardware

[0203] In various aspects smart ultrasonic energy devices may comprise adaptive algorithms to control the operation of the ultrasonic blade. In one aspect, the ultrasonic blade adaptive control algorithms are configured to identify tissue type and adjust device parameters. In one aspect, the ultrasonic blade control algorithms are configured to parameterize tissue type. An algorithm to detect the collagen/elastic ratio of tissue to tune the amplitude of the distal tip of the ultrasonic blade is described in the following section of the present disclosure. Various aspects of smart ultrasonic energy devices are described herein in connection with FIGS. 12–19, for example. Accordingly, the following description of adaptive ultrasonic blade control algorithms should be read in conjunction with FIGS. 12–19 and the description associated therewith.

[0204] In certain surgical procedures it would be desirable to employ adaptive ultrasonic blade control algorithms. In one aspect, adaptive ultrasonic blade control algorithms may be employed to adjust the parameters of the ultrasonic device based on the type of tissue in contact with the ultrasonic blade. In one aspect, the parameters of the ultrasonic device may be adjusted based on the location of the tissue within the jaws of the ultrasonic end effector, for example, the location of the tissue between the clamp arm and the ultrasonic blade. The impedance of the ultrasonic transducer may be employed to differentiate what percentage of the tissue is located in the distal or proximal end of the end effector. The reactions of the ultrasonic device may be based on the tissue type or compressibility of the tissue. In another aspect, the parameters of the ultrasonic device may be adjusted based on the identified tissue type or parameterization. For example, the mechanical displacement amplitude of the distal tip of the ultrasonic blade may be tuned based on the ration of collagen to elastin tissue detected during the tissue identification procedure. The ratio of collagen to elastin tissue may be detected used a variety of techniques including infrared (IR) surface reflectance and emissivity. The force applied to the tissue by the clamp arm and/or the stroke of the clamp arm to produce gap and compression. Electrical continuity across a jaw

equipped with electrodes may be employed to determine what percentage of the jaw is covered with tissue.

[0205] FIG. 20 is a system 800 configured to execute adaptive ultrasonic blade control algorithms in a surgical data network comprising a modular communication hub, in accordance with at least one aspect of the present disclosure. In one aspect, the generator module 240 is configured to execute the adaptive ultrasonic blade control algorithm(s) 802. In another aspect, the device/instrument 235 is configured to execute the adaptive ultrasonic blade control algorithm(s) 804. In another aspect, both the generator module 240 and the device/instrument 235 are configured to execute the adaptive ultrasonic blade control algorithms 802, 804.

[0206] The generator module 240 may comprise a patient isolated stage in communication with a non-isolated stage via a power transformer. A secondary winding of the power transformer is contained in the isolated stage and may comprise a tapped configuration (e.g., a center-tapped or a non-center-tapped configuration) to define drive signal outputs for delivering drive signals to different surgical instruments, such as, for example, an ultrasonic surgical instrument, an RF electro-surgical instrument, and a multifunction surgical instrument which includes ultrasonic and RF energy modes that can be delivered alone or simultaneously. In particular, the drive signal outputs may output an ultrasonic drive signal (e.g., a 420V root-mean-square (RMS) drive signal) to an ultrasonic surgical instrument 241, and the drive signal outputs may output an RF electro-surgical drive signal (e.g., a 100V RMS drive signal) to an RF electro-surgical instrument 241. Aspects of the generator module 240 are described herein with reference to FIGS. 21–22.

[0207] The generator module 240 or the device/instrument 235 or both are coupled the modular control tower 236 connected to multiple operating theater devices such as, for example, intelligent surgical instruments, robots, and other computerized devices located in the operating theater, as described with reference to FIGS. 8–11, for example.

[0208] FIG. 21 illustrates an example of a generator 900, which is one form of a generator configured to couple to an ultrasonic instrument and further configured to execute adaptive ultrasonic blade control algorithms in a surgical data network comprising a modular communication hub as shown in FIG. 20. The generator 900 is configured to deliver multiple energy modalities to a surgical instrument. The generator 900 provides RF and ultrasonic signals for delivering energy to a surgical instrument either independently or simultaneously. The RF and ultrasonic signals may be provided alone or in combination and may be provided simultaneously. As noted above, at least one generator output can deliver multiple energy modalities (e.g., ultrasonic, bipolar or monopolar RF, irreversible and/or reversible electroporation, and/or microwave energy, among others) through a single port, and these signals can be delivered separately or simultaneously to the end effector to treat tissue. The

generator 900 comprises a processor 902 coupled to a waveform generator 904. The processor 902 and waveform generator 904 are configured to generate a variety of signal waveforms based on information stored in a memory coupled to the processor 902, not shown for clarity of disclosure. The digital information associated with a waveform is provided to the waveform generator 904 which includes one or more DAC circuits to convert the digital input into an analog output. The analog output is fed to an amplifier 1106 for signal conditioning and amplification. The conditioned and amplified output of the amplifier 906 is coupled to a power transformer 908. The signals are coupled across the power transformer 908 to the secondary side, which is in the patient isolation side. A first signal of a first energy modality is provided to the surgical instrument between the terminals labeled ENERGY₁ and RETURN. A second signal of a second energy modality is coupled across a capacitor 910 and is provided to the surgical instrument between the terminals labeled ENERGY₂ and RETURN. It will be appreciated that more than two energy modalities may be output and thus the subscript "n" may be used to designate that up to n ENERGY_n terminals may be provided, where n is a positive integer greater than 1. It also will be appreciated that up to "n" return paths RETURN_n may be provided without departing from the scope of the present disclosure.

[0209] A first voltage sensing circuit 912 is coupled across the terminals labeled ENERGY₁ and the RETURN path to measure the output voltage therebetween. A second voltage sensing circuit 924 is coupled across the terminals labeled ENERGY₂ and the RETURN path to measure the output voltage therebetween. A current sensing circuit 914 is disposed in series with the RETURN leg of the secondary side of the power transformer 908 as shown to measure the output current for either energy modality. If different return paths are provided for each energy modality, then a separate current sensing circuit should be provided in each return leg. The outputs of the first and second voltage sensing circuits 912, 924 are provided to respective isolation transformers 916, 922 and the output of the current sensing circuit 914 is provided to another isolation transformer 918. The outputs of the isolation transformers 916, 928, 922 in the on the primary side of the power transformer 908 (non-patient isolated side) are provided to a one or more ADC circuit 926. The digitized output of the ADC circuit 926 is provided to the processor 902 for further processing and computation. The output voltages and output current feedback information can be employed to adjust the output voltage and current provided to the surgical instrument and to compute output impedance, among other parameters. Input/output communications between the processor 902 and patient isolated circuits is provided through an interface circuit 920. Sensors also may be in electrical communication with the processor 902 by way of the interface circuit 920.

[0210] In one aspect, the impedance may be determined by the processor 902 by dividing the output of either the first voltage sensing circuit 912 coupled across the terminals labeled ENERGY₁/RETURN or the second voltage sensing circuit 924 coupled across the terminals labeled ENERGY₂/RETURN by the output of the current sensing circuit 914 disposed in series with the RETURN leg of the secondary side of the power transformer 908. The outputs of the first and second voltage sensing circuits 912, 924 are provided to separate isolations transformers 916, 922 and the output of the current sensing circuit 914 is provided to another isolation transformer 916. The digitized voltage and current sensing measurements from the ADC circuit 926 are provided the processor 902 for computing impedance. As an example, the first energy modality ENERGY₁ may be ultrasonic energy and the second energy modality ENERGY₂ may be RF energy. Nevertheless, in addition to ultrasonic and bipolar or monopolar RF energy modalities, other energy modalities include irreversible and/or reversible electroporation and/or microwave energy, among others. Also, although the example illustrated in FIG. 21 shows a single return path RETURN may be provided for two or more energy modalities, in other aspects, multiple return paths RETURN_n may be provided for each energy modality ENERGY_n. Thus, as described herein, the ultrasonic transducer impedance may be measured by dividing the output of the first voltage sensing circuit 912 by the current sensing circuit 914 and the tissue impedance may be measured by dividing the output of the second voltage sensing circuit 924 by the current sensing circuit 914.

[0211] As shown in FIG. 21, the generator 900 comprising at least one output port can include a power transformer 908 with a single output and with multiple taps to provide power in the form of one or more energy modalities, such as ultrasonic, bipolar or monopolar RF, irreversible and/or reversible electroporation, and/or microwave energy, among others, for example, to the end effector depending on the type of treatment of tissue being performed. For example, the generator 900 can deliver energy with higher voltage and lower current to drive an ultrasonic transducer, with lower voltage and higher current to drive RF electrodes for sealing tissue, or with a coagulation waveform for spot coagulation using either monopolar or bipolar RF electrosurgical electrodes. The output waveform from the generator 900 can be steered, switched, or filtered to provide the frequency to the end effector of the surgical instrument. The connection of an ultrasonic transducer to the generator 900 output would be preferably located between the output labeled ENERGY₁ and RETURN as shown in FIG. 21. In one example, a connection of RF bipolar electrodes to the generator 900 output would be preferably located between the output labeled ENERGY₂ and RETURN. In the case of monopolar output, the preferred connections would be active electrode (e.g., pencil or other probe) to the ENERGY₂ output and a suitable return pad connected to the RETURN output.

[0212] Additional details are disclosed in U.S. Patent Application Publication No. 2017/0086914, titled TECHNIQUES FOR OPERATING GENERATOR FOR DIGITALLY GENERATING ELECTRICAL SIGNAL WAVEFORMS AND SURGICAL INSTRUMENTS, which published on March 30, 2017, which is herein incorporated by reference in its entirety.

[0213] As used throughout this description, the term “wireless” and its derivatives may be used to describe circuits, devices, systems, methods, techniques, communications channels, etc., that may communicate data through the use of modulated electromagnetic radiation through a non-solid medium. The term does not imply that the associated devices do not contain any wires, although in some aspects they might not. The communication module may implement any of a number of wireless or wired communication standards or protocols, including but not limited to Wi-Fi (IEEE 802.11 family), WiMAX (IEEE 802.16 family), IEEE 802.20, long term evolution (LTE), Ev-DO, HSPA+, HSDPA+, HSUPA+, EDGE, GSM, GPRS, CDMA, TDMA, DECT, Bluetooth, Ethernet derivatives thereof, as well as any other wireless and wired protocols that are designated as 3G, 4G, 5G, and beyond. The computing module may include a plurality of communication modules. For instance, a first communication module may be dedicated to shorter range wireless communications such as Wi-Fi and Bluetooth and a second communication module may be dedicated to longer range wireless communications such as GPS, EDGE, GPRS, CDMA, WiMAX, LTE, Ev-DO, and others.

[0214] As used herein a processor or processing unit is an electronic circuit which performs operations on some external data source, usually memory or some other data stream. The term is used herein to refer to the central processor (central processing unit) in a system or computer systems (especially systems on a chip (SoCs)) that combine a number of specialized “processors.”

[0215] As used herein, a system on a chip or system on chip (SoC or SOC) is an integrated circuit (also known as an “IC” or “chip”) that integrates all components of a computer or other electronic systems. It may contain digital, analog, mixed-signal, and often radio-frequency functions—all on a single substrate. A SoC integrates a microcontroller (or microprocessor) with advanced peripherals like graphics processing unit (GPU), Wi-Fi module, or coprocessor. A SoC may or may not contain built-in memory.

[0216] As used herein, a microcontroller or controller is a system that integrates a microprocessor with peripheral circuits and memory. A microcontroller (or MCU for microcontroller unit) may be implemented as a small computer on a single integrated circuit. It may be similar to a SoC; a SoC may include a microcontroller as one of its components. A microcontroller may contain one or more core processing units (CPUs) along with memory and programmable input/output peripherals. Program memory in the form of Ferroelectric RAM, NOR flash or OTP ROM is also often included on chip, as well as a small amount of

RAM. Microcontrollers may be employed for embedded applications, in contrast to the microprocessors used in personal computers or other general purpose applications consisting of various discrete chips.

[0217] As used herein, the term controller or microcontroller may be a stand-alone IC or chip device that interfaces with a peripheral device. This may be a link between two parts of a computer or a controller on an external device that manages the operation of (and connection with) that device.

[0218] Any of the processors or microcontrollers described herein, may be implemented by any single core or multicore processor such as those known under the trade name ARM Cortex by Texas Instruments. In one aspect, the processor may be an LM4F230H5QR ARM Cortex-M4F Processor Core, available from Texas Instruments, for example, comprising on-chip memory of 256 KB single-cycle flash memory, or other non-volatile memory, up to 40 MHz, a prefetch buffer to improve performance above 40 MHz, a 32 KB single-cycle serial random access memory (SRAM), internal read-only memory (ROM) loaded with StellarisWare® software, 2 KB electrically erasable programmable read-only memory (EEPROM), one or more pulse width modulation (PWM) modules, one or more quadrature encoder inputs (QEI) analog, one or more 12-bit Analog-to-Digital Converters (ADC) with 12 analog input channels, details of which are available for the product datasheet.

[0219] In one aspect, the processor may comprise a safety controller comprising two controller-based families such as TMS570 and RM4x known under the trade name Hercules ARM Cortex R4, also by Texas Instruments. The safety controller may be configured specifically for IEC 61508 and ISO 26262 safety critical applications, among others, to provide advanced integrated safety features while delivering scalable performance, connectivity, and memory options.

[0220] Modular devices include the modules (as described in connection with FIGS. 3 and 9, for example) that are receivable within a surgical hub and the surgical devices or instruments that can be connected to the various modules in order to connect or pair with the corresponding surgical hub. The modular devices include, for example, intelligent surgical instruments, medical imaging devices, suction/irrigation devices, smoke evacuators, energy generators, ventilators, insufflators, and displays. The modular devices described herein can be controlled by control algorithms. The control algorithms can be executed on the modular device itself, on the surgical hub to which the particular modular device is paired, or on both the modular device and the surgical hub (e.g., via a distributed computing architecture). In some exemplifications, the modular devices' control algorithms control the devices based on data sensed by the modular device itself (i.e., by sensors in, on, or connected to the modular device). This data can be related to the patient being operated on (e.g., tissue properties or insufflation pressure) or the modular device itself (e.g., the rate at which a knife is being

advanced, motor current, or energy levels). For example, a control algorithm for a surgical stapling and cutting instrument can control the rate at which the instrument's motor drives its knife through tissue according to resistance encountered by the knife as it advances.

[0221] FIG. 22 illustrates one form of a surgical system 1000 comprising a generator 1100 and various surgical instruments 1104, 1106, 1108 usable therewith, where the surgical instrument 1104 is an ultrasonic surgical instrument, the surgical instrument 1106 is an RF electro-surgical instrument, and the multifunction surgical instrument 1108 is a combination ultrasonic/RF electro-surgical instrument. The generator 1100 is configurable for use with a variety of surgical instruments. According to various forms, the generator 1100 may be configurable for use with different surgical instruments of different types including, for example, ultrasonic surgical instruments 1104, RF electro-surgical instruments 1106, and multifunction surgical instruments 1108 that integrate RF and ultrasonic energies delivered simultaneously from the generator 1100. Although in the form of FIG. 22 the generator 1100 is shown separate from the surgical instruments 1104, 1106, 1108 in one form, the generator 1100 may be formed integrally with any of the surgical instruments 1104, 1106, 1108 to form a unitary surgical system. The generator 1100 comprises an input device 1110 located on a front panel of the generator 1100 console. The input device 1110 may comprise any suitable device that generates signals suitable for programming the operation of the generator 1100. The generator 1100 may be configured for wired or wireless communication.

[0222] The generator 1100 is configured to drive multiple surgical instruments 1104, 1106, 1108. The first surgical instrument is an ultrasonic surgical instrument 1104 and comprises a handpiece 1105 (HP), an ultrasonic transducer 1120, a shaft 1126, and an end effector 1122. The end effector 1122 comprises an ultrasonic blade 1128 acoustically coupled to the ultrasonic transducer 1120 and a clamp arm 1140. The handpiece 1105 comprises a trigger 1143 to operate the clamp arm 1140 and a combination of the toggle buttons 1134a, 1134b, 1134c to energize and drive the ultrasonic blade 1128 or other function. The toggle buttons 1134a, 1134b, 1134c can be configured to energize the ultrasonic transducer 1120 with the generator 1100.

[0223] The generator 1100 also is configured to drive a second surgical instrument 1106. The second surgical instrument 1106 is an RF electro-surgical instrument and comprises a handpiece 1107 (HP), a shaft 1127, and an end effector 1124. The end effector 1124 comprises electrodes in clamp arms 1142a, 1142b and return through an electrical conductor portion of the shaft 1127. The electrodes are coupled to and energized by a bipolar energy source within the generator 1100. The handpiece 1107 comprises a trigger 1145 to operate the clamp arms 1142a, 1142b and an energy button 1135 to actuate an energy switch to energize the electrodes in the end effector 1124.

[0224] The generator 1100 also is configured to drive a multifunction surgical instrument 1108. The multifunction surgical instrument 1108 comprises a handpiece 1109 (HP), a shaft 1129, and an end effector 1125. The end effector 1125 comprises an ultrasonic blade 1149 and a clamp arm 1146. The ultrasonic blade 1149 is acoustically coupled to the ultrasonic transducer 1120. The handpiece 1109 comprises a trigger 1147 to operate the clamp arm 1146 and a combination of the toggle buttons 1137a, 1137b, 1137c to energize and drive the ultrasonic blade 1149 or other function. The toggle buttons 1137a, 1137b, 1137c can be configured to energize the ultrasonic transducer 1120 with the generator 1100 and energize the ultrasonic blade 1149 with a bipolar energy source also contained within the generator 1100.

[0225] The generator 1100 is configurable for use with a variety of surgical instruments. According to various forms, the generator 1100 may be configurable for use with different surgical instruments of different types including, for example, the ultrasonic surgical instrument 1104, the RF electrosurgical instrument 1106, and the multifunction surgical instrument 1108 that integrates RF and ultrasonic energies delivered simultaneously from the generator 1100. Although in the form of FIG. 22 the generator 1100 is shown separate from the surgical instruments 1104, 1106, 1108, in another form the generator 1100 may be formed integrally with any one of the surgical instruments 1104, 1106, 1108 to form a unitary surgical system. As discussed above, the generator 1100 comprises an input device 1110 located on a front panel of the generator 1100 console. The input device 1110 may comprise any suitable device that generates signals suitable for programming the operation of the generator 1100. The generator 1100 also may comprise one or more output devices 1112. Further aspects of generators for digitally generating electrical signal waveforms and surgical instruments are described in US patent publication US-2017-0086914-A1, which is herein incorporated by reference in its entirety.

Situational Awareness

[0226] Although an “intelligent” device including control algorithms that respond to sensed data can be an improvement over a “dumb” device that operates without accounting for sensed data, some sensed data can be incomplete or inconclusive when considered in isolation, i.e., without the context of the type of surgical procedure being performed or the type of tissue that is being operated on. Without knowing the procedural context (e.g., knowing the type of tissue being operated on or the type of procedure being performed), the control algorithm may control the modular device incorrectly or suboptimally given the particular context-free sensed data. For example, the optimal manner for a control algorithm to control a surgical instrument in response to a particular sensed parameter can vary

according to the particular tissue type being operated on. This is due to the fact that different tissue types have different properties (e.g., resistance to tearing) and thus respond differently to actions taken by surgical instruments. Therefore, it may be desirable for a surgical instrument to take different actions even when the same measurement for a particular parameter is sensed. As one specific example, the optimal manner in which to control a surgical stapling and cutting instrument in response to the instrument sensing an unexpectedly high force to close its end effector will vary depending upon whether the tissue type is susceptible or resistant to tearing. For tissues that are susceptible to tearing, such as lung tissue, the instrument's control algorithm would optimally ramp down the motor in response to an unexpectedly high force to close to avoid tearing the tissue. For tissues that are resistant to tearing, such as stomach tissue, the instrument's control algorithm would optimally ramp up the motor in response to an unexpectedly high force to close to ensure that the end effector is clamped properly on the tissue. Without knowing whether lung or stomach tissue has been clamped, the control algorithm may make a suboptimal decision.

[0227] One solution utilizes a surgical hub including a system that is configured to derive information about the surgical procedure being performed based on data received from various data sources and then control the paired modular devices accordingly. In other words, the surgical hub is configured to infer information about the surgical procedure from received data and then control the modular devices paired to the surgical hub based upon the inferred context of the surgical procedure. FIG. 23 illustrates a diagram of a situationally aware surgical system 5100, in accordance with at least one aspect of the present disclosure. In some exemplifications, the data sources 5126 include, for example, the modular devices 5102 (which can include sensors configured to detect parameters associated with the patient and/or the modular device itself), databases 5122 (e.g., an EMR database containing patient records), and patient monitoring devices 5124 (e.g., a blood pressure (BP) monitor and an electrocardiography (EKG) monitor). The surgical hub 5104 can be configured to derive the contextual information pertaining to the surgical procedure from the data based upon, for example, the particular combination(s) of received data or the particular order in which the data is received from the data sources 5126. The contextual information inferred from the received data can include, for example, the type of surgical procedure being performed, the particular step of the surgical procedure that the surgeon is performing, the type of tissue being operated on, or the body cavity that is the subject of the procedure. This ability by some aspects of the surgical hub 5104 to derive or infer information related to the surgical procedure from received data can be referred to as "situational awareness." In one exemplification, the surgical hub 5104 can incorporate a situational awareness system, which is the hardware and/or programming associated with

the surgical hub 5104 that derives contextual information pertaining to the surgical procedure from the received data.

[0228] The situational awareness system of the surgical hub 5104 can be configured to derive the contextual information from the data received from the data sources 5126 in a variety of different ways. In one exemplification, the situational awareness system includes a pattern recognition system, or machine learning system (e.g., an artificial neural network), that has been trained on training data to correlate various inputs (e.g., data from databases 5122, patient monitoring devices 5124, and/or modular devices 5102) to corresponding contextual information regarding a surgical procedure. In other words, a machine learning system can be trained to accurately derive contextual information regarding a surgical procedure from the provided inputs. In another exemplification, the situational awareness system can include a lookup table storing pre-characterized contextual information regarding a surgical procedure in association with one or more inputs (or ranges of inputs) corresponding to the contextual information. In response to a query with one or more inputs, the lookup table can return the corresponding contextual information for the situational awareness system for controlling the modular devices 5102. In one exemplification, the contextual information received by the situational awareness system of the surgical hub 5104 is associated with a particular control adjustment or set of control adjustments for one or more modular devices 5102. In another exemplification, the situational awareness system includes a further machine learning system, lookup table, or other such system, which generates or retrieves one or more control adjustments for one or more modular devices 5102 when provided the contextual information as input.

[0229] A surgical hub 5104 incorporating a situational awareness system provides a number of benefits for the surgical system 5100. One benefit includes improving the interpretation of sensed and collected data, which would in turn improve the processing accuracy and/or the usage of the data during the course of a surgical procedure. To return to a previous example, a situationally aware surgical hub 5104 could determine what type of tissue was being operated on; therefore, when an unexpectedly high force to close the surgical instrument's end effector is detected, the situationally aware surgical hub 5104 could correctly ramp up or ramp down the motor of the surgical instrument for the type of tissue.

[0230] As another example, the type of tissue being operated can affect the adjustments that are made to the compression rate and load thresholds of a surgical stapling and cutting instrument for a particular tissue gap measurement. A situationally aware surgical hub 5104 could infer whether a surgical procedure being performed is a thoracic or an abdominal procedure, allowing the surgical hub 5104 to determine whether the tissue clamped by an end effector of the surgical stapling and cutting instrument is lung (for a thoracic procedure)

or stomach (for an abdominal procedure) tissue. The surgical hub 5104 could then adjust the compression rate and load thresholds of the surgical stapling and cutting instrument appropriately for the type of tissue.

[0231] As yet another example, the type of body cavity being operated in during an insufflation procedure can affect the function of a smoke evacuator. A situationally aware surgical hub 5104 could determine whether the surgical site is under pressure (by determining that the surgical procedure is utilizing insufflation) and determine the procedure type. As a procedure type is generally performed in a specific body cavity, the surgical hub 5104 could then control the motor rate of the smoke evacuator appropriately for the body cavity being operated in. Thus, a situationally aware surgical hub 5104 could provide a consistent amount of smoke evacuation for both thoracic and abdominal procedures.

[0232] As yet another example, the type of procedure being performed can affect the optimal energy level for an ultrasonic surgical instrument or radio frequency (RF) electro-surgical instrument to operate at. Arthroscopic procedures, for example, require higher energy levels because the end effector of the ultrasonic surgical instrument or RF electro-surgical instrument is immersed in fluid. A situationally aware surgical hub 5104 could determine whether the surgical procedure is an arthroscopic procedure. The surgical hub 5104 could then adjust the RF power level or the ultrasonic amplitude of the generator (i.e., "energy level") to compensate for the fluid filled environment. Relatedly, the type of tissue being operated on can affect the optimal energy level for an ultrasonic surgical instrument or RF electro-surgical instrument to operate at. A situationally aware surgical hub 5104 could determine what type of surgical procedure is being performed and then customize the energy level for the ultrasonic surgical instrument or RF electro-surgical instrument, respectively, according to the expected tissue profile for the surgical procedure.

Furthermore, a situationally aware surgical hub 5104 can be configured to adjust the energy level for the ultrasonic surgical instrument or RF electro-surgical instrument throughout the course of a surgical procedure, rather than just on a procedure-by-procedure basis. A situationally aware surgical hub 5104 could determine what step of the surgical procedure is being performed or will subsequently be performed and then update the control algorithms for the generator and/or ultrasonic surgical instrument or RF electro-surgical instrument to set the energy level at a value appropriate for the expected tissue type according to the surgical procedure step.

[0233] As yet another example, data can be drawn from additional data sources 5126 to improve the conclusions that the surgical hub 5104 draws from one data source 5126. A situationally aware surgical hub 5104 could augment data that it receives from the modular devices 5102 with contextual information that it has built up regarding the surgical procedure from other data sources 5126. For example, a situationally aware surgical hub 5104 can be

configured to determine whether hemostasis has occurred (i.e., whether bleeding at a surgical site has stopped) according to video or image data received from a medical imaging device. However, in some cases the video or image data can be inconclusive. Therefore, in one exemplification, the surgical hub 5104 can be further configured to compare a physiologic measurement (e.g., blood pressure sensed by a BP monitor communicably connected to the surgical hub 5104) with the visual or image data of hemostasis (e.g., from a medical imaging device 124 (FIG. 2) communicably coupled to the surgical hub 5104) to make a determination on the integrity of the staple line or tissue weld. In other words, the situational awareness system of the surgical hub 5104 can consider the physiological measurement data to provide additional context in analyzing the visualization data. The additional context can be useful when the visualization data may be inconclusive or incomplete on its own.

[0234] Another benefit includes proactively and automatically controlling the paired modular devices 5102 according to the particular step of the surgical procedure that is being performed to reduce the number of times that medical personnel are required to interact with or control the surgical system 5100 during the course of a surgical procedure. For example, a situationally aware surgical hub 5104 could proactively activate the generator to which an RF electrosurgical instrument is connected if it determines that a subsequent step of the procedure requires the use of the instrument. Proactively activating the energy source allows the instrument to be ready for use as soon as the preceding step of the procedure is completed.

[0235] As another example, a situationally aware surgical hub 5104 could determine whether the current or subsequent step of the surgical procedure requires a different view or degree of magnification on the display according to the feature(s) at the surgical site that the surgeon is expected to need to view. The surgical hub 5104 could then proactively change the displayed view (supplied by, e.g., a medical imaging device for the visualization system 108) accordingly so that the display automatically adjusts throughout the surgical procedure.

[0236] As yet another example, a situationally aware surgical hub 5104 could determine which step of the surgical procedure is being performed or will subsequently be performed and whether particular data or comparisons between data will be required for that step of the surgical procedure. The surgical hub 5104 can be configured to automatically call up data screens based upon the step of the surgical procedure being performed, without waiting for the surgeon to ask for the particular information.

[0237] Another benefit includes checking for errors during the setup of the surgical procedure or during the course of the surgical procedure. For example, a situationally aware surgical hub 5104 could determine whether the operating theater is setup properly or optimally for the surgical procedure to be performed. The surgical hub 5104 can be

configured to determine the type of surgical procedure being performed, retrieve the corresponding checklists, product location, or setup needs (e.g., from a memory), and then compare the current operating theater layout to the standard layout for the type of surgical procedure that the surgical hub 5104 determines is being performed. In one exemplification, the surgical hub 5104 can be configured to compare the list of items for the procedure (scanned by a scanner, for example) and/or a list of devices paired with the surgical hub 5104 to a recommended or anticipated manifest of items and/or devices for the given surgical procedure. If there are any discontinuities between the lists, the surgical hub 5104 can be configured to provide an alert indicating that a particular modular device 5102, patient monitoring device 5124, and/or other surgical item is missing. In one exemplification, the surgical hub 5104 can be configured to determine the relative distance or position of the modular devices 5102 and patient monitoring devices 5124 via proximity sensors, for example. The surgical hub 5104 can compare the relative positions of the devices to a recommended or anticipated layout for the particular surgical procedure. If there are any discontinuities between the layouts, the surgical hub 5104 can be configured to provide an alert indicating that the current layout for the surgical procedure deviates from the recommended layout.

[0238] As another example, a situationally aware surgical hub 5104 could determine whether the surgeon (or other medical personnel) was making an error or otherwise deviating from the expected course of action during the course of a surgical procedure. For example, the surgical hub 5104 can be configured to determine the type of surgical procedure being performed, retrieve the corresponding list of steps or order of equipment usage (e.g., from a memory), and then compare the steps being performed or the equipment being used during the course of the surgical procedure to the expected steps or equipment for the type of surgical procedure that the surgical hub 5104 determined is being performed. In one exemplification, the surgical hub 5104 can be configured to provide an alert indicating that an unexpected action is being performed or an unexpected device is being utilized at the particular step in the surgical procedure.

[0239] Overall, the situational awareness system for the surgical hub 5104 improves surgical procedure outcomes by adjusting the surgical instruments (and other modular devices 5102) for the particular context of each surgical procedure (such as adjusting to different tissue types) and validating actions during a surgical procedure. The situational awareness system also improves surgeons' efficiency in performing surgical procedures by automatically suggesting next steps, providing data, and adjusting displays and other modular devices 5102 in the surgical theater according to the specific context of the procedure.

Modular Energy System

[0240] ORs everywhere in the world are a tangled web of cords, devices, and people due to the amount of equipment required to perform surgical procedures. Surgical capital equipment tends to be a major contributor to this issue because most surgical capital equipment performs a single, specialized task. Due to their specialized nature and the surgeons' needs to utilize multiple different types of devices during the course of a single surgical procedure, an OR may be forced to be stocked with two or even more pieces of surgical capital equipment, such as energy generators. Each of these pieces of surgical capital equipment must be individually plugged into a power source and may be connected to one or more other devices that are being passed between OR personnel, creating a tangle of cords that must be navigated. Another issue faced in modern ORs is that each of these specialized pieces of surgical capital equipment has its own user interface and must be independently controlled from the other pieces of equipment within the OR. This creates complexity in properly controlling multiple different devices in connection with each other and forces users to be trained on and memorize different types of user interfaces (which may further change based upon the task or surgical procedure being performed, in addition to changing between each piece of capital equipment). This cumbersome, complex process can necessitate the need for even more individuals to be present within the OR and can create danger if multiple devices are not properly controlled in tandem with each other. Therefore, consolidating surgical capital equipment technology into singular systems that are able to flexibly address surgeons' needs to reduce the footprint of surgical capital equipment within ORs would simplify the user experience, reduce the amount of clutter in ORs, and prevent difficulties and dangers associated with simultaneously controlling multiple pieces of capital equipment. Further, making such systems expandable or customizable would allow for new technology to be conveniently incorporated into existing surgical systems, obviating the need to replace entire surgical systems or for OR personnel to learn new user interfaces or equipment controls with each new technology.

[0241] As described in FIGS. 1–11, a surgical hub 106 can be configured to interchangeably receive a variety of modules, which can in turn interface with surgical devices (e.g., a surgical instrument or a smoke evacuator) or provide various other functions (e.g., communications). In one aspect, a surgical hub 106 can be embodied as a modular energy system 2000, which is illustrated in connection with FIGS. 24–30. The modular energy system 2000 can include a variety of different modules 2001 that are connectable together in a stacked configuration. In one aspect, the modules 2001 can be both physically and communicably coupled together when stacked or otherwise connected together into a singular assembly. Further, the modules 2001 can be interchangeably connectable together

in different combinations or arrangements. In one aspect, each of the modules 2001 can include a consistent or universal array of connectors disposed along their upper and lower surfaces, thereby allowing any module 2001 to be connected to another module 2001 in any arrangement (except that, in some aspects, a particular module type, such as the header module 2002, can be configured to serve as the uppermost module within the stack, for example). In an alternative aspect, the modular energy system 2000 can include a housing that is configured to receive and retain the modules 2001, as is shown in FIGS. 3 and 4. The modular energy system 2000 can also include a variety of different components or accessories that are also connectable to or otherwise associatable with the modules 2001. In another aspect, the modular energy system 2000 can be embodied as a generator module 140, 240 (FIGS. 3 and 10) of a surgical hub 106. In yet another aspect, the modular energy system 2000 can be a distinct system from a surgical hub 106. In such aspects, the modular energy system 2000 can be communicably couplable to a surgical hub 206 for transmitting and/or receiving data therebetween.

[0242] The modular energy system 2000 can be assembled from a variety of different modules 2001, some examples of which are illustrated in FIG. 24. Each of the different types of modules 2001 can provide different functionality, thereby allowing the modular energy system 2000 to be assembled into different configurations to customize the functions and capabilities of the modular energy system 2000 by customizing the modules 2001 that are included in each modular energy system 2000. The modules 2001 of the modular energy system 2000 can include, for example, a header module 2002 (which can include a display screen 2006), an energy module 2004, a technology module 2040, and a visualization module 2042. In the depicted aspect, the header module 2002 is configured to serve as the top or uppermost module within the modular energy system stack and can thus lack connectors along its top surface. In another aspect, the header module 2002 can be configured to be positioned at the bottom or the lowermost module within the modular energy system stack and can thus lack connectors along its bottom surface. In yet another aspect, the header module 2002 can be configured to be positioned at an intermediate position within the modular energy system stack and can thus include connectors along both its bottom and top surfaces. The header module 2002 can be configured to control the system-wide settings of each module 2001 and component connected thereto through physical controls 2011 thereon and/or a graphical user interface (GUI) 2008 rendered on the display screen 2006. Such settings could include the activation of the modular energy system 2000, the volume of alerts, the footswitch settings, the settings icons, the appearance or configuration of the user interface, the surgeon profile logged into the modular energy system 2000, and/or the type of surgical procedure being performed. The header module 2002 can also be configured to provide communications, processing, and/or

power for the modules 2001 that are connected to the header module 2002. The energy module 2004, which can also be referred to as a generator module 140, 240 (FIGS. 3 and 10), can be configured to generate one or multiple energy modalities for driving electrosurgical and/or ultrasonic surgical instruments connected thereto, such as is described above in connection with the generator 900 illustrated in FIG. 21. The technology module 2040 can be configured to provide additional or expanded control algorithms (e.g., electrosurgical or ultrasonic control algorithms for controlling the energy output of the energy module 2004). The visualization module 2042 can be configured to interface with visualization devices (i.e., scopes) and accordingly provide increased visualization capabilities.

[0243] The modular energy system 2000 can further include a variety of accessories 2029 that are connectable to the modules 2001 for controlling the functions thereof or that are otherwise configured to work on conjunction with the modular energy system 2000. The accessories 2029 can include, for example, a single-pedal footswitch 2032, a dual-pedal footswitch 2034, and a cart 2030 for supporting the modular energy system 2000 thereon. The footswitches 2032, 2034 can be configured to control the activation or function of particular energy modalities output by the energy module 2004, for example.

[0244] By utilizing modular components, the depicted modular energy system 2000 provides a surgical platform that grows with the availability of technology and is customizable to the needs of the facility and/or surgeons. Further, the modular energy system 2000 supports combo devices (e.g., dual electrosurgical and ultrasonic energy generators) and supports software-driven algorithms for customized tissue effects. Still further, the surgical system architecture reduces the capital footprint by combining multiple technologies critical for surgery into a single system.

[0245] The various modular components utilizable in connection with the modular energy system 2000 can include monopolar energy generators, bipolar energy generators, dual electrosurgical/ultrasonic energy generators, display screens, and various other modules and/or other components, some of which are also described above in connection with FIGS. 1–11.

[0246] Referring now to FIG. 25A, the header module 2002 can, in some aspects, include a display screen 2006 that renders a GUI 2008 for relaying information regarding the modules 2001 connected to the header module 2002. In some aspects, the GUI 2008 of the display screen 2006 can provide a consolidated point of control of all of the modules 2001 making up the particular configuration of the modular energy system 2000. Various aspects of the GUI 2008 are discussed in fuller detail below in connection with FIG. 30. In alternative aspects, the header module 2002 can lack the display screen 2006 or the display screen 2006 can be detachably connected to the housing 2010 of the header module 2002. In such

aspects, the header module 2002 can be communicably couplable to an external system that is configured to display the information generated by the modules 2001 of the modular energy system 2000. For example, in robotic surgical applications, the modular energy system 2000 can be communicably couplable to a robotic cart or robotic control console, which is configured to display the information generated by the modular energy system 2000 to the operator of the robotic surgical system. As another example, the modular energy system 2000 can be communicably couplable to a mobile display that can be carried or secured to a surgical staff member for viewing thereby. In yet another example, the modular energy system 2000 can be communicably couplable to a surgical hub 2100 or another computer system that can include a display 2104, as is illustrated in FIG. 29. In aspects utilizing a user interface that is separate from or otherwise distinct from the modular energy system 2000, the user interface can be wirelessly connectable with the modular energy system 2000 as a whole or one or more modules 2001 thereof such that the user interface can display information from the connected modules 2001 thereon.

[0247] Referring still to FIG. 25A, the energy module 2004 can include a port assembly 2012 including a number of different ports configured to deliver different energy modalities to corresponding surgical instruments that are connectable thereto. In the particular aspect illustrated in FIGS. 24–30, the port assembly 2012 includes a bipolar port 2014, a first monopolar port 2016a, a second monopolar port 2018b, a neutral electrode port 2018 (to which a monopolar return pad is connectable), and a combination energy port 2020. However, this particular combination of ports is simply provided for illustrative purposes and alternative combinations of ports and/or energy modalities may be possible for the port assembly 2012.

[0248] As noted above, the modular energy system 2000 can be assembled into different configurations. Further, the different configurations of the modular energy system 2000 can also be utilizable for different surgical procedure types and/or different tasks. For example, FIGS. 25A and 25B illustrate a first illustrative configuration of the modular energy system 2000 including a header module 2002 (including a display screen 2006) and an energy module 2004 connected together. Such a configuration can be suitable for laparoscopic and open surgical procedures, for example.

[0249] FIG. 26A illustrates a second illustrative configuration of the modular energy system 2000 including a header module 2002 (including a display screen 2006), a first energy module 2004a, and a second energy module 2004b connected together. By stacking two energy modules 2004a, 2004b, the modular energy system 2000 can provide a pair of port assemblies 2012a, 2012b for expanding the array of energy modalities deliverable by the modular energy system 2000 from the first configuration. The second configuration of the modular energy system 2000 can accordingly accommodate more than one

bipolar/monopolar electrosurgical instrument, more than two bipolar/monopolar electrosurgical instruments, and so on. Such a configuration can be suitable for particularly complex laparoscopic and open surgical procedures. FIG. 26B illustrates a third illustrative configuration that is similar to the second configuration, except that the header module 2002 lacks a display screen 2006. This configuration can be suitable for robotic surgical applications or mobile display applications, as noted above.

[0250] FIG. 27 illustrates a fourth illustrative configuration of the modular energy system 2000 including a header module 2002 (including a display screen 2006), a first energy module 2004a, a second energy module 2004b, and a technology module 2040 connected together. Such a configuration can be suitable for surgical applications where particularly complex or computation-intensive control algorithms are required. Alternatively, the technology module 2040 can be a newly released module that supplements or expands the capabilities of previously released modules (such as the energy module 2004).

[0251] FIG. 28 illustrates a fifth illustrative configuration of the modular energy system 2000 including a header module 2002 (including a display screen 2006), a first energy module 2004a, a second energy module 2004b, a technology module 2040, and a visualization module 2042 connected together. Such a configuration can be suitable for endoscopic procedures by providing a dedicated surgical display 2044 for relaying the video feed from the scope coupled to the visualization module 2042. It should be noted that the configurations illustrated in FIGS. 25A–29 and described above are provided simply to illustrate the various concepts of the modular energy system 2000 and should not be interpreted to limit the modular energy system 2000 to the particular aforementioned configurations.

[0252] As noted above, the modular energy system 2000 can be communicably couplable to an external system, such as a surgical hub 2100 as illustrated in FIG. 29. Such external systems can include a display screen 2104 for displaying a visual feed from an endoscope (or a camera or another such visualization device) and/or data from the modular energy system 2000. Such external systems can also include a computer system 2102 for performing calculations or otherwise analyzing data generated or provided by the modular energy system 2000, controlling the functions or modes of the modular energy system 2000, and/or relaying data to a cloud computing system or another computer system. Such external systems could also coordinate actions between multiple modular energy systems 2000 and/or other surgical systems (e.g., a visualization system 108 and/or a robotic system 110 as described in connection with FIGS. 1 and 2).

[0253] Referring now to FIG. 30, in some aspects, the header module 2002 can include or support a display 2006 configured for displaying a GUI 2008, as noted above. The display screen 2006 can include a touchscreen for receiving input from users in addition to

displaying information. The controls displayed on the GUI 2008 can correspond to the module(s) 2001 that are connected to the header module 2002. In some aspects, different portions or areas of the GUI 2008 can correspond to particular modules 2001. For example, a first portion or area of the GUI 2008 can correspond to a first module and a second portion or area of the GUI 2008 can correspond to a second module. As different and/or additional modules 2001 are connected to the modular energy system stack, the GUI 2008 can adjust to accommodate the different and/or additional controls for each newly added module 2001 or remove controls for each module 2001 that is removed. Each portion of the display corresponding to a particular module connected to the header module 2002 can display controls, data, user prompts, and/or other information corresponding to that module. For example, in FIG. 30, a first or upper portion 2052 of the depicted GUI 2008 displays controls and data associated with an energy module 2004 that is connected to the header module 2002. In particular, the first portion 2052 of the GUI 2008 for the energy module 2004 provides first widget 2056a corresponding to the bipolar port 2014, a second widget 2056b corresponding to the first monopolar port 2016a, a third widget 2056c corresponding to the second monopolar port 2016b, and a fourth widget 2056d corresponding to the combination energy port 2020. Each of these widgets 2056a–d provides data related to its corresponding port of the port assembly 2012 and controls for controlling the modes and other features of the energy modality delivered by the energy module 2004 through the respective port of the port assembly 2012. For example, the widgets 2056a–d can be configured to display the power level of the surgical instrument connected to the respective port, change the operational mode of the surgical instrument connected to the respective port (e.g., change a surgical instrument from a first power level to a second power level and/or change a monopolar surgical instrument from a “spray” mode to a “blend” mode), and so on.

[0254] In one aspect, the header module 2002 can include various physical controls 2011 in addition to or in lieu of the GUI 2008. Such physical controls 2011 can include, for example, a power button that controls the activation of each module 2001 that is connected to the header module 2002 in the modular energy system 2000. Alternatively, the power button can be displayed as part of the GUI 2008. Therefore, the header module 2002 can serve as a single point of contact and obviate the need to individually activate and deactivate each individual module 2001 from which the modular energy system 2000 is constructed.

[0255] In one aspect, the header module 2002 can display still images, videos, animations, and/or information associated with the surgical modules 2001 of which the modular energy system 2000 is constructed or the surgical devices that are communicably coupled to the modular energy system 2000. The still images and/or videos displayed by the header module 2002 can be received from an endoscope or another visualization device that is communicably coupled to the modular energy system 2000. The animations and/or

information of the GUI 2008 can be overlaid on or displayed adjacent to the images or video feed.

[0256] In one aspect, the modules 2001 other than the header module 2002 can be configured to likewise relay information to users. For example, the energy module 2004 can include light assemblies 2015 disposed about each of the ports of the port assembly 2012. The light assemblies 2015 can be configured to relay information to the user regarding the port according to their color or state (e.g., flashing). For example, the light assemblies 2015 can change from a first color to a second color when a plug is fully seated within the respective port. In one aspect, the color or state of the light assemblies 2015 can be controlled by the header module 2002. For example, the header module 2002 can cause the light assembly 2015 of each port to display a color corresponding to the color display for the port on the GUI 2008.

[0257] FIG. 31 is a block diagram of a stand-alone hub configuration of a modular energy system 3000, in accordance with at least one aspect of the present disclosure and FIG. 32 is a block diagram of a hub configuration of a modular energy system 3000 integrated with a surgical control system 3010, in accordance with at least one aspect of the present disclosure. As depicted in FIGS. 31 and 32, the modular energy system 3000 can be either utilized as stand-alone units or integrated with a surgical control system 3010 that controls and/or receives data from one or more surgical hub units. In the examples illustrated in FIGS. 31 and 32, the integrated header/UI module 3002 of the modular energy system 3000 includes a header module and a UI module integrated together as a singular module. In other aspects, the header module and the UI module can be provided as separate components that are communicatively coupled through a data bus 3008.

[0258] As illustrated in FIG. 31, an example of a stand-alone modular energy system 3000 includes an integrated header module/user interface (UI) module 3002 coupled to an energy module 3004. Power and data are transmitted between the integrated header/UI module 3002 and the energy module 3004 through a power interface 3006 and a data interface 3008. For example, the integrated header/UI module 3002 can transmit various commands to the energy module 3004 through the data interface 3008. Such commands can be based on user inputs from the UI. As a further example, power may be transmitted to the energy module 3004 through the power interface 3006.

[0259] In FIG. 32, a surgical hub configuration includes a modular energy system 3000 integrated with a control system 3010 and an interface system 3022 for managing, among other things, data and power transmission to and/or from the modular energy system 3000. The modular energy system depicted in FIG. 32 includes an integrated header module/UI module 3002, a first energy module 3004, and a second energy module 3012. In one example, a data transmission pathway is established between the system control unit 3024

of the control system 3010 and the second energy module 3012 through the first energy module 3004 and the header/UI module 3002 through a data interface 3008. In addition, a power pathway extends between the integrated header/UI module 3002 and the second energy module 3012 through the first energy module 3004 through a power interface 3006. In other words, in one aspect, the first energy module 3004 is configured to function as a power and data interface between the second energy module 3012 and the integrated header/UI module 3002 through the power interface 3006 and the data interface 3008. This arrangement allows the modular energy system 3000 to expand by seamlessly connecting additional energy modules to energy modules 3004, 3012 that are already connected to the integrated header/UI module 3002 without the need for dedicated power and energy interfaces within the integrated header/UI module 3002.

[0260] The system control unit 3024, which may be referred to herein as a control circuit, control logic, microprocessor, microcontroller, logic, or FPGA, or various combinations thereof, is coupled to the system interface 3022 via energy interface 3026 and instrument communication interface 3028. The system interface 3022 is coupled to the first energy module 3004 via a first energy interface 3014 and a first instrument communication interface 3016. The system interface 3022 is coupled to the second energy module 3012 via a second energy interface 3018 and a second instrument communication interface 3020. As additional modules, such as additional energy modules, are stacked in the modular energy system 3000, additional energy and communications interfaces are provided between the system interface 3022 and the additional modules.

[0261] As described in more detail hereinbelow, the energy modules 3004, 3012 are connectable to a hub and can be configured to generate electrosurgical energy (e.g., bipolar or monopolar), ultrasonic energy, or a combination thereof (referred to herein as an “advanced energy” module) for a variety of energy surgical instruments. Generally, the energy modules 3004, 3012 include hardware/software interfaces, an ultrasonic controller, an advanced energy RF controller, bipolar RF controller, and control algorithms executed by the controller that receives outputs from the controller and controls the operation of the various energy modules 3004, 3012 accordingly. In various aspects of the present disclosure, the controllers described herein may be implemented as a control circuit, control logic, microprocessor, microcontroller, logic, or FPGA, or various combinations thereof.

[0262] FIGS. 33-35 are block diagrams of various modular energy systems connected together to form a hub, in accordance with at least one aspect of the present disclosure. FIGS. 33-35 depict various diagrams (e.g., circuit or control diagrams) of hub modules. The modular energy system 3000 includes multiple energy modules 3004 (FIG. 34), 3012 (FIG. 35), a header module 3150 (FIG. 35), a UI module 3030 (FIG. 33), and a communications module 3032 (FIG. 33), in accordance with at least one aspect of the present disclosure. The

UI module 3030 includes a touch screen 3046 displaying various relevant information and various user controls for controlling one or more parameters of the modular energy system 3000. The UI module 3030 is attached to the top header module 3150, but is separately housed so that it can be manipulated independently of the header module 3150. For example, the UI module 3030 can be picked up by a user and/or reattached to the header module 3150. Additionally, or alternatively, the UI module 3030 can be slightly moved relative to the header module 3150 to adjust its position and/or orientation. For example, the UI module 3030 can be tilted and/or rotated relative to the header module 3150.

[0263] In some aspects, the various hub modules can include light piping around the physical ports to communicate instrument status and also connect on-screen elements to corresponding instruments. Light piping is one example of an illumination technique that may be employed to alert a user to a status of a surgical instrument attached/connected to a physical port. In one aspect, illuminating a physical port with a particular light directs a user to connect a surgical instrument to the physical port. In another example, illuminating a physical port with a particular light alerts a user to an error related an existing connection with a surgical instrument.

[0264] Turning to FIG. 33, there is shown a block diagram of a user interface (UI) module 3030 coupled to a communications module 3032 via a pass-through hub connector 3034, in accordance with at least one aspect of the present disclosure. The UI module 3030 is provided as a separate component from a header module 3150 (shown in FIG. 35) and may be communicatively coupled to the header module 3150 via a communications module 3032, for example. In one aspect, the UI module 3030 can include a UI processor 3040 that is configured to represent declarative visualizations and behaviors received from other connected modules, as well as perform other centralized UI functionality, such as system configuration (e.g., language selection, module associations, etc.). The UI processor 3040 can be, for example, a processor or system on module (SOM) running a framework such as Qt, .NET WPF, Web server, or similar.

[0265] In the illustrated example, the UI module 3030 includes a touchscreen 3046, a liquid crystal display 3048 (LCD), and audio output 3052 (e.g., speaker, buzzer). The UI processor 3040 is configured to receive touchscreen inputs from a touch controller 3044 coupled between the touch screen 3046 and the UI processor 3040. The UI processor 3040 is configured to output visual information to the LCD display 3048 and to output audio information the audio output 3052 via an audio amplifier 3050. The UI processor 3040 is configured to interface to the communications module 3032 via a switch 3042 coupled to the pass-through hub connector 3034 to receive, process, and forward data from the source device to the destination device and control data communication therebetween. DC power is supplied to the UI module 3030 via DC/DC converter modules 3054. The DC power is

passed through the pass-through hub connector 3034 to the communications module 3032 through the power bus 3006. Data is passed through the pass-through hub connector 3034 to the communications module 3032 through the data bus 3008. Switches 3042, 3056 receive, process, and forward data from the source device to the destination device.

[0266] Continuing with FIG. 33, the communications module 3032, as well as various surgical hubs and/or surgical systems can include a gateway 3058 that is configured to shuttle select traffic (i.e., data) between two disparate networks (e.g., an internal network and/or a hospital network) that are running different protocols. The communications module 3032 includes a first pass-through hub connector 3036 to couple the communications module 3032 to other modules. In the illustrated example, the communications module 3032 is coupled to the UI module 3030. The communications module 3032 is configured to couple to other modules (e.g., energy modules) via a second pass-through hub connector 3038 to couple the communications module 3032 to other modules via a switch 3056 disposed between the first and second pass-through hub connectors 3036, 3038 to receive, process, and forward data from the source device to the destination device and control data communication therebetween. The switch 3056 also is coupled to a gateway 3058 to communicate information between external communications ports and the UI module 3030 and other connected modules. The gateway 3058 may be coupled to various communications modules such as, for example, an Ethernet module 3060 to communicate to a hospital or other local network, a universal serial bus (USB) module 3062, a WiFi module 3064, and a Bluetooth module 3066, among others. The communications modules may be physical boards located within the communications module 3032 or may be a port to couple to remote communications boards.

[0267] In some aspects, all of the modules (i.e., detachable hardware) are controlled by a single UI module 3030 that is disposed on or integral to a header module. FIG. 35 shows a stand alone header module 3150 to which the UI module 3030 can be attached. FIGS. 31, 32, and 36 show an integrated header/UI Module 3002. Returning now to FIG. 33, in various aspects, by consolidating all of the modules into a single, responsive UI module 3002, the system provides a simpler way to control and monitor multiple pieces of equipment at once. This approach drastically reduces footprint and complexity in an operating room (OR).

[0268] Turning to FIG. 34, there is shown a block diagram of an energy module 3004, in accordance with at least one aspect of the present disclosure. The communications module 3032 (FIG. 33) is coupled to the energy module 3004 via the second pass-through hub connector 3038 of the communications module 3032 and a first pass-through hub connector 3074 of the energy module 3004. The energy module 3004 may be coupled to other modules, such as a second energy module 3012 shown in FIG. 35, via a second pass-through hub connector 3078. Turning back to FIG. 34, a switch 3076 disposed between the

first and second pass-through hub connectors 3074, 3078 receives, processes, and forwards data from the source device to the destination device and controls data communication therebetween. Data is received and transmitted through the data bus 3008. The energy module 3032 includes a controller 3082 to control various communications and processing functions of the energy module 3004.

[0269] DC power is received and transmitted by the energy module 3004 through the power bus 3006. The power bus 3006 is coupled to DC/DC converter modules 3138 to supply power to adjustable regulators 3084, 3107 and isolated DC/DC converter ports 3096, 3112, 3132.

[0270] In one aspect, the energy module 3004 can include an ultrasonic wideband amplifier 3086, which in one aspect may be a linear class H amplifier that is capable of generating arbitrary waveforms and drive harmonic transducers at low total harmonic distortion (THD) levels. The ultrasonic wideband amplifier 3086 is fed by a buck adjustable regulator 3084 to maximize efficiency and controlled by the controller 3082, which may be implemented as a digital signal processor (DSP) via a direct digital synthesizer (DDS), for example. The DDS can either be embedded in the DSP or implemented in the field-programmable gate array (FPGA), for example. The controller 3082 controls the ultrasonic wideband amplifier 3086 via a digital-to-analog converter 3106 (DAC). The output of the ultrasonic wideband amplifier 3086 is fed to an ultrasonic power transformer 3088, which is coupled to an ultrasonic energy output portion of an advanced energy receptacle 3100. Ultrasonic voltage (V) and current (I) feedback (FB) signals, which may be employed to compute ultrasonic impedance, are fed back to the controller 3082 via an ultrasonic VI FB transformer 3092 through an input portion of the advanced energy receptacle 3100. The ultrasonic voltage and current feedback signals are routed back to the controller 3082 through an analog-to-digital converter 3102 (A/D). Also coupled to the controller 3082 through the advanced energy receptacle 3100 is the isolated DC/DC converter port 3096, which receives DC power from the power bus 3006, and a medium bandwidth data port 3098.

[0271] In one aspect, the energy module 3004 can include a wideband RF power amplifier 3108, which in one aspect may be a linear class H amplifier that is capable of generating arbitrary waveforms and drive RF loads at a range of output frequencies. The wideband RF power amplifier 3108 is fed by an adjustable buck regulator 3107 to maximize efficiency and controlled by the controller 3082, which may be implemented as DSP via a DDS. The DDS can either be embedded in the DSP or implemented in the FPGA, for example. The controller 3082 controls the wideband RF amplifier 3086 via a DAC 3122. The output of the wideband RF power amplifier 3108 can be fed through RF selection relays 3124. The RF selection relays 3124 are configured to receive and selectively transmit the output signal of

the wideband RF power amplifier 3108 to various other components of the energy module 3004. In one aspect, the output signal of the wideband RF power amplifier 3108 can be fed through RF selection relays 3124 to an RF power transformer 3110, which is coupled to an RF output portion of a bipolar RF energy receptacle 3118. Bipolar RF voltage (V) and current (I) feedback (FB) signals, which may be employed to compute RF impedance, are fed back to the controller 3082 via an RF VI FB transformer 3114 through an input portion of the bipolar RF energy receptacle 3118. The RF voltage and current feedback signals are routed back to the controller 3082 through an A/D 3120. Also coupled to the controller 3082 through the bipolar RF energy receptacle 3118 is the isolated DC/DC converter port 3112, which receives DC power from the power bus 3006, and a low bandwidth data port 3116.

[0272] As described above, in one aspect, the energy module 3004 can include RF selection relays 3124 driven by the controller 3082 (e.g., FPGA) at rated coil current for actuation and can also be set to a lower hold-current via pulse-width modulation (PWM) to limit steady-state power dissipation. Switching of the RF selection relays 3124 is achieved with force guided (safety) relays and the status of the contact state is sensed by the controller 3082 as a mitigation for any single fault conditions. In one aspect, the RF selection relays 3124 are configured to be in a first state, where an output RF signal received from an RF source, such as the wideband RF power amplifier 3108, is transmitted to a first component of the energy module 3004, such as the RF power transformer 3110 of the bipolar energy receptacle 3118. In a second aspect, the RF selection relays 3124 are configured to be in a second state, where an output RF signal received from an RF source, such as the wideband RF power amplifier 3108, is transmitted to a second component, such as an RF power transformer 3128 of a monopolar energy receptacle 3136, described in more detail below. In a general aspect, the RF selection relays 3124 are configured to be driven by the controller 3082 to switch between a plurality of states, such as the first state and the second state, to transmit the output RF signal received from the RF power amplifier 3108 between different energy receptacles of the energy module 3004.

[0273] As described above, the output of the wideband RF power amplifier 3108 can also be fed through the RF selection relays 3124 to the wideband RF power transformer 3128 of the RF monopolar receptacle 3136. Monopolar RF voltage (V) and current (I) feedback (FB) signals, which may be employed to compute RF impedance, are fed back to the controller 3082 via an RF VI FB transformer 3130 through an input portion of the monopolar RF energy receptacle 3136. The RF voltage and current feedback signals are routed back to the controller 3082 through an A/D 3126. Also coupled to the controller 3082 through the monopolar RF energy receptacle 3136 is the isolated DC/DC converter port 3132, which receives DC power from the power bus 3006, and a low bandwidth data port 3134.

[0274] The output of the wideband RF power amplifier 3108 can also be fed through the RF selection relays 3124 to the wideband RF power transformer 3090 of the advanced energy receptacle 3100. RF voltage (V) and current (I) feedback (FB) signals, which may be employed to compute RF impedance, are fed back to the controller 3082 via an RF VI FB transformer 3094 through an input portion of the advanced energy receptacle 3100. The RF voltage and current feedback signals are routed back to the controller 3082 through an A/D 3104.

[0275] FIG. 35 is a block diagram of a second energy module 3012 coupled to a header module 3150, in accordance with at least one aspect of the present disclosure. The first energy module 3004 shown in FIG. 34 is coupled to the second energy module 3012 shown in FIG. 35 by coupling the second pass-through hub connector 3078 of the first energy module 3004 to a first pass-through hub connector 3074 of the second energy module 3012. In one aspect, the second energy module 3012 can be a similar energy module to the first energy module 3004, as is illustrated in FIG. 35. In another aspect, the second energy module 3012 can be a different energy module compared to the first energy module, such as an energy module illustrated in FIG. 37, described in more detail. The addition of the second energy module 3012 to the first energy module 3004 adds functionality to the modular energy system 3000.

[0276] The second energy module 3012 is coupled to the header module 3150 by connecting the pass-through hub connector 3078 to the pass-through hub connector 3152 of the header module 3150. In one aspect, the header module 3150 can include a header processor 3158 that is configured to manage a power button function 3166, software upgrades through the upgrade USB module 3162, system time management, and gateway to external networks (i.e., hospital or the cloud) via an Ethernet module 3164 that may be running different protocols. Data is received by the header module 3150 through the pass-through hub connector 3152. The header processor 3158 also is coupled to a switch 3160 to receive, process, and forward data from the source device to the destination device and control data communication therebetween. The header processor 3158 also is coupled to an OTS power supply 3156 coupled to a mains power entry module 3154.

[0277] FIG. 36 is a block diagram of a header/user interface (UI) module 3002 for a hub, such as the header module depicted in FIG. 33, in accordance with at least one aspect of the present disclosure. The header/UI module 3002 includes a header power module 3172, a header wireless module 3174, a header USB module 3176, a header audio/screen module 3178, a header network module 3180 (e.g., Ethernet), a backplane connector 3182, a header standby processor module 3184, and a header footswitch module 3186. These functional modules interact to provide the header/UI 3002 functionality. A header/UI controller 3170 controls each of the functional modules and the communication

therebetween including safety critical control logic modules 3230, 3232 coupled between the header/UI controller 3170 and an isolated communications module 3234 coupled to the header footswitch module 3186. A security co-processor 3188 is coupled to the header/UI controller 3170.

[0278] The header power module 3172 includes a mains power entry module 3190 coupled to an OTS power supply unit 3192 (PSU). Low voltage direct current (e.g., 5V) standby power is supplied to the header/UI module 3002 and other modules through a low voltage power bus 3198 from the OTS PSU 3192. High voltage direct current (e.g., 60V) is supplied to the header/UI module 3002 through a high voltage bus 3200 from the OTS PSU 3192. The high voltage DC supplies DC/DC converter modules 3196 as well as isolated DC/DC converter modules 3236. A standby processor 3204 of the header/standby module 3184 provides a PSU/enable signal 3202 to the OTS PSU 3192.

[0279] The header wireless module 3174 includes a WiFi module 3212 and a Bluetooth module 3214. Both the WiFi module 3212 and the Bluetooth module 3214 are coupled to the header/UI controller 3170. The Bluetooth module 3214 is used to connect devices without using cables and the Wi-Fi module 3212 provides high-speed access to networks such as the Internet and can be employed to create a wireless network that can link multiple devices such as, for examples, multiple energy modules or other modules and surgical instruments, among other devices located in the operating room. Bluetooth is a wireless technology standard that is used to exchange data over short distances, such as, less than 30 feet.

[0280] The header USB module 3176 includes a USB port 3216 coupled to the header/UI controller 3170. The USB module 3176 provides a standard cable connection interface for modules and other electronics devices over short-distance digital data communications. The USB module 3176 allows modules comprising USB devices to be connected to each other with and transfer digital data over USB cables.

[0281] The header audio/screen module 3178 includes a touchscreen 3220 coupled to a touch controller 3218. The touch controller 3218 is coupled to the header/UI controller 3170 to read inputs from the touchscreen 3220. The header/UI controller 3170 drives an LCD display 3224 through a display/port video output signal 3222. The header/UI controller 3170 is coupled to an audio amplifier 3226 to drive one or more speakers 3228.

[0282] In one aspect, the header/UI module 3002 provides a touchscreen 3220 user interface configured to control modules connected to one control or header module 3002 in a modular energy system 3000. The touchscreen 3220 can be used to maintain a single point of access for the user to adjust all modules connected within the modular energy system 3000. Additional hardware modules (e.g., a smoke evacuation module) can appear at the bottom of the user interface LCD display 3224 when they become connected to the

header/UI module 3002, and can disappear from the user interface LCD display 3224 when they are disconnected from the header/UI module 3002.

[0283] Further, the user touchscreen 3220 can provide access to the settings of modules attached to the modular energy system 3000. Further, the user interface LCD display 3224 arrangement can be configured to change according to the number and types of modules that are connected to the header/UI module 3002. For example, a first user interface can be displayed on the LCD display 3224 for a first application where one energy module and one smoke evacuation module are connected to the header/UI module 3002, and a second user interface can be displayed on the LCD display 3224 for a second application where two energy modules are connected to the header/UI module 3002. Further, the user interface can alter its display on the LCD display 3224 as modules are connected and disconnected from the modular energy system 3000.

[0284] In one aspect, the header/UI module 3002 provides a user interface LCD display 3224 configured to display on the LCD display coloring corresponds to the port lighting. In one aspect, the coloring of the instrument panel and the LED light around its corresponding port will be the same or otherwise correspond with each other. Each color can, for example, convey a unique meaning. This way, the user will be able to quickly assess which instrument the indication is referring to and the nature of the indication. Further, indications regarding an instrument can be represented by the changing of color of the LED light lined around its corresponding port and the coloring of its module. Still further, the message on screen and hardware/software port alignment can also serve to convey that an action must be taken on the hardware, not on the interface. In various aspects, all other instruments can be used while alerts are occurring on other instruments. This allows the user to be able to quickly assess which instrument the indication is referring to and the nature of the indication.

[0285] In one aspect, the header/UI module 3002 provides a user interface screen configured to display on the LCD display 3224 to present procedure options to a user. In one aspect, the user interface can be configured to present the user with a series of options (which can be arranged, e.g., from broad to specific). After each selection is made, the modular energy system 3000 presents the next level until all selections are complete. These settings could be managed locally and transferred via a secondary means (such as a USB thumb drive). Alternatively, the settings could be managed via a portal and automatically distributed to all connected systems in the hospital.

[0286] The procedure options can include, for example, a list of factory preset options categorized by specialty, procedure, and type of procedure. Upon completing a user selection, the header module can be configured to set any connected instruments to factory-preset settings for that specific procedure. The procedure options can also include, for example, a list of surgeons, then subsequently, the specialty, procedure, and type. Once a

user completes a selection, the system may suggest the surgeon's preferred instruments and set those instrument's settings according to the surgeon's preference (i.e., a profile associated with each surgeon storing the surgeon's preferences).

[0287] In one aspect, the header/UI module 3002 provides a user interface screen configured to display on the LCD display 3224 critical instrument settings. In one aspect, each instrument panel displayed on the LCD display 3224 of the user interface corresponds, in placement and content, to the instruments plugged into the modular energy system 3000. When a user taps on a panel, it can expand to reveal additional settings and options for that specific instrument and the rest of the screen can, for example, darken or otherwise be de-emphasized.

[0288] In one aspect, the header/UI module 3002 provides an instrument settings panel of the user interface configured to comprise/display controls that are unique to an instrument and allow the user to increase or decrease the intensity of its output, toggle certain functions, pair it with system accessories like a footswitch connected to header footswitch module 3186, access advanced instrument settings, and find additional information about the instrument. In one aspect, the user can tap/select an "Advanced Settings" control to expand the advanced settings drawer displayed on the user interface LCD display 3224. In one aspect, the user can then tap/select an icon at the top right-hand corner of the instrument settings panel or tap anywhere outside of the panel and the panel will scale back down to its original state. In these aspects, the user interface is configured to display on the LCD display 3224 only the most critical instrument settings, such as power level and power mode, on the ready/home screen for each instrument panel. This is to maximize the size and readability of the system from a distance. In some aspects, the panels and the settings within can be scaled proportionally to the number of instruments connected to the system to further improve readability. As more instruments are connected, the panels scale to accommodate a greater amount of information.

[0289] The header network module 3180 includes a plurality of network interfaces 3264, 3266, 3268 (e.g., Ethernet) to network the header/UI module 3002 to other modules of the modular energy system 3000. In the illustrated example, one network interface 3264 may be a 3rd party network interface, another network interface 3266 may be a hospital network interface, and yet another network interface 3268 may be located on the backplane network interface connector 3182.

[0290] The header standby processor module 3184 includes a standby processor 3204 coupled to an On/Off switch 3210. The standby processor 3204 conducts an electrical continuity test by checking to see if electrical current flows in a continuity loop 3206. The continuity test is performed by placing a small voltage across the continuity loop 3206. A serial bus 3208 couples the standby processor 3204 to the backplane connector 3182.

[0291] The header footswitch module 3186 includes a controller 3240 coupled to a plurality of analog footswitch ports 3254, 3256, 3258 through a plurality of corresponding presence/ID and switch state modules 3242, 3244, 3246, respectively. The controller 3240 also is coupled to an accessory port 3260 via a presence/ID and switch state module 3248 and a transceiver module 3250. The accessory port 3260 is powered by an accessory power module 3252. The controller 3240 is coupled to header/UI controller 3170 via an isolated communication module 3234 and first and second safety critical control modules 3230, 3232. The header footswitch module 3186 also includes DC/DC converter modules 3238.

[0292] In one aspect, the header/UI module 3002 provides a user interface screen configured to display on the LCD display 3224 for controlling a footswitch connected to any one of the analog footswitch ports 3254, 3256, 3258. In some aspects, when the user plugs in a non hand-activated instrument into any one of the analog footswitch ports 3254, 3256, 3258, the instrument panel appears with a warning icon next to the footswitch icon. The instrument settings can be, for example, greyed out, as the instrument cannot be activated without a footswitch.

[0293] When the user plugs in a footswitch into any one of the analog footswitch ports 3254, 3256, 3258, a pop-up appears indicating that a footswitch has been assigned to that instrument. The footswitch icon indicates that a footswitch has been plugged in and assigned to the instrument. The user can then tap/select on that icon to assign, reassign, unassign, or otherwise change the settings associated with that footswitch. In these aspects, the system is configured to automatically assign footswitches to non hand-activated instruments using logic, which can further assign single or double-pedal footswitches to the appropriate instrument. If the user wants to assign/reassign footswitches manually there are two flows that can be utilized.

[0294] In one aspect, the header/UI module 3002 provides a global footswitch button. Once the user taps on the global footswitch icon (located in the upper right of the user interface LCD display 3224), the footswitch assignment overlay appears and the contents in the instrument modules dim. A (e.g., photo-realistic) representation of each attached footswitch (dual or single-pedal) appears on the bottom if unassigned to an instrument or on the corresponding instrument panel. Accordingly, the user can drag and drop these illustrations into, and out of, the boxed icons in the footswitch assignment overlay to assign, unassign, and reassign footswitches to their respective instruments.

[0295] In one aspect, the header/UI module 3002 provides a user interface screen displayed on the LCD display 3224 indicating footswitch auto-assignment, in accordance with at least one aspect of the present disclosure. As discussed above, the modular energy system 3000 can be configured to auto-assign a footswitch to an instrument that does not have hand activation. In some aspects, the header/UI module 3002 can be configured to

correlate the colors displayed on the user interface LCD display 3224 to the lights on the modules themselves as means of tracking physical ports with user interface elements.

[0296] In one aspect, the header/UI module 3002 may be configured to depict various applications of the user interface with differing number of modules connected to the modular energy system 3000. In various aspects, the overall layout or proportion of the user interface elements displayed on the LCD display 3224 can be based on the number and type of instruments plugged into the header/UI module 3002. These scalable graphics can provide the means to utilize more of the screen for better visualization.

[0297] In one aspect, the header/UI module 3002 may be configured to depict a user interface screen on the LCD display 3224 to indicate which ports of the modules connected to the modular energy system 3000 are active. In some aspects, the header/UI module 3002 can be configured to illustrate active versus inactive ports by highlighting active ports and dimming inactive ports. In one aspect, ports can be represented with color when active (e.g., monopolar tissue cut with yellow, monopolar tissue coagulation with blue, bipolar tissue cut with blue, advanced energy tissue cut with warm white, and so on). Further, the displayed color will match the color of the light piping around the ports. The coloring can further indicate that the user cannot change settings of other instruments while an instrument is active. As another example, the header/UI module 3002 can be configured to depict the bipolar, monopolar, and ultrasonic ports of a first energy module as active and the monopolar ports of a second energy module as likewise active.

[0298] In one aspect, the header/UI module 3002 can be configured to depict a user interface screen on the LCD display 3224 to display a global settings menu. In one aspect, the header/UI module 3002 can be configured to display a menu on the LCD display 3224 to control global settings across any modules connected to the modular energy system 3000. The global settings menu can be, for example, always displayed in a consistent location (e.g., always available in upper right hand corner of main screen).

[0299] In one aspect, the header/UI module 3002 can be configured to depict a user interface screen on the LCD display 3224 configured to prevent changing of settings while a surgical instrument is in use. In one example, the header/UI module 3002 can be configured to prevent settings from being changed via a displayed menu when a connected instrument is active. The user interface screen can include, for example, an area (e.g., the upper left hand corner) that is reserved for indicating instrument activation while a settings menu is open. In one aspect, a user has opened the bipolar settings while monopolar coagulation is active. In one aspect, the settings menu could then be used once the activation is complete. In one aspect, the header/UI module 3002 can be is configured to never overlay any menus or other information over the dedicated area for indicating critical instrument information in order to maintain display of critical information.

[0300] In one aspect, the header/UI module 3002 can be configured to depict a user interface screen on the LCD display 3224 configured to display instrument errors. In one aspect, instrument error warnings may be displayed on the instrument panel itself, allowing user to continue to use other instruments while a nurse troubleshoots the error. This allows users to continue the surgery without the need to stop the surgery to debug the instrument.

[0301] In one aspect, the header/UI module 3002 can be configured to depict a user interface screen on the LCD display 3224 to display different modes or settings available for various instruments. In various aspects, the header/UI module 3002 can be configured to display settings menus that are appropriate for the type or application of surgical instrument(s) connected to the stack/hub. Each settings menu can provide options for different power levels, energy delivery profiles, and so on that are appropriate for the particular instrument type. In one aspect, the header/UI module 3002 can be configured to display different modes available for bipolar, monopolar cut, and monopolar coagulation applications.

[0302] In one aspect, the header/UI module 3002 can be configured to depict a user interface screen on the LCD display 3224 to display pre-selected settings. In one aspect, the header/UI module 3002 can be configured to receive selections for the instrument/device settings before plugging in instruments so that the modular energy system 3000 is ready before the patient enters the operating room. In one aspect, the user can simply click a port and then change the settings for that port. In the depicted aspect, the selected port appears as faded to indicate settings are set, but no instrument is plugged into that port.

[0303] FIG. 37 is a block diagram of an energy module 3270 for a hub, such as the energy module depicted in FIGS. 31, 32, 34, and 35, in accordance with at least one aspect of the present disclosure. The energy module 3270 is configured to couple to a header module, header/UI module, and other energy modules via the first and second pass-through hub connectors 3272, 3276. A switch 3076 disposed between the first and second pass-through hub connectors 3272, 3276 receives, processes, and forwards data from the source device to the destination device and controls data communication therebetween. Data is received and transmitted through the data bus 3008. The energy module 3270 includes a controller 3082 to control various communications and processing functions of the energy module 3270.

[0304] DC power is received and transmitted by the energy module 3270 through the power bus 3006. The power bus 3006 is coupled to the DC/DC converter modules 3138 to supply power to adjustable regulators 3084, 3107 and isolated DC/DC converter ports 3096, 3112, 3132.

[0305] In one aspect, the energy module 3270 can include an ultrasonic wideband amplifier 3086, which in one aspect may be a linear class H amplifier that is capable of

generating arbitrary waveforms and drive harmonic transducers at low total harmonic distortion (THD) levels. The ultrasonic wideband amplifier 3086 is fed by a buck adjustable regulator 3084 to maximize efficiency and controlled by the controller 3082, which may be implemented as a digital signal processor (DSP) via a direct digital synthesizer (DDS), for example. The DDS can either be embedded in the DSP or implemented in the field-programmable gate array (FPGA), for example. The controller 3082 controls the ultrasonic wideband amplifier 3086 via a digital-to-analog converter 3106 (DAC). The output of the ultrasonic wideband amplifier 3086 is fed to an ultrasonic power transformer 3088, which is coupled to an ultrasonic energy output portion of the advanced energy receptacle 3100. Ultrasonic voltage (V) and current (I) feedback (FB) signals, which may be employed to compute ultrasonic impedance, are fed back to the controller 3082 via an ultrasonic VI FB transformer 3092 through an input portion of the advanced energy receptacle 3100. The ultrasonic voltage and current feedback signals are routed back to the controller 3082 through an analog multiplexer 3280 and a dual analog-to-digital converter 3278 (A/D). In one aspect, the dual A/D 3278 has a sampling rate of 80 MSPS. Also coupled to the controller 3082 through the advanced energy receptacle 3100 is the isolated DC/DC converter port 3096, which receives DC power from the power bus 3006, and a medium bandwidth data port 3098.

[0306] In one aspect, the energy module 3270 can include a plurality of wideband RF power amplifiers 3108, 3286, 3288, among others, which in one aspect, each of the wideband RF power amplifiers 3108, 3286, 3288 may be linear class H amplifiers capable of generating arbitrary waveforms and drive RF loads at a range of output frequencies. Each of the wideband RF power amplifiers 3108, 3286, 3288 are fed by an adjustable buck regulator 3107 to maximize efficiency and controlled by the controller 3082, which may be implemented as DSP via a DDS. The DDS can either be embedded in the DSP or implemented in the FPGA, for example. The controller 3082 controls the first wideband RF power amplifier 3108 via a DAC 3122.

[0307] Unlike the energy modules 3004, 3012 shown and described in FIGS. 34 and 35, the energy module 3270 does not include RF selection relays configured to receive an RF output signal from the adjustable buck regulator 3107. In addition, unlike the energy modules 3004, 3012 shown and described in FIGS. 34 and 35, the energy module 3270 includes a plurality of wideband RF power amplifiers 3108, 3286, 3288 instead of a single RF power amplifier. In one aspect, the adjustable buck regulator 3107 can switch between a plurality of states, in which the adjustable buck regulator 3107 outputs an output RF signal to one of the plurality of wideband RF power amplifiers 3108, 3286, 3288 connected thereto. The controller 3082 is configured to switch the adjustable buck regulator 3107 between the plurality of states. In a first state, the controller drives the adjustable buck regulator 3107 to

output an RF energy signal to the first wideband RF power amplifier 3108. In a second state, the controller drives the adjustable buck regulator 3107 to output an RF energy signal to the second wideband RF power amplifier 3286. In a third state, the controller drives the adjustable buck regulator 3107 to output an RF energy signal to the third wideband RF power amplifier 3288.

[0308] The output of the first wideband RF power amplifier 3108 can be fed to an RF power transformer 3090, which is coupled to an RF output portion of an advanced energy receptacle 3100. RF voltage (V) and current (I) feedback (FB) signals, which may be employed to compute RF impedance, are fed back to the controller 3082 via RF VI FB transformers 3094 through an input portion of the advanced energy receptacle 3100. The RF voltage and current feedback signals are routed back to the controller 3082 through the RF VI FB transformers 3094, which are coupled to an analog multiplexer 3284 and a dual A/D 3282 coupled to the controller 3082. In one aspect, the dual A/D 3282 has a sampling rate of 80 MSPS.

[0309] The output of the second RF wideband power amplifier 3286 is fed through an RF power transformer 3128 of the RF monopolar receptacle 3136. Monopolar RF voltage (V) and current (I) feedback (FB) signals, which may be employed to compute RF impedance, are fed back to the controller 3082 via RF VI FB transformers 3130 through an input portion of the monopolar RF energy receptacle 3136. The RF voltage and current feedback signals are routed back to the controller 3082 through the analog multiplexer 3284 and the dual A/D 3282. Also coupled to the controller 3082 through the monopolar RF energy receptacle 3136 is the isolated DC/DC converter port 3132, which receives DC power from the power bus 3006, and a low bandwidth data port 3134.

[0310] The output of the third RF wideband power amplifier 3288 is fed through an RF power transformer 3110 of a bipolar RF receptacle 3118. Bipolar RF voltage (V) and current (I) feedback (FB) signals, which may be employed to compute RF impedance, are fed back to the controller 3082 via RF VI FB transformers 3114 through an input portion of the bipolar RF energy receptacle 3118. The RF voltage and current feedback signals are routed back to the controller 3082 through the analog multiplexer 3280 and the dual A/D 3278. Also coupled to the controller 3082 through the bipolar RF energy receptacle 3118 is the isolated DC/DC converter port 3112, which receives DC power from the power bus 3006, and a low bandwidth data port 3116.

[0311] A contact monitor 3290 is coupled to an NE receptacle 3292. Power is fed to the NE receptacle 3292 from the monopolar receptacle 3136.

[0312] In one aspect, with reference to FIGS. 31-37, the modular energy system 3000 can be configured to detect instrument presence in a receptacle 3100, 3118, 3136 via a photo-interrupter, magnetic sensor, or other non-contact sensor integrated into the receptacle

3100, 3118, 3136. This approach prevents the necessity of allocating a dedicated presence pin on the MTD connector to a single purpose and instead allows multi-purpose functionality for MTD signal pins 6-9 while continuously monitoring instrument presence.

[0313] In one aspect, with reference to FIGS. 31-37, the modules of the modular energy system 3000 can include an optical link allowing high speed communication (10 - 50Mb/s) across the patient isolation boundary. This link would carry device communications, mitigation signals (watchdog, etc.), and low bandwidth run-time data. In some aspects, the optical link(s) will not contain real-time sampled data, which can be done on the non-isolated side.

[0314] In one aspect, with reference to FIGS. 31-37, the modules of the modular energy system 3000 can include a multi-function circuit block which can: (i) read presence resistor values via A/D and current source, (ii) communicate with legacy instruments via hand switch Q protocols, (iii) communicate with instruments via local bus 1-Wire protocols, and (iv) communicate with CAN FD-enabled surgical instruments. When a surgical instrument is properly identified by an energy generator module, the relevant pin functions and communications circuits are enabled, while the other unused functions are disabled and set to a high impedance state.

[0315] In one aspect, with reference to FIGS. 31-37, the modules of the modular energy system 3000 can include an amplifier pulse/stimulation/auxiliary DC amplifier. This is a flexible-use amplifier based on a full-bridge output and incorporates functional isolation. This allows its differential output to be referenced to any output connection on the applied part (except, in some aspects, a monopolar active electrode). The amplifier output can be either small signal linear (pulse/stim) with waveform drive provided by a DAC or a square wave drive at moderate output power for DC applications such as DC motors, illumination, FET drive, etc. The output voltage and current are sensed with functionally isolated voltage and current feedback to provide accurate impedance and power measurements to the FPGA. Paired with a CAN FD-enabled instrument, this output can offer motor/motion control drive, while position or velocity feedback is provided by the CAN FD interface for closed loop control.

[0316] As described in greater detail herein, a modular surgical system comprises a header module and one or more functional or surgical modules. In various instances, the modular surgical system is a modular energy system. In various instances, the surgical modules include energy modules, communication modules, and/or user interface modules; however, the surgical modules are envisioned to be any suitable type of functional or surgical module for use with the modular surgical system.

[0317] The header module is configured to control the system-wide settings of each module/component connected thereto. In order to effectively control the modules, it is

important for the header module to know and/or be aware of the physical location of each module in the system. In various instances, the physical location of each connected module is recognized and/or determined by the header module so that user interface content for each module can be arranged with a 1:1 association to the physical location of each module. In various instances, the physical location of each connected module is recognized by the header module so that a unique address can be assigned to each module. Assignment of a unique address allows the module to be used with a mitigated communication bus.

[0318] FIG. 38 illustrates a modular identification circuit 7500 of a modular surgical system, or a modular energy system. Among other things, the modular identification circuit 7500 is utilized to identify the physical location of one or more modules within a stack configuration of the modular surgical system. In various instances, the modular identification circuit 7500 is configured to detect the total number of modules present within the stack configuration. As shown in FIG. 38, the modular surgical system comprises a header module 7510, a first module 7520, and a second, or last, module 7530. The header module 7510 comprises a current source 7512. A current loop extends from the header module 7510 through each module of the modular surgical system, ultimately returning to the header module 7510. In order for the current to travel through each module of the modular surgical system, each module must be appropriately connected to the modular surgical system and/or each module must be functional.

[0319] The header module 7510 is stacked at a top position of the modular surgical system as shown in FIG. 38. A first module 7520 is shown stacked below the header module 7510 in an adjacent position. A second, or last, module 7530 is shown stacked below the first module 7520. In other words, the modular surgical system depicted in FIG. 38 comprises a stack configuration (from top to bottom) of: the header module 7510; the first module 7520; and the last module 7530.

[0320] The first module 7520 comprises a first pin 7523 and a normally-closed (NC) relay 7522. The NC relay 7522 is configurable in an open state and a closed state. When the first module 7520 is the only modular component connected to the header module 7510 and/or the first module 7520 is located at bottom-most position within the stack configuration, the first pin 7523 is open and the relay 7522 is closed. In such instances, the current runs from the header module 7510 through the first module 7520 and back to the header module 7510. In various instances, the first pin 7523 is open and the relay 7522 is closed when the first module 7520 is located at bottom-most position within the stack configuration. For example, the first module 7520 could be the only modular component connected to the header module 7510 and/or one or more modules can be positioned between the first module 7520 and the header module 7510.

[0321] The second, or last, module 7530 comprises a second pin 7233 and a normally-closed (NC) relay 7532. The NC relay 7532 is configurable in an open state and a closed state. When the second module 7530 is the only modular component connected to the header module 7510, the second pin 7533 is open and the relay 7532 is closed. In such instances, the current runs from the header module 7510 through the second module 7530 and back to the header module 7510. In various instances, such as shown in FIG. 38, the modular surgical system comprises a modular component, such as the first module 7520, positioned in between the second module 7530 and the header module 7510. The connection between the first module 7520 and the second module 7530 causes the first pin 7523 of the first module 7520 to be grounded and causes the NC relay 7522 to be in an open state. As the second module 7530 does not comprise any additional modular components connected and/or positioned underneath the second module 7530 in the stack configuration, the second pin 7233 is in the closed state. In such instances, the current runs from the header module 7510 through the first module 7520, from the first module 7520 through the second module 7520, from the second module 7520 back through the first module 7520, and from the first module 7520 back to the header module 7510.

[0322] The relay of the bottom functional modules is closed because its pin is open. In contrast, the relay of an intermediate functional module is open because its pin is grounded in a lower module chassis.

[0323] Each module adds series resistance to the current loop, creating a voltage divider. The first module 7520 comprises a first resistor 7524, and the second module 7530 comprises a second resistor 7534. The first resistor 7524 and the second resistor 7534 are placed in series with the current source 7512 of the header module 7510. By placing the resistors 7524, 7534 in series with the current source 7512, a voltage divider is created. The header module 7510 is configured to measure the total resistance in the loop to determine the total number of modules in the stack configuration and/or the modular surgical system.

[0324] By measuring the total voltage drop between the input and the output of the current source 7512, the header module 7510 is configured to detect the total number of modules present within the stack configuration. For example, the resistors 7524, 7534 have a resistance of 1 ohm. If the header module 7510 detects a total voltage drop of 1V, only 1 module is present and/or appropriately connected within the stack configuration. If the header module 7510 detects a total voltage drop of 2V, 2 modules are present and/or appropriately connected within the stack configuration. Such an ability of the header module 7510 provides a mitigation strategy, by providing the header module 7510 with a secondary means for detecting module quantity outside of a primary communication bus, such as, for example, an Ethernet cable.

[0325] Each module within the stack configuration is configured to measure the voltage from the current source 7512 of the header module 7510 to the low side of the module's resistor in the loop. By measuring the voltage drop between the current source 7512 of the header module 7510 and the low side of the module resistor, a module may detect its own physical position within the stack configuration. The header module comprises a differential amplifier 7516 and an analog to digital converter (ADC) 7518. The first module 7520 further comprises a differential amplifier 7526 and an ADC 7528. The second module 7530 further comprises a differential amplifier 7536 and an ADC 7538. It is envisioned that each module within the modular surgical system comprises a differential amplifier and an ADC for determining the voltage value at each of the modules. In the first module 7520, the differential amplifier 7526 is connected to a high side of the module 7520, which is a position in the module 7520 before the current passes through the resistor 7524. The differential amplifier 7526 is also connected to a low side of the module 7520, which is a position after the current has passed through the resistor 7524. The voltage drop between the header current source 7512 and the low side of the resistor 7524 is measured by the differential amplifier 7526 and is then passed to the ADC 7528. The ADC 7528 then uses this voltage drop to determine a physical location of the module 7520 within the stack configuration.

[0326] In a similar manner, the differential amplifier 7536 is connected to a high side of the second module 7530, which is a position in the module 7530 before the current passes through the resistor 7534. The differential amplifier 7536 is also connected to a low side of the module 7530, which is a position after the current has passed through the resistor 7534. The voltage drop between the header current source 7512 and the low side of the resistor 7534 is measured by the differential amplifier 7536 and is then passed to the ADC 7538. The ADC 7538 then uses this voltage drop to determine a physical location of the module 7530 within the stack configuration.

[0327] In the modular identification circuit 7500 illustrated in FIG. 38, the header module 7510 comprises a 1mA current source 7512. The header module is stacked on top of a first module 7520 and a second module 7530. As described above the first module 7520 comprises a 1k Ω resistor 7524, a differential amplifier 7526, and an ADC 7528. The second module 7530 comprises a 1k Ω resistor 7534, a differential amplifier 7536, and an ADC 7538. While a 1mA current source 7512 and 1k Ω resistors 7524, 7534 are shown, it is envisioned that any suitable combination of current sources and resistors can be used.

[0328] The 1mA current flows from the header module 7510 through the modules stacked therebelow. As discussed above, the high side of the differential amplifiers of the modules measure the voltage before the current passes through the resistor. The current from the header module 7510 flows through the high side of all of the differential amplifiers 7526, 7536 of the modules stack therebelow. Once the current reaches the last module of the

stack configuration, the current begins to flow back toward the header module. For example, in FIG. 38, once the 1mA current reaches the second module 7530, the 1mA current begins flowing back toward the header module 7510.

[0329] As the current flows back toward the header module 7510, the 1mA current passes across the 1k Ω resistor 7534 of the second module 7530, which results in a 1V voltage drop between the header current source 7512 and the resistor 7534. The differential amplifier 7536 of the second module 7530 is configured to measure this 1V voltage drop and determine a 1V voltage differential between the header current source 7512 and the low side of the resistor 7534 of the second module 7530. The differential amplifier 7536 can then transmit a signal corresponding to this voltage differential to the ADC 7538, which can interpret this signal and assign a corresponding address to the second module 7530. In the illustrated example, the 1V voltage differential signal is converted to a digital reading by the ADC 7538. The digital reading is interpreted by a controller that assigns a corresponding and/or unique address to the second module 7530. The assigned address corresponds to a physical location of the second module 7530 within the stack configuration with respect to the header module 7510.

[0330] After the current passes through the resistor 7534 of the second module 7530 of the module stack, the current continues to flow back toward the header module 7510. As the current flows from the second module 7530 toward the header module 7510, the 1mA current passes across the 1k Ω resistor 7524 of the first module 7520. The differential amplifier 7526 of the first module 7520 is configured to measure this voltage drop and determine a 2V voltage differential between the header current source 7512 and the low side of the resistor 7524 of the first module 7520. The differential amplifier 7526 can then transmit a signal corresponding to this voltage differential to the ADC 7528, which can interpret this signal and assign a corresponding address to the first module 7520. In the illustrated example, the 2V voltage differential signal is converted to a digital reading by the ADC 7528. The digital reading is interpreted by a controller that assigns a corresponding and/or unique address to the first module 7520. The assigned address corresponds to a physical location of the first module 7520 within the stack configuration with respect to the header module 7510.

[0331] In instances where additional modular components are positioned between the second module 7530 and the header module 7510, each differential amplifier and ADC of the remaining modules are configured to measure the voltage drop across its respective module resistors and assign corresponding "N" addresses until the current returns to the header module. An address is not assigned to the header module.

[0332] The circuit illustrates a header module stack at the top position of the modular energy system configuration. In the example circuit, "N" modules are shown stack below the

header module, where "N" represents any positive integer. While the example circuit illustrates two modules stack below the header module, more or fewer modules can be used.

[0333] In various instances, the module positioned at the bottom of the stack configuration is assigned an address "1" based on the detected voltage drop between the header current source and the low side of the module resistor. The next module measures a voltage drop of 2V and is assigned address "2", for example. The "Nth" module measures "N" V, and is assigned address N. In various aspects, the header module comprises a memory storing information indicating that the address "1" corresponds to a module at the bottom of the stack, and the module with the address "N" is on the top of the stack, wherein the bottom of the stack is furthest away from the header module, and wherein the top of the stack is closest to the header module.

[0334] As discussed in greater detail herein, in various instances, the modular surgical system further comprises a display screen, such as, for example, the display screen 2006. The display screen renders a graphical user interface for relaying information regarding the modules connected to the header module. In various instances, the display is configured to visually represent and/or communicate the determined physical location of each modular component within the stack configuration of the modular surgical system.

[0335] As described in greater detail herein, a modular surgical system comprises a header module, to control the system-wide settings of each module/component connected thereto. The header module can facilitate power transmission between the modules in the system. However, it is desirable for the header module to be able to verify the integrity of the connections between the one or more modules prior to applying power to the system.

[0336] Referring now to FIG. 39, a connection integrity circuit 7600 a modular surgical system, or a modular energy system, is shown. The connection integrity circuit 7600 causes a header module 7610 to detect an open circuit (no voltage difference across a current source) when: (1) there are no modules connected to the header module 7610; (2) there is a broken pin and/or a broken connection on one of the modules connected downstream; and/or (3) there is a faulty relay in the last module. The modular surgical system comprises a header module 7610 and two modules stack therebelow. The two modules comprise a first module 7620 and a second module 7630. While the illustrated circuit 7600 depicts two modules connected with the header module 7610, any suitable number of modules can be used and/or connected.

[0337] The header module 7610 is connected to a first module 7620 by way of a bridge connector. The input bridge connector 7622 of the first module 7620 comprises a first pin 7622a and a second pin 7622b. The first pin 7622a and the second pin 7622b of the input bridge connector 7622 are configured to connect to a corresponding first pin 7614a and second pin 7614b in an output bridge connector 7614 of the header module 7610. In

addition, the first module 7610 comprises an output bridge connector 7624 comprising a first pin 7624a and a second pin 7624b. The first and second pins 7624a, 7624b of the output bridge connector 7624 of the first module 7620 are configured to respectively connect to a first pin 7632a and a second pin 7632b of an input bridge connector 7632 of the next module in the stack, *i.e.*, the second module 7630. The second module 7630, similar to the first module 7620, comprises an output bridge connector 7634 that comprises first and second pins 7634a, 7634b. As the second module 7630 is the last module in the depicted stack, a shorting plug 7640 connects the first and second pins 7634a, 7634b of the output bridge connector 7634, thereby completing the circuit.

[0338] In order to verify the integrity of the connections of the modules with the header module 7610, a continuity loop is utilized. The header module 7610 comprises a current source 7612, which is configured to pass a current through the first pins 7614a, 7624a, 7634a of the modules in the stack and return the current to the header module 7610 through the second pins 7634b, 7624b, 7614b of the modules in the stack. The continuity loop allows the header module 7610 to detect a high resistance and/or an open connection in one of the module-to-module bridge connectors 7614, 7622, 7624, 7632, 7634.

[0339] In various instances, the connection integrity circuit 7600 comprises an operational amplifier 7616. The voltage output of the operational amplifier 7616 can be indicative of the integrity of the connection to all modules in its stack. In at least one example, an analogue to digital converter (“ADC”) 7618 can convert the voltage output of the operational amplifier 7616 into digital readings indicative of the integrity of the connection(s). The digital readings can be communicated to a controller that may issue an alert and/or disable power supply, for example, if the controller determines that the integrity of the connection is compromised. The alert can be issued through a user interface of the header module 7610 and can include instructions of how to properly connect the assembly of the stack, for example.

[0340] In various instances, the connection integrity circuit 7600 is configured to generate a first output indicative an uncompromised electrical connection to the modules in the stack. The connection integrity circuit 7600 is further configured to generate a second output, different than the first output, indicative of a compromised electrical connection between one or more modules in the stack.

[0341] As discussed above, the connection integrity circuit 7600 of FIG. 39 comprises a shorting plug 7640 attached to the first and second pins 7634a, 7634b of the second module 7630 to complete the circuit. Referring now to FIG. 40, a connection integrity circuit 7700 is shown that does not require a shorting plug. The circuit 7700 is similar to the circuit 7600 shown and described in FIG. 39 in that there is, among other things, a header module 7710 comprising a current source 7712, a first module 7720, and a second module 7730. As

discussed above, while two modules are depicted in connection with the header module, any suitable number of modules can be used and/or connected.

[0342] The header module 7710 is connected to the first module 7720 by way of a bridge connector. An input bridge connector 7722 of the first module 7720 comprises a first pin 7722a and a second pin 7722b. The first pin 7722a and the second pin 7722b of the input bridge connector 7722 are configured to connect to a corresponding first pin 7714a and second pin 7714b in an output bridge connector 7714 of the header module 7710. In addition, the first module 7710 comprises an output bridge connector 7724 comprising a first pin 7724a and a second pin 7724b. The first and second pins 7724a, 7724b of the output bridge connector 7724 of the first module 7720 are configured to respectively connect to a first pin 7732a and a second pin 7732b of an input bridge connector 7732 of the next module in the stack, *i.e.*, the second module 7730. The second module 7730, similar to the first module 7720, comprises an output bridge connector 7734 that comprises first and second pins 7734a, 7734b.

[0343] In order to verify the integrity of the connections of the modules with the header module 7710, a continuity loop is utilized. The header module 7710 comprises a current source 7712, which is configured to pass a current through the first pins 7714a, 7724a, 7734a of the modules in the stack and return the current to the header module 7710 through the second pins 7734b, 7724b, 7714b of the modules in the stack. The continuity loop allows the header module 7610 to detect a high resistance and/or an open connection in one of the module-to-module bridge connectors 7714, 7722, 7724, 7732, 7734.

[0344] As illustrated in FIG. 40, instead of connecting a shorting plug to the first and second pins 7734a, 7734b of the second module 7730, an NC relay can be incorporated into each module. More specifically, the first module 7720 comprises a NC relay 7728 and the second module 7730 comprises a NC relay 7738. The NC relays are normally closed; however, the NC relays are driven open when a pin in the adjacent module is pulled down to ground. Thus, in the depicted circuit, an NC relay is driven open in all modules except the last module, as the control pin is not pulled to ground. In various instances, the NC relays 7728, 7738 can be replaced by an N-Channel MOSFET 7740.

[0345] One of the limitations of the NC relay/FET solution is that the control of the relay relies on a connection being made in the same connector interface that is being checked for continuity on other pins. Accordingly, various alternative connection integrity circuits are presented, which control the relay using different mechanisms of detecting whether a module is the last/bottom module in the stack.

[0346] In various instances, the bottom module can be detected by a Hall Effect sensor. A magnet is placed on or near a top surface of the functional modules, and a Hall Effect sensor is placed on or near the bottom surface of the functional modules. The Hall Effect sensor of

an upper module will detect the magnet of a lower adjacent module in the stack configuration. Since the bottom module in a stack is not followed by a lower module, its Hall Effect sensor will not detect a magnet. The absence of a magnet indicates the absence of a lower module. Signals from a Hall Effect sensor of a functional module can be analyzed by a control circuit to determine whether the module is the bottom module in the stack.

[0347] In various instances, the bottom module can be detected by any suitable type of near field communication. A tag is placed on or near a top surface of the functional modules, and a tag reader is placed on or near the bottom surface of the functional modules. The tag reader of an upper module will detect the tag of a lower adjacent module in the stack configuration. Since the bottom module in a stack is not followed by a lower module, its tag reader will not detect a tag. The absence of a tag indicates the absence of a lower module. Signals from a tag reader of a functional module can be analyzed by a control circuit to determine whether the module is the bottom module in the stack.

[0348] In various instances, a mechanical switch in the upper module can be tripped by a feature in the lower module. Accordingly, an un-tripped switch is indicative of the last/bottom module in the stack.

[0349] In various instances, an optical sensor in the upper module can be tripped by a feature in a lower module. Accordingly, an un-tripped optical sensor is indicative of the last/bottom module in the stack.

[0350] *Examples*

[0351] Various aspects of the subject matter described herein are set out in the following numbered examples:

[0352] Example 1 - A modular surgical system is disclosed. The modular surgical system comprises a header module, a first surgical module, a second surgical module, and a module identification circuit. The second surgical module is arrangeable in a stack configuration with the header module and the first surgical module. The module identification circuit is configured to cause a pre-determined current to be transmitted to the first surgical module through the second surgical module in the stack configuration, detect a first voltage indicative of a first position of the first surgical module in the stack configuration, and detect a second voltage indicative of a second position of the second surgical module in the stack configuration. The second voltage is different than the first voltage.

[0353] Example 2 - The modular surgical system of Example 1, wherein the second voltage is greater than the first voltage.

[0354] Example 3 - The modular surgical system of any one of Examples 1 and 2, wherein the second surgical module is located further away from the header module within the stack configuration than the first surgical module.

[0355] Example 4 - The modular surgical system of any one of Examples 1-3, further comprising a display, wherein the first position of the first surgical module and the second position of the second surgical module are visually represented on the display.

[0356] Example 5 - The modular surgical system of any one of Examples 1-5, wherein the module identification circuit comprises an operational amplifier and an analog to digital converter to detect the first voltage difference and the second voltage difference.

[0357] Example 6 - A modular surgical system is disclosed. The modular surgical system comprises a header module, a first surgical module located at a first position with respect to the header module, and a second surgical module located at a second position with respect to the header module. The modular surgical system further comprises a module identification circuit configured to detect the presence of the first surgical module and the second surgical module, determine the first position of the first surgical module, and determine the second position of the second surgical module.

[0358] Example 7 - The modular surgical system of Example 6, wherein the module identification circuit is configured to determine the first position and the second position by: causing a pre-determined current to be transmitted to the first surgical module through the second surgical module, detecting a first voltage drop between a current source and a resistor of the first surgical module, and detecting a second voltage drop between the current source and a resistor of the second surgical module, wherein the second voltage drop is less than the first voltage drop.

[0359] Example 8 - The modular surgical system of any one of Examples 6 and 7, wherein the second surgical module is located further from the header module than the first surgical module.

[0360] Example 9 - The modular surgical system of any one of Examples 7 and 8, further comprising a third surgical module located at a third position with respect to the header module, wherein the module identification circuit is configured to determine the third position by causing the pre-determined current to be transmitted to the second surgical module through the third surgical module and detecting a third voltage drop between the current source and a resistor of the third surgical module. The third voltage drop is less than the second voltage drop, and the third surgical module is located further from the header module than the second surgical module.

[0361] Example 10 - The modular surgical system of any one of Examples 6-9, wherein the header module, the first surgical module, and the second surgical module are arranged in a stack configuration.

[0362] Example 11 - The modular surgical system of Example 10, further comprising a display, wherein the stack configuration is visually represented on the display.

[0363] Example 12 - The modular surgical system of any one of Examples 10 and 11, wherein the first position represents a physical location of the first surgical module in the stack configuration, and wherein the second position represents a physical location of the second surgical module in the stack configuration.

[0364] Example 13 - The modular surgical system of Example 12, further comprising a display, wherein the physical location of the first surgical module and the physical location of the second surgical module within the stack configuration is visually represented on the display.

[0365] Example 14 - The modular surgical system of any one of Examples 6-13, further comprising a connection integrity circuit, wherein the connection integrity circuit is configured to assess the integrity of a connection between the first surgical module and the second surgical module.

[0366] Example 15 - A modular surgical system is disclosed. The modular surgical system comprises a header module, a first surgical module, and a second surgical module, wherein the header module, the first surgical module, and the second surgical module are arranged in a stack configuration. The modular surgical system further comprises a module identification circuit configured to detect the presence of the first surgical module and the second surgical module, determine a first position of the first surgical module within the stack configuration, and determine a second position of the second surgical module within the stack configuration, wherein the second position is different than the first position.

[0367] Example 16 - The modular surgical system of Example 15, wherein the module identification circuit is configured to determine the first position and the second position by causing a pre-determined current to be transmitted through the second surgical module to the first surgical module, measuring a second voltage differential between a current source of the header module and the second surgical module, and measuring a first voltage differential between the current source and the first surgical module, wherein the first voltage differential is greater than the second voltage differential.

[0368] Example 17 - The modular surgical system of any one of Examples 15 and 16, wherein the first surgical module is located closer to the header module in the stack configuration than the second surgical module.

[0369] Example 18 - The modular surgical system of any one of Examples 16 and 17, wherein the module identification circuit is configured to assign a first address to the first surgical module based on the first measured voltage differential, and wherein the module identification circuit is configured to assign a second address to the second surgical module based on the second measured voltage differential.

[0370] Example 19 - The modular surgical system of any one of Examples 15-18, further comprising a display, wherein the determined positions of the first surgical module and the

second surgical module within the stack configuration are visually represented on the display.

[0371] Example 20 - The modular surgical system of any one of Examples 15-19, further comprising a connection integrity circuit, wherein the connection integrity circuit is configured to confirm a connection between the first surgical module and the second surgical module.

[0372] While several forms have been illustrated and described, it is not the intention of Applicant to restrict or limit the scope of the appended claims to such detail. Numerous modifications, variations, changes, substitutions, combinations, and equivalents to those forms may be implemented and will occur to those skilled in the art without departing from the scope of the present disclosure. Moreover, the structure of each element associated with the described forms can be alternatively described as a means for providing the function performed by the element. Also, where materials are disclosed for certain components, other materials may be used. It is therefore to be understood that the foregoing description and the appended claims are intended to cover all such modifications, combinations, and variations as falling within the scope of the disclosed forms. The appended claims are intended to cover all such modifications, variations, changes, substitutions, modifications, and equivalents.

[0373] The foregoing detailed description has set forth various forms of the devices and/or processes via the use of block diagrams, flowcharts, and/or examples. Insofar as such block diagrams, flowcharts, and/or examples contain one or more functions and/or operations, it will be understood by those within the art that each function and/or operation within such block diagrams, flowcharts, and/or examples can be implemented, individually and/or collectively, by a wide range of hardware, software, firmware, or virtually any combination thereof. Those skilled in the art will recognize that some aspects of the forms disclosed herein, in whole or in part, can be equivalently implemented in integrated circuits, as one or more computer programs running on one or more computers (e.g., as one or more programs running on one or more computer systems), as one or more programs running on one or more processors (e.g., as one or more programs running on one or more microprocessors), as firmware, or as virtually any combination thereof, and that designing the circuitry and/or writing the code for the software and or firmware would be well within the skill of one of skill in the art in light of this disclosure. In addition, those skilled in the art will appreciate that the mechanisms of the subject matter described herein are capable of being distributed as one or more program products in a variety of forms, and that an illustrative form of the subject matter described herein applies regardless of the particular type of signal bearing medium used to actually carry out the distribution.

[0374] Instructions used to program logic to perform various disclosed aspects can be stored within a memory in the system, such as dynamic random access memory (DRAM),

cache, flash memory, or other storage. Furthermore, the instructions can be distributed via a network or by way of other computer readable media. Thus a machine-readable medium may include any mechanism for storing or transmitting information in a form readable by a machine (e.g., a computer), but is not limited to, floppy diskettes, optical disks, compact disc, read-only memory (CD-ROMs), and magneto-optical disks, read-only memory (ROMs), random access memory (RAM), erasable programmable read-only memory (EPROM), electrically erasable programmable read-only memory (EEPROM), magnetic or optical cards, flash memory, or a tangible, machine-readable storage used in the transmission of information over the Internet via electrical, optical, acoustical or other forms of propagated signals (e.g., carrier waves, infrared signals, digital signals, etc.). Accordingly, the non-transitory computer-readable medium includes any type of tangible machine-readable medium suitable for storing or transmitting electronic instructions or information in a form readable by a machine (e.g., a computer).

[0375] As used in any aspect herein, the term “control circuit” may refer to, for example, hardwired circuitry, programmable circuitry (e.g., a computer processor including one or more individual instruction processing cores, processing unit, processor, microcontroller, microcontroller unit, controller, digital signal processor (DSP), programmable logic device (PLD), programmable logic array (PLA), or field programmable gate array (FPGA)), state machine circuitry, firmware that stores instructions executed by programmable circuitry, and any combination thereof. The control circuit may, collectively or individually, be embodied as circuitry that forms part of a larger system, for example, an integrated circuit (IC), an application-specific integrated circuit (ASIC), a system on-chip (SoC), desktop computers, laptop computers, tablet computers, servers, smart phones, etc. Accordingly, as used herein “control circuit” includes, but is not limited to, electrical circuitry having at least one discrete electrical circuit, electrical circuitry having at least one integrated circuit, electrical circuitry having at least one application specific integrated circuit, electrical circuitry forming a general purpose computing device configured by a computer program (e.g., a general purpose computer configured by a computer program which at least partially carries out processes and/or devices described herein, or a microprocessor configured by a computer program which at least partially carries out processes and/or devices described herein), electrical circuitry forming a memory device (e.g., forms of random access memory), and/or electrical circuitry forming a communications device (e.g., a modem, communications switch, or optical-electrical equipment). Those having skill in the art will recognize that the subject matter described herein may be implemented in an analog or digital fashion or some combination thereof.

[0376] As used in any aspect herein, the term “logic” may refer to an app, software, firmware and/or circuitry configured to perform any of the aforementioned operations.

Software may be embodied as a software package, code, instructions, instruction sets and/or data recorded on non-transitory computer readable storage medium. Firmware may be embodied as code, instructions or instruction sets and/or data that are hard-coded (e.g., nonvolatile) in memory devices.

[0377] As used in any aspect herein, the terms “component,” “system,” “module” and the like can refer to a computer-related entity, either hardware, a combination of hardware and software, software, or software in execution.

[0378] As used in any aspect herein, an “algorithm” refers to a self-consistent sequence of steps leading to a desired result, where a “step” refers to a manipulation of physical quantities and/or logic states which may, though need not necessarily, take the form of electrical or magnetic signals capable of being stored, transferred, combined, compared, and otherwise manipulated. It is common usage to refer to these signals as bits, values, elements, symbols, characters, terms, numbers, or the like. These and similar terms may be associated with the appropriate physical quantities and are merely convenient labels applied to these quantities and/or states.

[0379] A network may include a packet switched network. The communication devices may be capable of communicating with each other using a selected packet switched network communications protocol. One example communications protocol may include an Ethernet communications protocol which may be capable permitting communication using a Transmission Control Protocol/Internet Protocol (TCP/IP). The Ethernet protocol may comply or be compatible with the Ethernet standard published by the Institute of Electrical and Electronics Engineers (IEEE) titled “IEEE 802.3 Standard”, published in December, 2008 and/or later versions of this standard. Alternatively or additionally, the communication devices may be capable of communicating with each other using an X.25 communications protocol. The X.25 communications protocol may comply or be compatible with a standard promulgated by the International Telecommunication Union-Telecommunication Standardization Sector (ITU-T). Alternatively or additionally, the communication devices may be capable of communicating with each other using a frame relay communications protocol. The frame relay communications protocol may comply or be compatible with a standard promulgated by Consultative Committee for International Telegraph and Telephone (CCITT) and/or the American National Standards Institute (ANSI). Alternatively or additionally, the transceivers may be capable of communicating with each other using an Asynchronous Transfer Mode (ATM) communications protocol. The ATM communications protocol may comply or be compatible with an ATM standard published by the ATM Forum titled “ATM-MPLS Network Interworking 2.0” published August 2001, and/or later versions of this standard. Of course, different and/or after-developed connection-oriented network communication protocols are equally contemplated herein.

[0380] Unless specifically stated otherwise as apparent from the foregoing disclosure, it is appreciated that, throughout the foregoing disclosure, discussions using terms such as “processing,” “computing,” “calculating,” “determining,” “displaying,” or the like, refer to the action and processes of a computer system, or similar electronic computing device, that manipulates and transforms data represented as physical (electronic) quantities within the computer system's registers and memories into other data similarly represented as physical quantities within the computer system memories or registers or other such information storage, transmission or display devices.

[0381] One or more components may be referred to herein as “configured to,” “configurable to,” “operable/operative to,” “adapted/adaptable,” “able to,” “conformable/conformed to,” etc. Those skilled in the art will recognize that “configured to” can generally encompass active-state components and/or inactive-state components and/or standby-state components, unless context requires otherwise.

[0382] The terms “proximal” and “distal” are used herein with reference to a clinician manipulating the handle portion of the surgical instrument. The term “proximal” refers to the portion closest to the clinician and the term “distal” refers to the portion located away from the clinician. It will be further appreciated that, for convenience and clarity, spatial terms such as “vertical,” “horizontal,” “up,” and “down” may be used herein with respect to the drawings. However, surgical instruments are used in many orientations and positions, and these terms are not intended to be limiting and/or absolute.

[0383] Those skilled in the art will recognize that, in general, terms used herein, and especially in the appended claims (e.g., bodies of the appended claims) are generally intended as “open” terms (e.g., the term “including” should be interpreted as “including but not limited to,” the term “having” should be interpreted as “having at least,” the term “includes” should be interpreted as “includes but is not limited to,” etc.). It will be further understood by those within the art that if a specific number of an introduced claim recitation is intended, such an intent will be explicitly recited in the claim, and in the absence of such recitation no such intent is present. For example, as an aid to understanding, the following appended claims may contain usage of the introductory phrases “at least one” and “one or more” to introduce claim recitations. However, the use of such phrases should not be construed to imply that the introduction of a claim recitation by the indefinite articles “a” or “an” limits any particular claim containing such introduced claim recitation to claims containing only one such recitation, even when the same claim includes the introductory phrases “one or more” or “at least one” and indefinite articles such as “a” or “an” (e.g., “a” and/or “an” should typically be interpreted to mean “at least one” or “one or more”); the same holds true for the use of definite articles used to introduce claim recitations.

[0384] In addition, even if a specific number of an introduced claim recitation is explicitly recited, those skilled in the art will recognize that such recitation should typically be interpreted to mean at least the recited number (e.g., the bare recitation of “two recitations,” without other modifiers, typically means at least two recitations, or two or more recitations). Furthermore, in those instances where a convention analogous to “at least one of A, B, and C, etc.” is used, in general such a construction is intended in the sense one having skill in the art would understand the convention (e.g., “a system having at least one of A, B, and C” would include but not be limited to systems that have A alone, B alone, C alone, A and B together, A and C together, B and C together, and/or A, B, and C together, etc.). In those instances where a convention analogous to “at least one of A, B, or C, etc.” is used, in general such a construction is intended in the sense one having skill in the art would understand the convention (e.g., “a system having at least one of A, B, or C” would include but not be limited to systems that have A alone, B alone, C alone, A and B together, A and C together, B and C together, and/or A, B, and C together, etc.). It will be further understood by those within the art that typically a disjunctive word and/or phrase presenting two or more alternative terms, whether in the description, claims, or drawings, should be understood to contemplate the possibilities of including one of the terms, either of the terms, or both terms unless context dictates otherwise. For example, the phrase “A or B” will be typically understood to include the possibilities of “A” or “B” or “A and B.”

[0385] With respect to the appended claims, those skilled in the art will appreciate that recited operations therein may generally be performed in any order. Also, although various operational flow diagrams are presented in a sequence(s), it should be understood that the various operations may be performed in other orders than those which are illustrated, or may be performed concurrently. Examples of such alternate orderings may include overlapping, interleaved, interrupted, reordered, incremental, preparatory, supplemental, simultaneous, reverse, or other variant orderings, unless context dictates otherwise. Furthermore, terms like “responsive to,” “related to,” or other past-tense adjectives are generally not intended to exclude such variants, unless context dictates otherwise.

[0386] It is worthy to note that any reference to “one aspect,” “an aspect,” “an exemplification,” “one exemplification,” and the like means that a particular feature, structure, or characteristic described in connection with the aspect is included in at least one aspect. Thus, appearances of the phrases “in one aspect,” “in an aspect,” “in an exemplification,” and “in one exemplification” in various places throughout the specification are not necessarily all referring to the same aspect. Furthermore, the particular features, structures or characteristics may be combined in any suitable manner in one or more aspects.

[0387] Any patent application, patent, non-patent publication, or other disclosure material referred to in this specification and/or listed in any Application Data Sheet is incorporated by

reference herein, to the extent that the incorporated materials is not inconsistent herewith. As such, and to the extent necessary, the disclosure as explicitly set forth herein supersedes any conflicting material incorporated herein by reference. Any material, or portion thereof, that is said to be incorporated by reference herein, but which conflicts with existing definitions, statements, or other disclosure material set forth herein will only be incorporated to the extent that no conflict arises between that incorporated material and the existing disclosure material.

[0388] In summary, numerous benefits have been described which result from employing the concepts described herein. The foregoing description of the one or more forms has been presented for purposes of illustration and description. It is not intended to be exhaustive or limiting to the precise form disclosed. Modifications or variations are possible in light of the above teachings. The one or more forms were chosen and described in order to illustrate principles and practical application to thereby enable one of ordinary skill in the art to utilize the various forms and with various modifications as are suited to the particular use contemplated. It is intended that the claims submitted herewith define the overall scope.

CLAIMS

WHAT IS CLAIMED IS:

1. A modular surgical system, comprising:
 - a header module;
 - a first surgical module;
 - a second surgical module arrangeable in a stack configuration with the header module and the first surgical module; and
 - a module identification circuit configured to:
 - cause a pre-determined current to be transmitted to the first surgical module through the second surgical module in the stack configuration;
 - detect a first voltage indicative of a first position of the first surgical module in the stack configuration; and
 - detect a second voltage indicative of a second position of the second surgical module in the stack configuration, wherein the second voltage is different than the first voltage.
2. The modular surgical system of Claim 1, wherein the second voltage is greater than the first voltage.
3. The modular surgical system of Claim 2, wherein the second surgical module is located further away from the header module within the stack configuration than the first surgical module.
4. The modular surgical system of Claim 1, further comprising a display, wherein the first position of the first surgical module and the second position of the second surgical module are visually represented on the display.
5. The modular surgical system of Claim 1, wherein the module identification circuit comprises an operational amplifier and an analog to digital converter to detect the first voltage difference and the second voltage difference.
6. A modular surgical system, comprising:
 - a header module;
 - a first surgical module located at a first position with respect to the header module;
 - a second surgical module located at a second position with respect to the header module; and

- a module identification circuit configured to:
- detect the presence of the first surgical module and the second surgical module;
 - determine the first position of the first surgical module; and
 - determine the second position of the second surgical module.
7. The modular surgical system of Claim 6, wherein the module identification circuit is configured to determine the first position and the second position by:
- causing a pre-determined current to be transmitted to the first surgical module through the second surgical module;
 - detecting a first voltage drop between a current source and a resistor of the first surgical module; and
 - detecting a second voltage drop between the current source and a resistor of the second surgical module, wherein the second voltage drop is less than the first voltage drop.
8. The modular surgical system of Claim 7, wherein the second surgical module is located further from the header module than the first surgical module.
9. The modular surgical system of Claim 7, further comprising a third surgical module located at a third position with respect to the header module, wherein the module identification circuit is configured to determine the third position by:
- causing the pre-determined current to be transmitted to the second surgical module through the third surgical module; and
 - detecting a third voltage drop between the current source and a resistor of the third surgical module, wherein the third voltage drop is less than the second voltage drop, and wherein the third surgical module is located further from the header module than the second surgical module.
10. The modular surgical system of Claim 6, wherein the header module, the first surgical module, and the second surgical module are arranged in a stack configuration.
11. The modular surgical system of Claim 10, further comprising a display, wherein the stack configuration is visually represented on the display.
12. The modular surgical system of Claim 10, wherein the first position represents a physical location of the first surgical module in the stack configuration, and wherein the

second position represents a physical location of the second surgical module in the stack configuration.

13. The modular surgical system of Claim 12, further comprising a display, wherein the physical location of the first surgical module and the physical location of the second surgical module within the stack configuration is visually represented on the display.

14. The modular surgical system of Claim 6, further comprising a connection integrity circuit, wherein the connection integrity circuit is configured to assess the integrity of a connection between the first surgical module and the second surgical module.

15. A modular surgical system, comprising:

- a header module;

- a first surgical module;

- a second surgical module, wherein the header module, the first surgical module, and the second surgical module are arranged in a stack configuration; and

- a module identification circuit configured to:

- detect the presence of the first surgical module and the second surgical module;

- determine a first position of the first surgical module within the stack configuration; and

- determine a second position of the second surgical module within the stack configuration, wherein the second position is different than the first position.

16. The modular surgical system of Claim 15, wherein the module identification circuit is configured to determine the first position and the second position by:

- causing a pre-determined current to be transmitted through the second surgical module to the first surgical module;

- measuring a second voltage differential between a current source of the header module and the second surgical module; and

- measuring a first voltage differential between the current source and the first surgical module, wherein the first voltage differential is greater than the second voltage differential.

17. The modular surgical system of Claim 16, wherein the first surgical module is located closer to the header module in the stack configuration than the second surgical module.

18. The modular surgical system of Claim 16, wherein the module identification circuit is configured to assign a first address to the first surgical module based on the first measured voltage differential, and wherein the module identification circuit is configured to assign a second address to the second surgical module based on the second measured voltage differential.

19. The modular surgical system of Claim 15, further comprising a display, wherein the determined positions of the first surgical module and the second surgical module within the stack configuration are visually represented on the display.

20. The modular surgical system of Claim 15, further comprising a connection integrity circuit, wherein the connection integrity circuit is configured to confirm a connection between the first surgical module and the second surgical module.

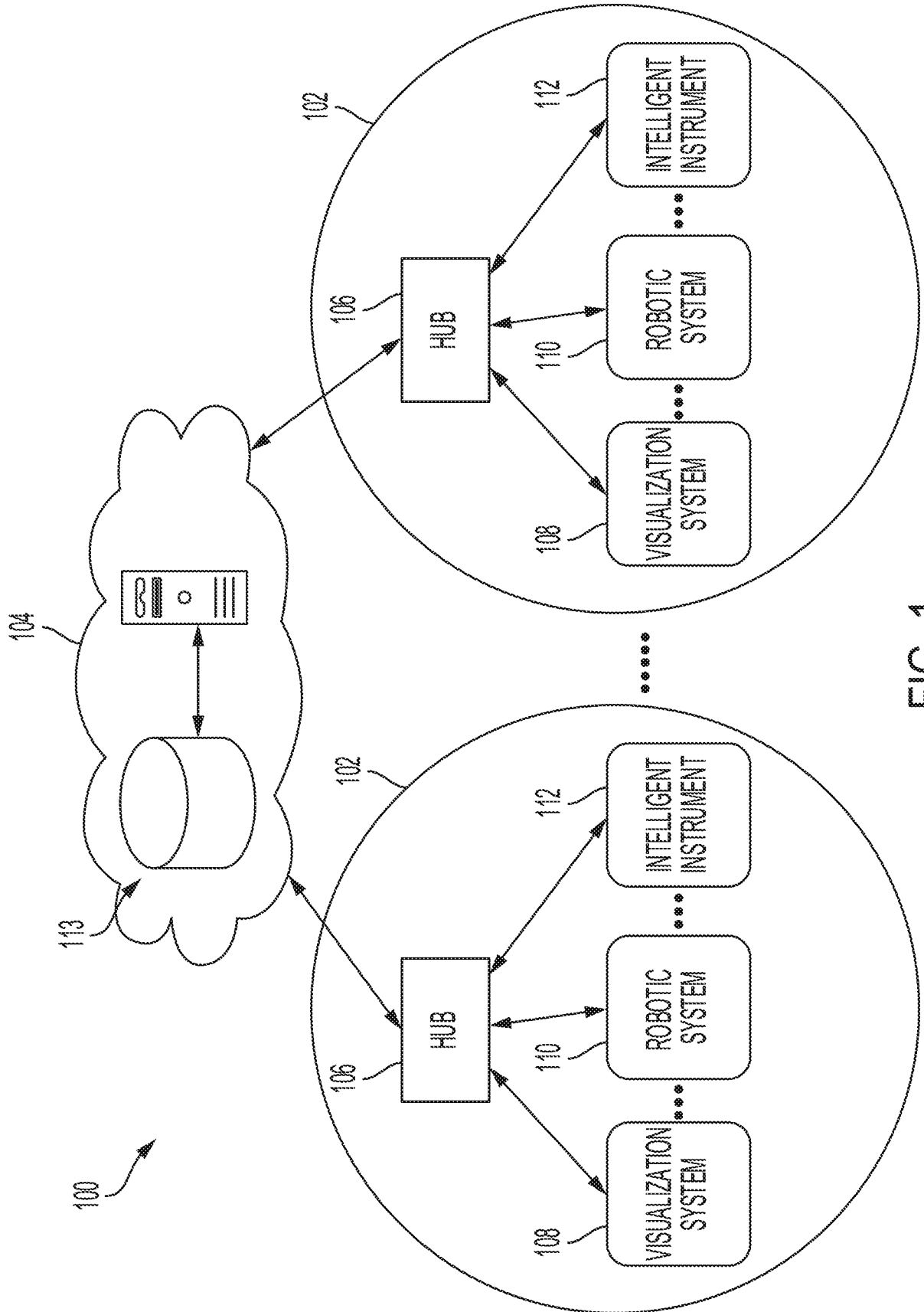
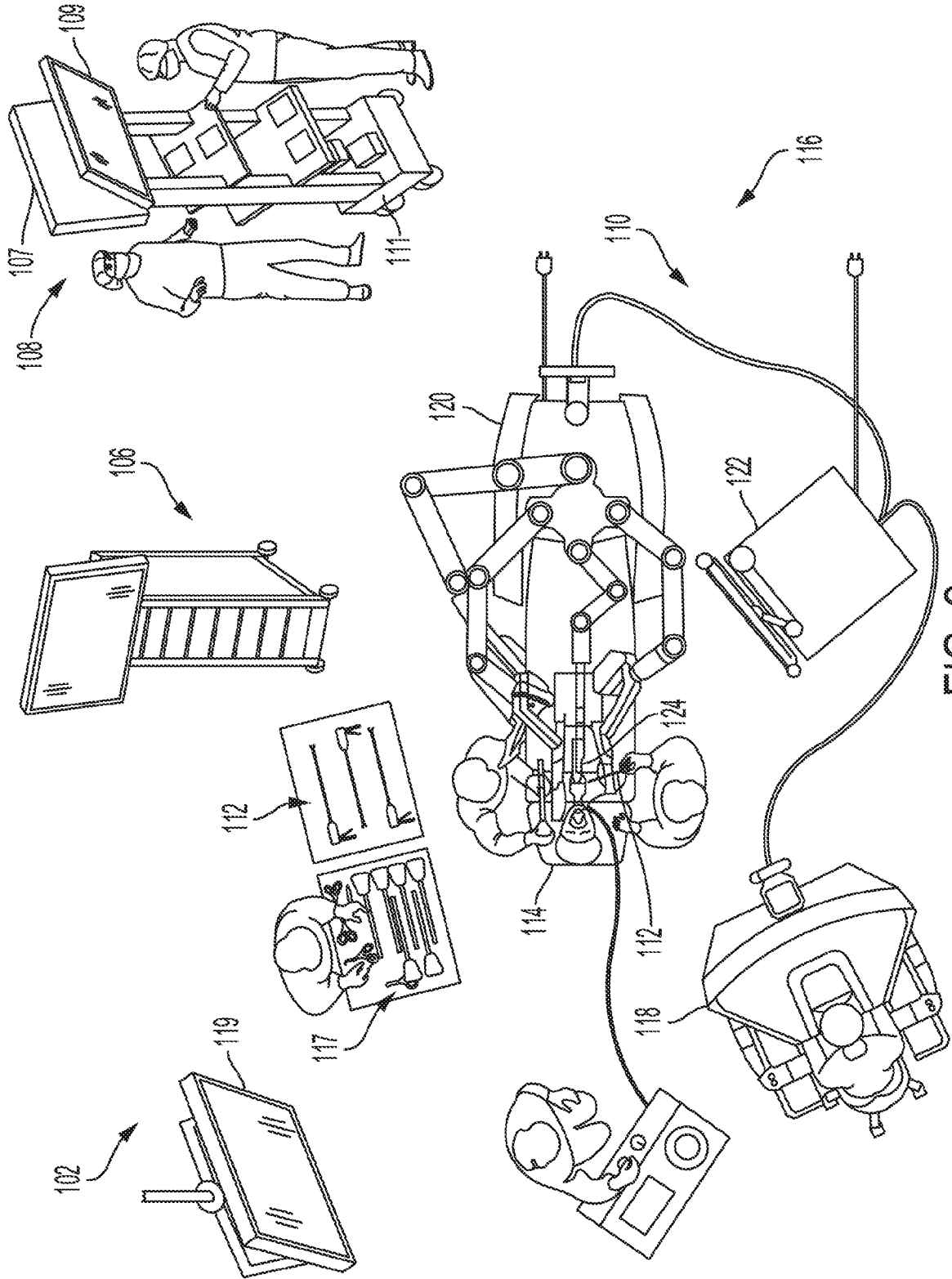

FIG. 1



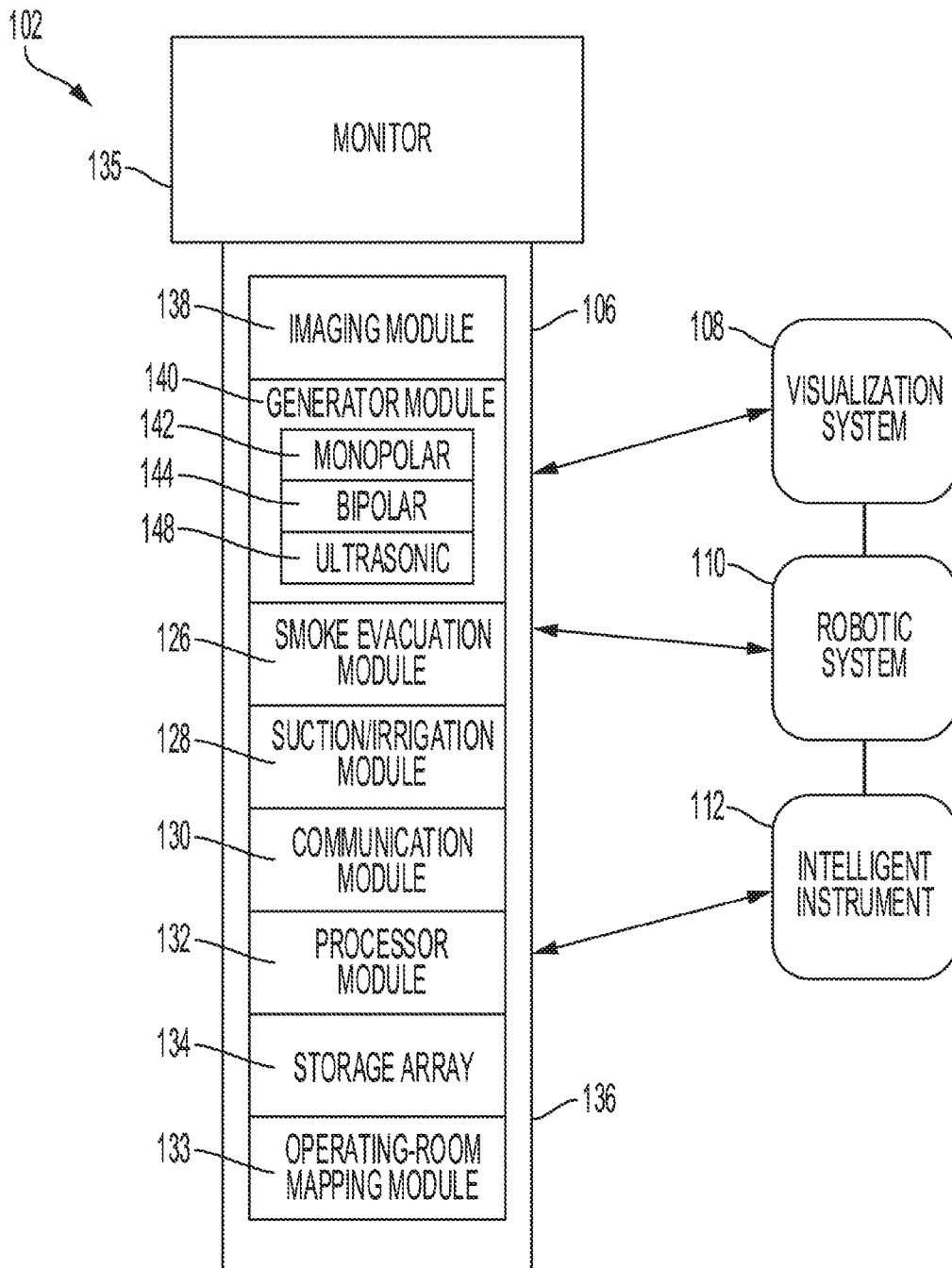

FIG. 3

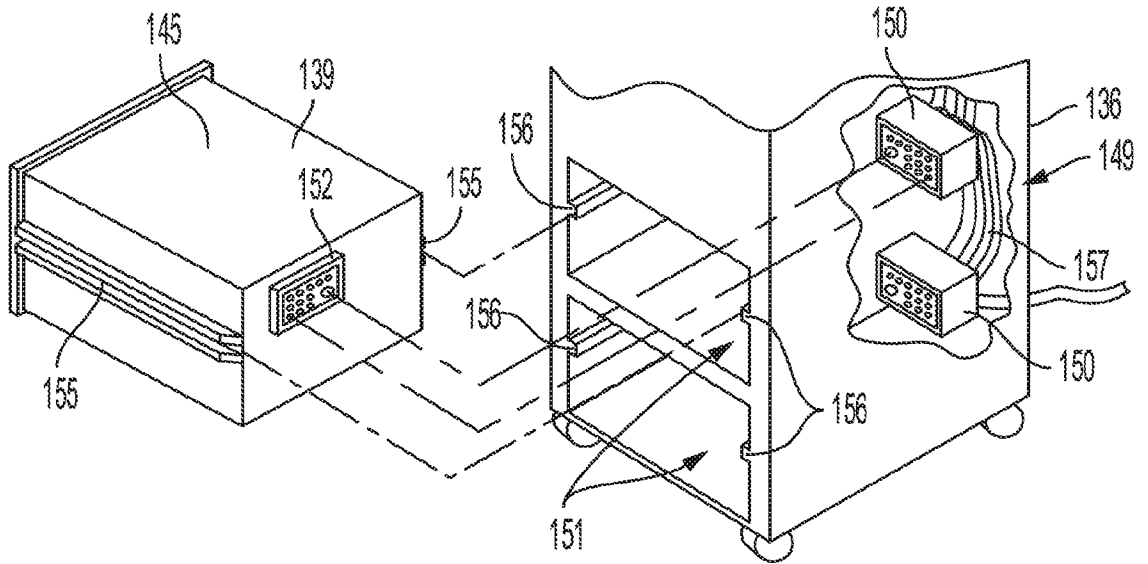

FIG. 4

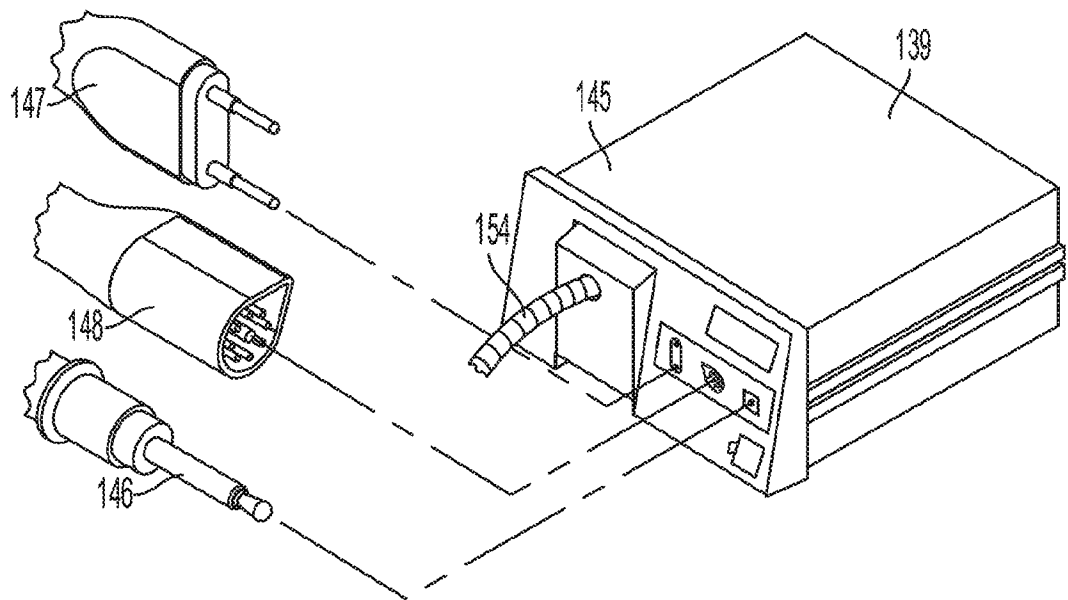

FIG. 5

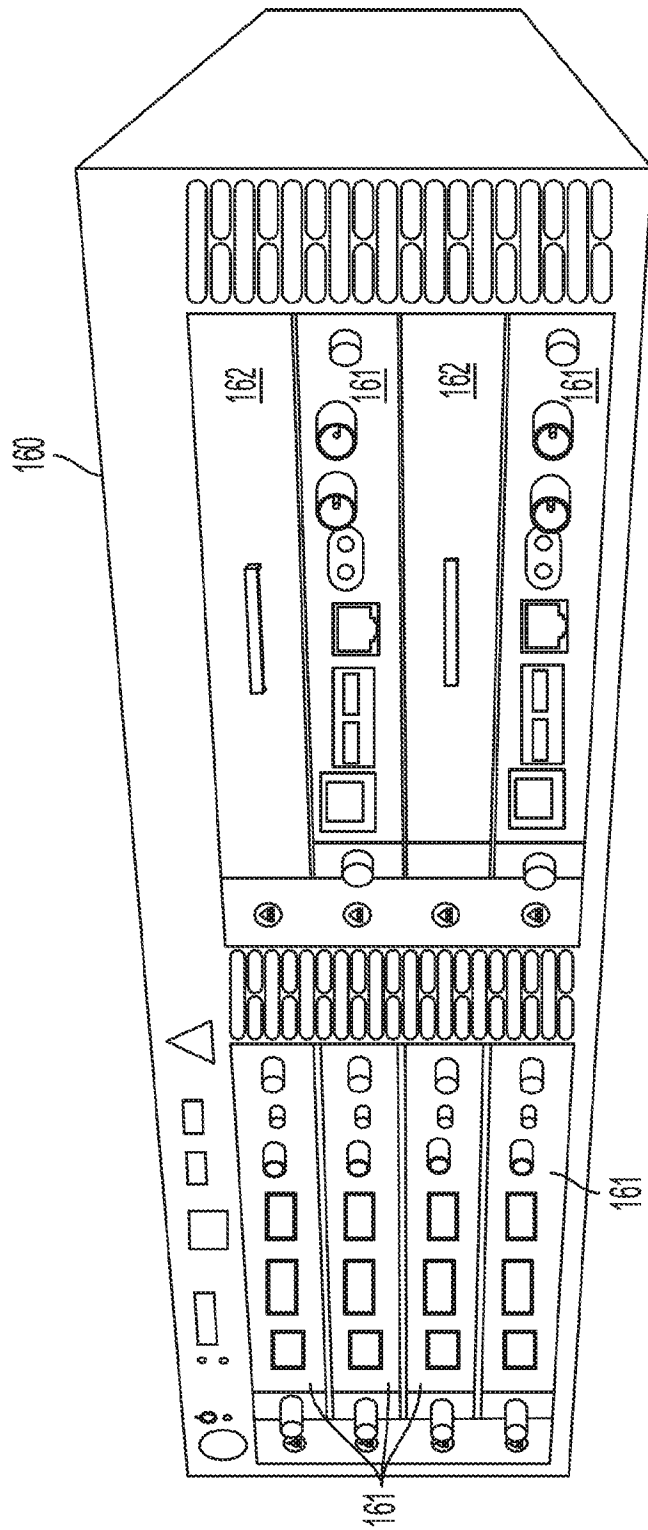

FIG. 6

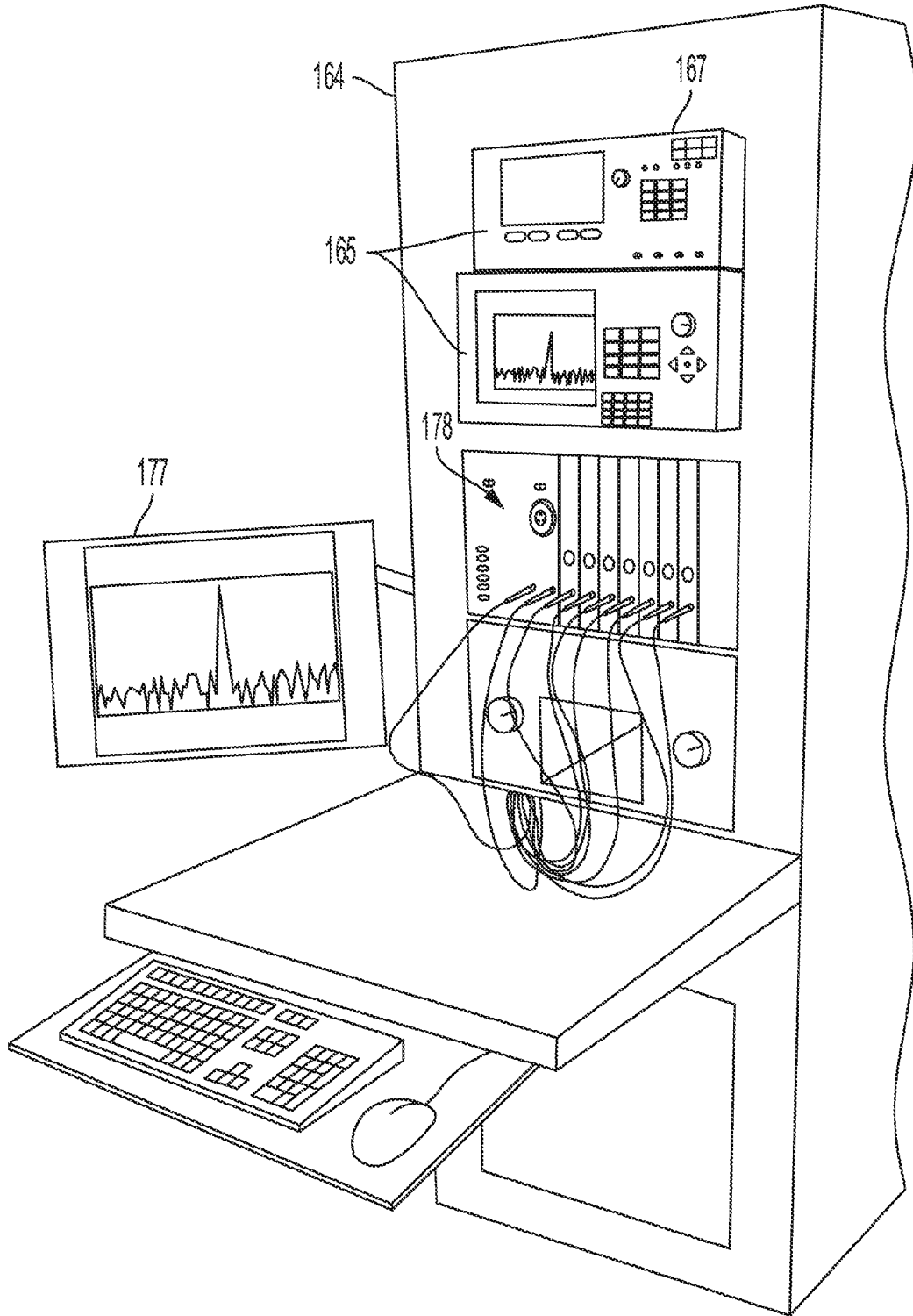

FIG. 7

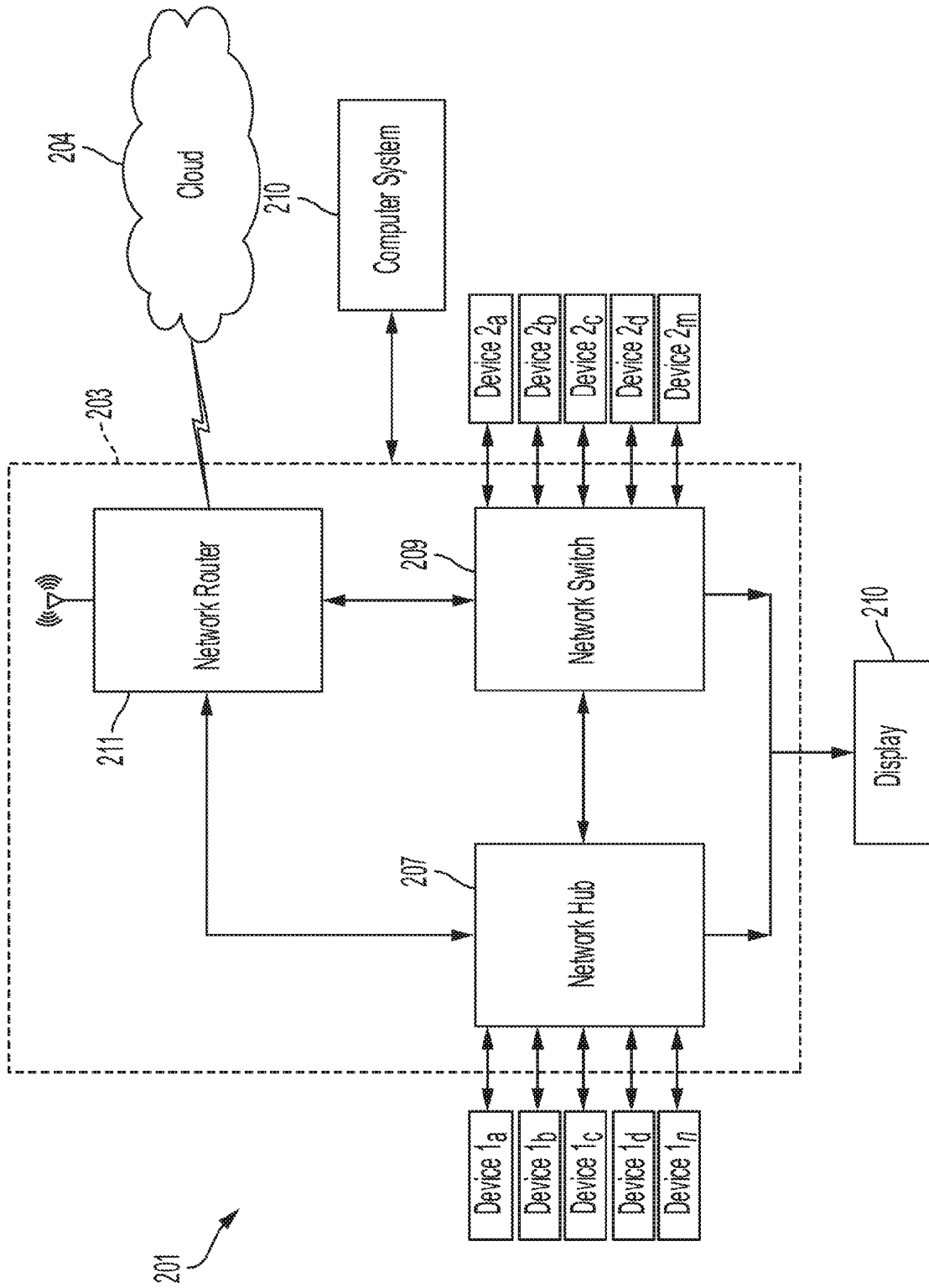

FIG. 8

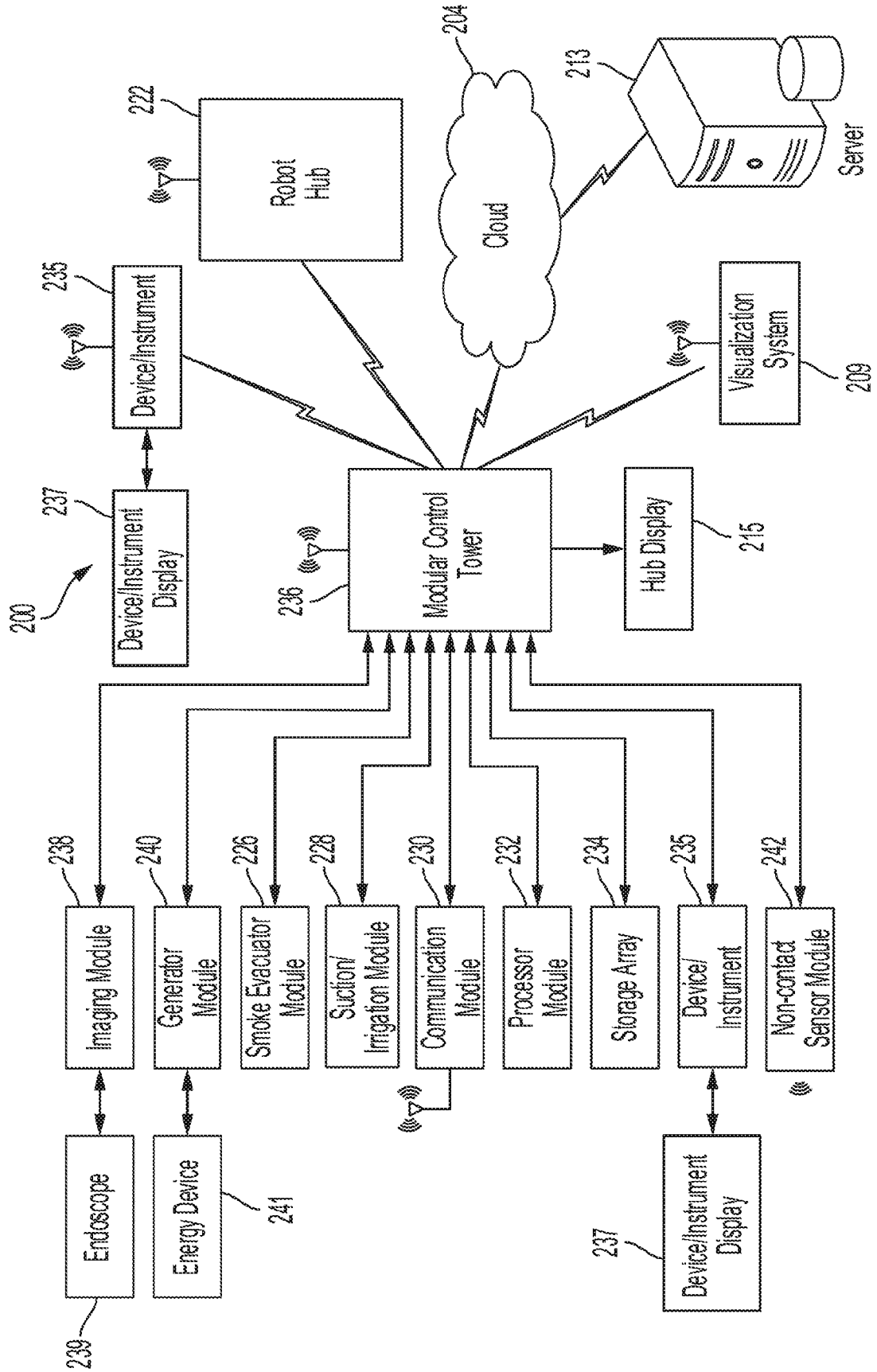

FIG. 9

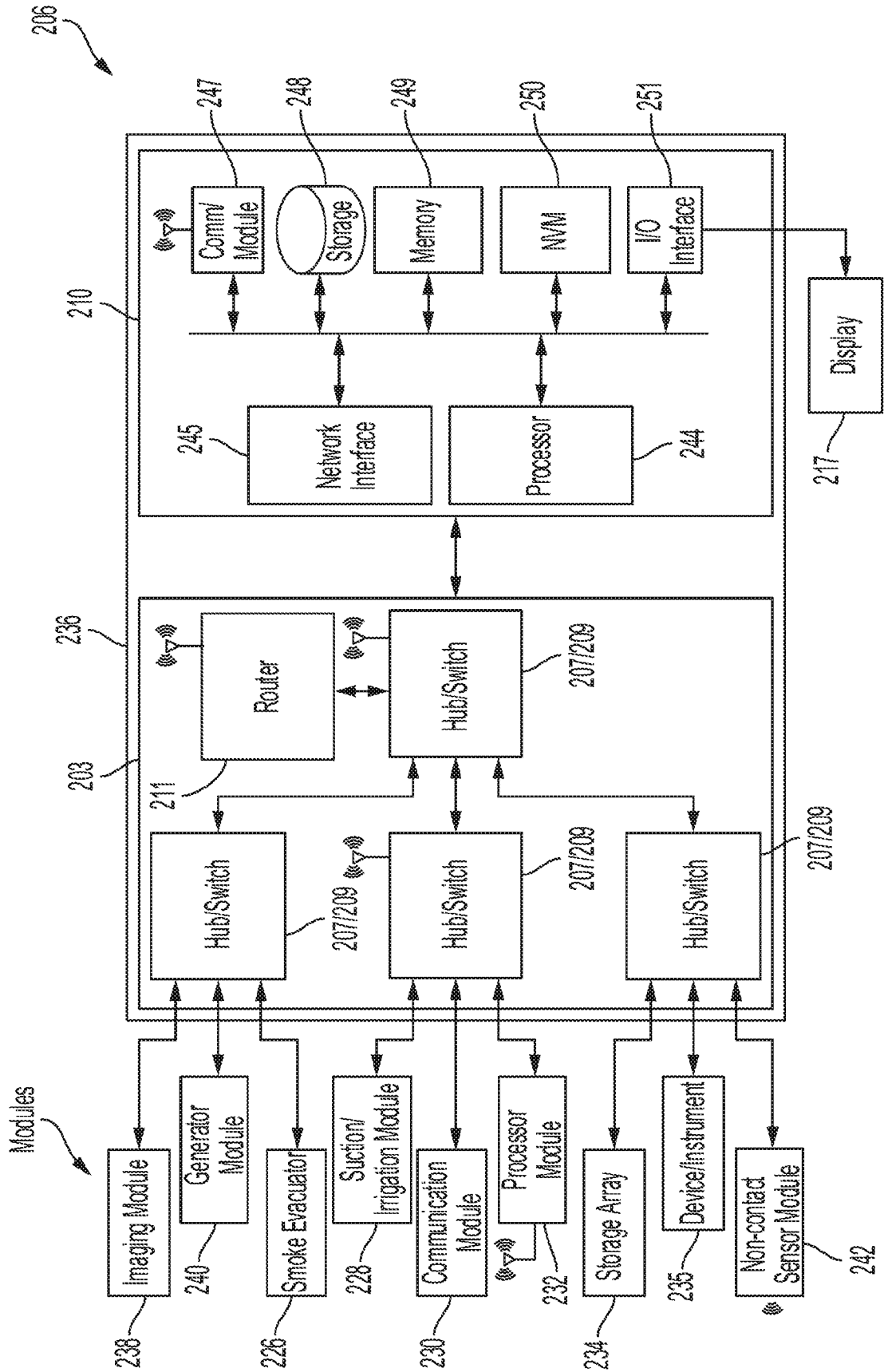

FIG. 10

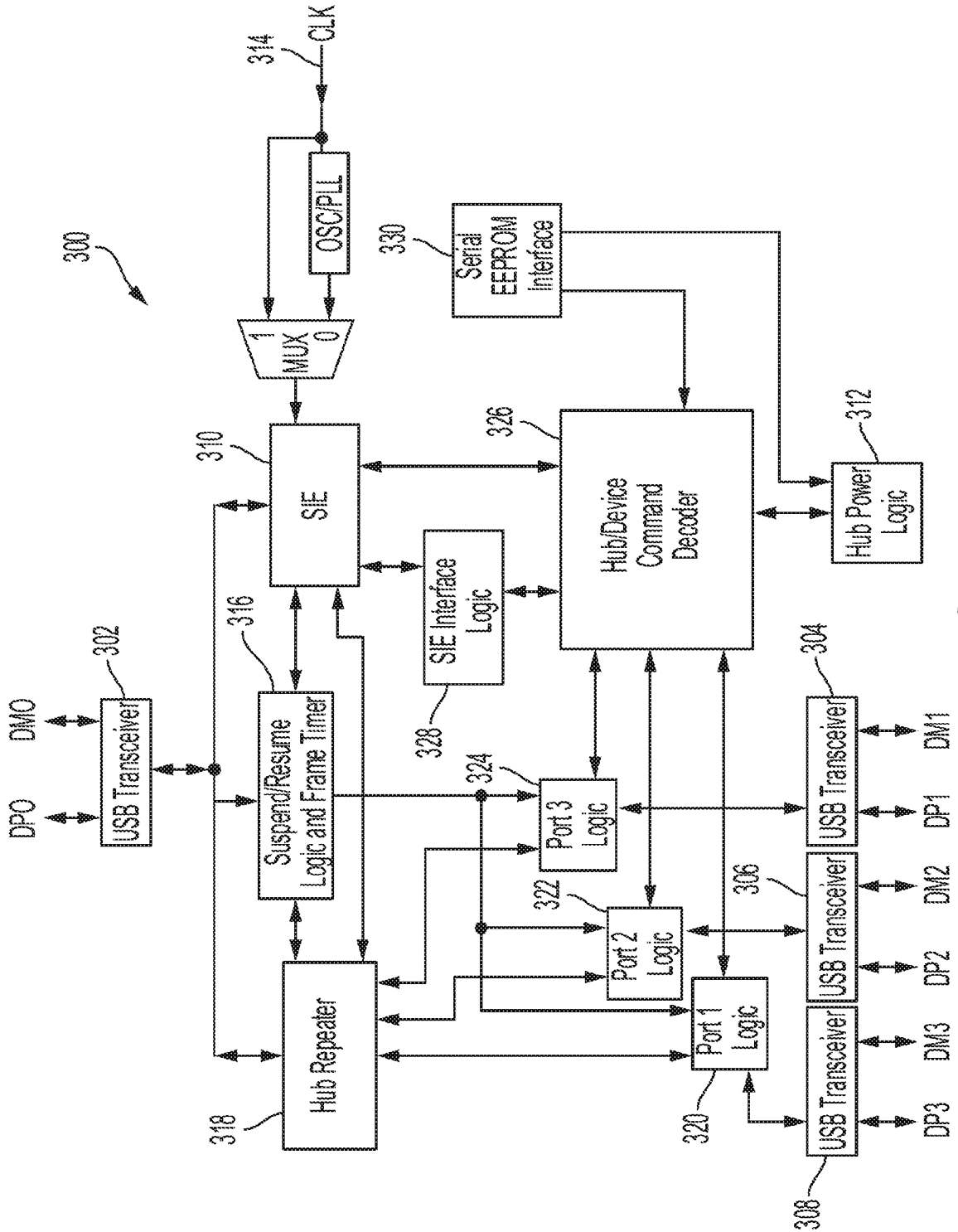

FIG. 11

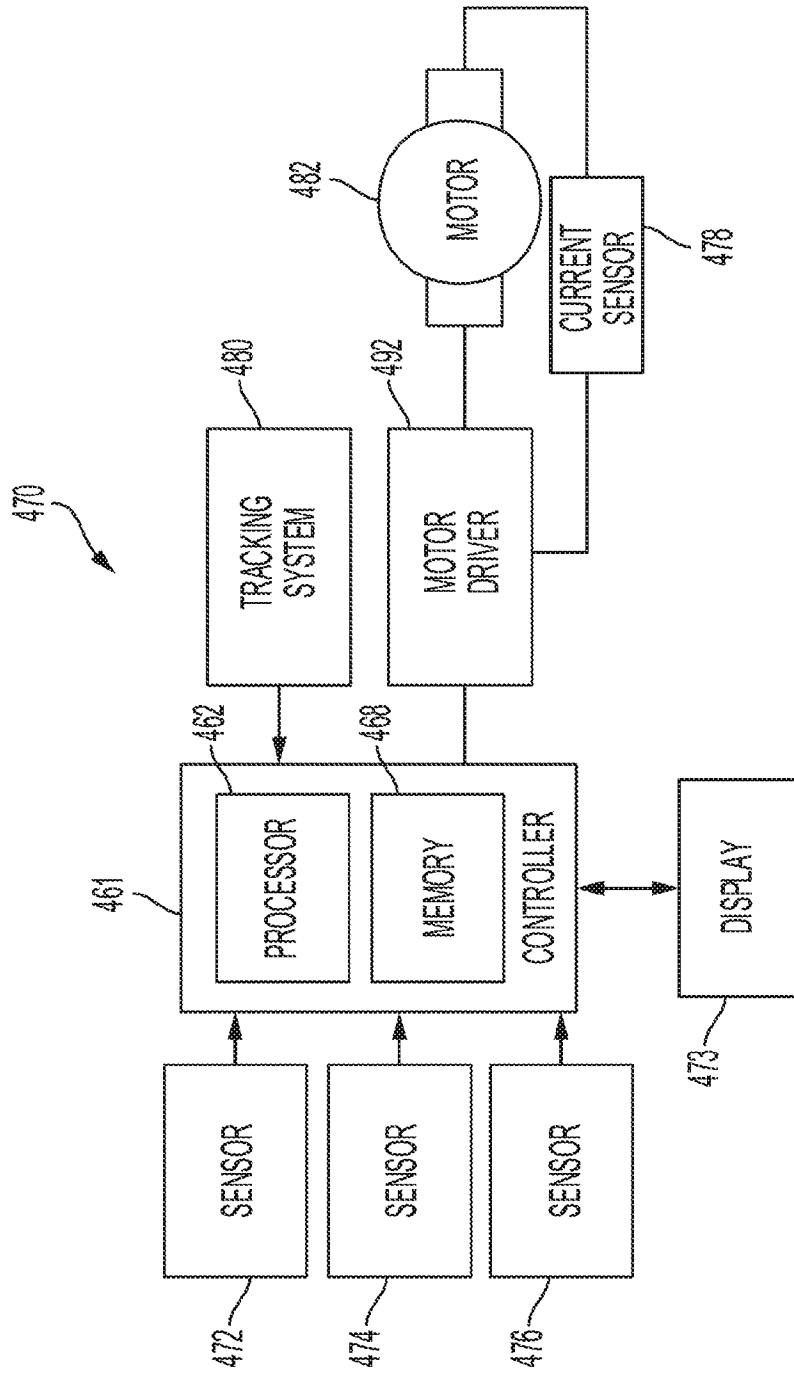

FIG. 12

12/40

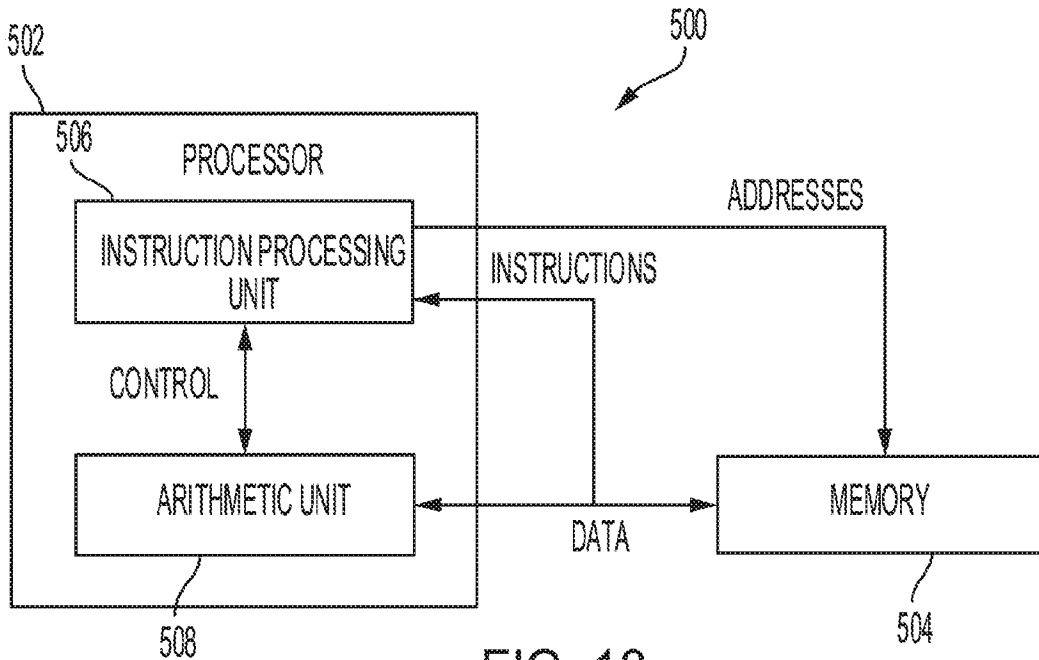

FIG. 13

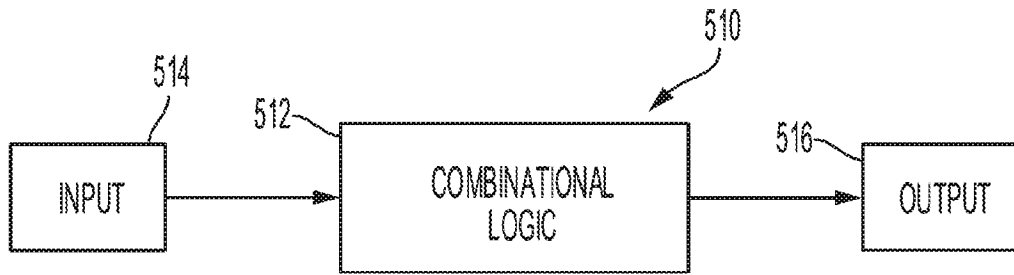

FIG. 14

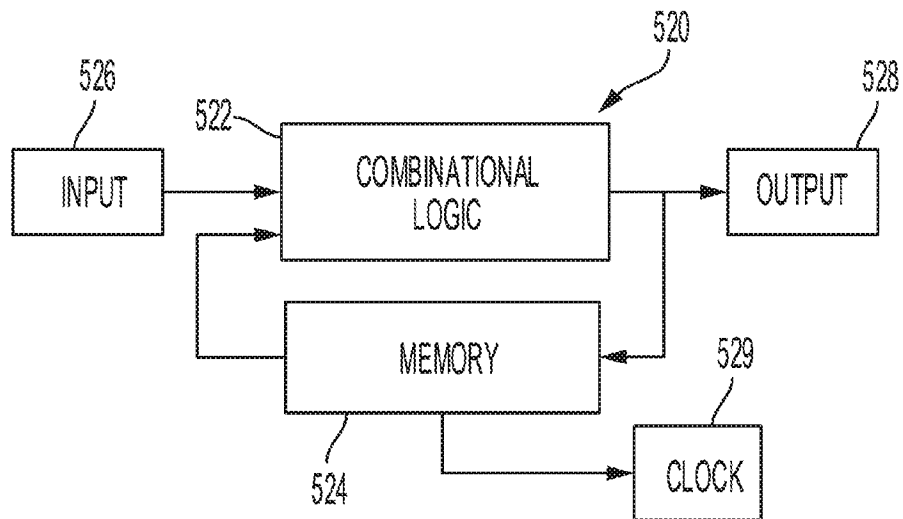

FIG. 15

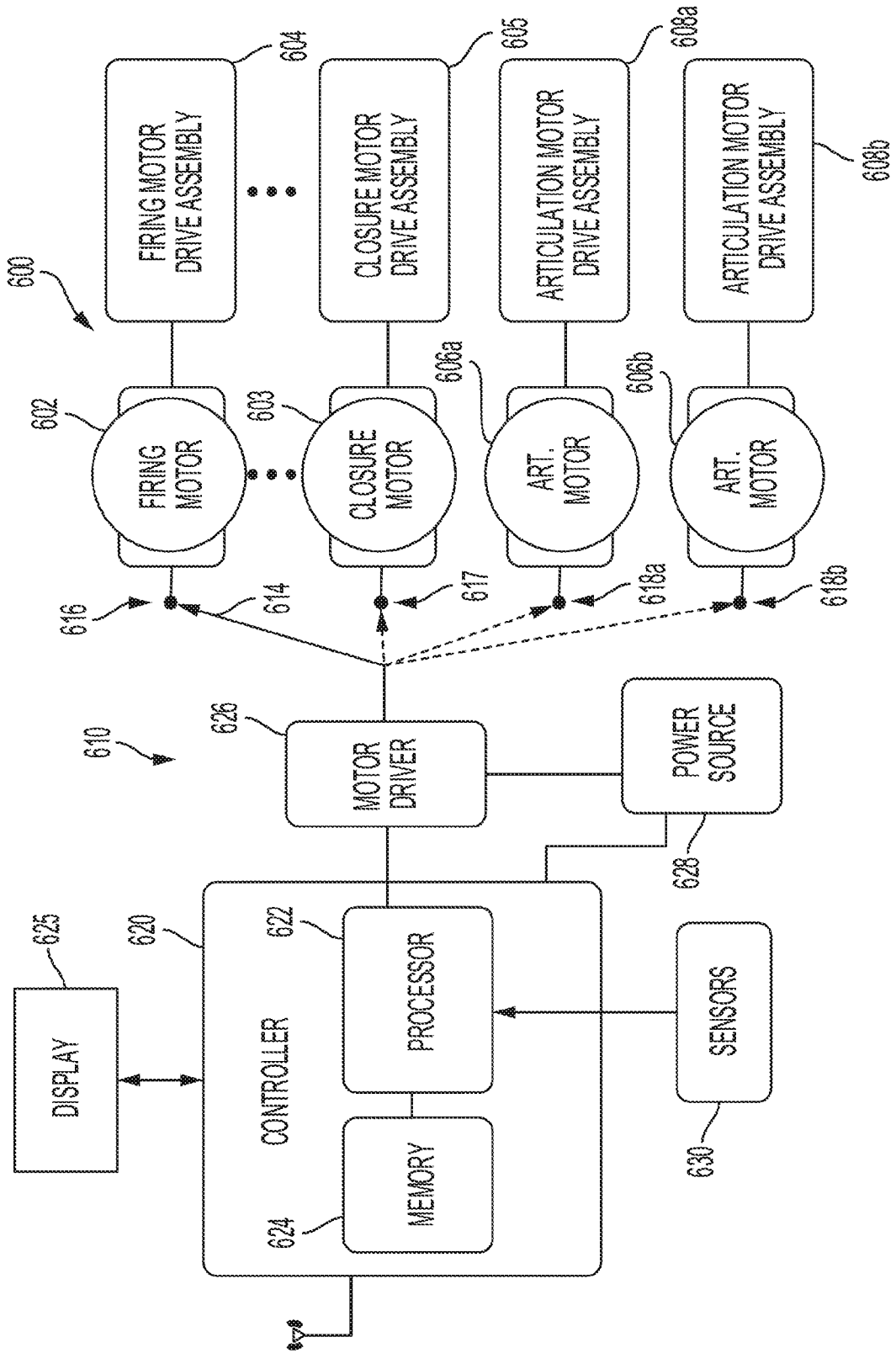

FIG. 16

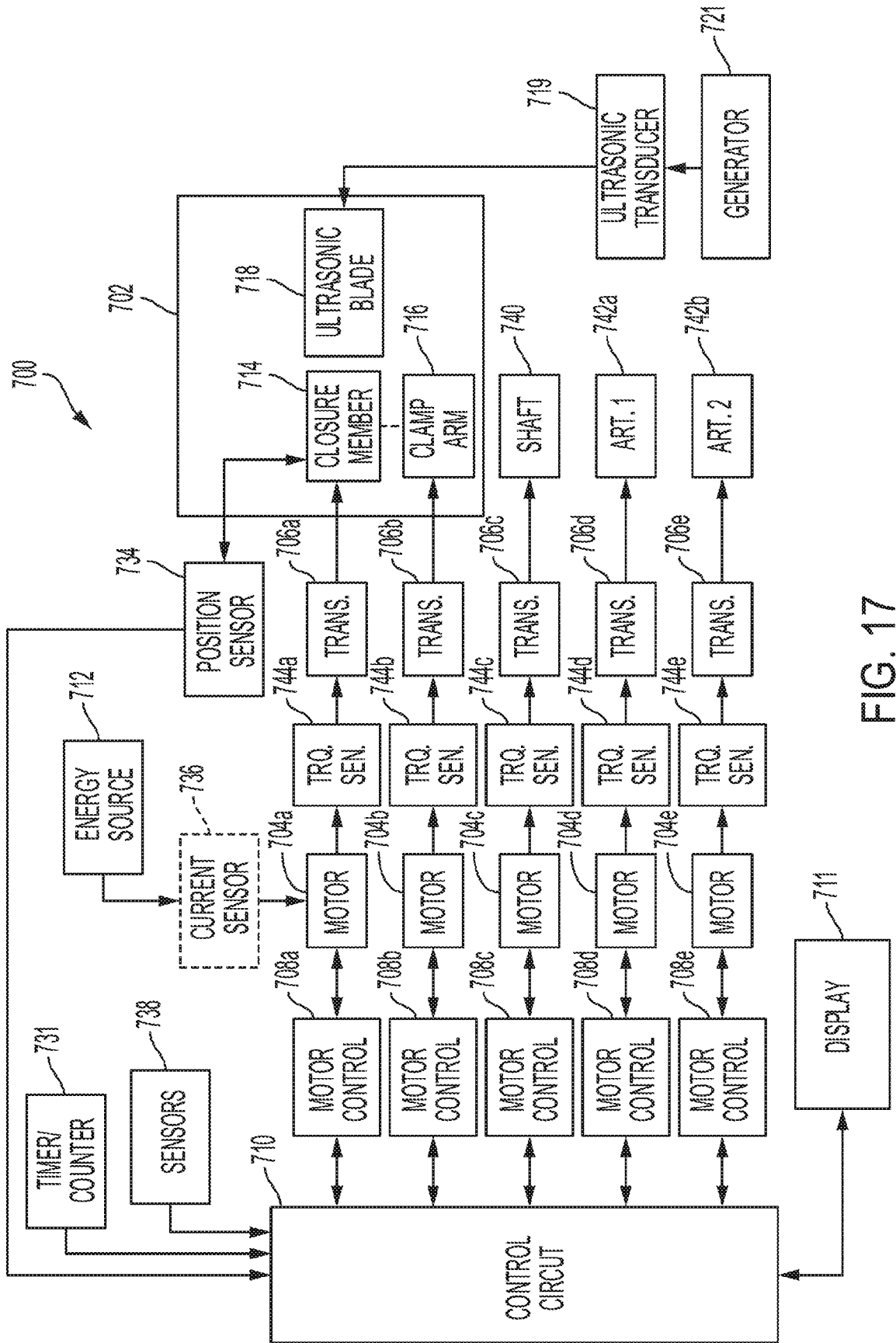

FIG. 17

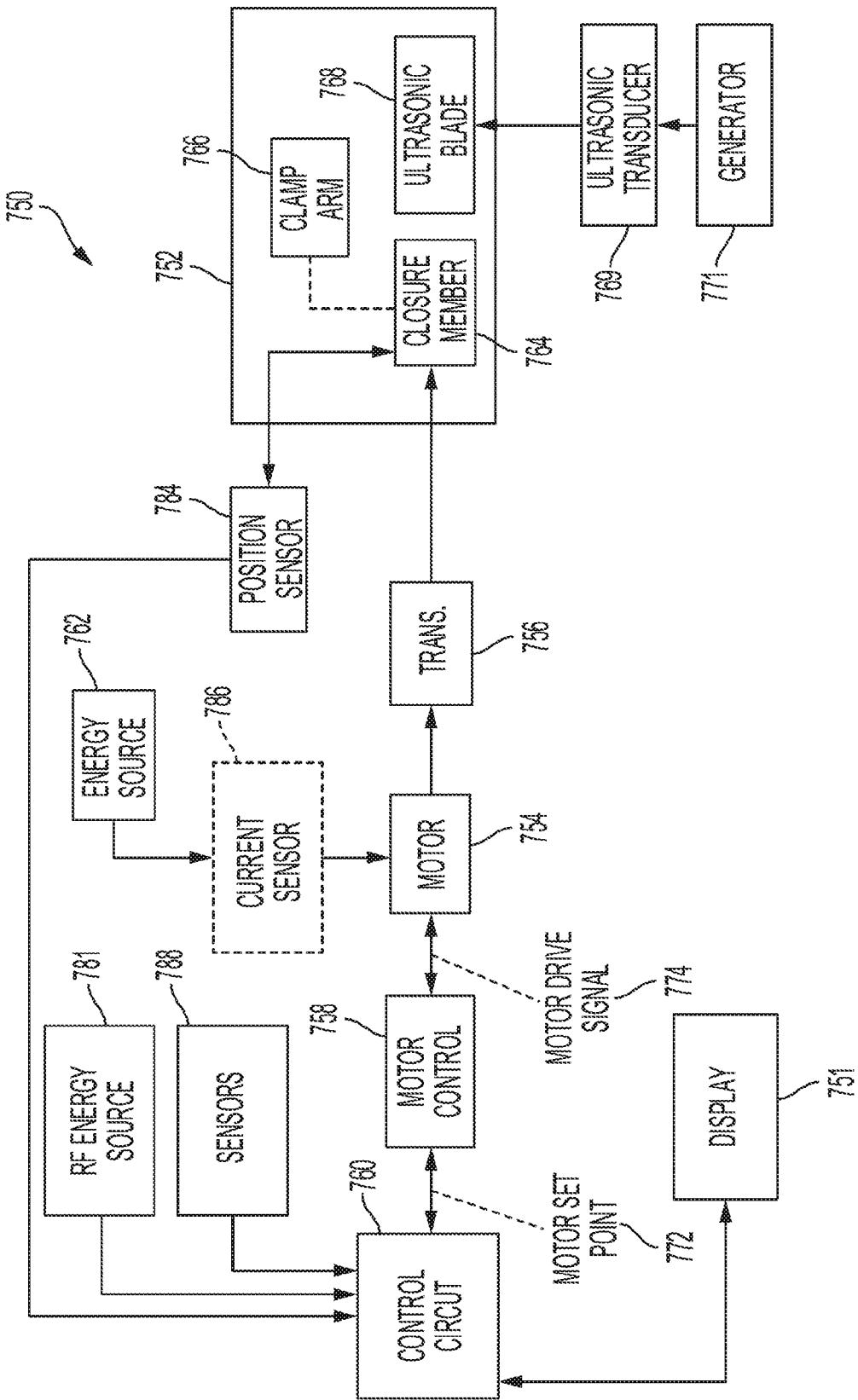

FIG. 18

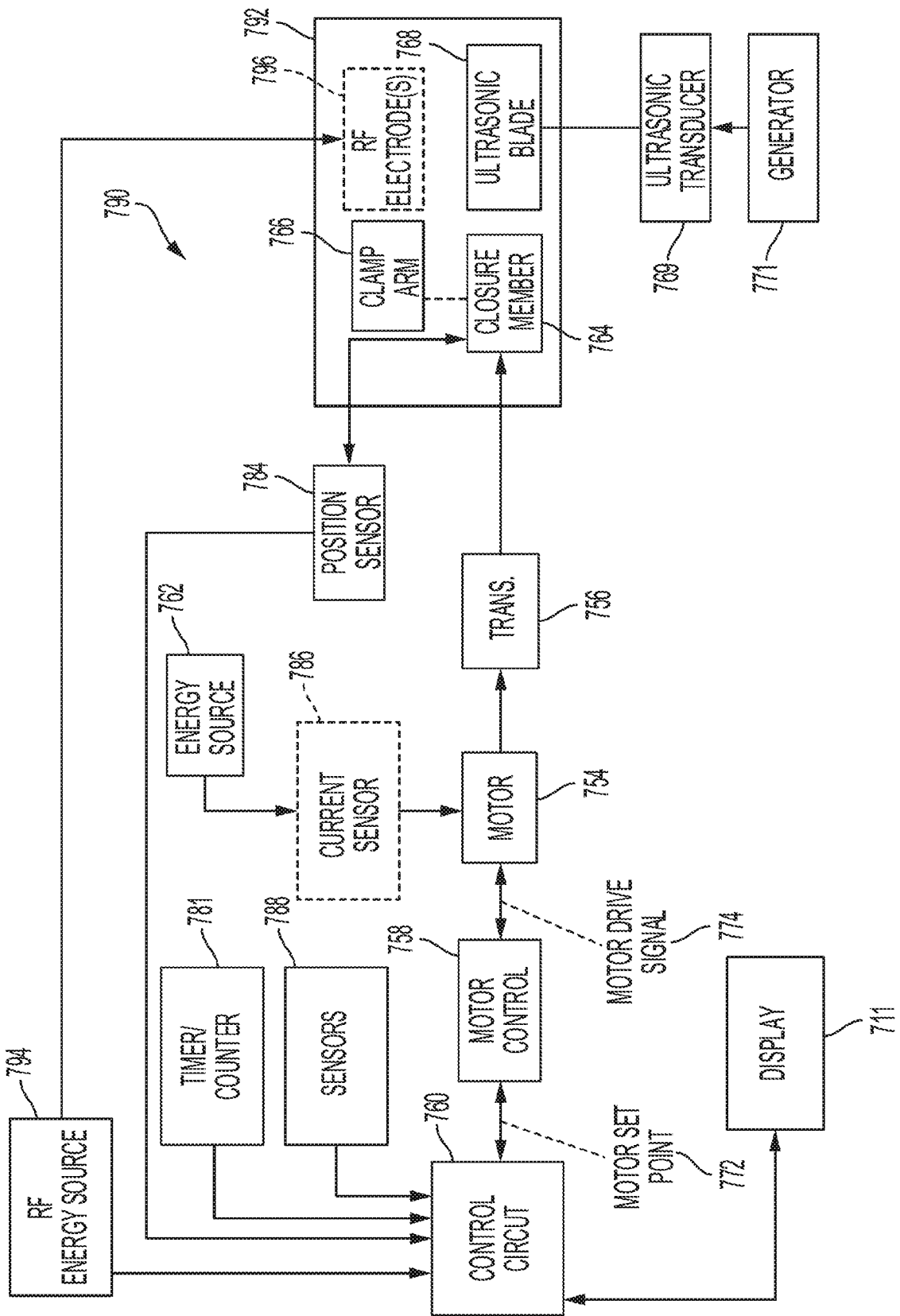

FIG. 19

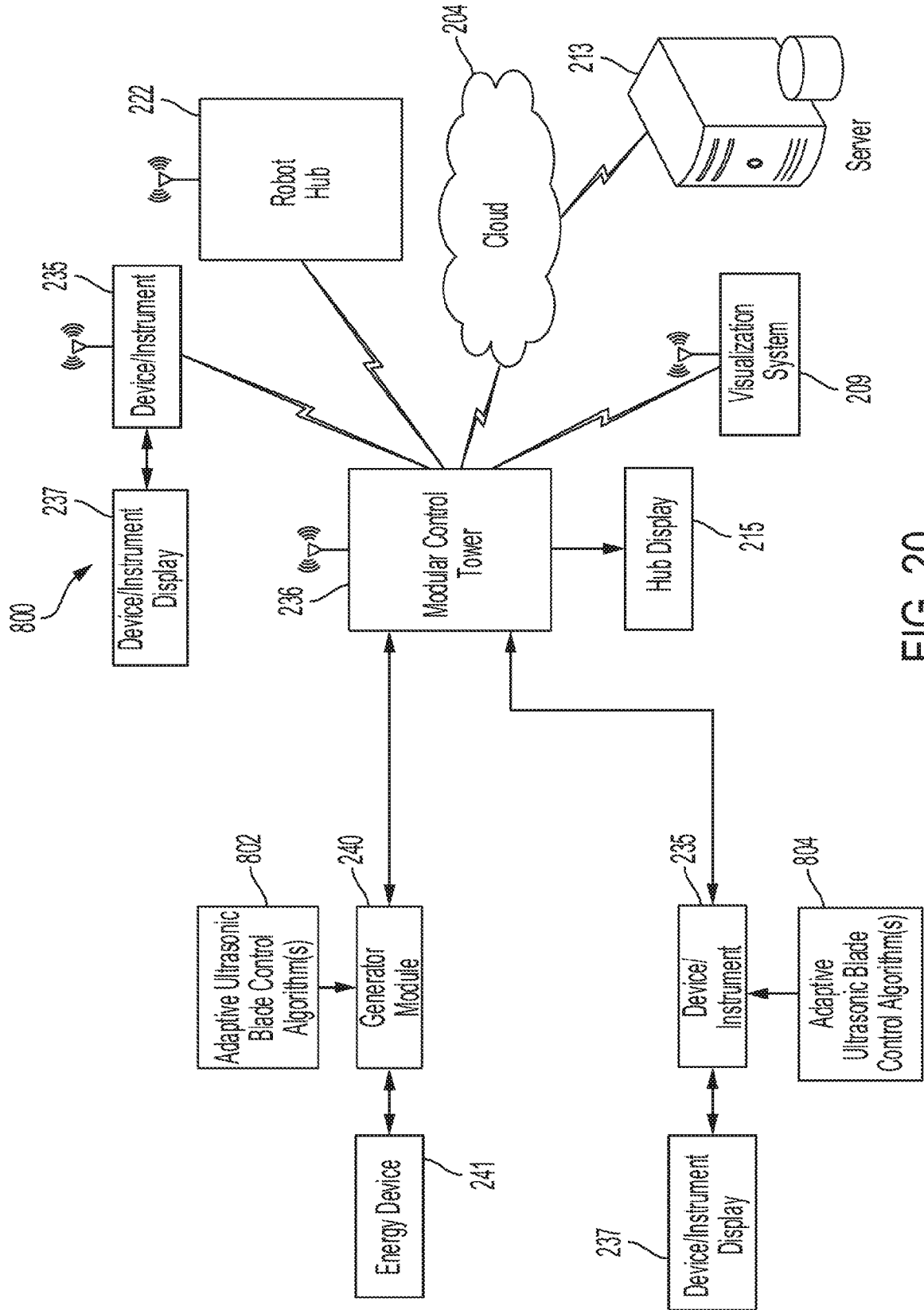

FIG. 20

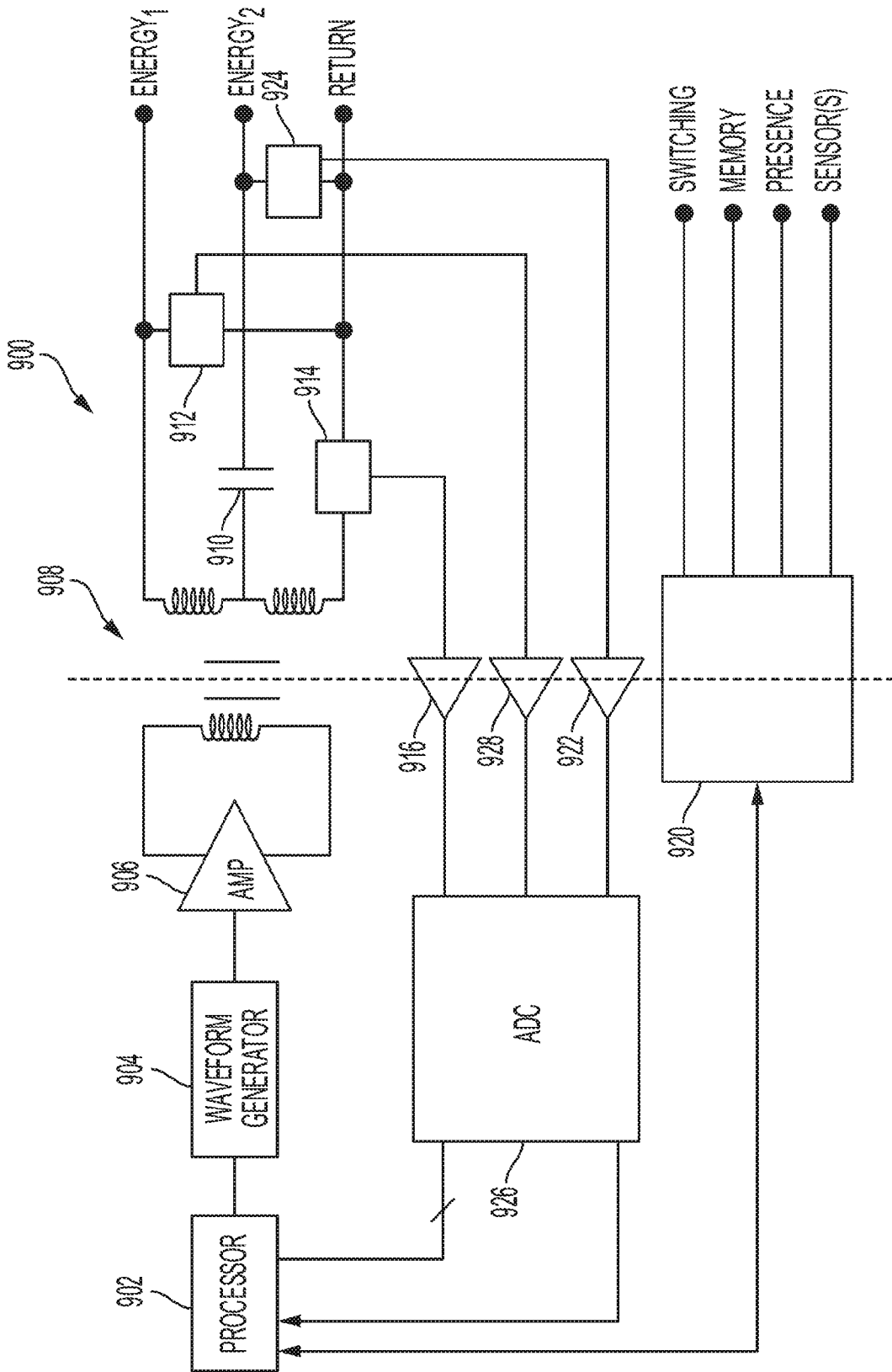

FIG. 21

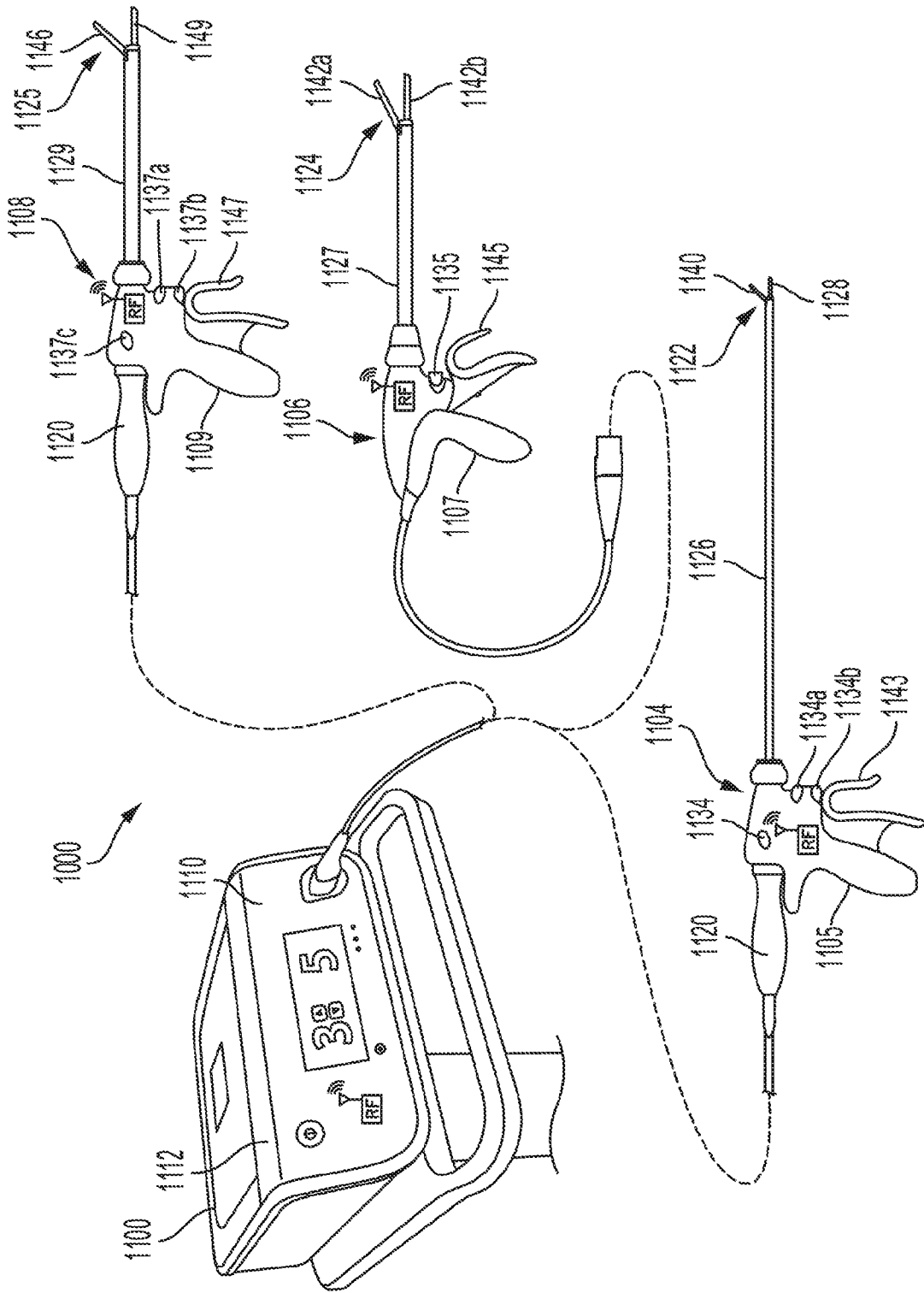

FIG. 22

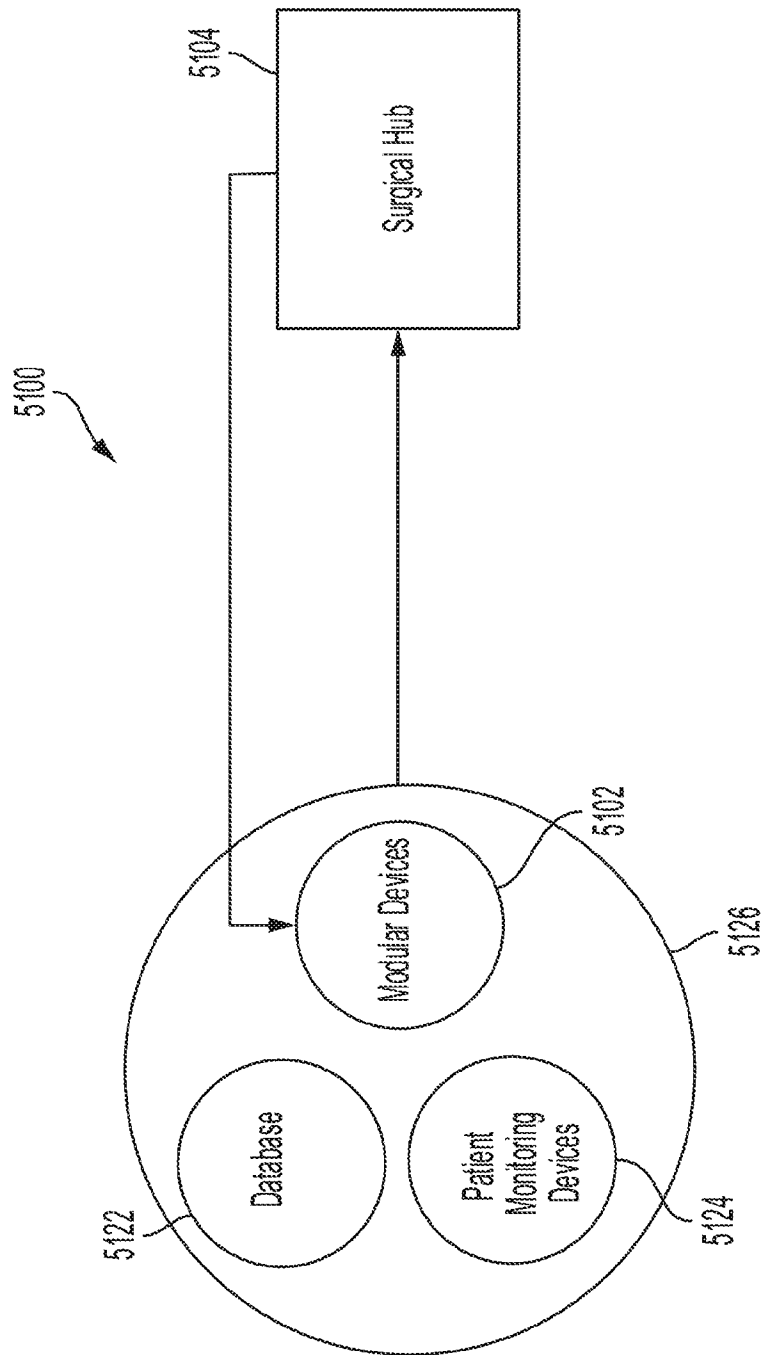
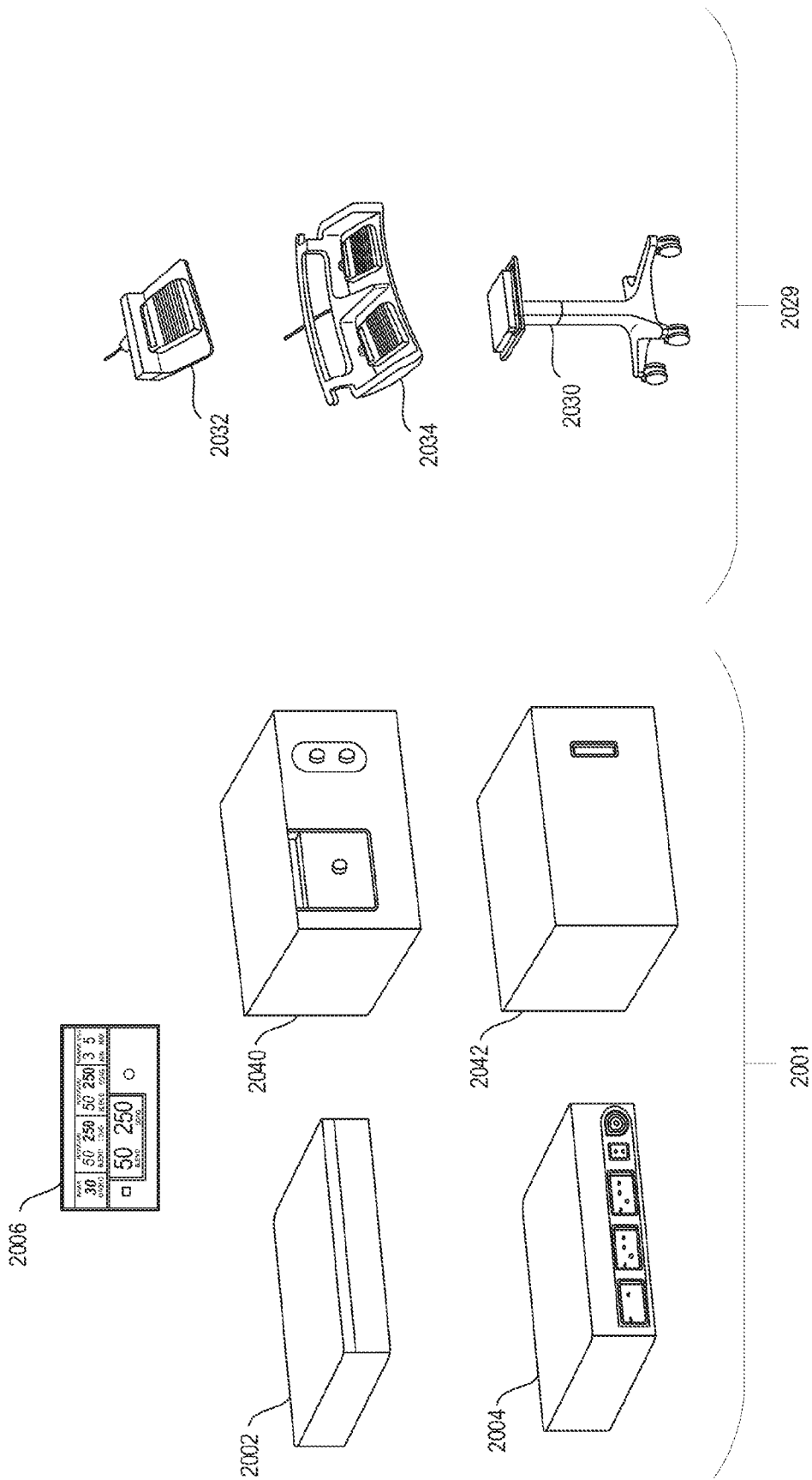

FIG. 23



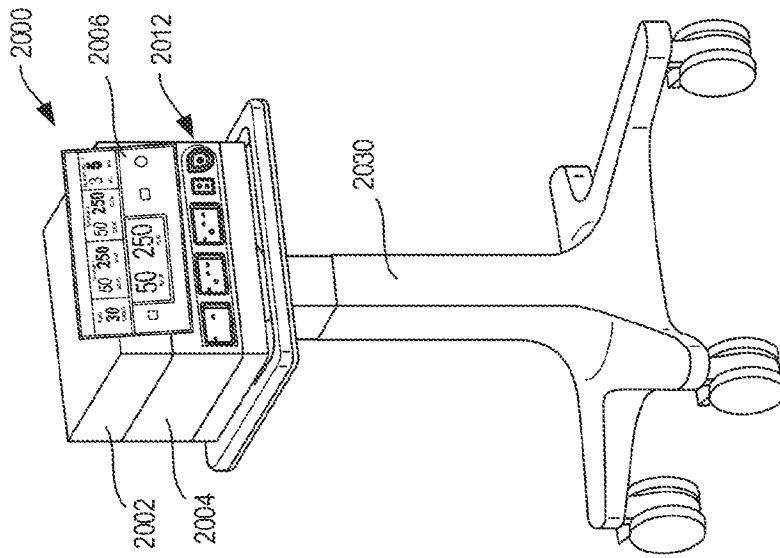

FIG. 25B

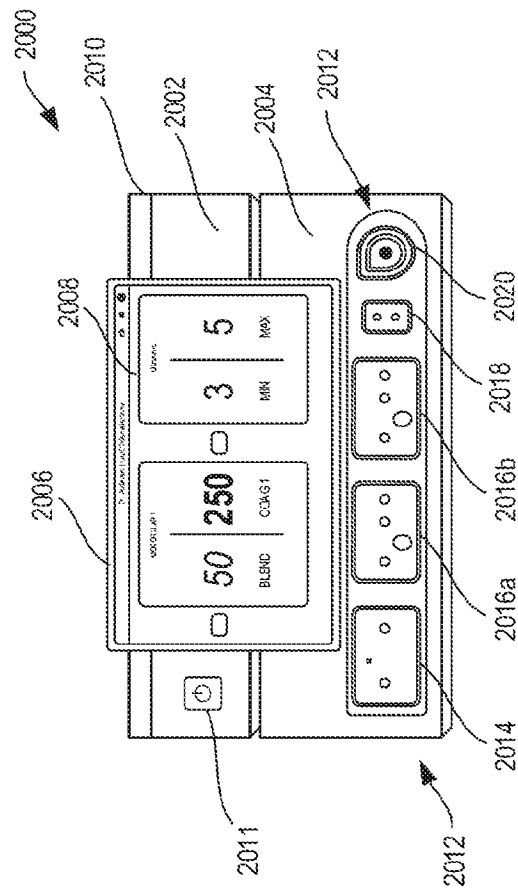

FIG. 25A

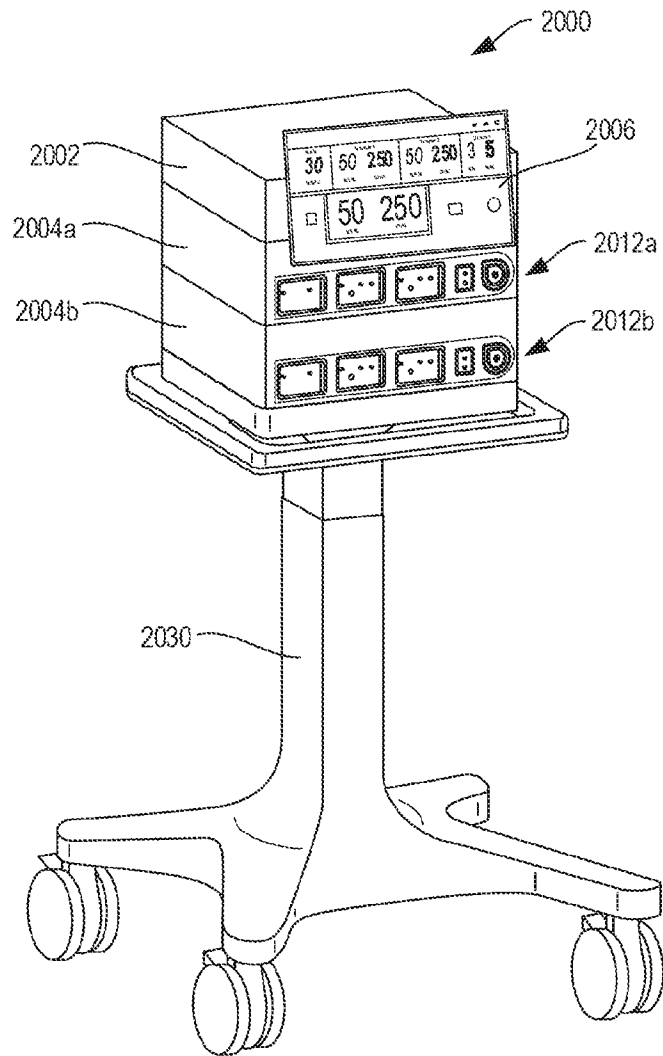

FIG. 26A

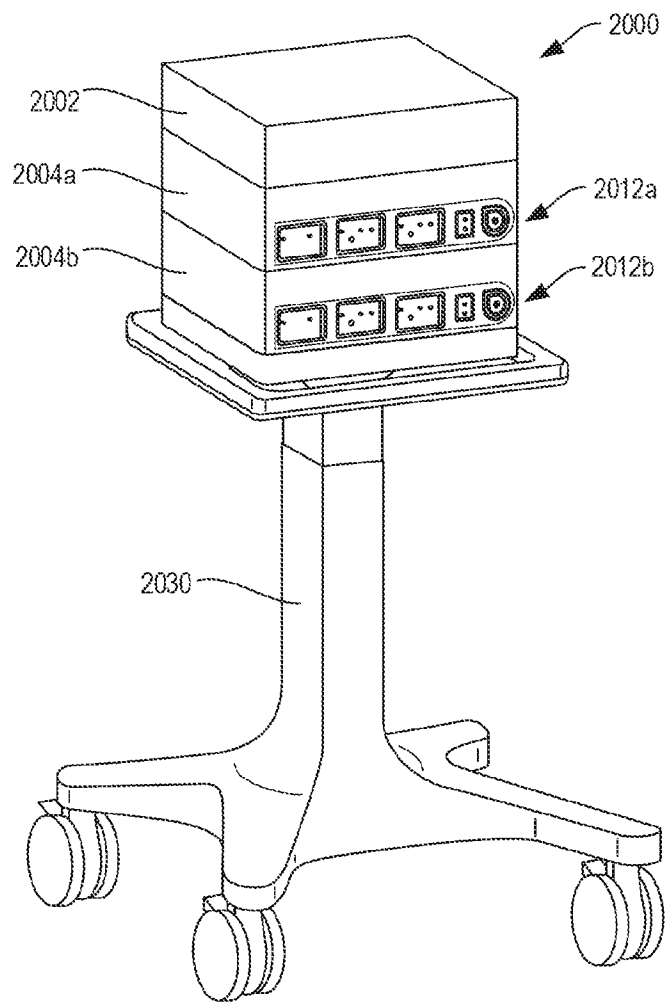

FIG. 26B

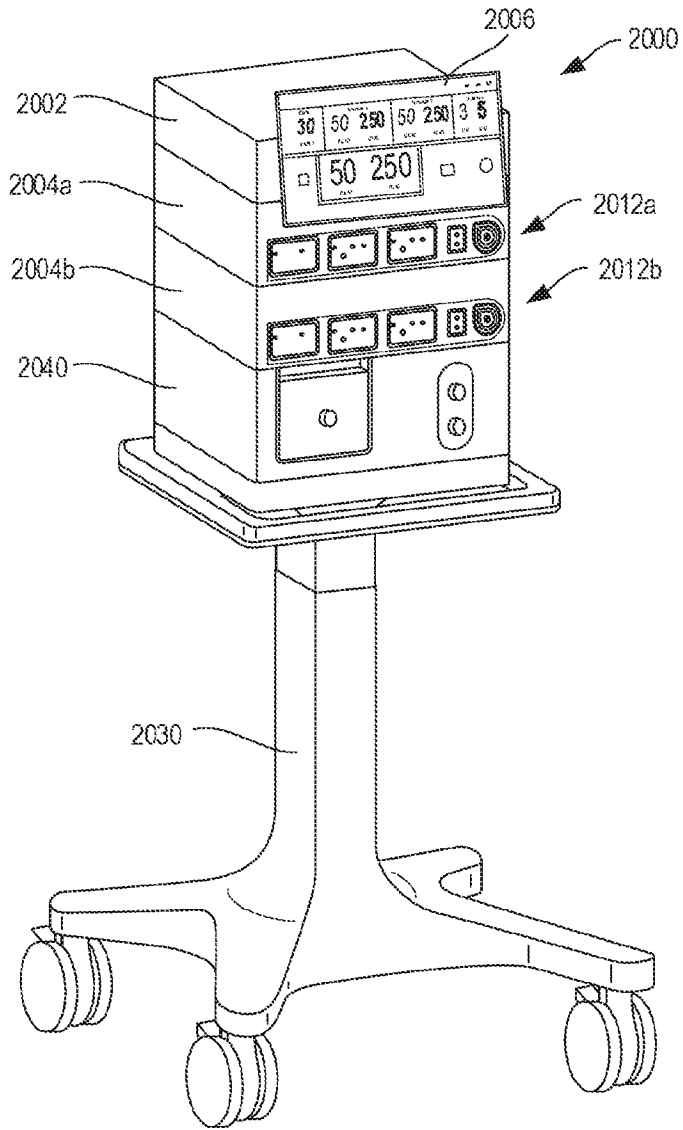

FIG. 27

26/40

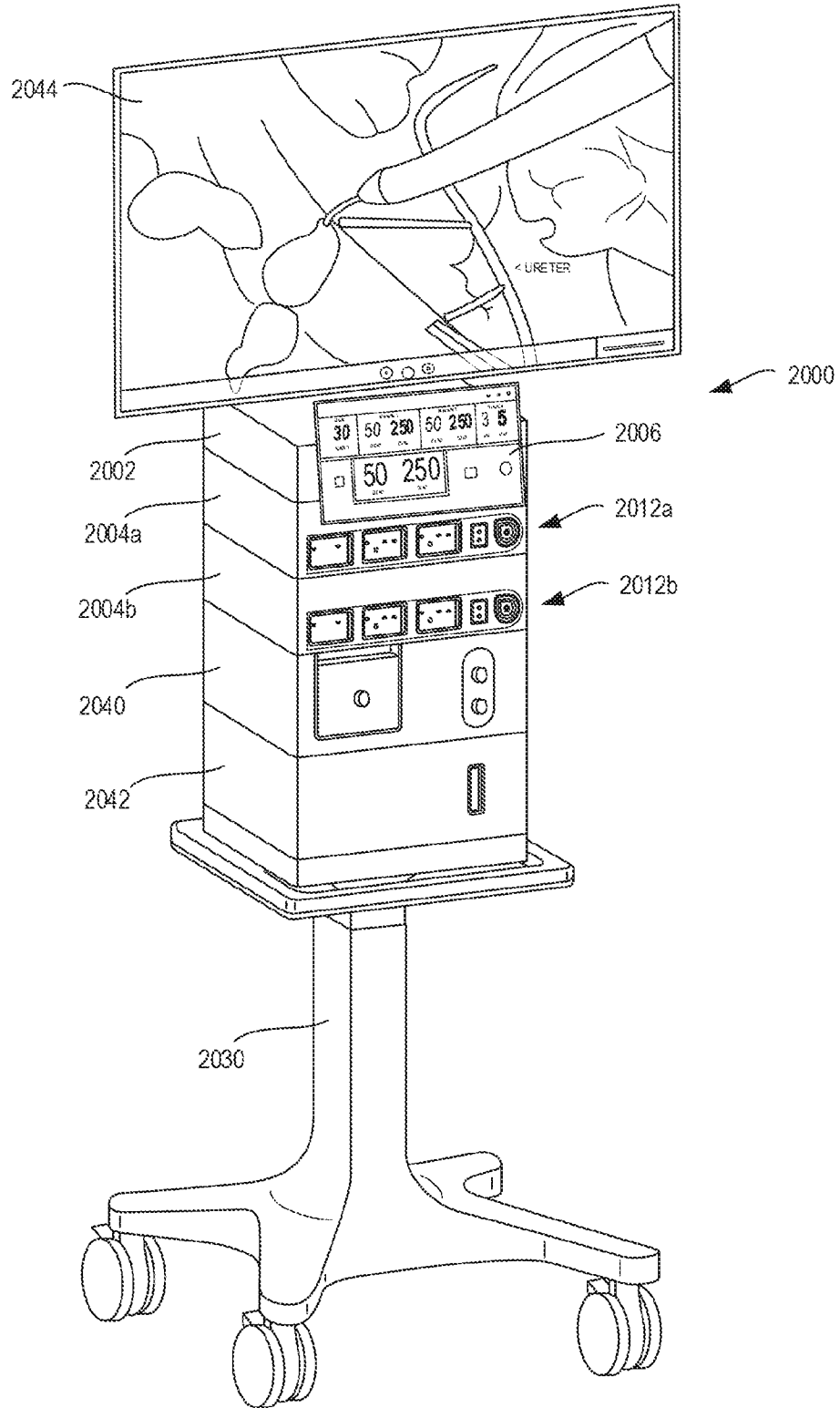

FIG. 28

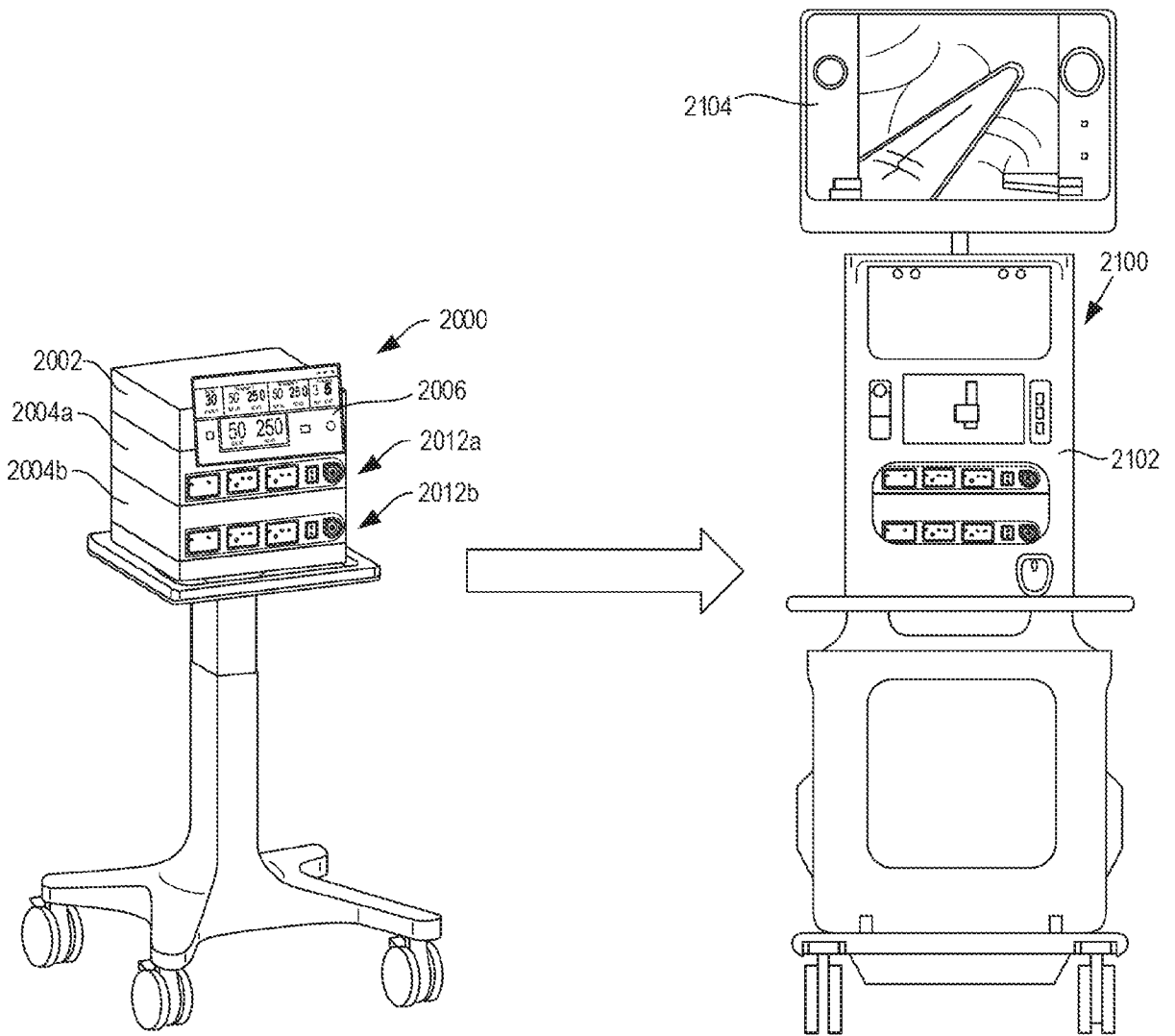

FIG. 29

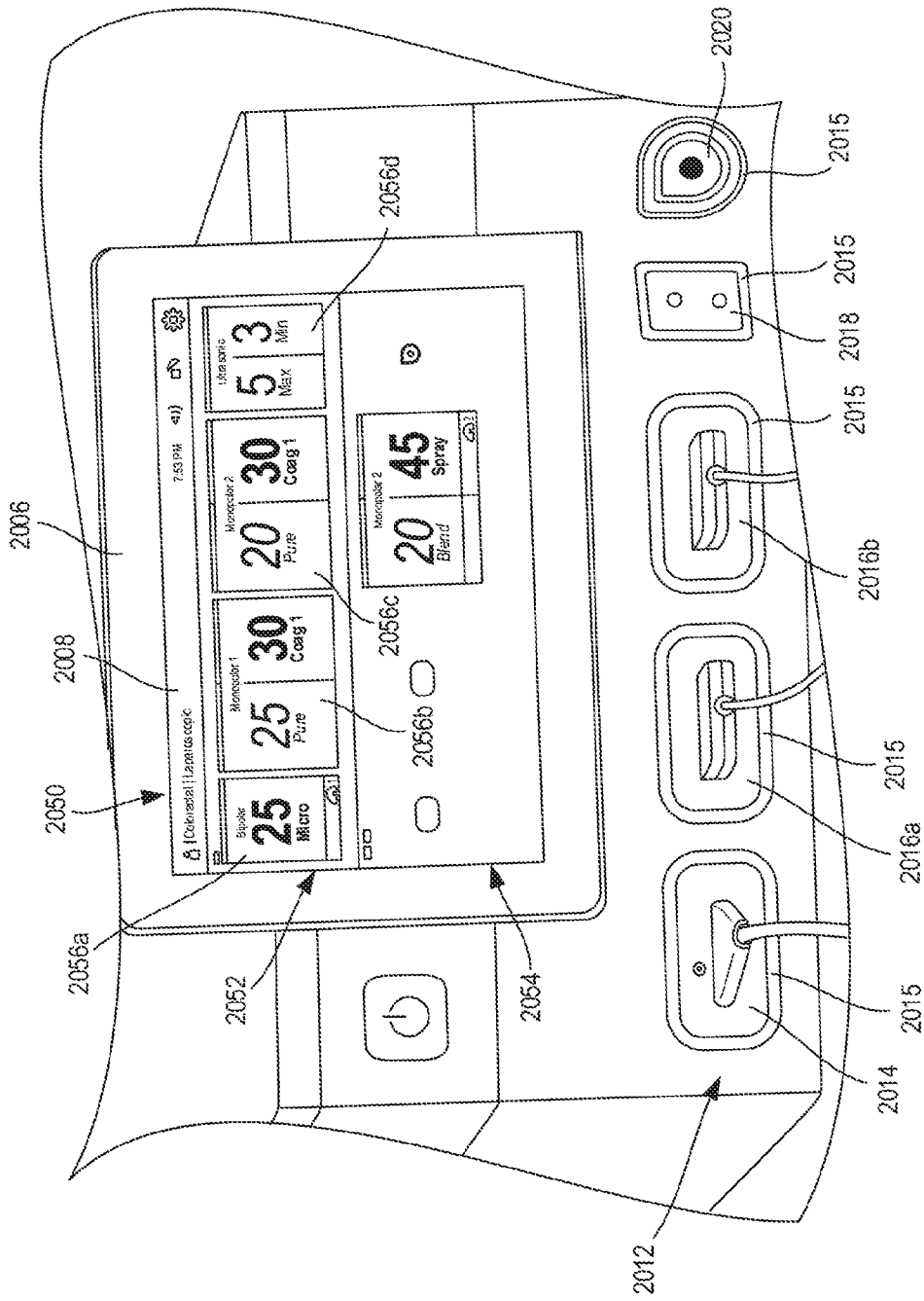

FIG. 30

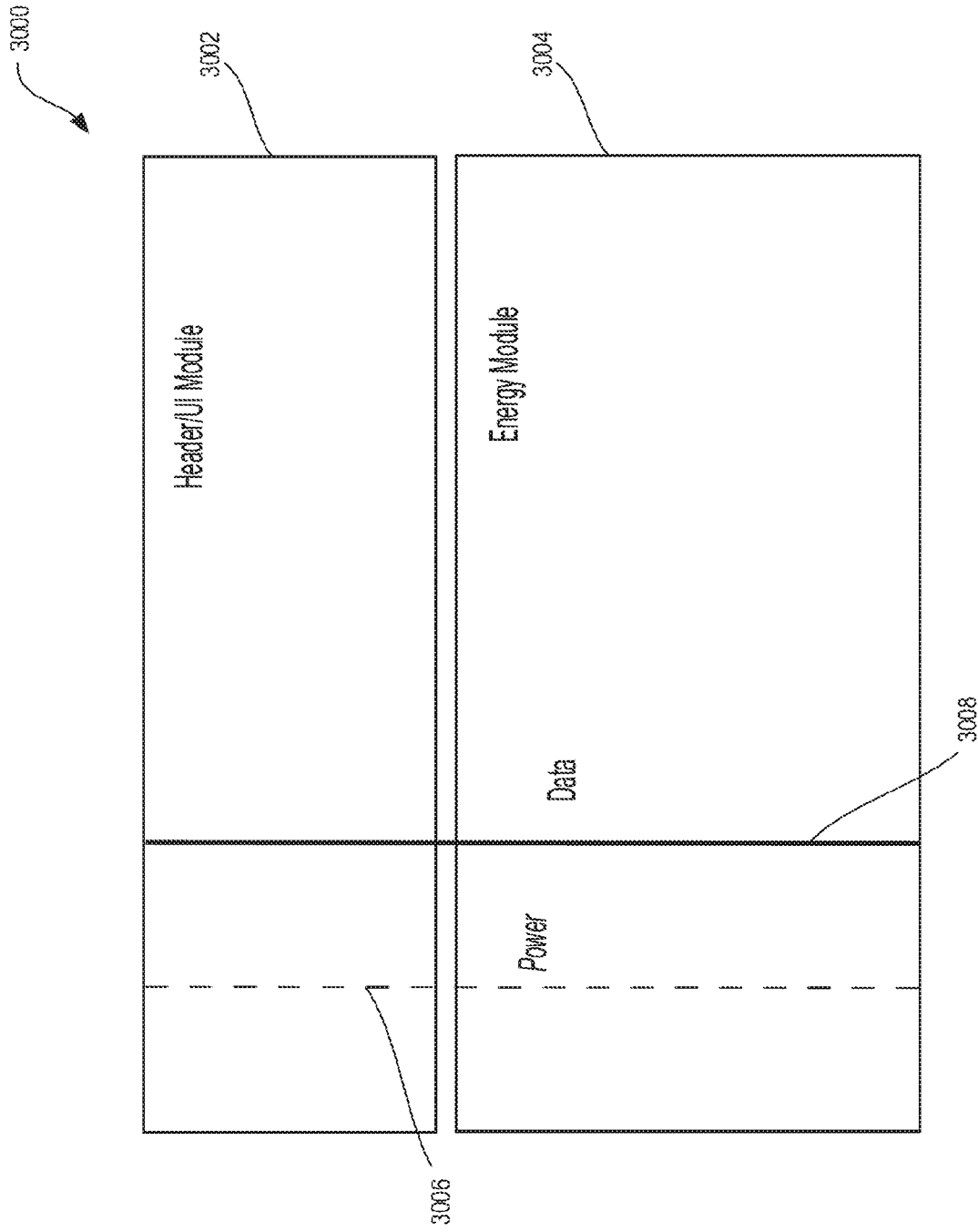

FIG. 31

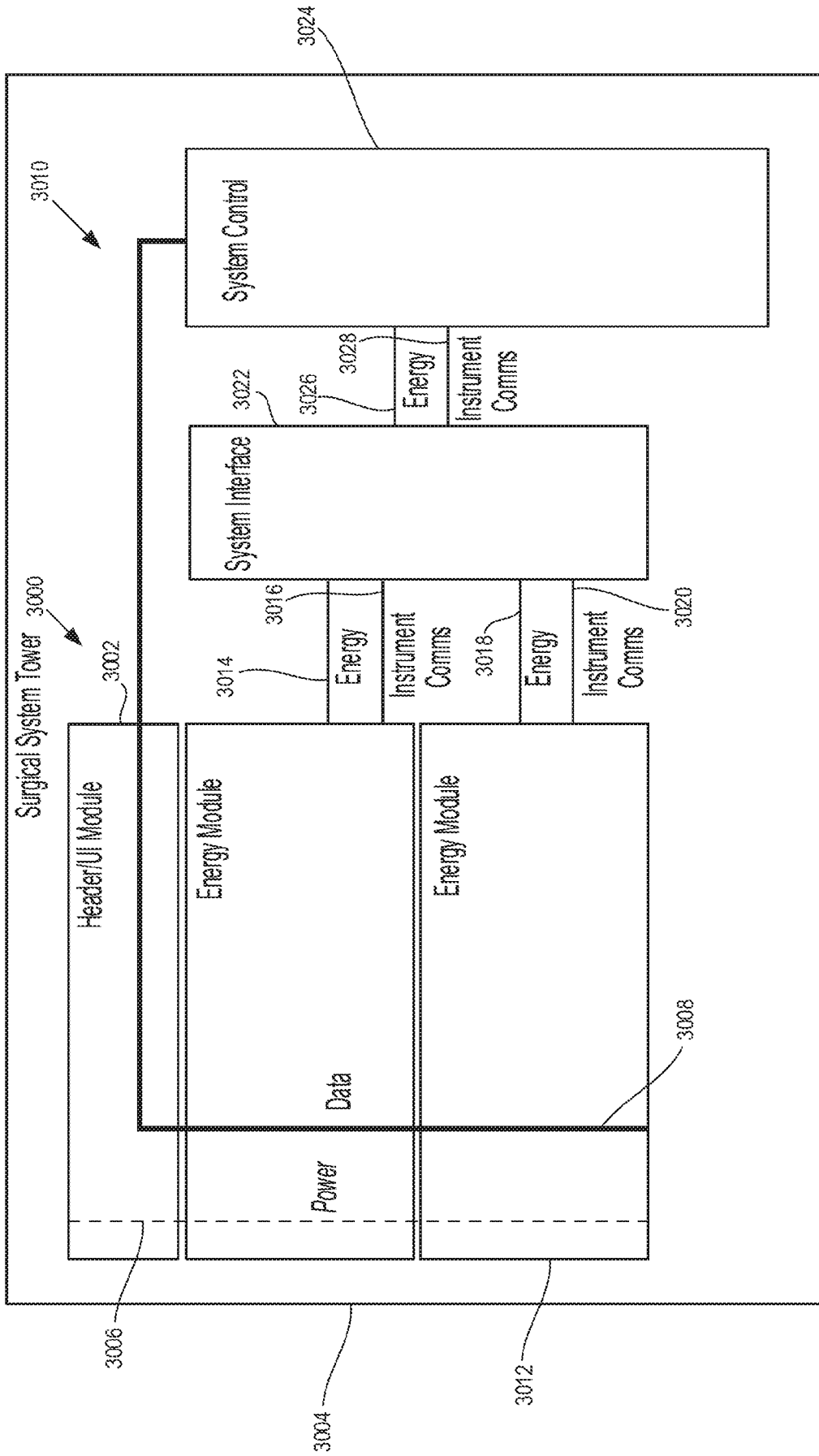
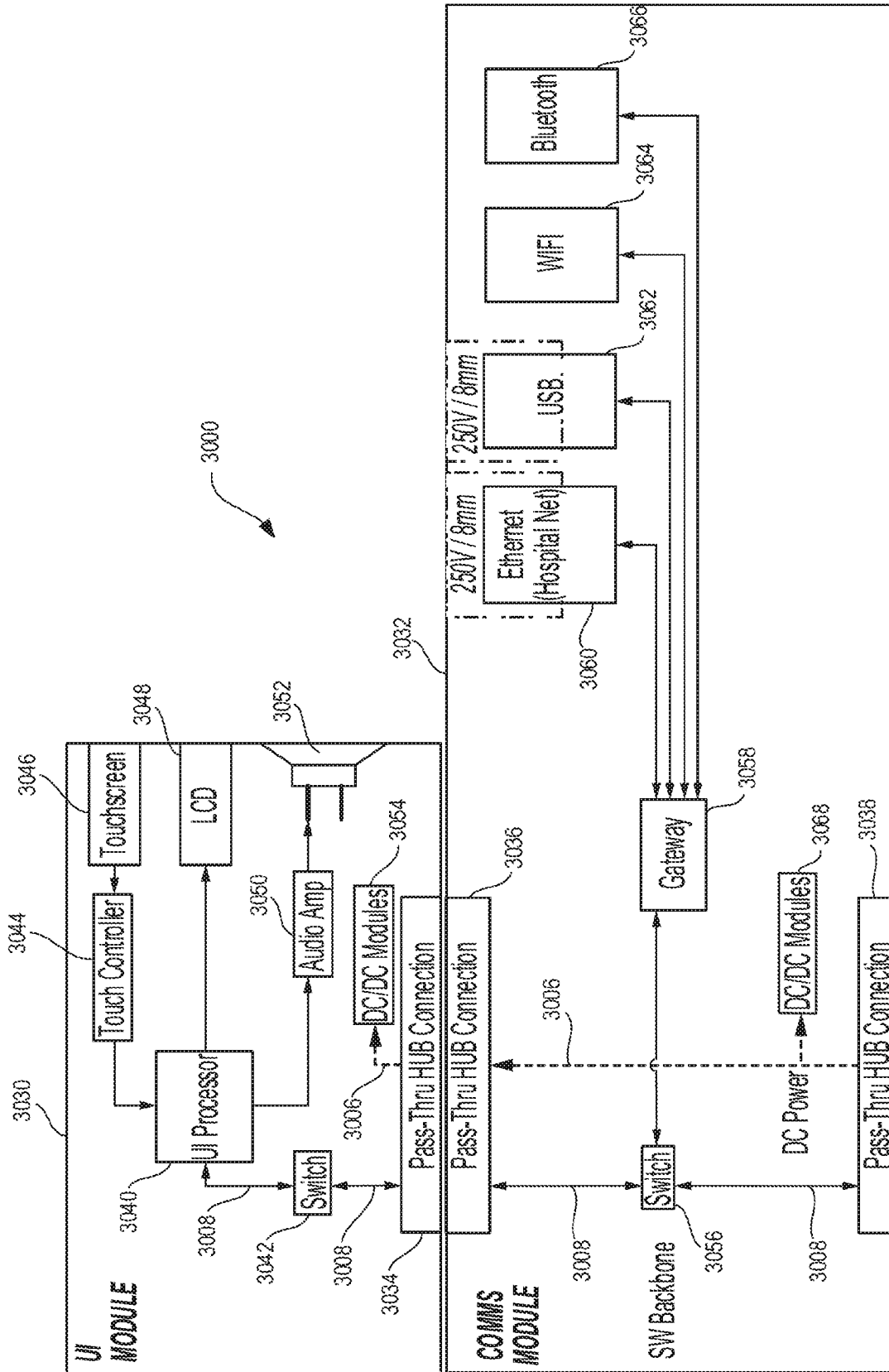
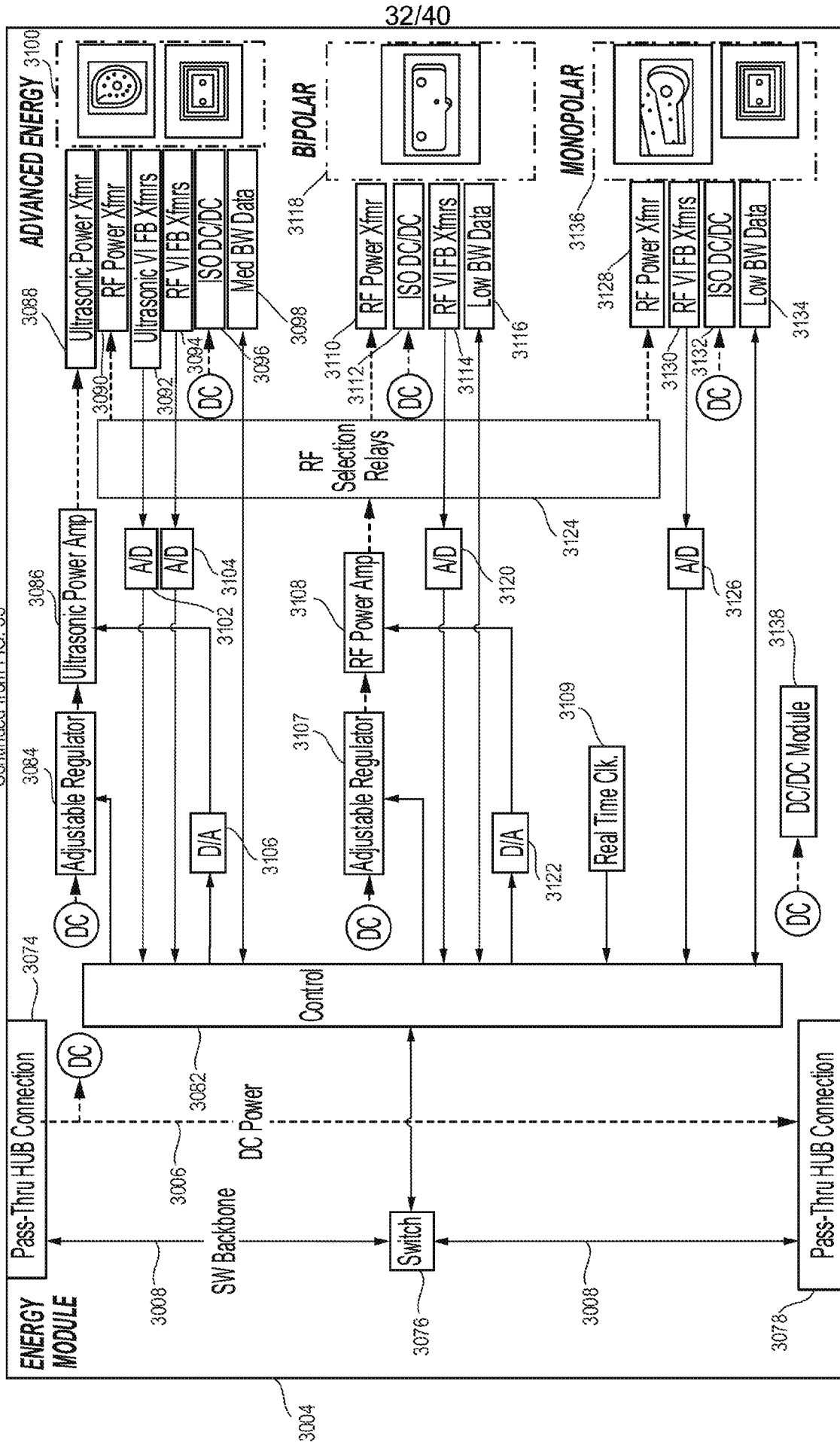

FIG. 32



Continued on FIG. 34

FIG. 33



Continued from FIG. 33

Continued on FIG. 35

FIG. 34

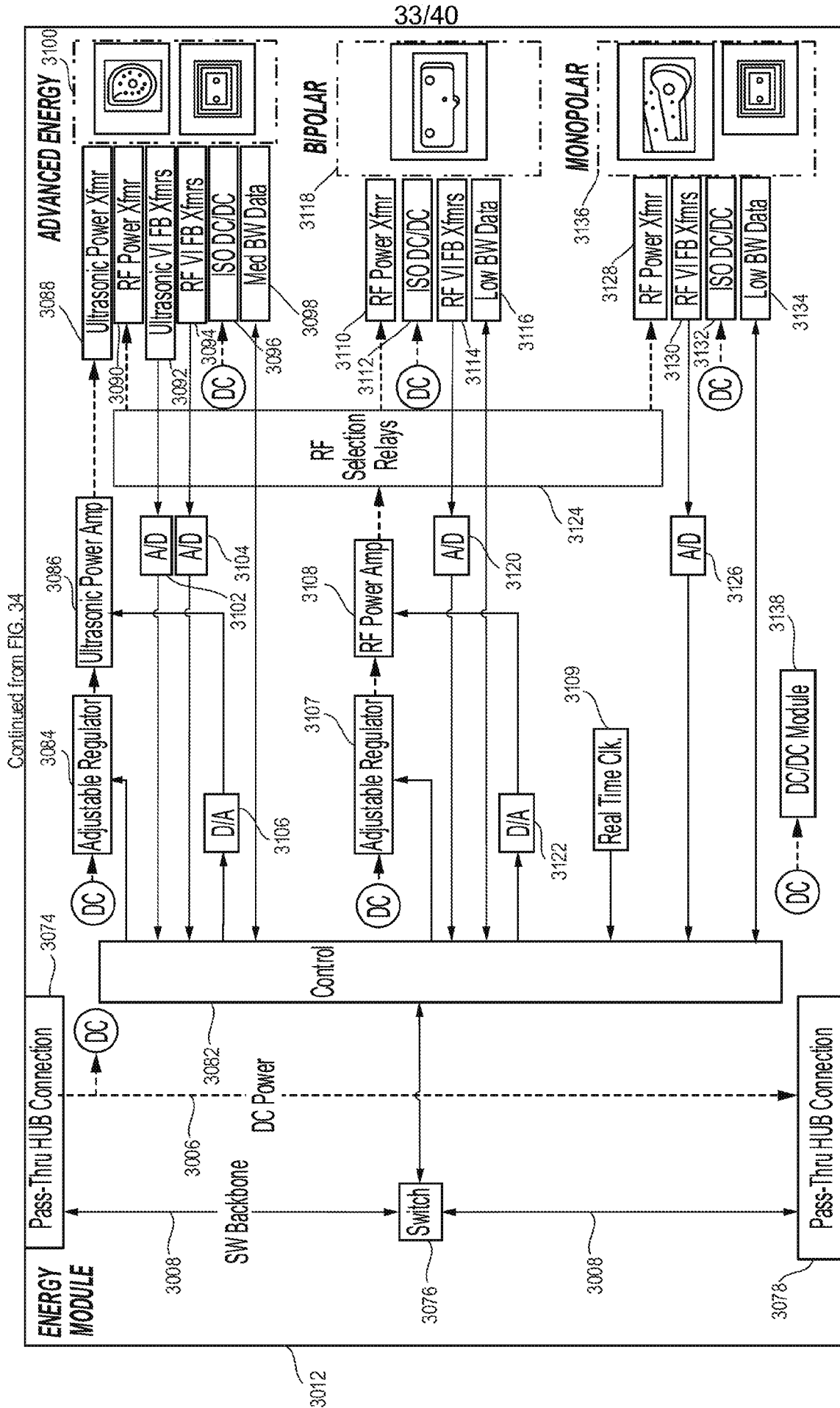

Continued on FIG. 35B

FIG. 35A

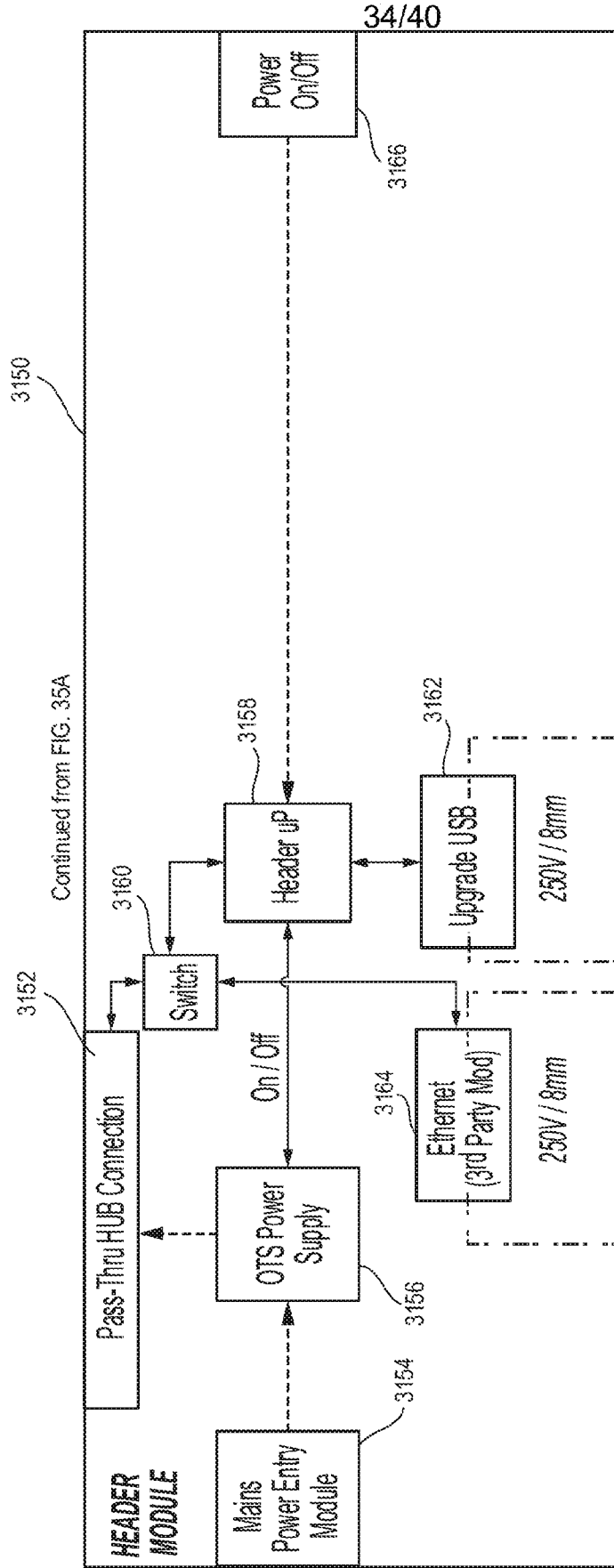

34/40

FIG. 35B

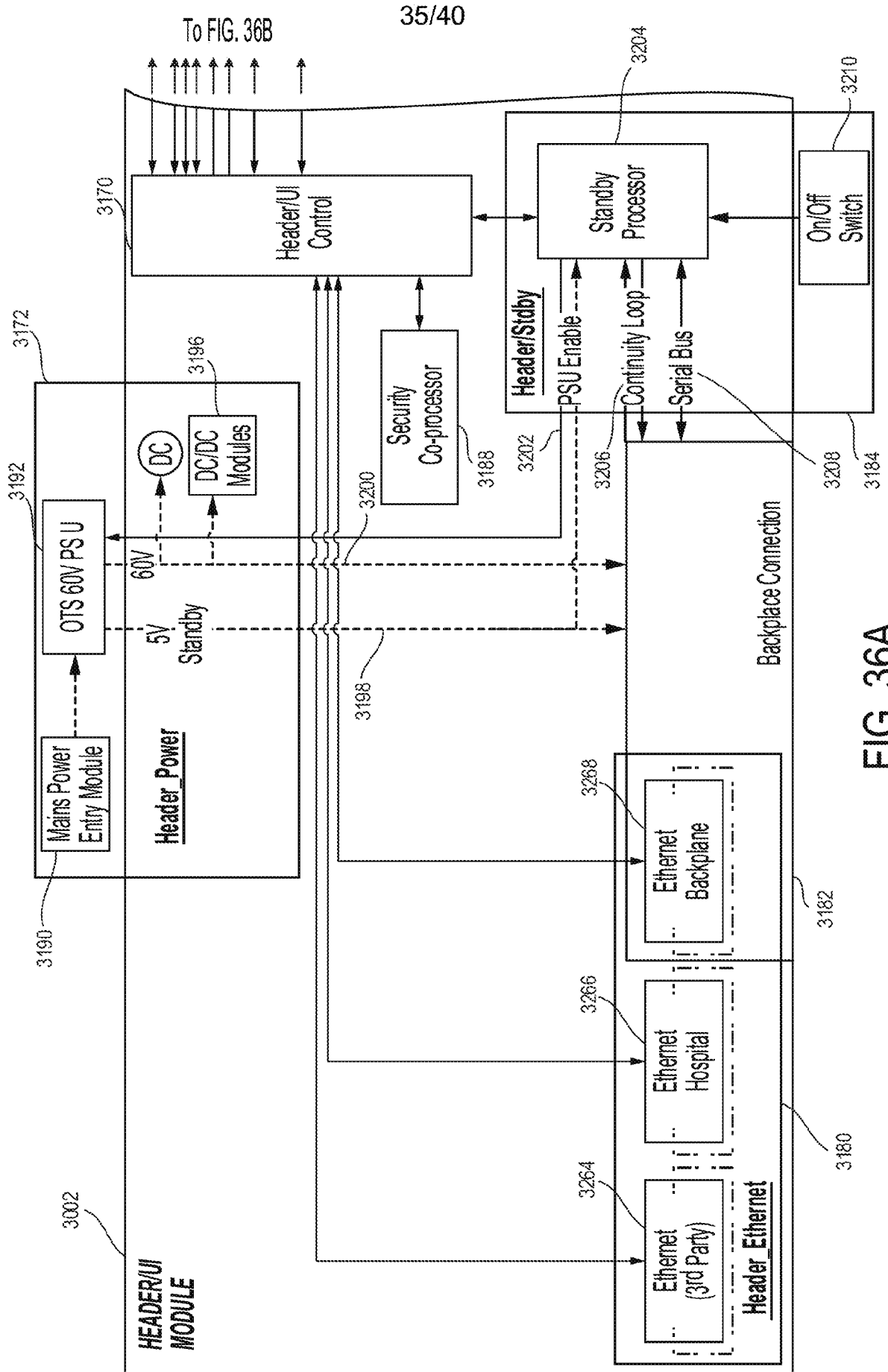

FIG. 36A

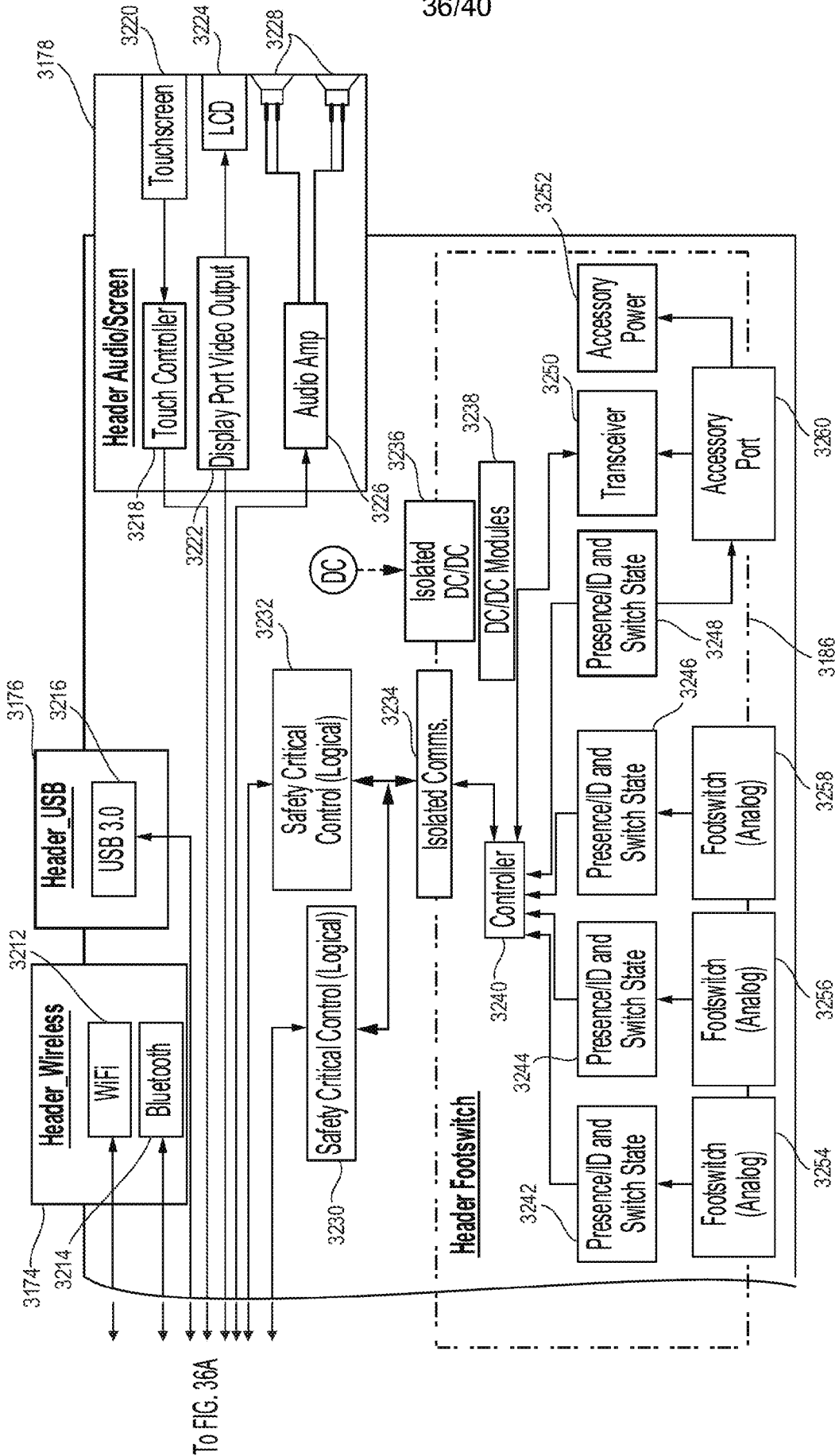

FIG. 36B

To FIG. 36A

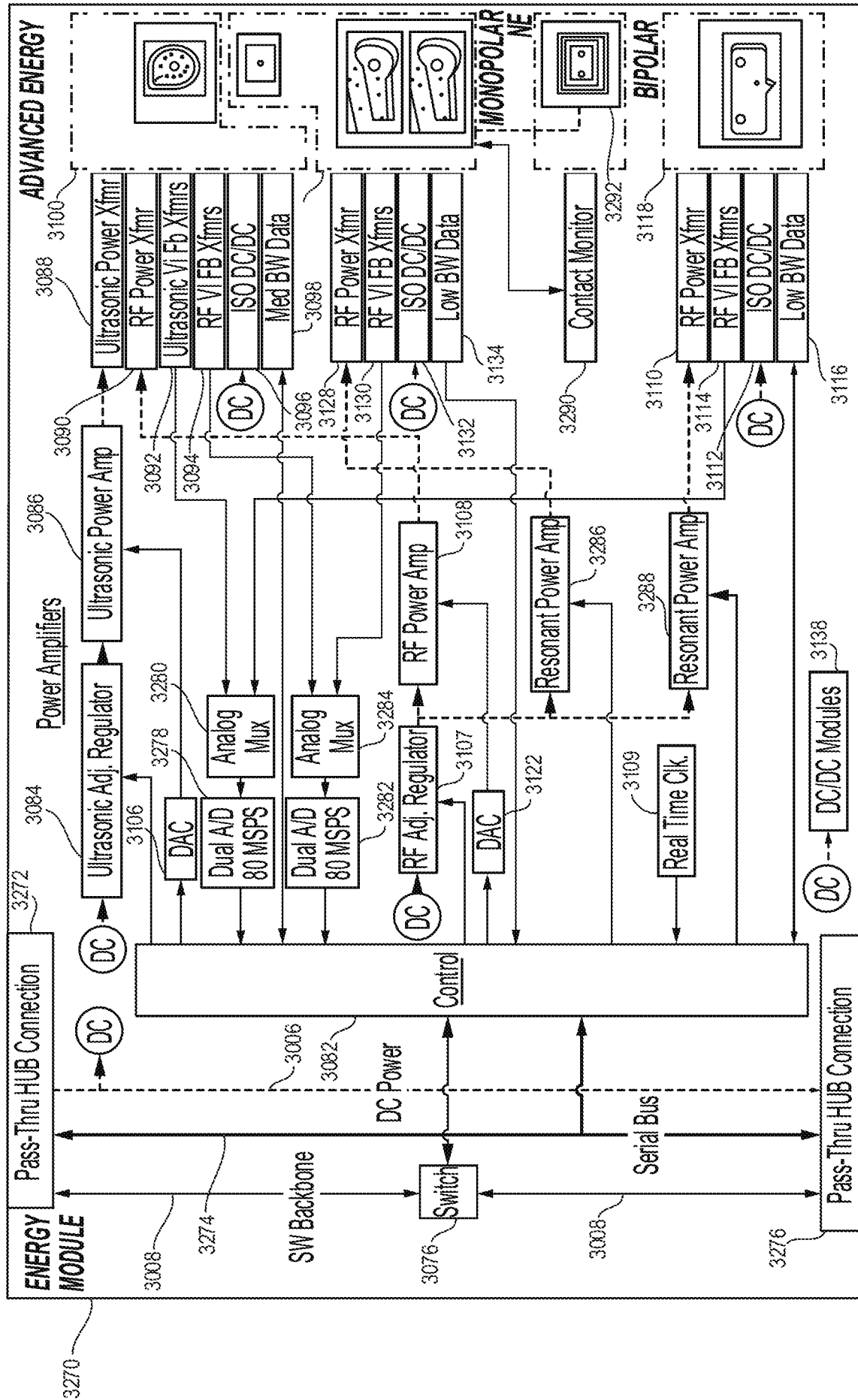

FIG. 37

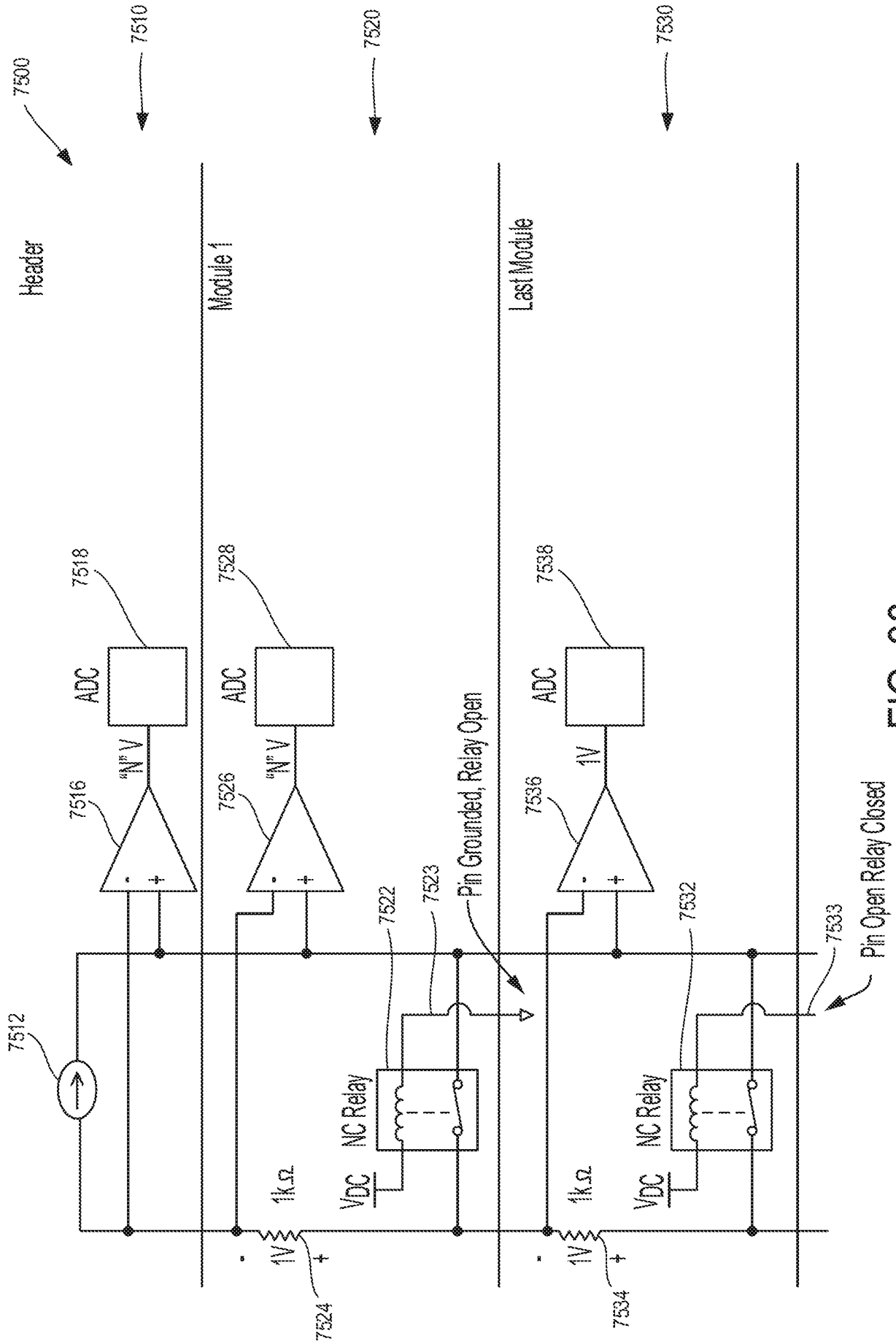

FIG. 38

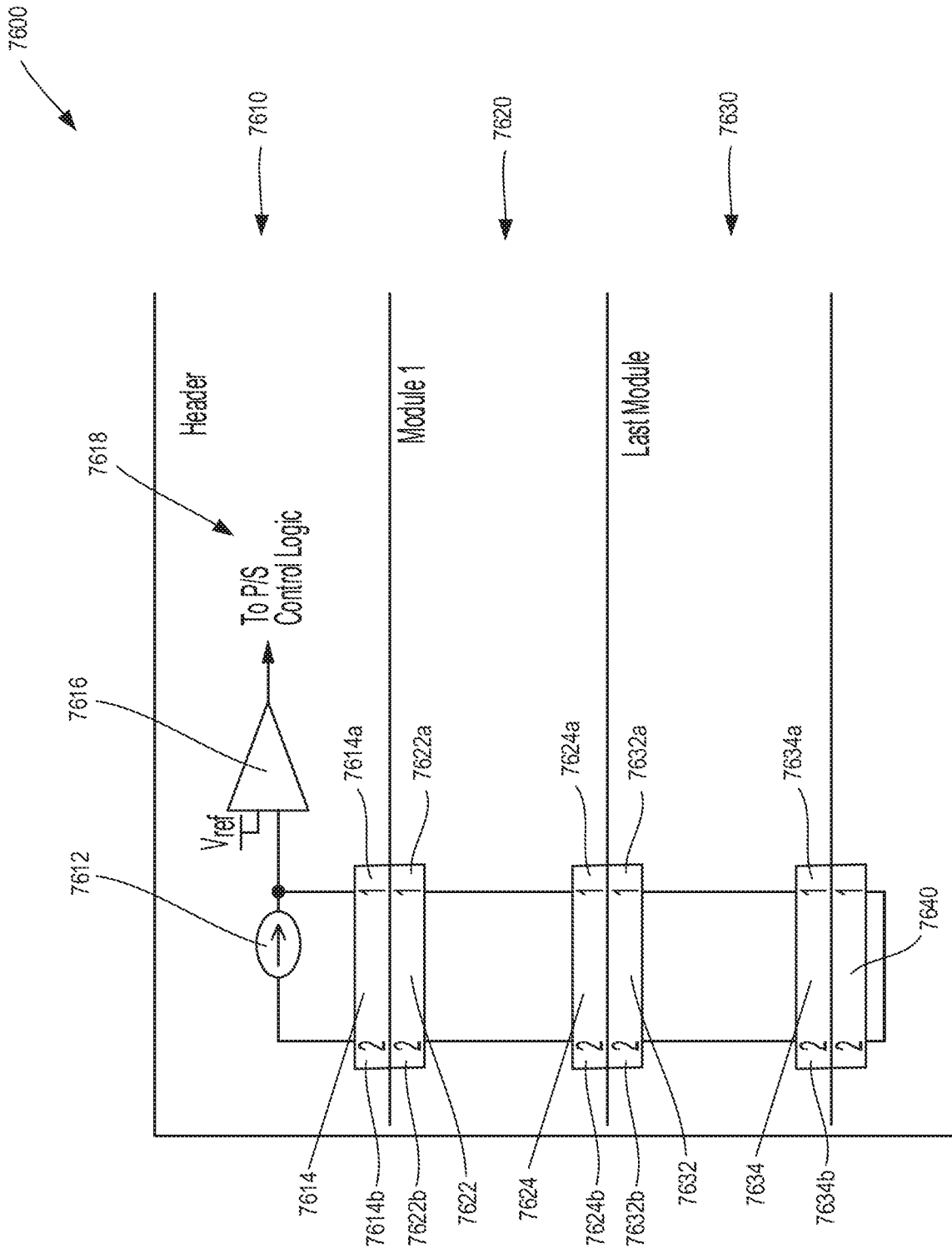

FIG. 39

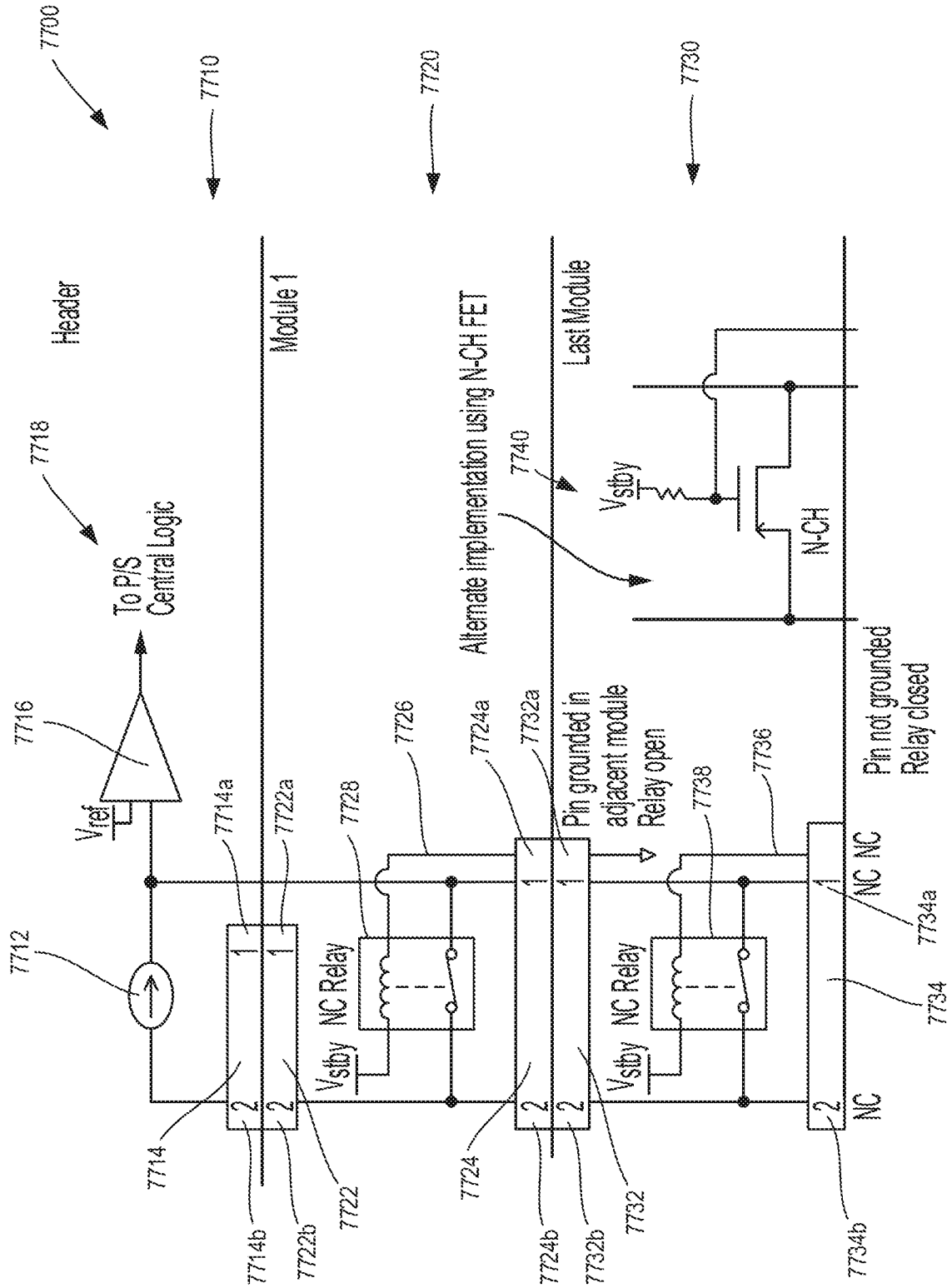

FIG. 40

INTERNATIONAL SEARCH REPORT

International application No
PCT/US2019/049982

A. CLASSIFICATION OF SUBJECT MATTER
 INV. A61B18/12 A61B90/90 H05K5/00 H05K7/02
 ADD. A61B17/32 A61B18/14 A61B34/20

According to International Patent Classification (IPC) or to both national classification and IPC

B. FIELDS SEARCHED
 Minimum documentation searched (classification system followed by classification symbols)
 A61B H05K

Documentation searched other than minimum documentation to the extent that such documents are included in the fields searched

Electronic data base consulted during the international search (name of data base and, where practicable, search terms used)
 EPO-Internal, WPI Data

C. DOCUMENTS CONSIDERED TO BE RELEVANT

Category*	Citation of document, with indication, where appropriate, of the relevant passages	Relevant to claim No.
X	EP 0 929 263 A1 (BAUSCH & LOMB SURGICAL INC [US]) 21 July 1999 (1999-07-21)	1-4,6-20
Y	paragraphs [0013] - [0019], [0023], [0053], [0078], [0112], [0113]; figures 1, 3, 12, 23	5
Y	----- US 5 189 277 A (BOISVERT JOHN A [US] ET AL) 23 February 1993 (1993-02-23) columns 15-17, lines 21-16; figures 1, 13, 13A	5
A	----- US 8 917 513 B1 (HAZZARD TIM [US]) 23 December 2014 (2014-12-23) lines 65-25, paragraph 5-6; figures 1, 2	1-20

Further documents are listed in the continuation of Box C.

See patent family annex.

* Special categories of cited documents :

<p>"A" document defining the general state of the art which is not considered to be of particular relevance</p> <p>"E" earlier application or patent but published on or after the international filing date</p> <p>"L" document which may throw doubts on priority claim(s) or which is cited to establish the publication date of another citation or other special reason (as specified)</p> <p>"O" document referring to an oral disclosure, use, exhibition or other means</p> <p>"P" document published prior to the international filing date but later than the priority date claimed</p>	<p>"T" later document published after the international filing date or priority date and not in conflict with the application but cited to understand the principle or theory underlying the invention</p> <p>"X" document of particular relevance; the claimed invention cannot be considered novel or cannot be considered to involve an inventive step when the document is taken alone</p> <p>"Y" document of particular relevance; the claimed invention cannot be considered to involve an inventive step when the document is combined with one or more other such documents, such combination being obvious to a person skilled in the art</p> <p>"&" document member of the same patent family</p>
---	---

Date of the actual completion of the international search <p align="center">6 December 2019</p>	Date of mailing of the international search report <p align="center">16/12/2019</p>
--	--

Name and mailing address of the ISA/ European Patent Office, P.B. 5818 Patentlaan 2 NL - 2280 HV Rijswijk Tel. (+31-70) 340-2040, Fax: (+31-70) 340-3016	Authorized officer <p align="center">Tomelleri, C</p>
--	--

INTERNATIONAL SEARCH REPORT

Information on patent family members

International application No

PCT/US2019/049982

Patent document cited in search report	Publication date	Patent family member(s)	Publication date
EP 0929263	A1	21-07-1999	
		AU 714226 B2	23-12-1999
		AU 720530 B2	01-06-2000
		AU 723086 B2	17-08-2000
		AU 723513 B2	31-08-2000
		AU 723523 B2	31-08-2000
		AU 723587 B2	31-08-2000
		AU 723829 B2	07-09-2000
		AU 724661 B2	28-09-2000
		AU 4093997 A	19-03-1998
		AU 4169397 A	19-03-1998
		AU 4239497 A	19-03-1998
		BR 9711274 A	11-12-2001
		BR 9711275 A	16-10-2001
		BR 9711287 A	30-10-2001
		BR 9711288 A	06-11-2001
		BR 9711646 A	06-08-2002
		CA 2263975 A1	05-03-1998
		CA 2264036 A1	05-03-1998
		CA 2264040 A1	05-03-1998
		CA 2264041 A1	05-03-1998
		CA 2264103 A1	05-03-1998
		CA 2264145 A1	05-03-1998
		CA 2264659 A1	05-03-1998
		CA 2264663 A1	05-03-1998
		CA 2264738 A1	05-03-1998
		CN 1231589 A	13-10-1999
		CN 1235527 A	17-11-1999
		CN 1235528 A	17-11-1999
		CN 1235529 A	17-11-1999
		CN 1235530 A	17-11-1999
		CN 1235531 A	17-11-1999
		CN 1235535 A	17-11-1999
		CN 1236309 A	24-11-1999
		CN 1251507 A	26-04-2000
		CN 1515235 A	28-07-2004
		DE 69728793 D1	27-05-2004
		DE 69728793 T2	23-09-2004
		DE 69731225 D1	18-11-2004
		DE 69731225 T2	03-03-2005
		DE 69734592 D1	15-12-2005
		DE 69734592 T2	10-08-2006
		EP 0929263 A1	21-07-1999
		EP 0949881 A1	20-10-1999
		EP 0951241 A1	27-10-1999
		EP 0955899 A1	17-11-1999
		EP 0955984 A1	17-11-1999
		EP 1006891 A1	14-06-2000
		EP 1006892 A1	14-06-2000
		EP 1006893 A1	14-06-2000
		EP 1006894 A1	14-06-2000
		EP 1550405 A2	06-07-2005
		EP 1550406 A2	06-07-2005
		EP 1704839 A1	27-09-2006
		EP 1925274 A2	28-05-2008
		ES 2222518 T3	01-02-2005
		ES 2231888 T3	16-05-2005
		ES 2252792 T3	16-05-2006
		ES 2326603 T3	15-10-2009

INTERNATIONAL SEARCH REPORT

Information on patent family members

International application No

PCT/US2019/049982

Patent document cited in search report	Publication date	Patent family member(s)	Publication date
		JP 4094063 B2	04-06-2008
		JP 4467645 B2	26-05-2010
		JP 4551423 B2	29-09-2010
		JP 2000515050 A	14-11-2000
		JP 2001522253 A	13-11-2001
		JP 2001522254 A	13-11-2001
		JP 2001522255 A	13-11-2001
		JP 2001522256 A	13-11-2001
		JP 2001522257 A	13-11-2001
		JP 2002509454 A	26-03-2002
		JP 2002510980 A	09-04-2002
		JP 2002510981 A	09-04-2002
		JP 2007260417 A	11-10-2007
		JP 2010088916 A	22-04-2010
		WO 9808442 A1	05-03-1998
		WO 9808445 A1	05-03-1998
		WO 9808446 A1	05-03-1998
		WO 9808447 A1	05-03-1998
		WO 9808448 A1	05-03-1998
		WO 9808449 A1	05-03-1998
		WO 9808450 A1	05-03-1998
		WO 9808451 A1	05-03-1998
		WO 9808452 A1	05-03-1998
		WO 9808453 A1	05-03-1998
		WO 9808479 A1	05-03-1998
<hr style="border-top: 1px dashed black;"/>			
US 5189277	A	23-02-1993	
		AT 126113 T	15-08-1995
		AU 655480 B2	22-12-1994
		DE 69204058 D1	14-09-1995
		DE 69204058 T2	04-01-1996
		EP 0579773 A1	26-01-1994
		JP 3162711 B2	08-05-2001
		JP H06506637 A	28-07-1994
		KR 100259102 B1	15-06-2000
		US 5189277 A	23-02-1993
		WO 9217310 A1	15-10-1992
		ZA 9202543 B	30-12-1992
<hr style="border-top: 1px dashed black;"/>			
US 8917513	B1	23-12-2014	
		US 8917513 B1	23-12-2014
		US 2015102101 A1	16-04-2015
<hr style="border-top: 1px dashed black;"/>			