

(12) STANDARD PATENT
(19) AUSTRALIAN PATENT OFFICE

(11) Application No. **AU 2006231104 B2**

(54) Title
Injection device (adaptable device)

(51) International Patent Classification(s)
A61M 5/145 (2006.01) **A61M 5/24** (2006.01)
A61M 5/20 (2006.01) **A61M 5/32** (2006.01)

(21) Application No: **2006231104** (22) Date of Filing: **2006.03.21**

(87) WIPO No: **WO06/106295**

(30) Priority Data

(31) Number (32) Date (33) Country
0507016.4 **2005.04.06** **GB**

(43) Publication Date: **2006.10.12**

(44) Accepted Journal Date: **2012.04.05**

(71) Applicant(s)
Cilag GmbH International

(72) Inventor(s)
Edington, David;Barrow-Williams, Timothy Donald

(74) Agent / Attorney
Freehills Patent & Trade Mark Attorneys, Level 43 101 Collins Street, Melbourne, VIC, 3000

(56) Related Art
WO 02/056947 A
US 2003/0120212 A1
US 6692469 B1
US 5520653 A

(19) World Intellectual Property Organization
International Bureau



(43) International Publication Date
12 October 2006 (12.10.2006)

PCT

(10) International Publication Number
WO 2006/106295 A1

(51) International Patent Classification:
A61M 5/145 (2006.01)

(21) International Application Number:
PCT/GB2006/001031

(22) International Filing Date: 21 March 2006 (21.03.2006)

(25) Filing Language: English

(26) Publication Language: English

(30) Priority Data:
0507016.4 6 April 2005 (06.04.2005) GB

(71) Applicant (for all designated States except US): **CILAG AG INTERNATIONAL** [CH/CH]; Landis & Gyrstrasse 1, CH-6300 (CH).

(72) Inventors; and

(75) Inventors/Applicants (for US only): **BARROW-WILLIAMS, Timothy, Donald** [GB/GB]; 200 London Road, St. Albans, Hertfordshire AL1 1PL (GB). **EDINGTON, David** [GB/GB]; Apartment 3, Brisbane House, 38 Grosvenor Road, St. Albans, Hertfordshire AL1 3AE (GB).

(74) Agents: **TUNSTALL, Christopher, Stephen** et al.; Carpmaels & Ransford, 43-45 Bloomsbury Square, London WC1A 2RA (GB).

(81) Designated States (unless otherwise indicated, for every kind of national protection available): AE, AG, AL, AM, AT, AU, AZ, BA, BB, BG, BR, BW, BY, BZ, CA, CH, CN, CO, CR, CU, CZ, DE, DK, DM, DZ, EC, EE, EG, ES, FI, GB, GD, GE, GH, GM, HR, HU, ID, IL, IN, IS, JP, KE, KG, KM, KN, KP, KR, KZ, LC, LK, LR, LS, LT, LU, LV, LY, MA, MD, MG, MK, MN, MW, MX, MZ, NA, NG, NI, NO, NZ, OM, PG, PH, PL, PT, RO, RU, SC, SD, SE, SG, SK, SL, SM, SY, TJ, TM, TN, TR, TT, TZ, UA, UG, US, UZ, VC, VN, YU, ZA, ZM, ZW.

(84) Designated States (unless otherwise indicated, for every kind of regional protection available): ARIPO (BW, GH, GM, KE, LS, MW, MZ, NA, SD, SL, SZ, TZ, UG, ZM, ZW), Eurasian (AM, AZ, BY, KG, KZ, MD, RU, TJ, TM), European (AT, BE, BG, CH, CY, CZ, DE, DK, EE, ES, FI, FR, GB, GR, HU, IE, IS, IT, LT, LU, LV, MC, NL, PL, PT, RO, SE, SI, SK, TR), OAPI (BF, BJ, CF, CG, CI, CM, GA, GN, GQ, GW, ML, MR, NE, SN, TD, TG).

Published:
— with international search report

For two-letter codes and other abbreviations, refer to the "Guidance Notes on Codes and Abbreviations" appearing at the beginning of each regular issue of the PCT Gazette.

(54) Title: INJECTION DEVICE (ADAPTABLE DEVICE)

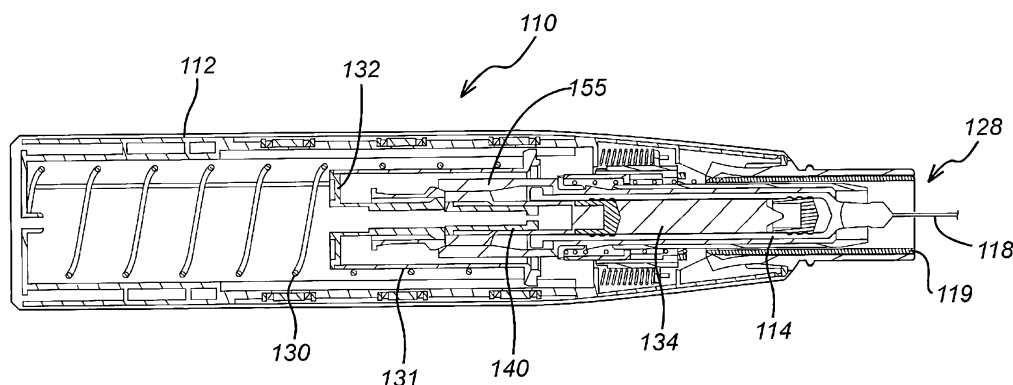

(57) Abstract: An injection device (110) comprises a housing (112) adapted to receive a syringe (116) having a discharge nozzle (118) and a dispensing piston (114) movable in the syringe to expel the contents of the syringe through the discharge nozzle. There is also a drive (130) adapted to act on the syringe to advance it from a retracted position in which the discharge nozzle is contained within the housing to an extended position in which the discharge nozzle extends from the housing. A drive coupling (134) extends from the drive to the dispensing piston of the syringe so as to transfer movement of the drive to the piston. The drive coupling comprises a fixed-length drive coupling and an interchangeable drive coupling. There is also a method of manufacturing an injection device by assembling a first sub-assembly (210) and second sub-assembly (220).



WO 2006/106295 A1

INJECTION DEVICE**5 FIELD OF THE INVENTION**

The present invention relates to an injection device of the type that receives a syringe, extends it, discharges its contents and then retracts it automatically.

10

BACKGROUND OF THE INVENTION

Known injection devices are shown in WO 95/35126 and EP-A-0 516 473 and tend to employ a drive spring and some form of release mechanism that releases the syringe from
15 the influence of the drive spring once its contents are supposed to have been discharged, to allow it to be retracted by a return spring.

Generally, such injection devices require a high force drive spring in order to reliably empty the syringe in the time before retraction of the syringe. When the drive spring is
20 first released, the spring first takes up clearance in the syringe, then extends the syringe and needle and then delivers the drug. The spring force is significantly higher than that required for these initial steps and excess energy is liberated in the form of noise and vibration resulting from recoil of the spring.

25 An injection device can generally operate with a range of syringe fill volumes. When the fill volume is low, there can be substantial clearance to be taken up and hence louder noise and higher recoil on actuation.

It is therefore desirable to minimise the noise and recoil to avoid startling the patient for a
30 range of syringe fill volumes.

SUMMARY OF THE INVENTION

The injection device of the present invention is designed to deal with the aforementioned problem and other issues.

5

In view of the foregoing and in accordance with a first aspect of the present invention, there is provided an injection device comprising:

a housing adapted to receive a syringe having a discharge nozzle and a dispensing piston movable in the syringe to expel the contents of the syringe through the discharge
10 nozzle;

a drive adapted on activation to act on the syringe to advance it from a retracted position in which the discharge nozzle is contained within the housing to an extended position in which the discharge nozzle extends from the housing;

a drive coupling for extending from the drive to the dispensing piston of the syringe
15 so as to transfer movement of the drive to the piston,

characterised in that the drive coupling comprises a fixed-length drive coupling and an interchangeable drive coupling.

By varying the length of the interchangeable drive coupling, the noise and vibration
20 resulting from actuation of the device can be minimised for a given volume of contents in the syringe.

Preferably, the interchangeable drive coupling comprises a rigid member configured to connect with the dispensing piston and with the fixed-length drive coupling.

25

The rigid member has a longitudinal axis.

Advantageously, the quantity of the contents of the syringe which is expelled in use determines the length of the interchangeable drive coupling along its longitudinal axis.

30

Generally, the length of the interchangeable drive coupling is inversely proportional to the quantity of the contents of the syringe.

In one embodiment of the present invention, there is provided an interchangeable release element adapted to disengage the drive from the fixed-length drive coupling after a predetermined amount of movement of the piston.

- 5 Preferably, the interchangeable release element is a constriction adapted to act on at least one arm linking the fixed-length drive coupling to the drive, thereby releasing the drive from the fixed-length drive coupling.

Advantageously, the length of the constriction determines the predetermined amount of
10 movement of the piston.

Generally, the length of the constriction is inversely proportional to the quantity of the contents of the syringe.

- 15 In accordance with a second aspect of the invention, there is provided a method of manufacturing an injection device, comprising:

inserting a syringe having a piston into a first sub-assembly;

inserting an interchangeable drive coupling into the syringe to contact the piston;

providing a second sub-assembly comprising a drive and a fixed-length drive

- 20 coupling; and

assembling the first sub-assembly and second sub-assembly together,

wherein, on assembly, the fixed-length drive coupling and interchangeable drive coupling communicate in use to transfer movement of the drive to the piston.

- 25 Preferably, the interchangeable component has a longitudinal axis and comprises a rigid member configured to connect with the piston and with the drive coupling.

In one embodiment of the present invention, there is the additional step of selecting the interchangeable drive coupling in accordance with its length determined by the quantity of
30 the contents of the syringe.

In a further embodiment of the present invention, there is the further step of connecting an interchangeable release element to the first sub-assembly before the step of assembling,

wherein the interchangeable release element is adapted to actuate after a predetermined amount of movement of the piston a delay mechanism in the drive acting on the fixed-length drive coupling.

- 5 Preferably the injection device further comprises an interchangeable release element adapted to activate after a predetermined amount of movement of the piston a delay mechanism in the drive acting on the fixed-length drive coupling.

10 Preferably, the interchangeable release element is selected in accordance with its length determined by the quantity of the contents of the syringe.

As used herein, except where the context requires otherwise, the term "comprise" and variations of the term, such as "comprising", "comprises" and "comprised", are not intended to exclude other additives, components, integers or steps.

15

Reference to any prior art in the specification is not, and should not be taken as, an acknowledgment, or any form of suggestion, that this prior art forms part of the common general knowledge in Australia or any other jurisdiction or that this prior art could reasonably be expected to be ascertained, understood and regarded as relevant by a person
20 skilled in the art.

BRIEF DESCRIPTION OF THE DRAWINGS

25 The invention will now be described by way of example with reference to the accompanying drawings, in which:

Figure 1 shows a cross-sectional view of an injection device according to the present invention; and

30

Figure 2 shows an enlarged part of the injection device shown in figure 1.

Figure 3 shows an exploded view of components of the injection device according to the

4a

present invention; and

Figure 4 shows a perspective view of sub-assemblies of the injection device according to the present invention.

5

DETAILED DESCRIPTION OF THE DRAWINGS

Figures 1 to 4 show an injection device 110, having an injection device housing 112. The end of the housing 112 has an exit aperture 128, through which the end of a sleeve 119 can emerge.

The housing 112 contains a hypodermic syringe 114 of conventional type, including a syringe body 116 defining a reservoir and terminating at one end in a hypodermic needle

118 and at the other in a flange 120. The syringe body 116 is of substantially constant diameter along the length of the reservoir, and is of significantly smaller diameter close to the end of the syringe which terminates in the hypodermic needle. A drive coupling 134 acts through the bung of the syringe to discharge the contents of the syringe 114 through the needle 118. This drive coupling 134 constrains a drug 124 to be administered within the reservoir defined by syringe body 116. Whilst the syringe illustrated is of hypodermic type, this need not necessarily be so. Transcutaneous or ballistic dermal and subcutaneous syringes may also be used with the injection device of the present invention.

10 As illustrated, the syringe is housed within a syringe carrier 150. The syringe carrier 150 has a proximal end 151 through which the needle 118 of the syringe protrudes. The needle 118 is attached to the syringe body 116 of the syringe by a needle sub-assembly 172 which has a reduced diameter. At the proximal end 151 of the syringe carrier 150, there is a section of reduced diameter 173 which supports the end of the syringe 114 on its body 116.

15 The syringe carrier 150 also includes a pair of flexible projections 152. The pair of flexible projections 152 communicate with a corresponding pair of locking apertures on a return spring support 160 so that the syringe carrier 150 cannot move relative to the return spring support 160. The syringe carrier 150 also comprises a bearing surface 153 close to its second end, against which a corresponding bearing surface of the return spring support 160

20 is biased by a return spring 126. The return spring 126, via the return spring support 160 and the syringe carrier 150 biases the syringe 114 from an extended position in which the needle 118 extends from the aperture 128 in the housing 112 to a retracted position in which the needle 118 is contained within the housing 112.

25 The syringe carrier 150 comprises a sheath 154 into which the syringe 114 can be inserted from a distal end 170. The syringe 114 is provided with a boot (not shown). If the syringe were to fail or break, the sheath 154, which surrounds the syringe 114 along its length, would contain the broken pieces of syringe and reduce the likelihood of them from escaping from the injection device 110.

30

The housing is further provided with a resilient latch member 161 that is biased into a position in which it engages a locking surface 163 on the return spring support 160. Before engaging the locking surface 163, the latch member 161 also extends through a latch

opening 165 in the sleeve 119. The latch member 161 includes a ramped surface 167 against which an edge of the latch opening 165 acts in the manner of a cam acting on a cam follower.

5 The housing also includes an actuator, and a drive which here takes the form of a compression drive spring 130. Drive from the drive spring 130 is transmitted via a multi-component drive to the piston of the syringe 114 to advance the syringe from its retracted position to its extended position and discharge its contents through the needle 118. The drive accomplishes this task by acting directly on the drug 124 and the syringe 114. Static
10 friction between the drive coupling 134 and the syringe body 116 initially ensures that they advance together, until the return spring 126 bottoms out or the syringe body 116 meets some other obstruction (not shown) that retards its motion.

The multi-component drive between the drive spring 130 and the syringe 114 consists of
15 three principal components. A drive sleeve 131 takes drive from the drive spring 130 and transmits it to a drive element 132. This in turn transmits drive to the drive coupling 134 already mentioned.

The drive element 132 includes a hollow stem 140, the inner cavity of which forms a
20 collection chamber 142 in communication with a vent 144 that extends from the collection chamber through the end of the stem 140. The drive coupling 134 includes a blind bore 146 that is open at one end to receive the stem 140 and closed at the other. As can be seen, the bore 146 and the stem 140 define a fluid reservoir 148, within which a damping fluid is contained.

25 A trigger 214 is provided on the housing 112 remote from the exit aperture 128. The trigger, when operated, serves to decouple the drive sleeve 131 from the housing 112, allowing it to move relative to the housing 112 under the influence of the drive spring 130. The operation of the device is then as follows.

30 Initially, the return spring carrier 152, and consequently the syringe carrier 150 and syringe 114, are prevented from movement by the resilient latch member 161. By moving the sleeve 119 in a direction into the housing 112, the edge of the latch opening 165 is brought

into contact with the ramped surface 167 of the latch member 161, causing the latch member 161 to move outwards and thus to disengage from the return spring support 160. Once the latch member 161 has disengaged from the locking surface 163, the syringe is free to move.

5

The actuator is then depressed and the drive spring 130 is released. The drive spring 130 moves the drive sleeve 131, the drive sleeve 131 moves the drive element 132 and the drive element 132 moves the drive coupling 134. The drive coupling 134 moves and, by virtue of static friction and hydrostatic forces acting through the drug 124 to be administered, moves the syringe body 114 against the action of the return spring 126. The syringe body 114 moves the syringe carrier 150, which in turn moves the return spring support 160 and compresses the return spring 126. The hypodermic needle 118 emerges from the exit aperture 128 of the housing 112. This continues until the return spring 126 bottoms out or the syringe body 116 meets some other obstruction (not shown) that retards its motion. Because the static friction between the drive coupling 134 and the syringe body 116 and the hydrostatic forces acting through the drug 124 to be administered are not sufficient to resist the full drive force developed by the drive spring 130, at this point the drive coupling 134 begins to move within the syringe body 116 and the drug 124 begins to be discharged. Dynamic friction between the drive coupling 134 and the syringe body 116 and hydrostatic and hydrodynamic forces now acting through the drug 124 to be administered are, however, sufficient to retain the return spring 126 in its compressed state, so the hypodermic needle 118 remains extended.

Before the drive coupling 134 reaches the end of its travel within the syringe body 116, so before the contents of the syringe have fully discharged, flexible latch arms linking the first and drive couplings 132, 134 reach an interchangeable release element 155 connected to the distal end of the syringe carrier 150.

The interchangeable release element 155 is essentially a constriction which moves the flexible latch arms to a position so that they no longer couple the drive element 132 to the drive coupling 134. Once this happens, the drive element 132 acts no longer on the drive coupling 134, allowing the drive element 132 to move relative to the drive coupling 134.

Because the damping fluid is contained within a reservoir 148 defined between the end of the drive element 132 and the blind bore 146 in the drive coupling 134, the volume of the reservoir 146 will tend to decrease as the drive element 132 moves relative to the drive coupling 134 when the former is acted upon by the drive spring 130. As the reservoir 148 collapses, damping fluid is forced through the vent 144 into the collection chamber 142. Thus, once the flexible latch arms have been released, some of the force exerted by the drive spring 130 does work on the damping fluid, causing it to flow through the constriction formed by the vent 144; the remainder acts hydrostatically through the fluid and through friction between the first and drive couplings 132, 134, thence via the drive coupling 134. Consequently, the drive coupling 134 continues to move within the syringe body 116 and the drug 124 continues to be discharged. Losses associated with the flow of the damping fluid do not attenuate the force acting on the body of the syringe to a great extent. Thus, the return spring 126 remains compressed and the hypodermic needle remains extended.

After a time, the drive coupling 134 completes its travel within the syringe body 116 and can go no further. At this point, the contents of the syringe 114 are completely discharged and the force exerted by the drive spring 130 acts to retain the drive coupling 134 in its terminal position and to continue to cause the damping fluid to flow through the vent 144, allowing the drive element 132 to continue its movement.

Before the reservoir 148 of fluid is exhausted, flexible latch arms linking the drive sleeve 131 with the drive element 132 reach another constriction within the housing 112. The constriction moves the flexible latch arms so that they no longer couple the drive sleeve 131 to the drive element 132. Once this happens, the drive sleeve 131 acts no longer on the drive element 132, allowing them to move relative each other. At this point, the forces developed by the drive spring 130 are no longer being transmitted to the syringe 114. The only force acting on the syringe will be the return force from the return spring 126 which acts on the end of the syringe 114 nearest to the needle 118 via the return spring support 160 and the syringe carrier 150. Consequently, the syringe is returned to its retracted position and the injection cycle is complete.

As can be seen from figure 3, the drive coupling 134 comprises a fixed-length drive coupling 134a and an interchangeable drive coupling 134b. The length of the

interchangeable drive coupling 134b can be varied by changing it for a different interchangeable drive coupling. The interchangeable drive coupling 134b includes a cup 234 at its end adjacent the fixed-length drive coupling 134a for receiving a protrusion 235 on the fixed-length coupling 134b.

5

By varying the overall length of the drive coupling 134 by varying the length of the interchangeable drive coupling 134a, the initial start position (before actuation of the trigger) of a proximal end 240 (the end nearest the discharge needle 118 of the syringe 114) of the drive coupling 134 can be varied. Hence, the proximal end 240 can be
10 arranged to have an initial start position as close as possible to the contents of the syringe – i.e. the initial volume of the syringe 114 can correspond substantially to the volume of the syringe contents. This way, the clearances which have to be taken up when the drive 130 is first released can be minimised, thereby reducing noise and recoil in the injection device 110.

15

Hence, a smaller volume of liquid in the syringe requires a longer interchangeable drive coupling 134a.

Since the length of the drive coupling 134 is variable, it follows that the point at which the
20 flexible latch arms no longer couple the drive element 132 to the drive coupling 134 needs to be varied to ensure that the contents of the syringe can be completely discharged. This is done by varying the length of the interchangeable release element 155.

The longer the drive coupling 134 is, the longer interchangeable release element 155 needs
25 to be.

The interchangeable release element 155 is provided with flexible arms 271 for connecting the interchangeable release element 155 to the syringe carrier 150 at cut-outs 281 on the syringe carrier 150.

30

As shown in figure 4, the injection device 110 can be assembled in two sub-assemblies for ease of manufacture.

A first sub-assembly 210 comprises inserting the syringe 114, syringe carrier 150, interchangeable drive coupling 134b and interchangeable release element 155.

A second sub-assembly 220 comprises the housing 112 and drive elements and actuators of
5 the injection device 110, including the fixed length drive coupling 134a.

This way, a decision on the amount of contents to be inserted into the syringe can be made independently of the construction of the drive elements (which are difficult to assemble) because the length of interchangeable drive coupling 134b and interchangeable release
10 element 155 can be varied immediately before final assembly of the complete injection device 110 by combining the first sub-assembly 210 with the second sub-assembly 220.

It will of course be understood that the present invention has been described above purely by way of example and modifications of detail can be made within the scope of the
15 invention.

CLAIMS

1. An injection device comprising:
 - a housing adapted to receive a syringe having a discharge nozzle and a dispensing
 - 5 piston movable in the syringe to expel the contents of the syringe through the discharge nozzle;
 - a drive adapted on activation to act on the syringe to advance it from a retracted position in which the discharge nozzle is contained within the housing to an extended position in which the discharge nozzle extends from the housing;
 - 10 a drive coupling for extending from the drive to the dispensing piston of the syringe so as to transfer movement of the drive to the piston, wherein the drive coupling comprises a fixed-length drive coupling and an interchangeable drive coupling; and
 - the injection device further comprises an interchangeable release element adapted to actuate after a predetermined amount of movement of the piston a delay mechanism in
 - 15 the drive acting on the fixed-length drive coupling.

2. The injection device of claim 1, wherein the interchangeable drive coupling comprises a rigid member configured to connect with the dispensing piston and with the
- 20 fixed-length drive coupling.

3. The injection device of claim 2, wherein the rigid member has a longitudinal axis.

4. The injection device of claim 3, wherein the quantity of the contents of the syringe which is expelled in use determines the length of the interchangeable drive coupling along
- 25 its longitudinal axis.

5. The injection device of claim 4, wherein the length of the interchangeable drive coupling is inversely proportional to the quantity of the contents of the syringe.

- 30 6. The injection device of claim 5, wherein the interchangeable release element is a constriction adapted to act on at least one arm linking the fixed-length drive coupling to the drive, thereby releasing the drive from the fixed-length drive coupling.

7. The injection device of claim 6, wherein the length of the constriction determines the predetermined amount of movement of the piston.
8. The injection device of claim 7, wherein the length of the constriction is inversely proportional to the quantity of the contents of the syringe.
9. A method of manufacturing an injection device, comprising:
inserting a syringe having a piston into a first sub-assembly;
inserting an interchangeable drive coupling into the syringe to contact the piston;
10 providing a second sub-assembly comprising a drive and a fixed-length drive coupling; and
assembling the first sub-assembly and second sub-assembly together,
wherein, on assembly, the fixed-length drive coupling and interchangeable drive coupling communicate in use to transfer movement of the drive to the piston, and
15 characterised by
connecting an interchangeable release element to the first sub-assembly before the step of assembling, wherein the interchangeable release element is adapted to actuate after a predetermined amount of movement of the piston a delay mechanism in the drive acting on the fixed-length drive coupling.
- 20
10. The method of claim 9, wherein the interchangeable component has a longitudinal axis and comprises a rigid member configured to connect with the piston and with the drive coupling.
- 25
11. The method of claim 9 or claim 10, further comprising selecting the interchangeable drive coupling in accordance with its length determined by the quantity of the contents of the syringe.
- 30
12. The method of any one of claims 9 to 11, further comprising selecting the interchangeable release element in accordance with its length determined by the quantity of the contents of the syringe.
13. The injection device of claim 1, substantially as hereinbefore described with

2006231104 20 Mar 2012

reference to the accompanying drawings.

14. The method of claim 9, substantially as hereinbefore described with reference to the accompanying drawings.

5

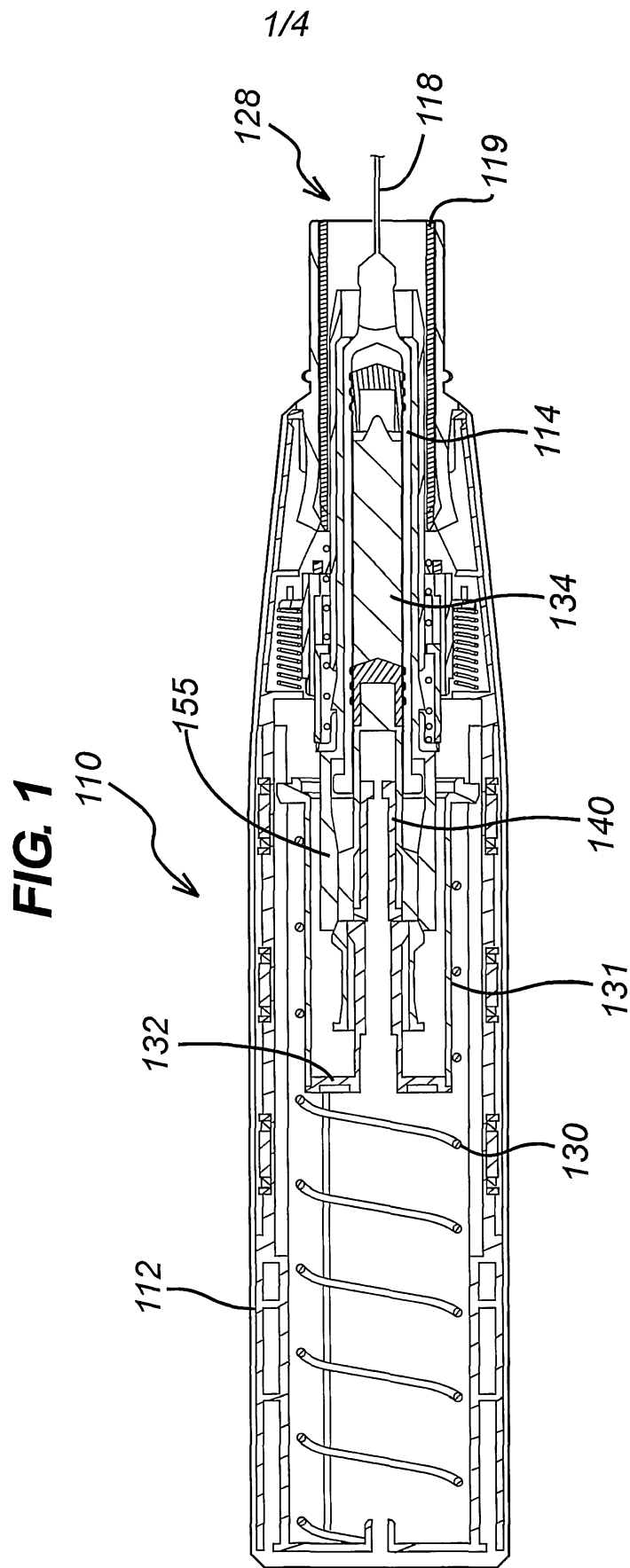
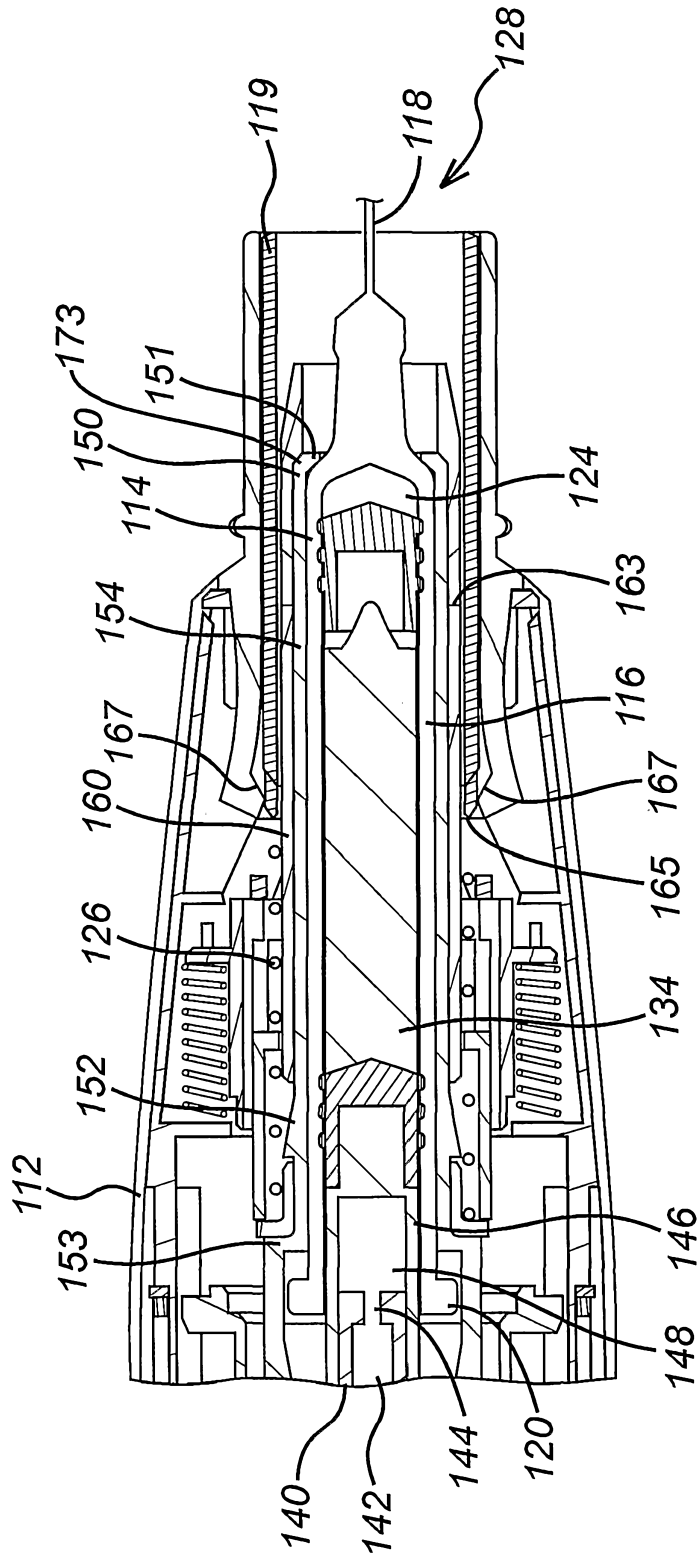

FIG. 2



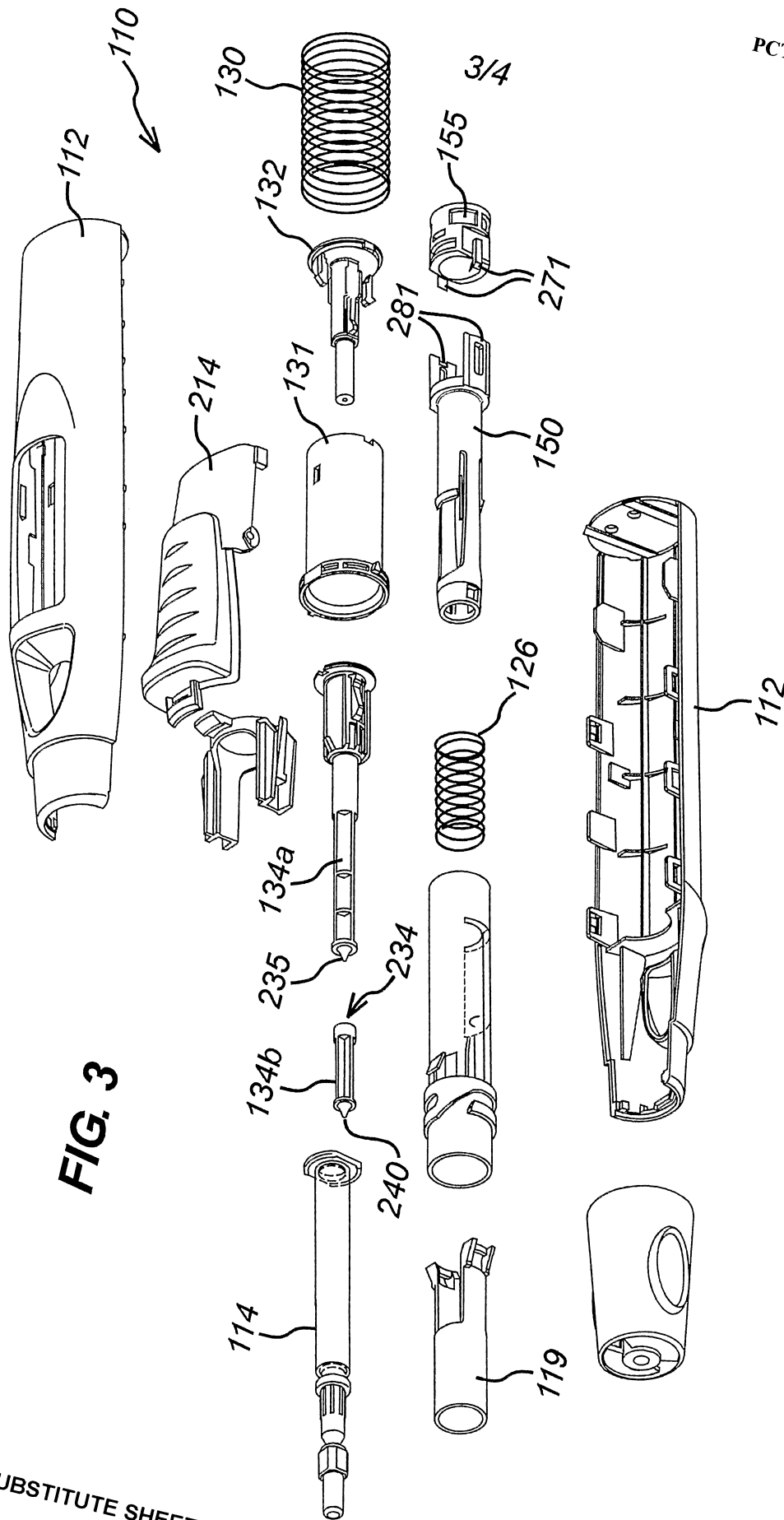

FIG. 3

FIG. 4

