

Jan. 29, 1929.

1,700,355

F. L. FULLER

CALCULATING MECHANISM

Filed Feb. 14, 1918

8 Sheets—Sheet 1

FIG. 1

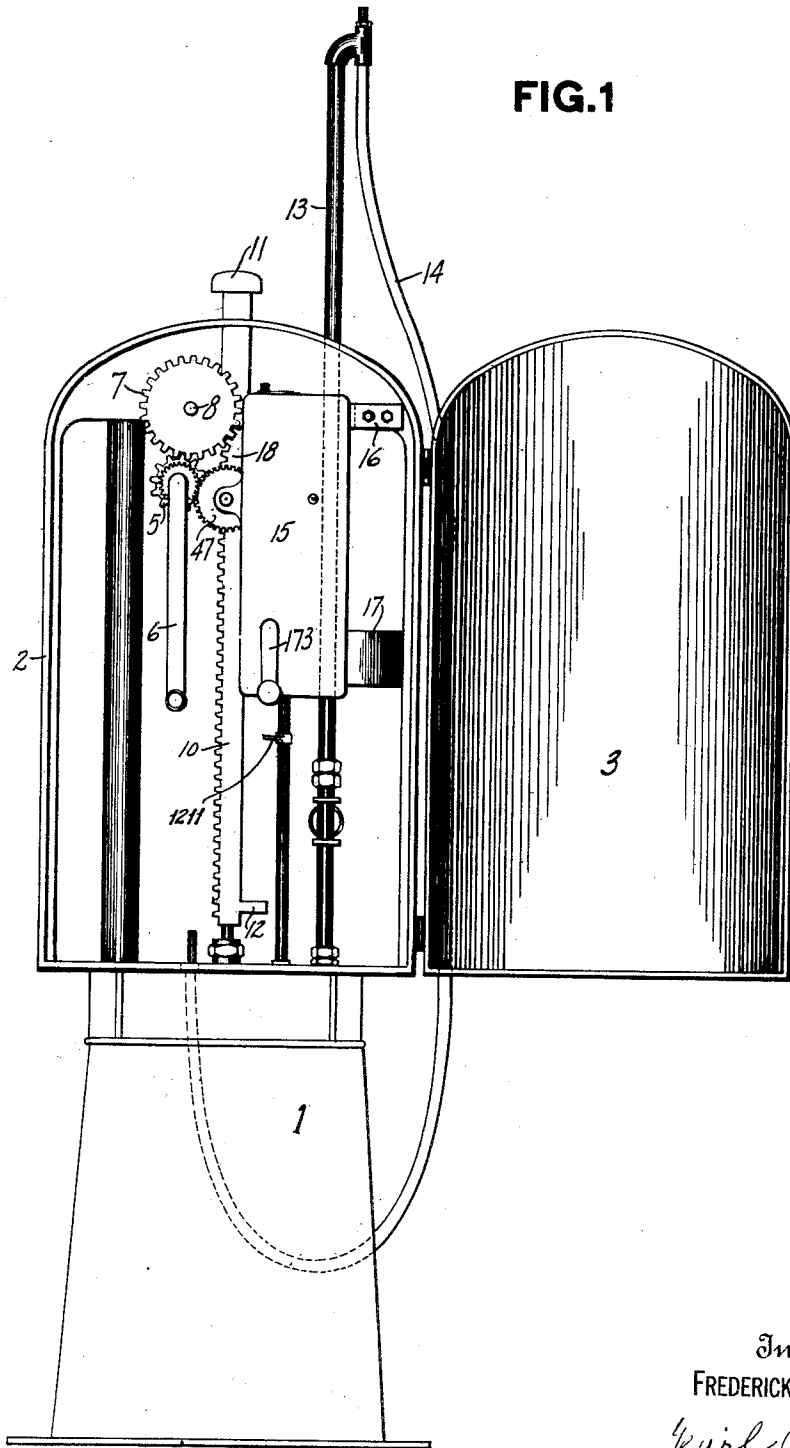

Inventor
FREDERICK L. FULLER
Carl Beust
Attorney

Jan. 29, 1929.

1,700,355

F. L. FULLER

CALCULATING MECHANISM

Filed Feb. 14, 1918

8 Sheets-Sheet 2

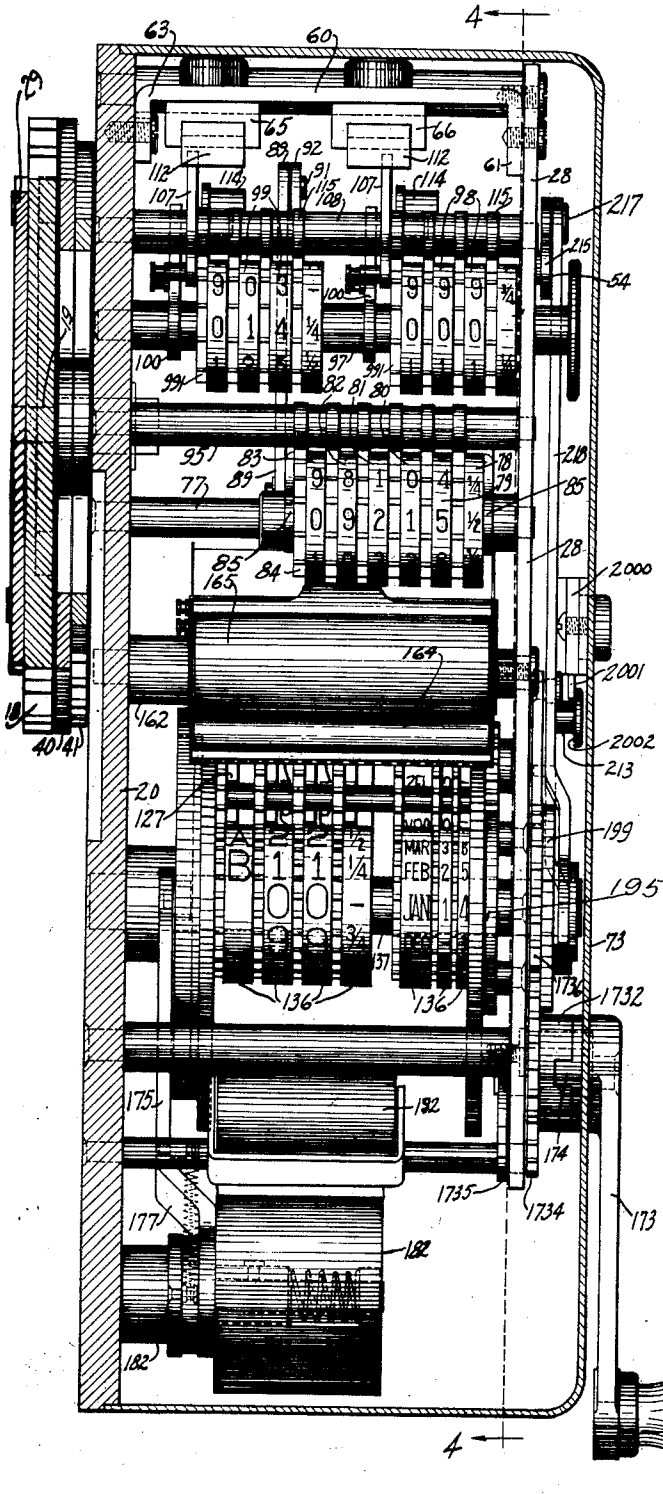

FIG. 2

Inventor
FREDERICK L. FULLER
Carl Beist
Attorney

Jan. 29, 1929.

1,700,355

F. L. FULLER

CALCULATING MECHANISM

Filed Feb. 14, 1918

8 Sheets-Sheet 3

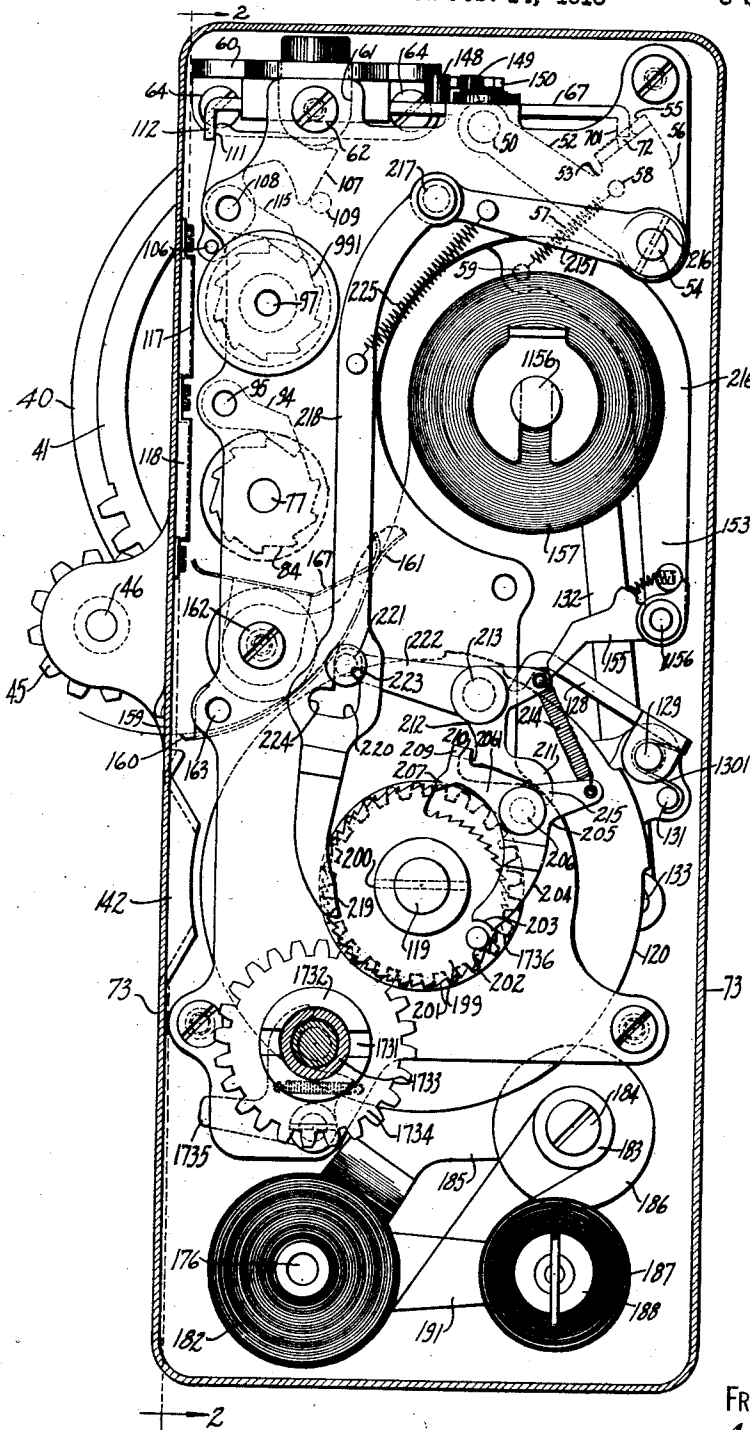

FIG. 3

Inventor
FREDERICK L. FULLER
Carl Beust
Attorney

Jan. 29, 1929.

1,700,355

F. L. FULLER

CALCULATING MECHANISM

Filed Feb. 14, 1918

8 Sheets—Sheet 4

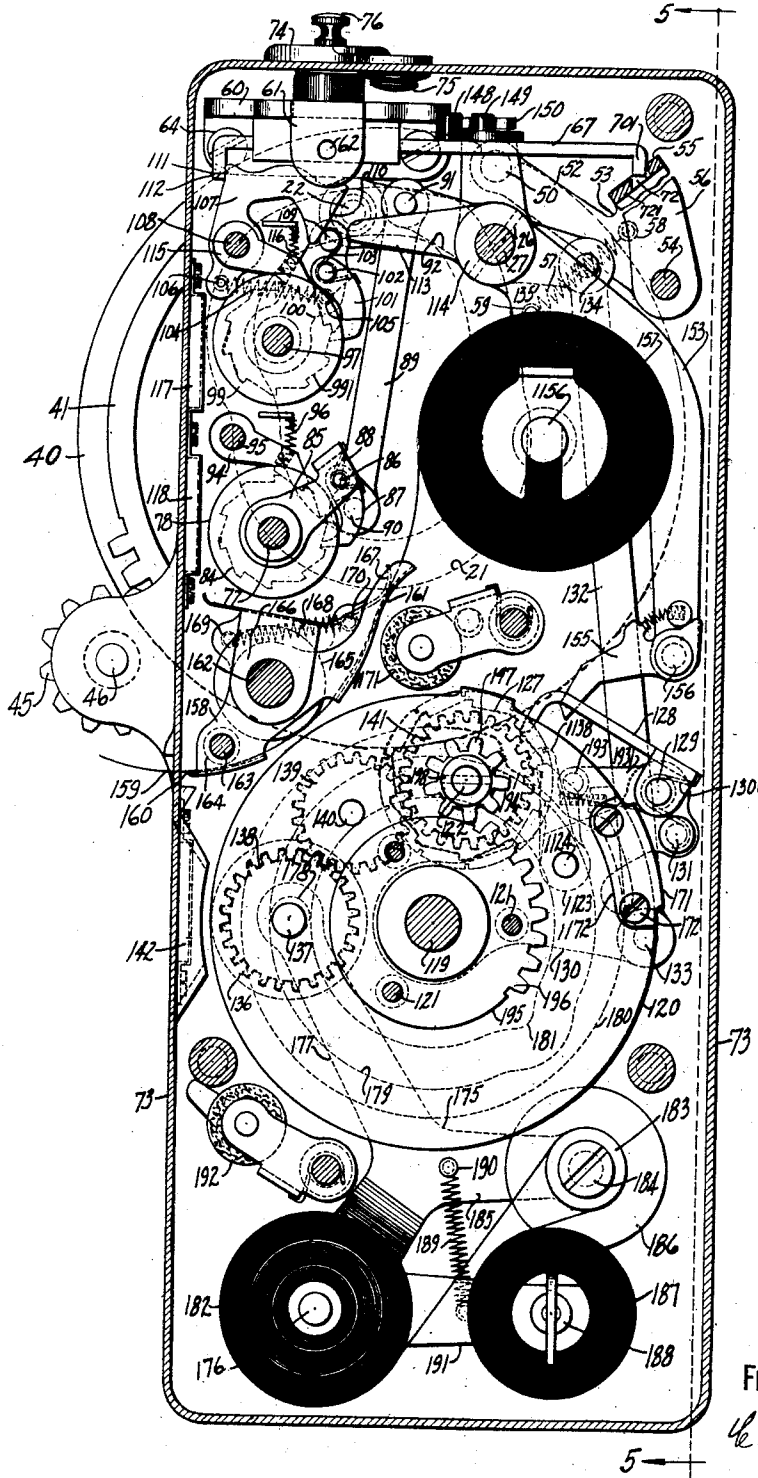

FIG. 4

Inventor
FREDERICK L. FULLER
Carl Beust
Attorney

Jan. 29, 1929.

1,700,355

F. L. FULLER

CALCULATING MECHANISM

Filed Feb. 14, 1918

8 Sheets-Sheet 6

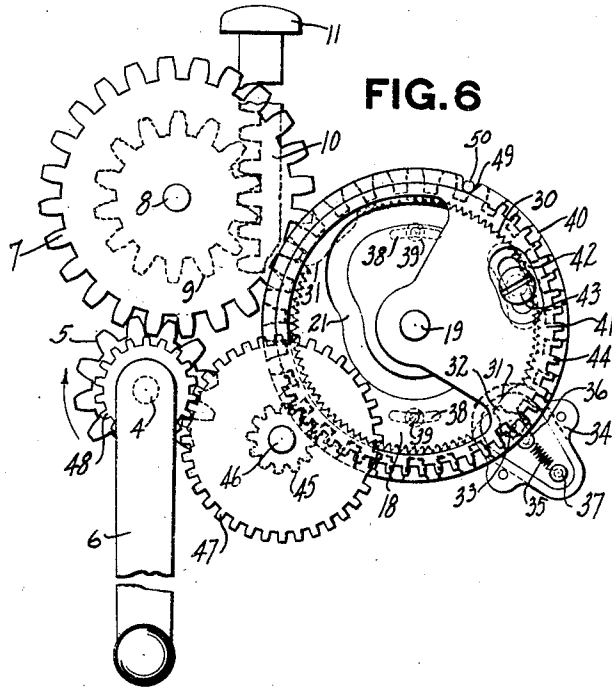

FIG. 6

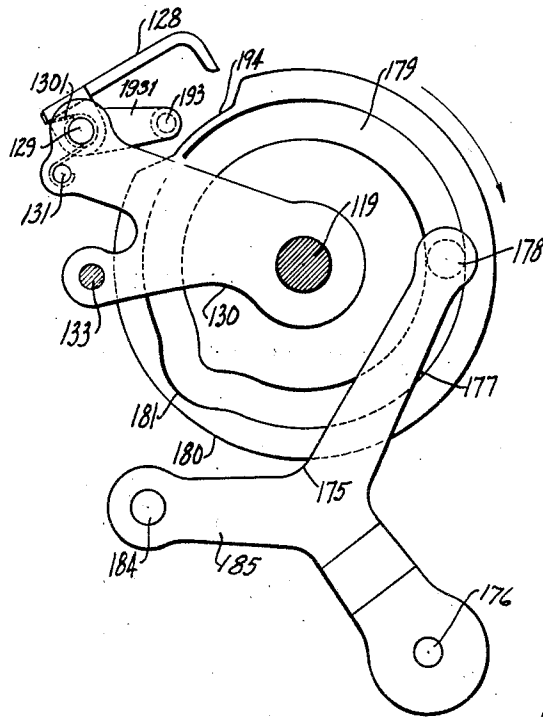

FIG. 7

Inventor
FREDERICK L. FULLER
Earl Beust
Attorney

Jan. 29, 1929.

1,700,355

F. L. FULLER

CALCULATING MECHANISM

Filed Feb. 14, 1918

8 Sheets-Sheet 7

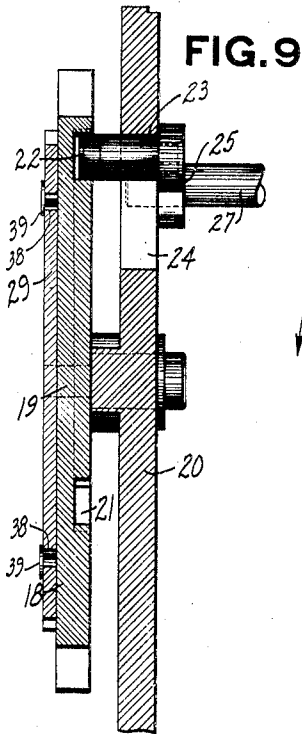

FIG. 9

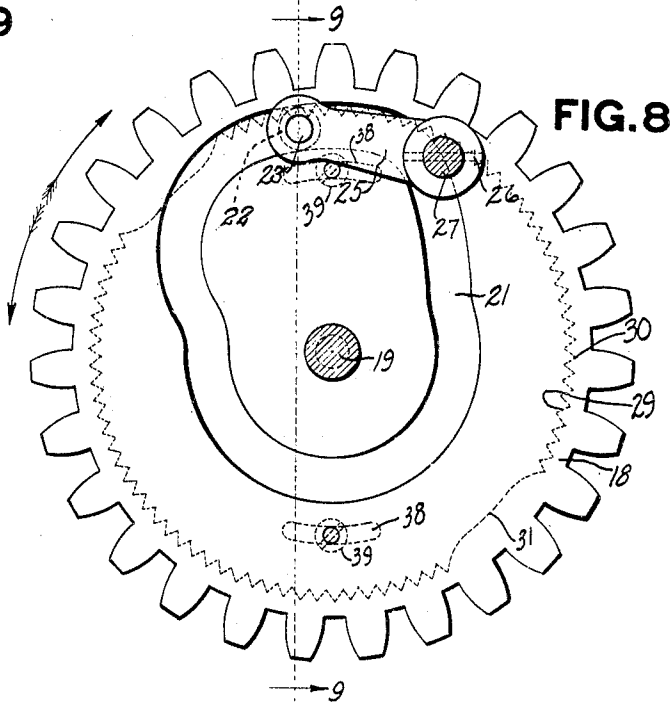

FIG. 8

FIG. 10

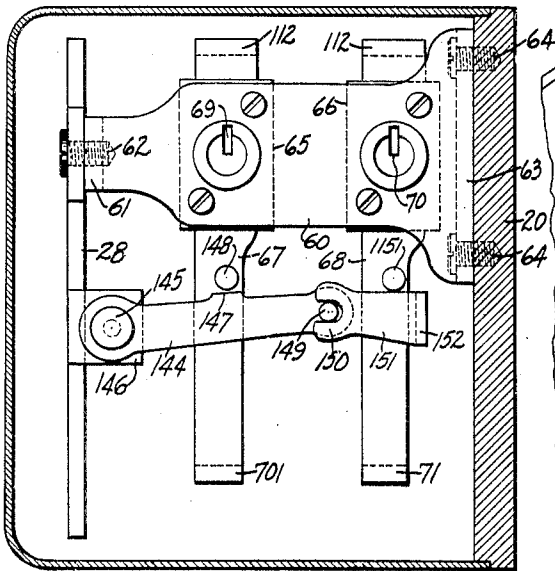
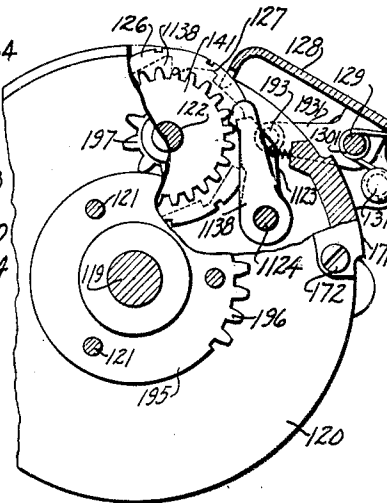

FIG. 14



Inventor
FREDERICK L. FULLER
Earl Beust
Attorney

Jan. 29, 1929.

1,700,355

F. L. FULLER

CALCULATING MECHANISM

Filed Feb. 14, 1918

8 Sheets-Sheet 8

FIG. 11

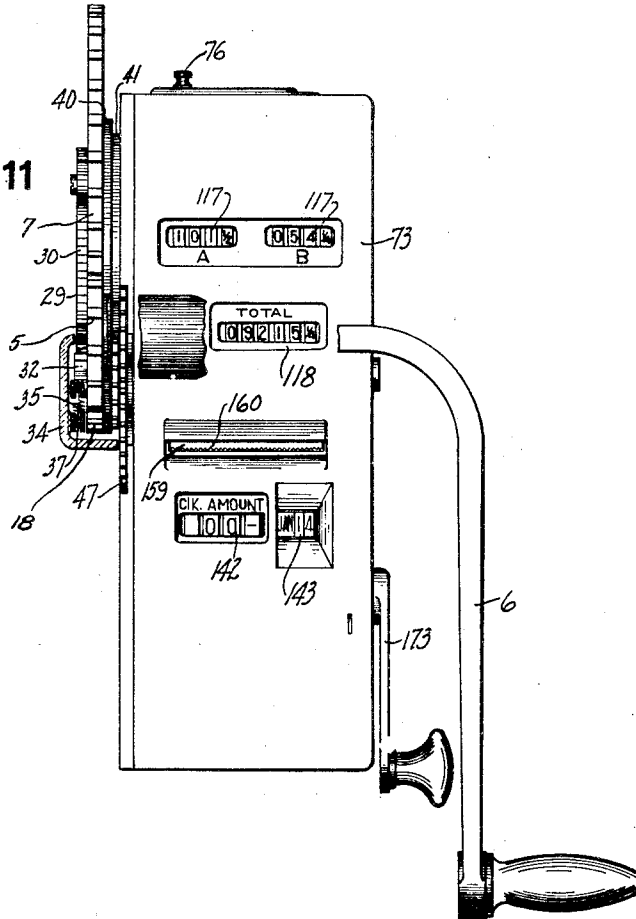

FIG. 13

A	1	4	½
A	0	5	-
B	2	1	-
B	0	0	¼
B	0	8	¾
A	3	7	-
B	1	9	-
B	0	6	-

FIG. 12

YOUR STATEMENT SHOWING THE
CORRECT AMOUNT IN GALLONS
OF YOUR PURCHASE.
HOMESTEAD GARAGE
PHONE 762 146 BROWNST.
A 1 4 ½ JAN 14

Inventor
FREDERICK L. FULLER
Carl Benst
Attorney

UNITED STATES PATENT OFFICE.

FREDERICK L. FULLER, OF BRIDGEPORT, CONNECTICUT, ASSIGNOR, BY MESNE ASSIGNMENTS, TO THE NATIONAL CASH REGISTER COMPANY, OF DAYTON, OHIO, A CORPORATION OF MARYLAND.

CALCULATING MECHANISM.

Application filed February 14, 1918. Serial No. 217,048.

This invention relates to improvements in calculating mechanisms, one object of which is to devise such an apparatus especially adapted for use with fluid dispensing pumps of the well known type used in the vending of gasoline or other fluids, the driving elements of the said calculating mechanism receiving actuation from driving pinions, which comprise the usual operating means for such pumps.

Another object of the present improvement is to provide such a calculating mechanism with means for measuring, registering, and recording in print the amount of fluid dispensed and also means for printing checks commensurate with the amount measured and registered, which checks are given to purchasers as receipts or statements.

Another object of the invention is to provide the calculating mechanism with a plurality of counters which will accumulate separately the amount of fluid sold by the different clerks.

A still further object of the present improvement is to provide a locking means for the pump and also for the calculating mechanism which can only be released by the insertion of keys held by the various clerks. Means is also provided whereby the impression producing mechanism is retained locked until the actuation of the pump, to deliver a predetermined quantity of fluid, is completed. This lock is for the purpose of insuring that a full measure of fluid be dispensed before a receipt therefor can be given the purchaser.

With these and incidental objects in view, the invention consists in certain novel features of construction and combinations of parts, the essential elements of which are set forth in appended claims, and a preferred form or embodiment of which is hereinafter described with reference to the drawings which accompany and form part of the specification.

Fig. 1 is a side elevation of a fluid dispensing pump, the casing being open to show the improved calculating mechanism applied thereto.

Fig. 2 is a front elevation of the calculating mechanism, parts being shown in section taken on the line 2—2 of Fig. 3, looking in the direction of the arrows.

Fig. 3 is a side elevation of the calculating

mechanism showing the lock and release and full stroke mechanisms for the printing elements thereof, parts being shown in section taken on line 3—3 of Fig. 5, looking in the direction of the arrows.

Fig. 4 is a vertical sectional view of the calculating mechanism taken on line 4—4 of Figs. 2 and 5 looking in the direction indicated by the arrows, showing the counters, type wheels, actuating means therefor and the paper feeds.

Fig. 5 is a side elevation of the calculating mechanism taken on line 5—5 of Fig. 4.

Fig. 6 is a rear detail view of the driving connection between the pump actuating gears and the operating gears for the calculating mechanism.

Fig. 7 is a detail view showing the cam and frame for rocking the detail strip platen and also the actuating pawl for the type wheels.

Fig. 8 is a detail view of the main driving gear and actuating arm for the calculating mechanism.

Fig. 9 is a vertical sectional view taken on the line 9—9 of Fig. 8, looking in the direction indicated by the arrows.

Fig. 10 is a detail view of the locks for the different clerks and their connection with the clerks' type setting actuating arm.

Fig. 11 is a front elevation of the registering mechanism, showing the various indicators and the exit opening for the statement strip, the pump actuating handle being partly broken away.

Fig. 12 is a view of a printed check.

Fig. 13 is a fragmentary view of a portion of the printed detail strip.

Fig. 14 is a detail view of the type wheel supporting drum, a portion of the drum being broken away to show the type wheels and their retaining pawls.

Dispensing pumps now in general use, for the vending of gasoline or other fluids, though provided with counters and indicators; provide no positive means for insuring that the purchaser receives the amount of fluid paid for, the only means for ascertaining the amount of fluid pumped being the inspection of the indicator.

In many instances, due to the location of the pump and the dispensing point of the fluid, the measure indicators are not visible to the purchaser and in such cases no way is pro-

vided for assuring that full measure has been given. Such an instance is where gasoline is being sold and the automobilist remains in his car while gasoline is being pumped into the machine tank, and where a long hose is used, the pump and its indicators being either out of sight or so far from the car that a reading of the indicator is impossible. In order to obviate such difficulties and to render it unnecessary for the purchaser to watch the indicator, the present improvement provides a register for the pump, said register having, in addition to the usual counters and indicators, a printing mechanism which is operated commensurate with the amount of fluid dispensed. Printing is done upon a strip, the printed portion of which is severed and given to the purchaser as a statement showing the amount of fluid dispensed. It is then only necessary for the purchaser to be sure that the money paid is correct for the amount of fluid indicated on the receipt, full measure being assured since no other amount of fluid can be pumped than that printed on the statement, or in other words, the statement can show no other amount of fluid than that supplied the customer.

Referring now to the drawings in detail in which like reference numerals designate similar parts throughout the several figures, and referring particularly to Figures 1 and 6, the numeral 1 represents the usual supporting base and 2 the casing of the general type of fluid dispensing pump. The casing 2 is provided with the usual hinged cover 3 which is open whenever the pump is in use. Mounted within the casing 2 upon suitable bearings 4 (see Fig. 6) is a pinion 5 which is rotated by a hand operated crank 6 attached thereto in any suitable manner. Meshing with the pinion 5 is a gear 7 fast upon a shaft 8 rotatably supported within the casing 2, and upon which shaft is also rigidly mounted a pinion 9 meshing with a rack bar 10 the lower end of which is operatively connected to the pump (not shown). The upper end of the rack bar 10 is provided with a cap 11 which is used as a hand engaging means for returning the rack when elevated. Any suitable means, such for example as that shown in Letters Patent of the United States to Meegan, No. 1,172,820, granted Feb. 22, 1916, may be provided to determine the amount of liquid to be dispensed by a throw of the pump piston. This means comprises a vertically extending rod provided with stops 1211, only one of which is shown in Fig. 1, which cooperate with a stop arm 12 on the rack bar 10. (Fig. 1) represents the usual fluid discharge pipe to which the hose 14 is connected in the usual manner.

The improved registering mechanism is carried within a suitable casing 15 secured within the pump casing 2 by means of brackets 16 and 17, the said casing 15 being

so arranged within the casing 2 that the driving means for the register is arranged in operable relation to the pump driving means, as will hereinafter be more fully described. The improved registering mechanism may either be built into and supplied with the dispensing pump or may be sold and applied to pumps already in use as an attachment therefor. The pump casing and operating elements of the pump illustrated in Fig. 1 are of the Gilbert and Barker type and the improved mechanism may be applied to such a pump as an attachment. However, nearly all gasoline dispensing pumps are of the same general design as herein illustrated and it is apparent that the improved registering mechanism may be readily applied thereto by varying the location and size of the brackets 16 and 17 and changing either the driving gears for the register or those for the pump so that they may be in proper ratio to each other.

As explained above the registering mechanism is arranged so as to be driven by the pump actuating mechanism. To this end, the main driving element of the registering mechanism comprises a gear 18, which as shown in Figs. 2, 8 and 9 is rotatably mounted upon a stud 19 supported in one wall 20 of the frame work which supports the various operating elements of the calculating mechanism. The gear 18, as shown in Figs. 6 and 8, is provided on its face adjacent the wall 20 with a cam groove 21. An anti-friction roller 22 is operatively positioned within the said cam groove, the roller being mounted upon one end of a pin 23 which projects inwardly through an opening 24 in the side frame and is mounted on a short arm 25 which is secured by a pin 26 to a shaft 27 having suitable bearings in the front wall 20 and opposite wall 28 of the frame work. The complete rotation or semi rotation and return of the gear 18, through the cam groove 21 roller 22 and arm 25 oscillates the shaft 27. The registering and printing elements of the improved calculating mechanism are operated by the shaft 27, as will be hereinafter fully described, but the taking of the impressions both for the printed check and also the printed record is effected independently of this shaft 27. From the foregoing it will be apparent that when the gear 7 is rotated for operating the pump the gear 18 meshing therewith will also be operated and in this way the elements of the improved calculating mechanism are driven by the pump actuating means. The ratio between the rack 10, gear 7 and gear 18 is such that the latter gear is given two complete rotations during the upward movement of the rack 10 and two complete rotations in the opposite direction during the downward or return movement of the rack 10.

As before explained, the shaft 27 by which certain of the elements of the calculating

mechanism are driven, is oscillated once during one-half of a rotation of the gear 18 in either direction, and for reasons hereafter to be described, it is desirable, when the gear 18 has started to move in either direction, to prevent its movement in the reverse direction until it has made at least one-half a rotation in the direction in which it has started. The means for accomplishing this result is provided by a "full stroke mechanism" which consists of a disk 29 (Figs. 8 and 9) mounted upon the stud 19 and secured to the gear 18 by means hereafter to be described. The outer periphery of the disk 29 is provided with fine teeth 30 and two large notches 31 diametrically opposite each other as is clearly shown in dotted lines on Figs. 6 and 8. A pawl 32 (Fig. 6) pivoted upon a stud 33 carried by a suitable bracket 34 secured to the framework, has its nose normally held perpendicular to the periphery of the disk 29 by means of a coiled spring 35 connecting a tail 36 of the pawl and a stud 37 attached to the bracket 34. The nose of the pawl 32 is arranged to lie adjacent the inner wall of the notch 31 and to be tilted by a movement of the disk 29 and to fit within the fine teeth 30 formed on the periphery of the said disk. When the disk 29 has started to move in one direction, due to the tilted position of the pawl 32 and the fine teeth 30 with which it engages, said disk cannot be moved in the opposite direction until the nose of the pawl 32 reaches the opposite notch 31 at which time it assumes a perpendicular position to the disk and may be then tilted in the opposite direction. Since the disk 29 and gear 18 are connected this "full stroke mechanism" compels a movement of at least one-half a rotation of the gear 18 in either direction in which it is started before it can be reversed.

As previously explained the stroke of the reciprocable rack bar 10 is sometimes varied to regulate the stroke of the pump to which it is attached, and as a consequence the movement of the driving gear 7 is also varied. Since the calculating elements must have a constant unit of movement, the "full stroke mechanism" which effects this constant movement must be varied in accordance with the adjusted movement of the gears 7 and 18. To accomplish this result the disk 29 is provided with slots 38 (Fig. 8) and screws 39 projecting therethrough and threaded into the adjacent side of the gear 18. The slots 38 and screws 39 provide an adjustable connection between the said disk and gear so that they may be adjusted circumferentially relative to each other to compensate for the adjustment of the reciprocable rack bar 10.

It is desirable to normally keep both the pump and calculating mechanism locked against operation so that neither may be operated by an unauthorized person. Since the invention contemplates the use of the appara-

tus by various clerks, a plurality of locks are provided one for each clerk the operation of which not only releases the pump and the calculating mechanism but in addition selects a particular register element and sets a particular type as will be hereinafter explained. This locking mechanism, referring particularly to Figs. 2, 4, 6 and 11 comprises a disk 40 loosely mounted upon the stud 19 to which disk is secured another disk 41 also mounted on said stud, the connection between the two disks comprising a slot 42 in the disk 41 and a set screw 43 passing therethrough and threaded into the disk 40. The disk 41 is provided with gear teeth 44 on a portion of its periphery which teeth mesh with a pinion 45 fast upon a shaft 46 which also has secured thereto a gear 47 meshing with a pinion 48 pinned to the shaft 4, which shaft is rotated by the hand operated crank 6 as previously described. The ratio of this gear train to the teeth 44 on the disk 41 is such that said disk 41 is rotated through approximately 180 degrees and returned during a full movement of the rack bar 10 in either direction. The disk 40 is provided with a notch 49 (Fig. 6), in its periphery within which lies a locking pin 50 carried by the end of one arm 52 (see Fig. 4) of a bell crank lever 53, fast upon a shaft 54, rotatably mounted within suitable bearings formed in the framework. The other arm 521 (Fig. 5), of the bell crank 53, is connected by a horizontally disposed bail 55 to an arm 56 fast upon the shaft 54. A coiled spring 57 stretched between a stud 58 on the bell crank 53 and a stud 59 carried by a lever 153 to be later described, normally holds the pin 50 within the notch 49 in the disk 40. As long as the pin is in this position the disks 40 and 41 are locked against rotation and since the disk 41 meshes with the gear 45, which forms one element of a gear train between the said disk and the pump operating crank 6, the said crank is locked against movement and the operation of the pump prevented. The gear 18 which actuates the elements of the calculating mechanism is also locked against rotation and thus providing a means for locking the said mechanism.

Means is provided for lifting the pin 50 out of the notch 49 in the disk 40 which means may be operated by any one of a plurality of different keys in the custody of the various clerks. This means, referring particularly to Figs. 2, 4 and 10, includes a bracket 60 having a vertically extending flange 61 secured to the wall 28 of the framework by a screw 62. A flange 63 (Figs. 4 and 10) affords means by which said bracket 60 may be secured to the opposite wall 20 of the framework by screws 64. Carried by the bracket 60 are two lock casings 65 and 66 (Figs. 2 and 10) the sliding bolts 67 and 68 of which are operated by keys fitted within key holes 69 and 70 respectively. It is to be understood

that the key required to operate each of the bolts 67 and 68 is different so that each lock requires its own particular key. One end of each of the bolts 67 and 68 is provided with a downwardly extending lip 701 and 71 respectively arranged to cooperate with openings 72 made in the bail 55. When either of the bolts 67 or 68 (referring to Fig. 4) is moved to the right under the operation of a clerk's key the bail 55 is moved to the right thus rocking the arm 52 of the bell crank lever 53 and raising the locking pin 50 out of the notch 49 of the disk 40 and thereby releasing the actuating means for the pump and also the actuating means for the measuring, registering and printing elements of the calculating mechanism.

The openings 72 in the bail 55 are so shaped that when one of the bolts 67 or 68 is moved rearward to rock the arm 56 clockwise to release the registering mechanism the portion 721 (Fig. 4) will pass beneath the end 71 or 701 of the bolt which has not been operated, so that the unoperated bolt will have no effect upon the arm 56. As the arm 56 is rocked clockwise by the operated bolt the portion 721 does not pass beneath the end 71 or 701 of said operated bolt but engages the front edge of the end 71 or 701 so that when the key is turned back to lock the registering mechanism the end 71 or 701 of the operated bolt engages the portion 721 of the bail 55, thereby rocking the arm 56 counter-clockwise to normal position.

The entire calculating mechanism, as shown in Figs. 2 and 5, is enclosed by a removable cabinet or casing 73 forming a portion of the casing 15. A guard plate 74 is pivoted at 75 to the top of the casing 73 and is movable by a handle 76 to expose or conceal the key holes 69 and 70 of the locks 65 and 66.

As previously explained the removal of the pin 50 from the notch 49 in the disk 40 both releases the actuating mechanism for the pump and also releases the gear 18 which is the driving element for actuating the measuring, registering and printing elements of the calculating mechanism. A detailed description of these registering elements together with their cooperation with the pump actuating means through the medium of the gear 18 will now be described.

The pump herein illustrated, to which the improved calculating mechanism is applied is of the type which dispenses one gallon of fluid during a complete reciprocation of the rack bar 10. In practice, however, the amount of fluid dispensed may not always be exactly in gallon units but may be divided into fractions of a gallon such as one-quarter, one-half or three-quarters, in which case the rack bar receives only a short reciprocation, the distance of which depends upon the amount of fluid to be dispensed. The im-

proved calculating mechanism is designed so as to register, record and print gallons and fractions of gallons, the fractions of gallons being based on the unit of one-quarter. Due to this construction any number of gallons or any fraction of a gallon such as one-quarter, one-half or three-quarters may be measured, registered and printed by the calculating mechanism.

A shaft 77 (referring to Figs. 2, 3, 4, and 5) is mounted in the opposite side walls 20 and 28 of the framework and carries rotatably mounted thereon six counter wheels 78, 79, 80, 81, 82 and 83, each of said wheels having fast to its left hand side (as shown in Fig. 2) a ratchet wheel 84. The wheel 78 is designed to register gallons in quarter units and after four steps of movement transfers one unit representing one gallon. Ten actuations of the wheel 79 transfers to the wheel 80, one unit representing ten gallons and so forth on through the counter wheels 81, 82 and 83. The means for actuating the counter wheels and their carrying devices includes two arms 85 (Figs. 2 and 4), each loosely mounted upon the shaft 77 and connected at their outer ends by a bar. Mounted between the arms 85 is rod 86 which has pivoted thereon a six tined pawl 87 the tines of which are normally held in engagement with the teeth of the ratchets 84 by means of a spring 88 coiled about the rod 86, one end of which engages the upper edge of said pawl the other end of which engages said bar. A link 89 has one end pivoted upon a stud 90 carried by one of the arms 85 and its other end pivoted to a stud 91 carried by an arm 92 secured to a hub 93 fixed to the rockable shaft 27. The link 89 so connects the pawl 87 and the rockable shaft 27 that the said pawl is lowered and raised during each oscillation of the shaft 27, the lowering movement of the said pawl rotating the ratchet wheels 84 with which the tines contact. Retaining pawls 94 are pivotally mounted upon a shaft 95 and held in engagement with the ratchet wheels 84 by springs 96 and prevent any retrograde movement of the counter wheels. It requires an up and down movement of the link 89 in order to cause a movement of the counter wheels to register one unit. As previously explained the shaft 27 is rocked either by one complete rotation of the gear 18 or one semi-circular oscillation thereof back and forth before it can be reversed. As a consequence the counter wheels are moved one unit at each rotation of the gear 18 or at one complete semi-circular oscillation of the said gear.

Let us assume now that the operator wishes to dispense a quart of fluid. The pump handle 6 is rotated until the gear 18 has made one-half of a rotation, the handle 6 is then rotated backwards until the gear 18 has made one-half rotation back to normal position. These movements of the handle 6 cause the pump to

dispense one quart of fluid. The first one-half rotation of the gear 18, through the arm 25, shaft 27, arm 92 and link 89, rocks the pawl 87 clockwise around the shaft 77, where-
 5 by the counter wheel 78 is advanced one unit to add one quart. The return movement of the gear 18 raises the link 89 and rocks the pawl 87 counter-clockwise to normal position. Where one-half a gallon of fluid is desired
 10 a complete rotation of the gear 18 in both directions will be necessary. One rotation of the gear 18 will lower and raise the link 89 once and thereby move the counter wheels one unit and upon the return of the crank
 15 6 the gear 18 will receive a complete rotation in the opposite direction, which will again lower and raise the link 89 and move the counter wheels another unit so that when the pump has dispensed one-half a gallon of
 20 fluid and has been returned to its normal position two quart units will have been registered on the counter wheels. If three-quarters of a gallon, one gallon or any number of gallons is desired the pump handle is
 25 turned until the pump has dispensed the desired quantity. During the actuation of the pump handle the gear 18 is rotated and during every rotation thereof or completed semi-circular oscillation thereof, one unit is regis-
 30 tered upon the counter wheels.

As previously explained the "full stroke mechanism" will compel a movement of at least one-half of a rotation of the gear 18 in either direction in which it is started before it
 35 can be reversed. As a result any amount of fluid dispensed by the pump must be in gallons or fractions of gallons and hence the "full stroke mechanism" provides a measure for the pump, each measuring unit being
 40 registered on the counter wheels in the manner here-to-fore described. Since the pump handle can only be reversed at predetermined points, due to the full stroke mechanism, full measure is assured since the dispensing units
 45 cannot be varied and every unit dispensed is indicated and printed for the inspection of the purchaser, as will be hereafter described.

As previously explained the invention contemplates the use of the calculating mechanism by various clerks and it is one of the objects of the invention to provide the mechanism with means for registering separately the amount of fluid dispensed by each clerk. To this end, referring to Figs. 2 and 4, a
 55 shaft 97 is secured in the framework upon which two sets of counter wheels are rotatably mounted, one set comprising counter wheels 98 and the other set counter wheels 99. The wheels of each set are provided with
 60 ratchet wheels 991 secured thereto in a manner similar to that explained in connection with the counter wheels 78 to 83 and ratchets 84. The set of counter wheels 98 is operated independently of the set of wheels 99, each
 65 set being designed as hereafter to be ex-

plained, to register the amount of fluid dispensed by each clerk.

Pivoted upon the shaft 97 are two arms 100, one for each set of counter wheels 98 and 99, to each of which is pivoted a differentially
 70 timed pawl 101 upon a stud 102 around which is coiled a spring 103 bearing against the said pawl and a pin 109 on the arm 100. A coiled spring 104 associated with each counter connects a stud 105 on its respective arm 100 and
 75 a stud 106 secured to one end of a trigger shaped lever 107, pivotally mounted upon a shaft 108 having bearings in the walls 18 and 20 of the framework, there being one of said levers 107 and spring 104 for each clerk's
 80 counter. The spring 104 also serves to hold a pin 109 carried by the upper end of the arm 100 against the inclined nose 110 of the lever 107. A corner 111 of each lever 107 cooperates with a downwardly turned lip 112 integral
 85 with the end of each bolt 67 and 68 opposite to the lips 71 and 701. A movement of one of the bolts 67 or 68 through the lip 112 rocks its associated lever 107 clockwise, and the nose 110 of the said lever rocks its associated
 90 arm 100 clockwise. The clockwise movement of the arm 100 will carry the pawl 101 mounted thereon into contact with the approximately radial side of the teeth on the ratchet wheels 991.
 95

Normally the nose of the pawl 101 occupies the position shown in Fig. 4 in which it is spaced from said radial side of the tooth of the ratchet with which it will cooperate to effect the next unit of registration, in order
 100 to allow the clockwise movement of the arm 100 without moving the ratchet wheel. The rocking of the arm 100 positions its pin 109 beneath the outer end of an arm 113 having a collar 114 fast to the rockable shaft 27,
 105 there being one of said arms for each clerk's counter. When the shaft 27 is rocked by the actuation of the pump the arm 113 is rocked counter-clockwise and then clockwise. The counter-clockwise movement thereof rocks the
 110 arm 100 clockwise through the medium of the pin 109, said pin 109 being held in the path of movement of the lever 113 by means of the lever 107. As previously explained the bolts are actuated by the keys held by the different
 115 clerks and since each set of counter wheels 98 and 99 is provided with a lever 107 which cooperates with one of the bolts 67 and 68, the sliding of either one of these bolts to the right, referring to Fig. 4, for the purpose of
 120 unlocking the pump will also rock the lever 107 associated therewith and select one of the said counters for actuation through the medium of the pin 109 and arm 113 as above described. Retaining pawls 115 pivoted
 125 upon the shaft 108 and held in engagement with the teeth of the ratchets 991 by means of springs 116, prevent any retrograde movement of the ratchet wheels. Each of the clerk's counters is visible through a glass 117
 130

(Fig. 11) and the total counters through a glass 118 secured in the rear of openings made in the casing 73.

The printing means is carried by a rotatable drum comprised of a shaft 119 and two circular plates or disks 120 fast thereto. The shaft is rotatably mounted in the side walls of the framework. The drum carries a shaft 122 secured within the disks 120 adjacent the periphery thereof and rotatably mounted thereon are type wheels 123, 124, 125 and 126 as is best shown in Fig. 5. Type wheel 123 is provided with type indicating one-quarter, one-half and three-quarters, the type wheels 124 and 125 with numerals 1 to 9 and 0 and the wheel 126 with letters A and B. Each of the said wheels has secured to its left hand side, as viewed in Fig. 5, a ratchet wheel 127 (Fig. 14). The wheels 123, 124 and 125 carry from one to the other in a manner well understood by those skilled in the art, as illustrated in the U. S. patent to Thomas Carroll No. 703,639, dated July 1, 1902, but the wheel 126 is operated independently of the former wheels. A differentially timed pawl 128 (Figs. 4 and 5) is pivotally mounted upon a stud 129 secured to a lever 130 loosely mounted upon the shaft 119 and cooperates with the type wheels 123, 124 and 125 with which it is normally held in engagement by means of a spring 1301 engaging the pawl and a stud 131 secured to the lever 130 adjacent the stud 129. Means is provided for rocking the lever 130 and thereby moving the pawl 128 (Figs. 3, 4 and 14) for operating the type wheels. This means comprises a link 132 having one end pivoted to a stud 133 carried by the lever 130 and its other end pivoted to a pin 134 carried by an arm 135 rigidly secured to the rockable shaft 27. From the foregoing it will be seen that when the shaft 27 is rocked to register on one of the clerk's counters and total counter the amount of fluid measured and dispensed, the type wheels 123, 124 and 125 will be correspondingly operated by means of the pawl 128 and type set commensurate with the amount of fluid measured and registered. Spring pressed retaining pawls 1123 (Figs. 5 and 14) are pivoted upon a shaft 1124 and engage the ratchet wheels 127 to prevent retrograde movement thereof.

Means is also provided for visually ascertaining the type set and this means comprises indicators 136 (Figs. 2, 4 and 5) rotatably mounted upon a shaft 137 secured to the disks 120. which indicators are driven in the usual manner by means of gears 138 meshing with gears 139 rotatably mounted upon a shaft 140 secured to the disks 120 of the drum. The gears 139 mesh with gears 141 which receive their movement from the actuation of the type wheels. As a consequence the movement of the type wheels sets the indicators 136 commensurate therewith

and these indicators are visible through an opening covered by a glass 142 set in the casing 73, as is shown in Fig. 11. Spring pressed retaining pawls 1138 (Fig. 14) pivoted upon the shaft 1124 engage the gears 141 and prevent retrograde movement thereof.

Also mounted upon the shaft 122 is a plurality of type wheels 143 carrying characters for printing the date. These wheels are set manually in the usual manner after the casing 73 is removed. It is, of course, to be understood that date indicating wheels are also mounted upon the shaft 137 which are set commensurate with the setting of the date type wheels, the said date indicators being visible through an opening covered by a glass 143 set in the wall of the casing 73, as is shown in Fig. 11.

It has thus far been explained how the insertion of a clerk's key in one of the locks 65 and 66 and the turning of the key so the bolt associated therewith is moved to the right, referring now to Fig. 4, will unlock the pump and will also permit an actuation of the total counter and select a particular clerk's counter 98 or 99 for operation. Means is also provided under the control of the clerk's key for selecting a particular character on the type wheel 126 commensurate with the clerk's counter selected for operation. This means, referring to Fig. 10, includes a lever 144 pivoted upon a stud 145 carried by a horizontally extending bracket 146 secured to the side wall 28 of the framework. The lever 144 is provided with a slightly projecting lip 147 arranged opposite a stud 148 carried by the bolt 67, the other end of the lever 144 being provided with an upstanding pin 149 fitting within the forked end 150 of a lever 151, which normally lies against a stud 1151 carried by the bolt 68, said lever 151 being bent at right angles at the point 152 to form a vertically extending lever 153, as is shown in Figs. 4 and 5, which is pivotally mounted upon the shaft 27. The lower end of the lever 153 carries a spring actuated pawl 155 pivoted upon a stud 156 carried by the said lever. This pawl is arranged to be brought in contact with the ratchet wheel 127 attached to the type wheel 126 for moving it.

The bolts 67 and 68 have the same extent of movement but due to the location of the pivotal connection between the lever 144 and lever 151 the sliding of the bolt 67 will cause a greater movement of the lever 152 than is occasioned by the sliding of the bolt 68. The bolt 68, which causes the smaller movement, will rock the lever 153 sufficient to move the pawl 155 far enough to rotate the ratchet wheel 126 one tooth from its normal position, which will position for printing a certain character thereon, as for instance "B". The sliding of the bolt 67 will move the lever 151 a greater distance and sufficient to cause the

pawl 155 to move the ratchet wheel 127 carried by the special type wheel 126 two teeth, from its normal position, and therefore set up for printing a special character such as "A", it being understood that the type wheel 127 is returned to its normal position at the end of each printing operation, as will be later described. In this way a character is selected on the type wheel 126 in accordance with the bolt 67 or 68 which is operated and as a consequence the printed check and also the printed record will show, not only the amount of fluid dispensed but also the clerk who dispensed it, as will be hereinafter described.

Assuming that the type wheels have been set commensurate with the amount of fluid dispensed and the character type wheel set to print an indication of the clerk who operated the pump, means is provided for taking an impression from the type wheels on a check which is presented to the purchaser as a bill or statement. To this end a paper spool 1156, referring to Fig. 4, of the usual well known form is suitably secured to the framework and contains a supply roll of paper 157 which paper is fed from the roll into a paper chute or guideway 158 and thence out through an opening 159 in the casing 73, as is shown in Fig. 11. The lower edge of the paper chute 158 is provided with a knife 160 providing means for severing the printed portion of the strip as it is extruded from the opening 159. The paper chute 158 comprises a downwardly inclined guide way 161 U shaped in cross section, which is mounted upon rods 162 and 163 secured in the frame work, the rod 163 supporting a guide roller 164 and the rod 162 supporting a platen 165. A paper check or retarding device consisting of a U shaped framework 166 is pivoted to the rod 162 and carries an arm 167 designed to grip the paper between it and the guideway 161. A spring 168 stretched between a stud 169 carried by the framework 166 and a stud 170 carried by the inclined guideway 161 normally holds the arm 167 against the bottom of the said U shaped guideway 161. The paper upon leaving the roll passes beneath the arm 167, under the platen 165 and thence between the guide roller 164 and the bottom of the U shaped guideway 161.

A spring pressed ink roller 1171 is arranged to contact with the type wheels carried by the drum, as the drum moves its wheels into the printing position. The ink roller also contacts an electro-type 171, referring to Fig. 4, which extends across disks 120 of the drum and has depending arms 1172 secured to the outside of each disk 120 by means of screws 172. The electro-type 171 is secured to the said drum at a point in the rear of the type wheels and may contain any printing matter that the proprie-

tor of the business owning the pump may desire. As illustrated in Fig. 12 the electrotype in the present case is designed to print all of the wording on the check illustrated in the said figure except the bottom line.

The means for taking an impression from the type wheels and also the electro-type onto the paper strip from which the check is to be severed includes (referring to Figs. 2 and 3) a crank handle 173 which is arranged outside of the casing 73 and is provided with lugs 174 which project within the said casing and fit within openings 1731 made in the end of a hub 1732, rotatably mounted upon a stud 1733 and secured to a gear 1734. A spring pressed locking arm 1735 provides means for locking the crank handle to the hub 1732 in the usual well known manner. The gear 1734 meshes with a gear 1736 pinned to the shaft 119. After the pump handle 6 has operated the pump and has been returned to normal position, the crank handle 173 is given one complete rotation and thereby through the gears 1734 and 1736 rotating the shaft 119 and carrying the type wheels and electro-type first into contact with the ink roller 1171 and thence into contact with the paper upon the platen 165. The force of the impression between the electro-type and the platen 165 is sufficient to draw the paper through the chute and extrude it from the opening 159 where it may be severed to form a check by the operator pressing the paper against the knife 160.

As previously explained means is provided for printing a permanent record of the amount of fluid dispensed by the pump and this means includes a mechanism for taking a second impression from the type wheels upon a strip of paper which is known in the art as a "detail strip". This second impression device includes a relatively Y shaped lever or framework 175 (Figs. 4 and 7) pivoted upon a shaft 176 secured in suitable bearings in the framework. One arm 177 of the lever 175 carries on its end an anti-friction roller 178 which fits within a cam slot 179 formed in a cam 180 fast to the shaft 119. The cam slot 179 is concentric with the shaft 119 except for one node 181 formed therein the purpose of which will be hereafter described.

A paper supply roll 182 of the usual construction is supported on the shaft 176 from which paper is led and passed over a platen 183 supported upon a stud 184 carried by another arm 185 of the said Y shaped lever 175. Secured to the platen is a friction disk 186 with which a disk 187 carried by a paper storage roll 188 is held in contact by means of a coiled spring 189 stretched between a lug 190 carried by the lever 175 and an arm 191 upon one end of which the storage roll 188 is supported, the other end of the arm 191 being loosely mounted upon the shaft

176. When the crank 173 is turned one complete rotation, in addition to the impression made by the type upon the paper carried by the platen 165 an impression is also made upon the paper carried by the platen 183. The said platen 183 is normally out of the path of movement of the type wheels, as is shown in Fig. 4, but during the rotation of the drum the node 181 of the cam slot 179 rocks the lever 175 and lifts the platen 183 into contact with the type wheels which at that time occupy a position opposite the said platen. The node 181 of the cam slot 179 is of such a shape that after the impression is taken from the type wheels the lever 175 is dropped to its normal position so that the paper carried by the platen 183 will not contact with the electrotype 171. In this way which are printed on the checks issued but no impressions are taken from the electrotype, a portion of this detail strip being shown in Fig. 13. The impression between the platen 183 and the type wheels is sufficient to feed the paper from the supply roll 182 over the platen 183 and on to the storage roll 188, the storage roll receiving a rotation through the friction disks 186 and 187. A spring pressed ink roller 192 is designed to ink the type wheels in advance of their impression upon the paper carried by the platen 183. It is to be understood that the type wheels are prevented from being rotated on their own axes during the time of taking either impression, by means of the spring-pressed retaining pawls 1123, previously described.

Means is provided for holding the type wheel actuating pawl 128 out of the path of the movement of the type wheels during the rotation of the drum. This means comprises an arm 1931 (Figs. 4 and 7) secured to the pawl 128 and carrying an antifriction roller 193 which engages the peripheral edge of the cam 180. While the roller 193 is in contact with the periphery of the cam 180 the arm 1931 is rocked sufficient to throw the pawl 128 out of the path of movement of the type wheels. When the drum occupies its normal position, however, as is shown in Figs. 4 and 7, the actuating pawl 128 is permitted to contact with the type wheels due to a notch 194 formed in the periphery of the cam 180 which permits the roller 193 to drop, thus allowing the pawl 128 to be moved downwardly into engagement with the ratchet wheels 127 of the type wheels.

Since the type wheels must be set up to print the amount of each individual sale, or in other words must indicate the amount of fluid dispensed by the pump for one sale, means must be provided for returning the type wheels to zero after an impression has been made upon the check and upon the detail strip. This means comprises a disk 195

(Figs. 2 and 4) secured to the wall 28 of the framework by means of studs 121. The disk 195 is provided with gear teeth 196 on a portion of its periphery which are adapted to mesh with the teeth of a pinion 197 rigidly secured upon one end of the shaft 122 by a pin 198. When the drum is rotated to take an impression from the type wheels the teeth of the pinion 197 slide around the periphery of the disk 195 and are prevented from being rotated thereby. After the impression of the type wheels on the platen 183 is completed, however, the pinion 197 meshes with the teeth 196 of the disk 195 and is rotated counter-clockwise, which through the medium of the usual turned to zero pawls (not shown) engaging the ratchets 127, will carry all of the type wheels to zero position.

Means is provided for preventing the operation of the crank handle 173 both at the time the pump is locked and also after one of the bolts 67 and 68 has been moved under the actuation of a clerk's key to release the pump and select a clerk's counter and special clerk's type. This locking means, referring to Figure 3, comprises a snail cam shaped disk 199 (Figs. 2 and 3) pinned to the shaft 119 by a pin 200 and provided on its periphery with fine teeth 201. A pin 202 is secured to the disk 199 and said pin cooperates with the curved nose 203 of one arm 204 of a bell crank lever 205 pivotally mounted upon a stud 206 carried by the wall 28 of the framework. The other arm 2061 of the bell crank lever 205 is provided with a pointed nose 207 for engagement with the fine teeth 201 of the disk 199. The arm 2061 is also provided with a horizontally extending lip 209 which normally rests upon a ledge 210 formed on one arm 211 of a bell crank lever 212 pivoted to a stud 213 carried by the wall 28 of the framework. A coiled spring 214 stretched between the bell cranks 212 and 205 normally holds a nose 215 carried by the lower end of the arm 211 of the bell crank 212 against the stud 206 thereby holding the ledge 210 in position to support the lip 209. This arrangement of the parts also positions the curved nose 203 of the arm 204 in the path of movement of the pin 202 so that should an attempt be made to rotate the crank handle 173 the pin 202 would abut the nose 203 and prevent the operation thereof.

When the pump is unlocked by means of the clerk's key, the release for the operating handle 173 is set but the crank handle is not released. This setting means comprises an arm 2151 (Fig. 3) pinned to the shaft 54 by a pin 216 and carrying on its outer end a stud 217 to which is pivoted one end of a link 218 the other end of which is provided with a nose 219 which is adapted to cooperate with the pin 202 in a manner hereafter to be described. The link 218 is also provided with an L shaped slot 220 within which an

anti-friction roller 221 is operatively mounted, said roller being carried by the end of an arm 222 forming part of the bell crank lever 212. The parts are shown in Fig. 3 in their normal positions and before the pump has been unlocked by one of the clerk's keys. In this normal position the roller 221 is in the vertical portion 223 of the L shaped slot 220. When one of the clerk's keys is inserted and turned its bolt is moved to the right carrying with it the bail 55 and rocking the shaft 54, as has been heretofore described. The rocking of the shaft 54 will raise the link 218 and cause the roller 221 to occupy a position opposite the horizontal portion 224 of the said slot. When the roller 221 reaches this position a coiled spring 225 stretched between the link 218 and link 2151 will move the lower end of the link 218 to the right so that the horizontal portion 224 of the slot 220 embraces said roller 221. At this time the release for the operating crank 173 may be said to be set.

To operate the release, the clerk's key is turned in the opposite direction which returns the bolt to its original position, as shown in Fig. 3, which rocks the shaft 54 counter-clockwise forcing the link 218 downwardly. The downward movement of the link 218, through the medium of the roller 221 held within the horizontal portion 224 of the slot 220 rocks the bell crank lever 212 counter-clockwise against the tension of the spring 214 disengaging the lip 209 from the ledge 210, the said spring forcing the nose 207 of the bell crank lever 205 into the beginning of the fine teeth 201 of the snail cam. The downward movement of the nose 207 will move the nose 203 of the bell crank lever 205 out of the path of the pin 202. The crank handle 173 may now be given one complete rotation for effecting the printing operations heretofore described.

The operation of the crank handle 173 rotates the disk 199 counter-clockwise the nose 207 of the bell crank 205 riding on the fine teeth 201 of the disk 199. During the rotation of the disk 199 the pin 202 will engage the nose 219 of the link 218 moving the said link clockwise about its pivot 217 and disengaging the roller 221 from the horizontal portion 224 of the slot 220 and permitting the said roller to move upwardly into the vertical portion 223 of the said slot under the action of the spring 214. As the crank handle 173 is moved to complete one rotation, due to the shape of the disk 199, the nose 207 is gradually raised and the lip 209, carried by the lever 205, restored to its normal position where it rests upon the ledge 210. From the foregoing it is seen that after a complete rotation of the crank handle 173 to effect the printing, said crank handle is automatically locked. It is also apparent from the above that a turning of a clerk's key back and forth

is required in order to release the printing means of the mechanism.

Means is provided for locking the casing 73 in position to enclose the mechanism of the register and this means comprises (referring to Fig. 2), a lock 2000 having a bolt 2001 which engages the stud 213 between the arm 222 and a shoulder 2002 formed on the said stud. After unlocking, the lock and casing 73 may be removed and the mechanism of the register rendered accessible.

While the form of mechanism herein shown and described is admirably adapted to fulfill the objects primarily stated, it is to be understood that it is not intended to confine the invention to the one form or embodiment herein disclosed, for it is susceptible of embodiment in various forms all coming within the scope of the claims which follow.

What is claimed is:

1. In a fluid dispensing pump register, the combination of registering and printing elements, actuating means therefor, a device cooperating with said means for locking said registering elements against operation, a normally locked impression taking means, and means for rocking said device in one direction for unlocking said registering elements and for rocking said device in the other direction for locking said registering elements and simultaneously unlocking said impression taking means.

2. In a fluid dispensing pump register, the combination of registering and printing elements, actuating means therefor, a device cooperating with said means for locking the registering elements against operation, a normally locked impression taking means, means for rocking said device in one direction for unlocking said registering elements and for rocking said device in the other direction for locking said registering elements and simultaneously unlocking said impression taking means, and means for automatically locking said impression taking means after an impression has been taken.

3. In a register adapted to be controlled by a fluid dispensing pump having an actuating rack, the combination of a mechanism operated by said actuating rack, comprising registering and printing elements, means cooperating with said mechanism for normally locking the actuating rack and said elements against operation, a normally locked impression taking operating means, means for releasing the actuating rack and said elements, separate means for releasing the impression taking operating means, and a key operated bolt for operating both of said releasing means.

4. In a register adapted to be controlled by a fluid dispensing pump having an actuating rack, the combination of a mechanism operated by said pump actuating rack comprising registering and printing elements,

- impression taking operating means, means cooperating with said mechanism for normally locking the actuating rack and said impression taking operating means against operation, a member movable in one direction for releasing the actuating rack and said mechanism, and movable in a reverse direction for releasing the impression taking operating means.
5. In a register adapted to be controlled by a fluid dispensing pump having an actuating rack, the combination of a mechanism operated by said pump actuating rack comprising registering and printing elements, impression taking operating means, means cooperating with said mechanism for normally locking the pump actuating rack and said mechanism and the impression taking operating means against operation, means for simultaneously releasing the pump actuating rack and said mechanism, and means operable after an operation of the releasing means for the pump actuating rack for releasing the impression taking operating means of said mechanism.
6. In a register adapted to be controlled by a fluid dispensing pump having an actuating rack, the combination of mechanism operated by said actuating rack comprising registering and printing elements, impression taking operating means, means cooperating with said mechanism for normally locking the actuating rack and said mechanism and said impression taking operating means against operation; means for releasing said actuating rack and said mechanism, and separate means for releasing the impression taking operating means and operable only after actuation of the releasing means for the actuating rack and said mechanism.
7. In a register adapted to be controlled by a fluid dispensing pump having an actuating rack, the combination of mechanism operated by said actuating rack comprising registering and printing elements, impression taking operating means, means cooperating with said mechanism for normally locking the actuating rack and said mechanism against operation, means for releasing the actuating rack and said mechanism, means for releasing the impression taking operating means, and means operated upon operation of said last mentioned releasing means for moving said locking means for said rack and said mechanism into locking position.
8. In a machine of the class described, the combination of printing elements, adjusting means for said elements, impression taking mechanism, locking means for normally maintaining said adjusting means and said impression taking means locked, means for unlocking said adjusting means, means for subsequently unlocking said impression taking mechanism and simultaneously locking the adjusting means, and a device for cooperating with said impression taking mechanism whereby said impression taking mechanism will be locked at the end of the operation.
9. In a machine of the class described, the combination of a rotatable drum, type carriers adjustably mounted therein, means for adjusting the type carriers, means for rotating the drum for taking an impression, and means for locking said means against operation until after the type carriers have been adjusted.
10. In a machine of the class described, the combination of a rotatable drum, type carriers adjustably mounted therein, means for adjusting the type carriers, locking means for said adjusting means operable after the type carriers have been adjusted, means for rotating the drum for taking an impression, and means for unlocking said drum and adapted to be operated by said locking means thereby rendering said drum operable only after the type carriers have been adjusted.
11. In a machine of the class described, the combination of a rotatable printing cylinder, adjustable type carriers mounted therein, and a pivoted means mounted adjacent the rotatable member for adjusting the type wheels, said pivoted member being mounted independently of said printing cylinder thereby permitting the cylinder to rotate without moving said pivoted member.
12. In a machine of the class described, the combination of a rotatable printing cylinder, adjustable type carriers mounted therein, actuating pawls mounted independently of said printing cylinder and adapted to engage said type carriers, means for rotating said rotatable printing cylinder for taking an impression from said type carriers, and means for moving said actuating pawls out of the path of the type wheels during the rotation of said rotatable member.
13. In a machine of the class described, the combination of a rotatable printing cylinder, adjustable type carriers mounted therein, actuating pawls mounted independently of said printing cylinder and adapted to engage said type carriers, means for rotating said rotatable member for taking an impression from said type carriers, and means for moving said actuating pawls out of the path of the type wheels during the rotation of said rotatable member.
- In testimony whereof I affix my signature

FREDERICK L. FULLER.