

H. H. BRIDENTHALL, Jr.
Grain-Binding Harvesters.

No. 133,744.

Patented Dec. 10, 1872.

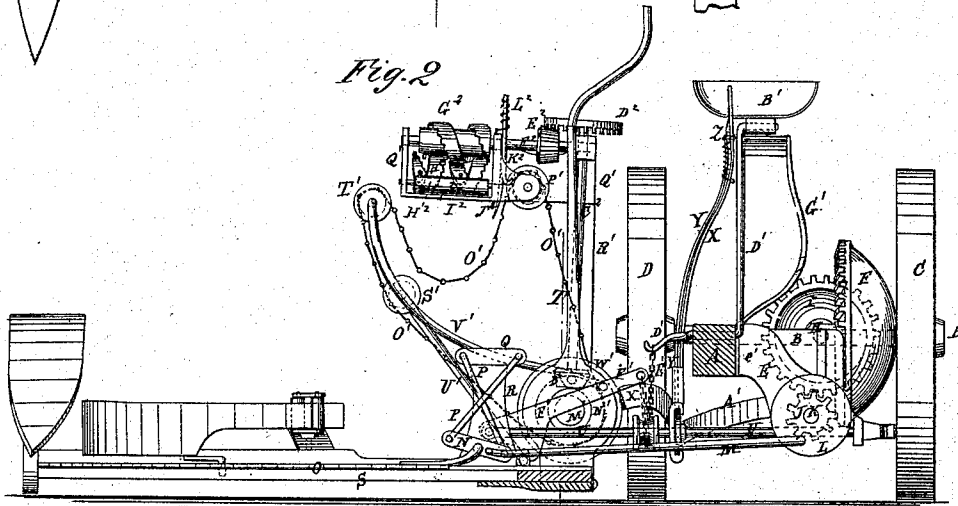
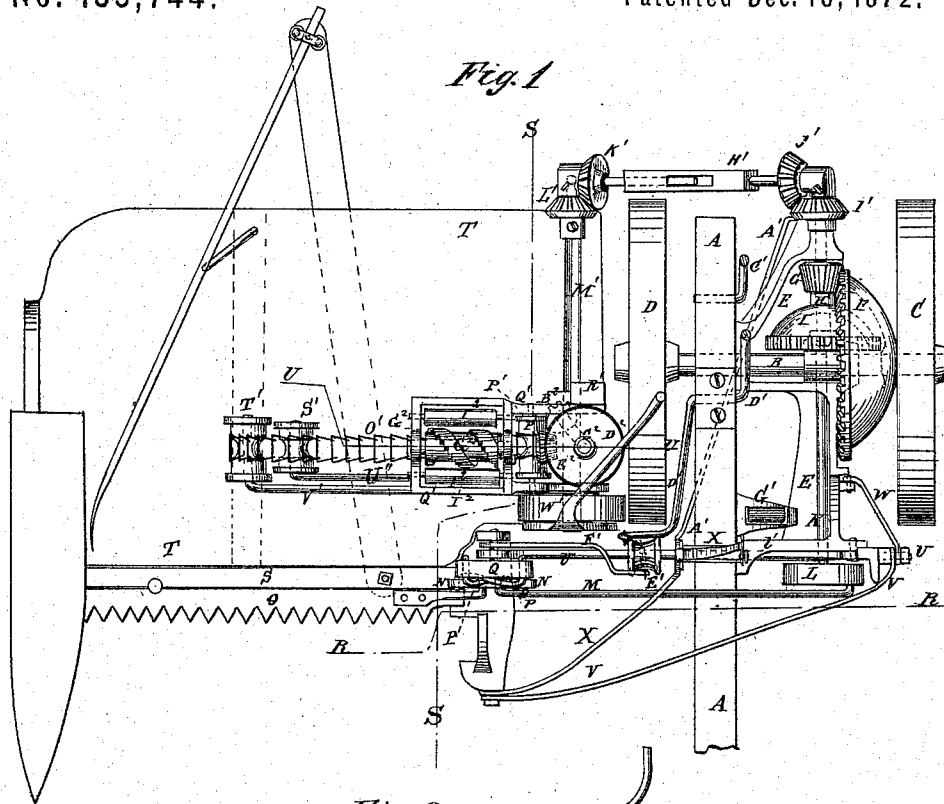

Witnesses:
A. W. Almqvist
C. Sigquist

Inventor:
H. H. Bridenthall Jr

PER *Munnell*
 Attorneys.

H. H. BRIDENTHALL, Jr.
Grain-Binding Harvesters.

No. 133,744.

Patented Dec. 10, 1872.

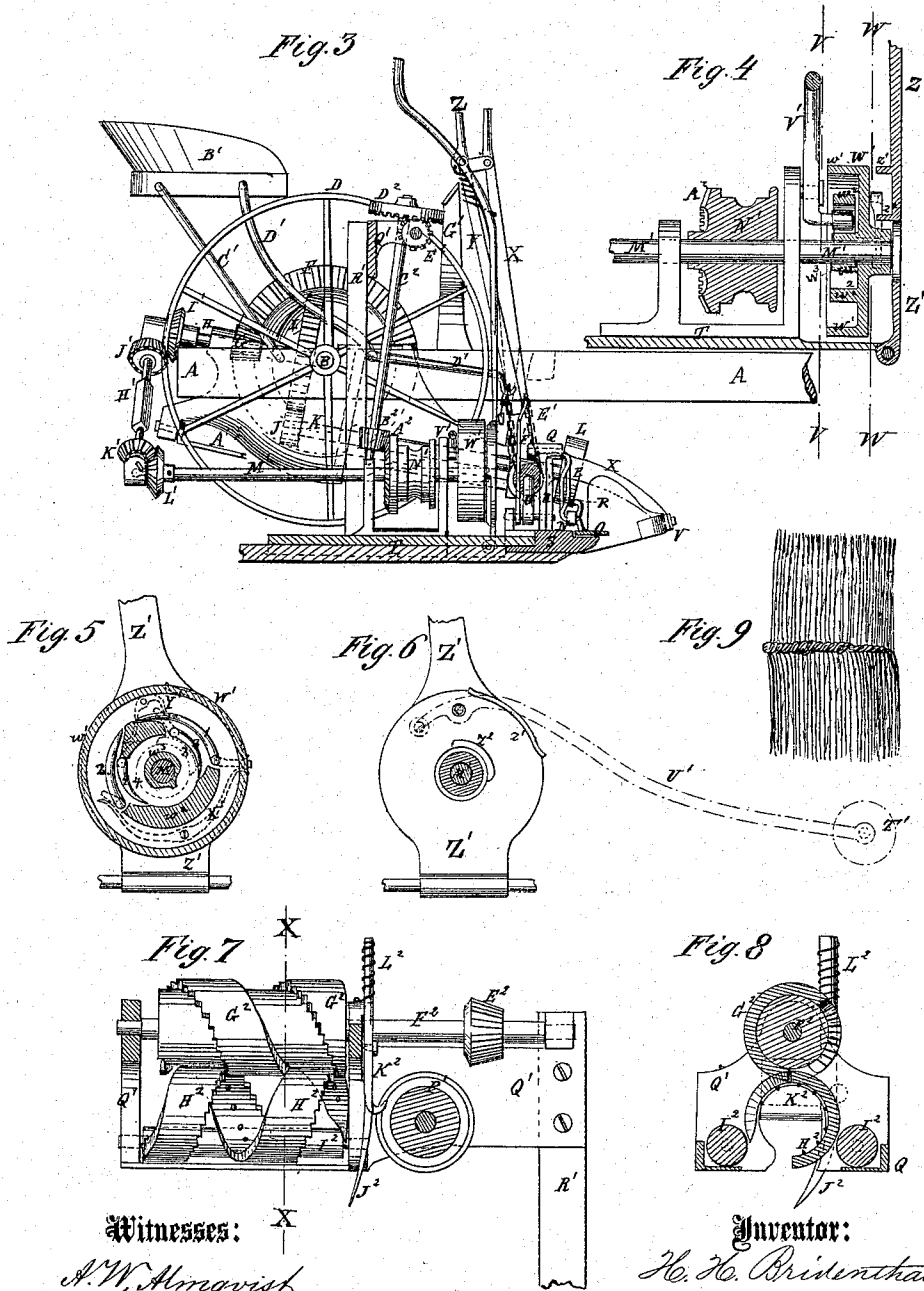

Witnesses:
A. W. Amqvist
C. Sedgwick

Inventor:
H. H. Bridenthall Jr.

per *[Signature]*
 Attorneys.

UNITED STATES PATENT OFFICE.

HARRY H. BRIDENTHALL, JR., OF YOUNGSTOWN, PENNSYLVANIA.

IMPROVEMENT IN GRAIN-BINDING HARVESTERS.

Specification forming part of Letters Patent No. 133,744, dated December 10, 1872.

To all whom it may concern:

Be it known that I, HARRY H. BRIDENTHALL, Jr., of Youngstown, in the county of Westmoreland and State of Pennsylvania, have invented a new and useful Improvement in Harvesters, of which the following is a specification:

Figure 1, Sheet I, is a top view of my improved harvester. Fig. 2, Sheet I, is a front view of the same partly in section through the line R R, Fig. 1. Fig. 3, Sheet II, is a detail section of the same taken through the line S S, Fig. 1. Fig. 4, Sheet II, is a detail section taken through the line T T, Fig. 2. Fig. 5, Sheet II, is a detail section taken through the line V V, Fig. 4. Fig. 6, Sheet II, is a detail section taken through the line W W, Fig. 4. Fig. 7, Sheet II, is a side view of the band-former partly in section through the line U U, Fig. 1. Fig. 8, Sheet II, is a detail cross-section of the same taken through the line X X, Fig. 7. Fig. 9, Sheet II, represents a bundle bound by my machine.

Similar letters of reference indicate corresponding parts.

My invention has for its object to improve the construction of my harvester for which Letters Patent No. 120,027, were issued to me October 17, 1871, so as to make it a self-binder, and otherwise make it more effective in operation; and it consists in the combination of a block, crossed or diagonal rods, and their supports or equivalents with the driving-pitman and sickle-bar; in the combination of the endless chain, chain-wheels, chain pulleys, chain-pulley rods, flanged wheel with its gates and springs, and the flanged lever with each other and with the driving mechanism, for the purpose of raising the gavel into contact with the binding device; in the employment in a grain-binding harvester of a spiral-gear wheel, and a spiral-toothed scroll provided with internally-projecting pins or teeth, for the purpose of twisting bands upon and around the grain-bundles; in the combination of frame, shaft, spiral-gear wheel, spiral-toothed scroll, supporting-rollers, hook, sliding block, and spiral spring with each other, for the purpose of forming a straw band around the gavel while being held and rotated by the endless chain; and in the combination of the lever-chain and lever for raising the cutter-bar with the cutter-bar and with the pivoted seat and

pivoted standard, as hereinafter more fully described.

A represents the tongue, in the rear part of which is a bearing for the axle or driving-shaft B. C is the outer and D is the inner drive-wheel, one of which may be connected with the axle B rigidly, and the other with a pawl-and-ratchet wheel or other clutch, or both may be connected with said axle with pawl-and-ratchet wheels or other clutches. The inner drive-wheel D may be made somewhat larger than the outer drive-wheel C to throw the work of driving the cutters mainly upon the outer wheel and thus counteract the side draft of the machine. E is a box for receiving and protecting the gearing for driving the cutter-bar, the rear part of which is rigidly attached to the tongue A, and its forward part is connected with said tongue by an arm, *e*, cast solid upon said box E. The box E has also lugs cast upon it to receive various arms, rods, and braces. To the driving-shaft B, at the inner side of the outer wheel C, is attached a cup-shaped gear-wheel, F, which enters a recess in the outer side of the box E, and the teeth of which mesh into the teeth of the small gear-wheel G, attached to the short shaft H, placed at right angles to the shaft B, and which works in bearings in the box E. To the shaft H is also attached a large cup-shaped gear-wheel, I, which enters the cavity of the wheel F, and the teeth of which mesh into the teeth of the small gear-wheel J, attached to the rear end of the shaft K, placed parallel with the shaft H, and which revolves in bearings in the lower part of the box E. To the forward end of the shaft K is attached a small crank-wheel, L, to which is pivoted the end of the pitman M that drives the cutter-bars. The outer end of the pitman M is pivoted to the block N, about midway between its center and inner end. To the block N, about midway between its center and outer end, is pivoted the inner end of the sickle-bar O. To the ends of the block N are pivoted the lower ends of the two rods P, which cross each other, and the upper ends of which are pivoted to the ends of the block or cross-head Q, which is of about the same length as the block N, and which is rigidly attached to the upper end of a short stud, R, rigidly attached to the inner end of the cutter-bar S. By this arrangement the sickle-bar O

will work equally well whatever be the inclination of the cutter-bar S and platform T. The cutter-bar S and platform T are connected with the frame-work of the machine by the rod U and brace V. The end of the rod U is pivoted to the cutter-bar S, and the end of the brace V is pivoted to the forward end of a projection or finger formed upon the inner end of said cutter-bar. The outer end of the rod U passes through a projection upon the forward end of the box E, and is secured by a nut. The brace V inclines inward, and its other end is pivoted to the end of the rod U. The ends of the rod U and brace V are further supported by a brace, W, the forward end of which is connected with the end of the rod U and its rear end is bolted to the side of the box E. X is a lever, the end of which is pivoted to the forward end of the finger or guard of the cutter-bar S, to which the brace V is pivoted. The lever X, at its angle, is pivoted to the rod U, and its other end projects upward into such a position that it may be conveniently reached and operated by the driver from his seat to raise and lower the points of the sickles, as may be desired. Y is a bar sliding along the side of the lever X, which is raised and lowered by a small bent spring-lever, Z, pivoted to the upper part of the said lever X. The lower end of the bar Y enters notches in the edge of the rounded forward end of the brace A¹, which is placed upon the rod U at the side of the lever X, and the rear end of which is attached to the rear part of the box E. B¹ is the driver's seat, which is pivoted to the upper end of the standard C¹ the lower end of which is pivoted to tongue A. To the seat B¹ is also pivoted the upper end of the bent lever D¹, which is pivoted at its bend to the tongue A a little in front of the pivoting-point of the standard C¹. The lower arm of the lever D¹ projects forward, and has a hook formed upon its end to enter a link of the chain E¹, which passes around a friction-pulley placed upon the rod U. The end of the chain E¹ is attached to the end of the lever F¹, which is pivoted to the inner end of the cutter-bar S, and has a shoulder formed upon it so that the cutter-bar S may be raised by lowering the said lever. G¹ is a standard rigidly attached to the tongue A, and which has a foot-rest attached to or formed upon its upper end, so that the driver, by resting his foot against the said standard, can force the seat B¹ back to operate the levers D¹ F¹ to raise the cutter-bar and its attachments for passing obstructions, &c. To the rear end of the shaft H is swiveled the end of a shaft, H¹. To the adjacent ends of the shafts H H¹ are attached, respectively, the bevel-gear wheels I¹ J¹, the teeth of which mesh into each other, and which communicate motion from the said shaft H to the said shaft H¹. The shaft H¹ is made in two parts, one of which slides into the other so that the said shaft may accommodate itself in length to the position of the platform T. To the other end of the exten-

sion shaft H¹ is attached a bevel-gear wheel, K¹, the teeth of which mesh into the teeth of the bevel-gear wheel L¹, attached to the end of the shaft M'. The adjacent ends of the shafts H¹ M' are swiveled to each other. By this construction the shaft H¹ serves to communicate motion from the shaft H to the shaft M', and at the same time is supported by the said shafts H M'. The shaft M' revolves in bearings attached to the inner forward part of the platform T, and to its forward part is attached a chain-wheel, N', around which passes the endless chain or band O', which also passes around the pulley P' pivoted to the frame Q', which is rigidly attached to the upper end of the standard R', the lower end of which is securely attached to the rear bearings of the shaft M', or to the platform T. The endless chain or band O' also passes around the chain-pulleys S' T', pivoted, respectively, to the bars U' V'. The lower end of the bar U' is pivoted to the platform T at the inner side of the chain-wheel N', and is designed to keep the pulley S' in place, the said pulley acting as an idler to keep the chain or band O' taut. The bar V' is pivoted to the forward bearing of the shaft M', and upon its end is formed an arm projecting at right angles, which enters a groove in the face of the wheel W', attached to the forward end of the shaft M'. The face of the wheel W' has a continuous flange, w¹, around its outer edge, and a flange, w², between the outer flange and the central core or hub w³. The middle flange w² has two openings formed through it for the passage of the end of the arm V', so that, by allowing said end to pass into the inner space or groove, the roller T' may be raised to raise the gavel to be bound, the upper part of the chain or band O' forming a loop, as shown in Fig. 2, to hold and support the said gavel; and, by allowing said end to pass into the outer space or groove, the roller T' will drop to the platform T, to allow another gavel to be swept by the rake over the rollers T' S' upon the chain or band O' to be raised by the rise of the roller T'. The openings through the flange w² are closed by the two outer gates 1 2 and the two inner gates 3 4. The outer gates are arranged to open in opposite directions, as shown in Fig. 5, and their pivots pass through the wheel W', and have crank-arms formed upon their outer ends, against which rest the ends of a spring X', attached to the wheel W', and which holds the gates 1 2 shut. The inner gates 3 4 open in an opposite direction from each other and from their corresponding gates 1 2, are pivoted to the wheel W', and have cranks formed upon the projecting ends of the said pivots, against which rest the ends of a spring, Y', attached to the wheel W', and which holds the said gates closed. Z' is a lever, the lower end of which is bent inward slightly, as shown in Figs. 3 and 4, and is pivoted to the platform T beneath the forward part of the wheel W' so that the said lever may drop away from the said wheel by its

own weight. The lower part of the lever Z' is enlarged to cover the forward side of the wheel W' , and upon said enlarged part, near its outer edge, is formed a curved flange z^1 , with an inclined forward end, in such a position that when the lever Z' is held up against the wheel W' the said flange z^1 will strike against the crank-pivot of the gate 1 that opens toward the advancing end of the rod V' and open said gate to allow the end of the said rod to pass through, which end forces back the corresponding inner gate 3 and passes into the inner groove, raising the roller T' and the gavel. Upon the lower enlarged part of the lever Z' is formed, near the center of said part, and in such a position as to strike the crank-pivot of the inner gate 4 that opens toward the end of the rod V' when in the inner groove, a curved flange, z^2 , to open the said inner gate 4 and allow the said end of the rod V' to pass out into the outer groove to lower the roller T' and chain or band, O' , to receive another gavel. The upper end of the lever Z' projects into such a position that it may be conveniently reached and operated by the driver from his seat. To the rear end of the chain-wheel N' is attached or upon it is formed a bevel-gear wheel, A^2 , the teeth of which mesh into the teeth of the small bevel-gear wheel B^2 attached to the lower end of the shaft C^2 , to the upper end of which is attached a larger bevel-gear wheel, D^2 . The teeth of the bevel-gear wheel D^2 mesh into the teeth of the smaller bevel-gear wheel E^2 attached to the short shaft F^2 , which revolves in bearings in the frame Q' . The shaft C^2 is slightly inclined forward to bring the shaft F^2 directly over the chain or band O' . To the shaft F^2 , within the frame Q' , is attached a cylinder, G^2 , having a spiral flange formed upon it, making about two turns, and upon the edge of which are formed gear-teeth, thus forming a spiral-gear wheel. H^2 is a spiral-gear scroll similar to the spiral-gear wheel G^2 , into the teeth of which the teeth of the said spiral scroll mesh. The spiral-scroll wheel H^2 is made without any shaft and rests upon and is held in its place by rollers I^2 pivoted to the frame Q' , as shown in Figs. 1, 2, 7, and 8. The spiral-scroll-gear wheel H^2 is kept from longitudinal movement by the ends of the frame Q' , against which the ends of the said wheel H^2 rest. Upon the inner surface of the toothed scroll H^2 are formed internally-projecting pins or teeth, as shown in Figs. 2, 7, and 8, to take hold of the band and twist it as it is passing through said scroll. J^2 is a hook attached to or formed upon the block K^2 , that slides up and down in a groove in the inner end part of the frame Q' , and is held down to its place by a spiral spring, L^2 , placed upon a stem formed upon the upper end of the said sliding block K^2 .

By this construction, as the gavel is raised by the rise of the pulley and rod $T' V'$ it receives a continuous rotary motion from the movement of the endless chain or band O' .

As the gavel revolves the hook J^2 takes up a little of the straw which is caught by the pointed inner end of the spiral scroll H^2 , and twisted while being carried through said scroll, which process, being continued, forms a continuous rope of the straw of the gavel itself. The straw rope, while being formed, rests in a groove of the chain or band O' , the chain-wheels $N' P'$ and pulleys $S' T'$ being grooved accordingly. As the forward end of the rope being formed comes around to the hook J^2 , it passes beneath and raises the sliding block K^2 , which raises the hook J^2 so that it cannot take up any more straw, allowing the ends of the straws already taken up to be twisted in with the rope already formed, making it continuous. The roller T' and arm V' are now lowered, leaving the bundle suspended by its band, which passes through the spiral scroll H^2 . The weight of the bundle now draws down the band so that the pointed forward end of the scroll H^2 passes above said band, and thus runs the scroll out of the band, allowing the bundle to drop.

It will be observed that only the butt ends of the straws are twisted, leaving their heads in place upon the bundle, and unshelled.

Having thus described my invention, I claim as new and desire to secure by Letters Patent—

1. The combination of the block N , crossed or diagonal pivoted rods P and support $Q R$, or equivalent with the driving-pitman M and sickle-bar O , substantially as herein shown and described, and for the purpose set forth.

2. The combination of the endless chain or band O' , wheels $N' P'$, chain-pulleys $S' T'$, rods $U' V'$, flanged wheel $W' w^1 w^2 w^3$, with its gates 1 2 3 4 and springs $X' Y'$, and the flanged lever $Z' z^1 z^2$ with each other, and with the driving mechanism for the purpose of raising the gavel into contact with the binding device, substantially as herein shown and described.

3. In a grain-binding harvester, the spiral-gear wheel, in combination with the spiral-toothed scroll, provided with internally-projecting pins or teeth for the purpose of twisting bands upon and around grain bundles, substantially as herein shown and described.

4. The combination of the frame Q' , shaft F^2 , spiral-gear wheel G^2 , toothed spiral-scroll H^2 , rollers I^2 , hook J^2 , sliding block K^2 , and spring L^2 with each other for the purpose of forming a straw band upon the gavel while being held and rotated by the endless chain or band O' , substantially as herein shown and described.

5. The combination of the lever D^1 , chain E^1 , and lever F^1 , with the cutter-bar S , and with the pivoted seat B^1 , and pivoted standard C^1 , substantially as herein shown and described, and for the purpose set forth.

HARRY H. BRIDENTHALL, JR.

Witnesses:

JNO. B. ANDERSON,
J. H. SCROGGS.