

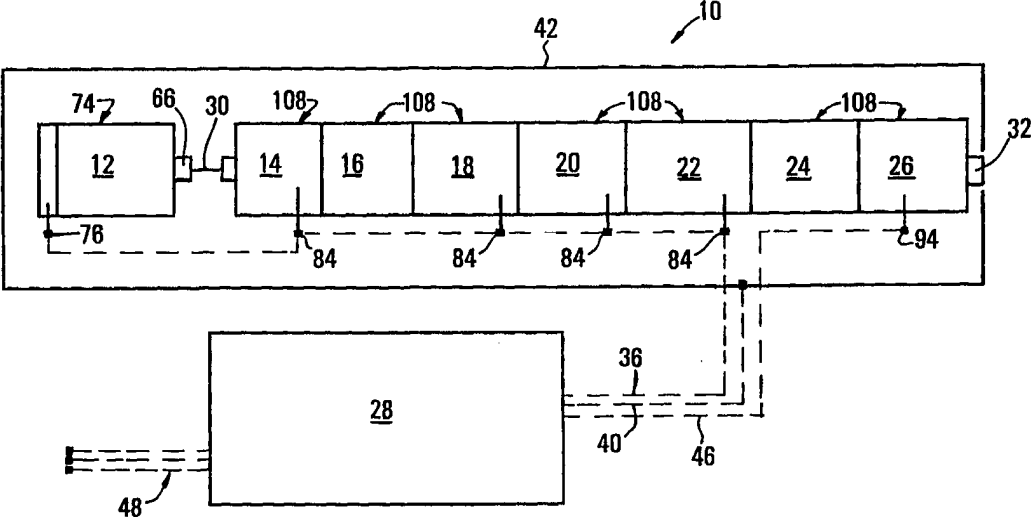

INTERNATIONAL APPLICATION PUBLISHED UNDER THE PATENT COOPERATION TREATY (PCT)

<p>(51) International Patent Classification ⁶ : H04K 3/00, H04B 1/06, 1/10, H04M 11/00, G01S 7/36</p>	<p>A1</p>	<p>(11) International Publication Number: WO 98/18232 (43) International Publication Date: 30 April 1998 (30.04.98)</p>
<p>(21) International Application Number: PCT/US97/14244 (22) International Filing Date: 11 August 1997 (11.08.97) (30) Priority Data: 96/8913 23 October 1996 (23.10.96) ZA (71) Applicant (for all designated States except MW US): DEROPA (PROPRIETARY) LIMITED [ZA/ZA]; 4 Field Road, Lilianton, Boksburg 1459 (ZA). (71) Applicant (for MW only): HANDELMAN, Joseph, H. [US/US]; 26 West 61st Street, New York, NY 10023 (US). (72) Inventors; and (75) Inventors/Applicants (for US only): VALONGO, Paulo, Alexander [ZA/ZA]; 4 Field Road, Lilianton, Boksburg 1459 (ZA). WARD-WATSON, Ernest, Dean [ZA/ZA]; 4 Field Road, Lilianton, Boksburg 1459 (ZA). (74) Agents: HANDELMAN, Joseph, H.; Ladas & Parry, 26 West 61st Street, New York, NY 10023 (US) et al.</p>	<p>(81) Designated States: AL, AM, AT, AU, AZ, BA, BB, BG, BR, BY, CA, CH, CN, CU, CZ, DE, DK, EE, ES, FI, GB, GE, GH, HU, IL, IS, JP, KE, KG, KP, KR, KZ, LC, LK, LR, LS, LT, LU, LV, MD, MG, MK, MN, MW, MX, NO, NZ, PL, PT, RO, RU, SD, SE, SG, SI, SK, SL, TJ, TM, TR, TT, UA, UG, US, UZ, VN, YU, ZW, ARIPO patent (GH, KE, LS, MW, SD, SZ, UG, ZW), Eurasian patent (AM, AZ, BY, KG, KZ, MD, RU, TJ, TM), European patent (AT, BE, CH, DE, DK, ES, FI, FR, GB, GR, IE, IT, LU, MC, NL, PT, SE), OAPI patent (BF, BJ, CF, CG, CI, CM, GA, GN, ML, MR, NE, SN, TD, TG). Published <i>With international search report.</i></p>	

(54) Title: CELLULAR TELEPHONE JAMMING METHOD AND DEVICE



(57) Abstract
A cellular telephone jamming device (10) is provided for jamming cellular telephone communication in a selected zone. The device (10) includes a noise source (12) for generating a noise signal, and transmitter means. The device (10) further comprises first (14), second (18), third (20), fourth (22), and fifth (26) amplification stages, first (16) and second (24) band-pass filters, and a power supply (28). The transmitter means is connected to the noise source (12) and operable to transmit the noise signal in the selected zone. The selected zone is typically a location in a building and the invention extends to a method of disabling a cellular telephone unit in the selected zone.

FOR THE PURPOSES OF INFORMATION ONLY

Codes used to identify States party to the PCT on the front pages of pamphlets publishing international applications under the PCT.

AL	Albania	ES	Spain	LS	Lesotho	SI	Slovenia
AM	Armenia	FI	Finland	LT	Lithuania	SK	Slovakia
AT	Austria	FR	France	LU	Luxembourg	SN	Senegal
AU	Australia	GA	Gabon	LV	Latvia	SZ	Swaziland
AZ	Azerbaijan	GB	United Kingdom	MC	Monaco	TD	Chad
BA	Bosnia and Herzegovina	GE	Georgia	MD	Republic of Moldova	TG	Togo
BB	Barbados	GH	Ghana	MG	Madagascar	TJ	Tajikistan
BE	Belgium	GN	Guinea	MK	The former Yugoslav Republic of Macedonia	TM	Turkmenistan
BF	Burkina Faso	GR	Greece	ML	Mali	TR	Turkey
BG	Bulgaria	HU	Hungary	MN	Mongolia	TT	Trinidad and Tobago
BJ	Benin	IE	Ireland	MR	Mauritania	UA	Ukraine
BR	Brazil	IL	Israel	MW	Malawi	UG	Uganda
BY	Belarus	IS	Iceland	MX	Mexico	US	United States of America
CA	Canada	IT	Italy	NE	Niger	UZ	Uzbekistan
CF	Central African Republic	JP	Japan	NL	Netherlands	VN	Viet Nam
CG	Congo	KE	Kenya	NO	Norway	YU	Yugoslavia
CH	Switzerland	KG	Kyrgyzstan	NZ	New Zealand	ZW	Zimbabwe
CI	Côte d'Ivoire	KP	Democratic People's Republic of Korea	PL	Poland		
CM	Cameroon	KR	Republic of Korea	PT	Portugal		
CN	China	KZ	Kazakstan	RO	Romania		
CU	Cuba	LC	Saint Lucia	RU	Russian Federation		
CZ	Czech Republic	LI	Liechtenstein	SD	Sudan		
DE	Germany	LK	Sri Lanka	SE	Sweden		
DK	Denmark	LR	Liberia	SG	Singapore		
EE	Estonia						

CELLULAR TELEPHONE JAMMING METHOD AND DEVICE

THIS INVENTION relates to cellular telephone communication. It relates in particular to a cellular telephone jamming device for jamming cellular telephone communication and to a method of disabling a cellular telephone unit in a selected zone.

BACKGROUND OF THE INVENTION

In order to effect cellular telephone communication between a cellular station and a cellular telephone unit, bi-directional communication which identifies and enables the cellular telephone unit takes place. When communication with the telephone unit is required, an open or available frequency in a cellular band is then identified and the cellular telephone unit is enabled and communication is then effected. For the purposes of this specification the term "jamming" is intended to include any interference with transmission or reception of cellular telecommunication.

SUMMARY OF THE INVENTION

In accordance with the invention, there is provided a method of disabling a cellular telephone unit in a selected zone, the method including transmitting a jamming signal in the selected zone thereby to prevent communication between a cellular station and the cellular telephone unit.

Typically, the jamming signal interferes with an incoming signal received by the cellular telephone unit. Preferably, the jamming signal operatively interferes with a signature signal transmitted by the cellular station to the cellular telephone unit.

The jamming signal may be a band-limited noise signal.

Further in accordance with the invention, there is provided a cellular telephone jamming device for jamming cellular telephone communication in a selected zone, the device including a noise source for generating a noise signal; and transmitter means connected to the noise source and operable to transmit the noise signal in the selected zone.

Typically, the selected zone is a location in a building, for example, in a bank or the like.

The transmitter means is typically configured to transmit the noise signal in a band of frequencies received by the cellular telephone unit. For example, the band of frequencies may be between about 860 MHz and about 960 MHz.

5 The device may include adjustment means selectively to adjust the power of the noise signal which is operatively transmitted in the selected zone so that the noise signal does not substantially extend into an adjacent zone. Typically, the adjustment means controls the power of the noise signal
10 transmitted from an output stage of the transmitter means.

Preferably, the power of the noise signal which is transmitted in the selected zone is of such a magnitude that the noise signal does not substantially extend into an adjacent zone. As the power of the signal received by the cellular telephone
15 unit is generally lower than the power transmitted by the cellular telephone unit (typically about 2 W), less power is required to be transmitted from the device in order to jam an incoming signal than an outgoing signal and, accordingly, spillage into adjacent zones is thereby reduced.

20 The noise source may be a broad band noise source. Typically, the noise signal is a white noise signal.

The device may include filter circuitry for filtering the noise signal to limit the noise signal to the band of

frequencies received by the cellular telephone unit, e.g. by means of a band-pass filter.

5 The predetermined band is typically between about 860 MHz and 960 MHz. It is however to be appreciated that the predetermined band may vary from country to country depending upon the cellular telephone transmission band used in each particular country. The method may thus include transmitting a jamming signal which comprises a band limited noise signal.

10 The device may include amplification means for amplifying the noise signal. Typically, the device includes a plurality of amplifiers. At least two of the amplifiers may be interconnected by a band-pass filter. Each amplifier may have a gain of about 10 - 20 dB.

15 The transmitter means may include a high frequency cut antenna, or the like.

The invention is now described, by way of example, with reference to the accompanying diagrammatic drawings.

BRIEF DESCRIPTION OF THE DRAWINGS

In the drawings,

Figure 1 shows a schematic block diagram of a cellular telephone jamming device for jamming cellular telephone communication;

Figure 2 shows a schematic circuit diagram of the device of Figure 1;

Figure 3 shows a schematic circuit diagram of a power supply of the device of Figures 1 and 2;

Figure 4 shows a front view of an antenna used in a transmitter of the device;

Figure 5 shows a side view of the antenna of Figure 4;

Figure 6 shows a schematic block diagram of a further embodiment of a cellular telephone jamming device in accordance with the invention;

Figure 7 shows a schematic circuit diagram of certain amplification and filter stages of the device of Figure 6; and

Figure 8 shows a schematic circuit diagram of an output module of the device of Figure 6.

DETAILED DESCRIPTION OF THE DRAWINGS

Referring to the drawings, reference numeral 10 generally indicates a cellular telephone jamming device, in accordance with the invention, for jamming cellular telephone communication in a selected zone or location. The device 10 comprises a noise source 12, a first amplification stage 14, a first band-pass filter 16, a second amplification stage 18, a third amplification stage 20, a fourth amplification stage 22,

a second band-pass filter 24, a fifth amplification stage 26, and a power supply 28 which provides power to the various components of the device 10. The device 10 is operable to transmit a broad band jamming signal into the selected zone thereby to prevent communication between a cellular station (not shown) and a cellular telephone unit (not shown) and thus disable the cellular telephone unit located within the selected zone. The device 10 jams incoming signals from the cellular station.

The noise source 12 generates a noise signal which is fed into the first amplification stage 14 via a co-axial cable 30 and thereafter amplified and filtered and then fed via a jack 32 into a high frequency cut antenna 98 (see Figure 4). The first, second, third, fourth, and fifth amplification stages 14, 18, 20, 22, 26 respectively are each individually screened to reduce external electromagnetic interference. Likewise, the first and second band-pass filters 16, 24 respectively are also screened. The power supply 28 (see Figure 3) has a 12 V DC terminal 34 which is connected via line 36 (see Figure 1) to the various components of the device 10, a ground terminal 38 (see Figure 3) which is connected via line 40 to the various components of the device 10 as well as its casing 42, and a further 12 V DC terminal 44 which is connected via line 46 to the fifth amplification stage 26. Power is fed to the power supply 28 from a mains line 48.

The power supply 28 is conventional in most respects and includes a transformer 50 which has its output rectified by a diode bridge 52. The power supply 28 includes a voltage regulator 54 with its associated circuitry 56 which provides a 12 V DC regulated output at the terminal 34. The power supply 28 further includes a voltage regulator 58 which has associated circuitry 60 and is operable to provide a variable output voltage, typically about 12 V DC, at the terminal 44. The voltage regulators 54 and 58 are mounted on heatsinks (not shown) and the power supply is also screened to reduce interference with the amplification stages 14, 18, 20, 22 and 26 and the band-pass filters 16, 24.

The noise source 12 (see Figure 2) includes a transistor 62 which defines a reversed biased PN junction and is biased to provide a noise signal which is fed via a coupling capacitor 64 to an output terminal 66 of the noise source 12. In order to enhance the noise generated by the transistor 62, a variable resistor 68 is connected via line 70 and a biasing resistor 72 to an emitter of the transistor 62. As mentioned above, the noise source 12 is housed within a screened casing 74 to screen it from external magnetic interference. A positive terminal 76 is connected to line 36 to source power from the power supply 28 and drive the noise source 12. The noise signal generated by the noise source 12 is a white noise signal which covers a frequency band between about 150 MHz and 1200 MHz.

The noise signal is fed from the terminal 66 via the co-axial cable 30 to an input terminal 78 of the first amplification stage 14. The first amplification stage 14 uses an amplification chip 80, typically an INA-10386, and its associated circuitry 82. The first amplification stage 14 is connected via a terminal 84 and via line 36 to the power supply 28. The incoming noise signal fed in via the terminal 78 is fed via a coupling capacitor 86 to the amplifier chip 80 which amplifies the noise signal from about 30 dB μ V to about 50 dB μ V which is then fed via a coupling capacitor 88 into the first band-pass filter 16.

The first band-pass filter 16 filters the noise signal generated by the noise source 12, which is typically between about 150 and 1200 MHz at 30 dB μ V, to a band limited noise signal between about 860 MHz and 960 MHz which is typically the frequency at which a cellular station transmits to a cellular telephone unit. The band limited noise signal is at about 47 dB μ V and is fed via a coupling capacitor 90 into the second amplification stage 18. The second amplification stage 18 resembles the first amplification stage 14 and the same reference numerals have been used to indicate the same or similar components.

The amplified noise signal at the output of the second amplification stage 18 is fed via a coupling capacitor 88 into the third amplification stage 20 which also resembles the first

amplification stage 14 and, accordingly, like reference numerals have been used to indicate the same or similar features. The second amplification stage 18 amplifies the noise signal to about 67 dB μ V and the third amplification stage 20 then amplifies the noise signal to about 87 dB μ V. The noise signal is then fed via line 92 into the fourth amplification stage 22 which, once again, resembles the first amplification stage 14 and like reference numerals have been used to indicate the same or similar features.

The fourth amplification stage 22 amplifies the noise signal to about 107 dB μ V which is then fed via a coupling capacitor 88 into the second band-pass filter 24. The second band-pass filter 24 is similar to the first band-pass filter 16 and filters the noise signal to restrict it to a band of between about 860 to 960 MHz. A slightly attenuated noise signal, typically attenuated by about 3 dB, is fed from the second band-pass filter 24 into the fifth amplification stage 26.

The fifth amplification stage 26 is connected via terminal 94 and via line 46 to the power supply 28. Unlike the first, second, third, and fourth amplification stages 14, 18, 20, and 22, the fifth amplification stage 26 is not based on a single chip 80 but includes discrete components in order to obtain greater output power at its output terminal 32 which is connected to the antenna 98 shown in Figures 4 and 5. The fifth amplification stage 26 is a conventional amplifier and has a gain of about 12 dB μ V thus providing a total gain of the noise signal,

generated by the noise source 12, of about 120 dB μ V. The fifth amplification stage 26 is based on a transistor 100 which includes biasing circuitry 102 and inductors 104 and its output is fed via a coupling capacitor 106 to the terminal 32.

5 Although any suitable antenna may be connected to the terminal 32, the antenna 98 used in the embodiment of the invention illustrated, is a high frequency cut antenna having a reflector 110, a BALUN 112, and dioples 114. The antenna 98 typically has a gain of about 7 dBi and its radiation pattern may vary between about 60 and 90°.

10

Each stage of the circuit is housed in a screened casing 108 to inhibit mutual interference.

Referring to Figures 6 to 8 of the drawings, reference numeral 150 generally indicates a further embodiment of a cellular telephone jamming device in accordance with the invention. The device 150 resembles the device 10 and, accordingly, like reference numerals have been used to indicate the same or similar features unless otherwise indicated.

15

The device 150 comprises four processing modules 152, 154, 156, and 158 which process a white noise signal generated in the processing module 152. A band-limited white noise signal is then fed to an output module 160 (see Figures 6 and 8) via connectors 162 and 164. The output module 160 is connected to

20

a power supply 166 which resembles the power supply 28 but is slightly modified. The power supply 166 includes adjustment means in the form of a variable resistor 168 (see Figure 6) which is adjustable to vary an output voltage on line 170 which is fed
5 to the output module 160.

The processing module 152 includes a noise source 12 (see Figure 7) which generates broad band white noise which is fed into a first band-pass filter 152.1. An output 172 of the first band-pass filter defines an output of the first processing
10 module 152. The second processing module 154 includes a first stage amplifier 14 which feeds its output into a band-pass filter 16. Likewise, the third processing module 156 includes a second stage amplifier 18 and band-pass filter 16, and the fourth processing module 158 includes the third stage amplifier 20 and
15 a band-pass filter 16. Accordingly, the device 150 substantially resembles the device 10 but has been arranged in a modular fashion, and further band-pass filters are provided at the output of the noise source 12 and at the output of the second and third stage amplifiers 18, 20.

20 Referring to Figure 8 of the drawings, the output module 160 differs from the fifth stage amplifier 26 of the embodiment depicted in Figure 2. The output module 160 includes attenuator circuitry 174, and first and second amplifiers 176, 178 respectively, each with a gain of 12 dB. The attenuator
25 circuitry 174 is connected via line 170 to the power supply 166

and is arranged so that, upon adjustment of the variable resistor 168, the gain of the output module 160 is adjusted. Accordingly, the power of the noise signal transmitted by the device 150 may be selectively adjusted.

5 The attenuator circuitry 170 includes two H.P.SMD PIN diodes 180 which are connected to associated circuitry and the input noise signal, from the fourth amplification stage 158, is fed via the PIN diodes 180 and a strip line impedance matcher 182 to the first amplifier 176. The first amplifier 176 is a
10 generally conventional amplifier including a transistor and associated circuitry and its output is fed via a strip line impedance matcher 184 into the second amplifier 178. The second amplifier 178 is similar to the first amplifier 176 and its output is fed via a strip line impedance matcher 186 to an output
15 terminal 188 which is connected to the antenna 98. The output module 160 is mounted in a separate casing to the processing modules 152 to 158 in order to enhance isolation and reduce feedback to the processing modules 152 to 158.

20 In use, the device 10 is typically mounted in a preselected zone such as a location in bank where it may not be desirable for cellular telephone communication to take place. Normally, in order to effect cellular communication between a cellular base station and a cellular telephone unit, a signature signal is sent from the base station to the cellular telephone
25 unit to identify and enable the cellular telephone unit.

However, when the devices 10, 150 are in use, the broad-band noise signal generated by the devices 10, 150 prevents the cellular base station from communicating with the telephone unit and thus it is not possible to enable the cellular telephone unit, e.g. it is not possible for the base station to allocate a particular communication channel to the cellular telephone unit.

As the power of the incoming signal received by the cellular telephone unit is generally considerably lower than the output power transmitted from the cellular telephone unit (typically about 2 W), it is possible to jam the incoming signal using a lower power output from the devices 10, 150 than it would be to jam an outgoing signal from the cellular telephone unit. Accordingly, spillage of the jamming signal generated by the devices 10, 150 to neighbouring or adjacent locations or zones is reduced.

The Applicant believes that the invention, as illustrated, provides a simple yet effective cellular telephone communication jamming device 10, 150 which is operable to prevent use of a cellular telephone unit in a preselected zone.

CLAIMS:

1. A method of disabling a cellular telephone unit in a selected zone, the method including transmitting a jamming signal in the selected zone thereby to prevent communication between a cellular station and the cellular telephone unit.
- 5
2. A method as claimed in Claim 1, in which the jamming signal interferes with an incoming signal received by the cellular telephone unit.
3. A method as claimed in Claim 2, in which the jamming signal operatively interferes with a signature signal transmitted by the cellular station to the cellular telephone unit.
- 10
4. A method as claimed in Claim 1, in which the jamming signal is a band-limited noise signal.
5. A cellular telephone jamming device for jamming cellular telephone communication in a selected zone, the device including a noise source for generating a noise signal; and transmitter means connected to the noise source and operable to transmit the noise signal in the selected zone.
- 15
6. A device as claimed in Claim 5, in which the transmitter means is configured to transmit the noise signal in a band of frequencies received by the cellular telephone unit.
- 20

7. A device as claimed in Claim 6, in which the band of frequencies is between 860 MHz and 960 MHz.

8. A device as claimed in Claim 6, which includes adjustment means selectively to adjust the power of the noise signal which is operatively transmitted in the selected zone so that the noise signal does not substantially extend into an adjacent zone.

9. A device as claimed in Claim 6, in which the noise source is a broad band noise source.

10. A device as claimed in Claim 9, in which the noise signal is a white noise signal.

11. A device as claimed in Claim 6, which includes filter circuitry for filtering the noise signal to limit the noise signal to the band of frequencies received by the cellular telephone unit.

12. A device as claimed in Claim 11, which includes amplification means for amplifying the noise signal.

13. A device as claimed in Claim 12, in which the device includes a plurality of amplifiers, at least two of the amplifiers being interconnected by a band-pass filter.

14. A device as claimed in Claim 5, in which the transmitter means includes a high frequency cut antenna.

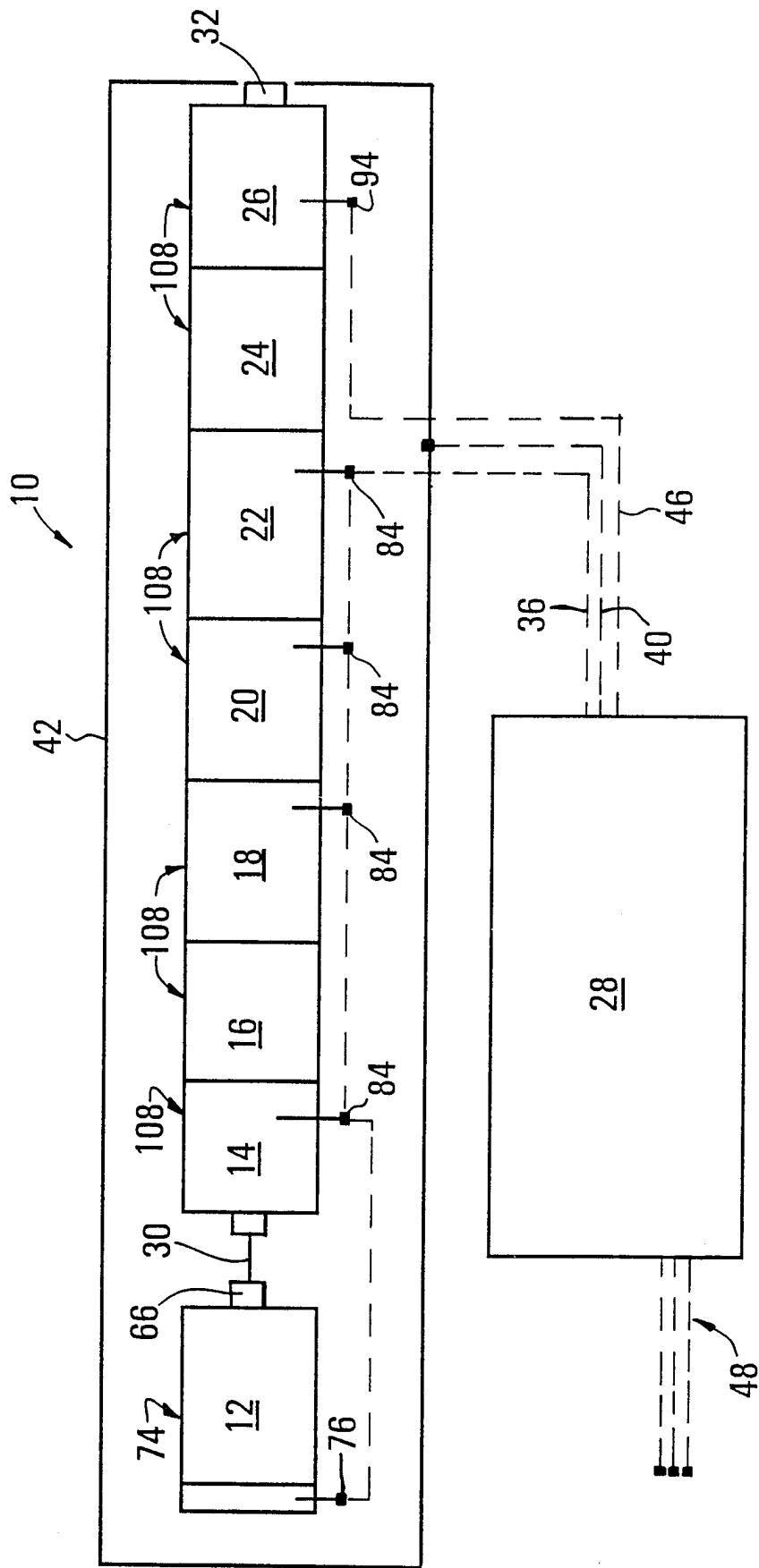

FIG 1

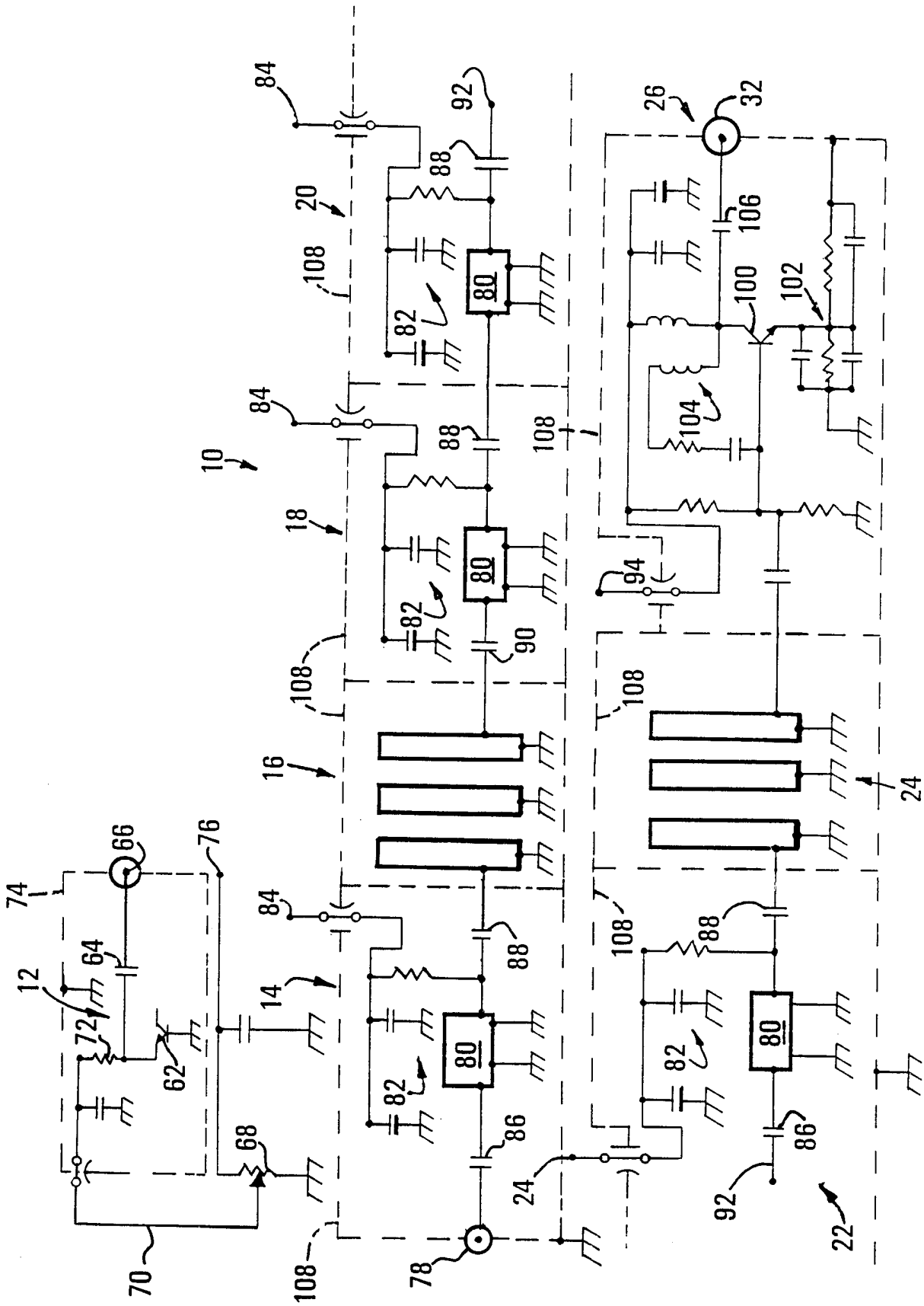

FIG 2

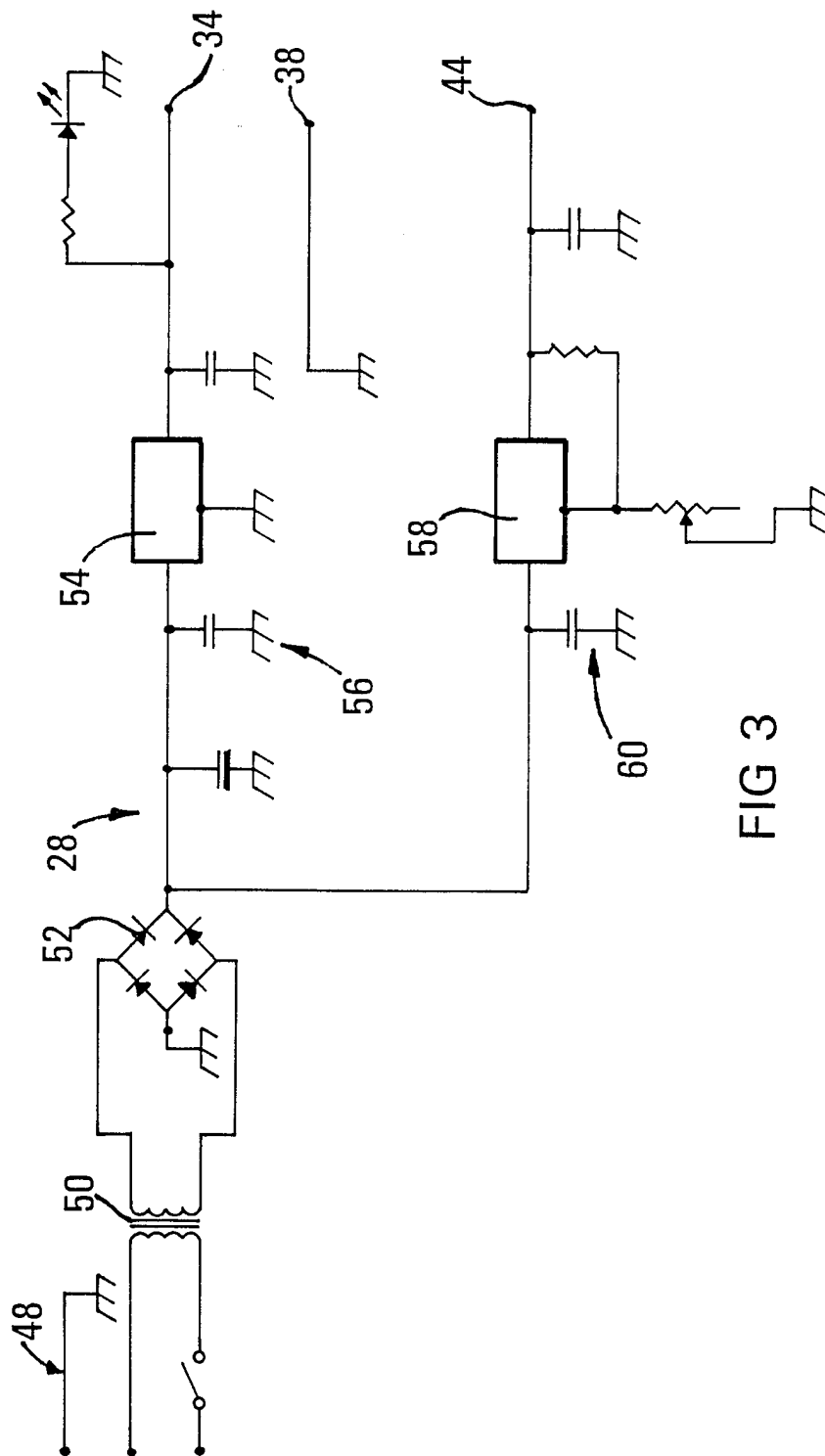

FIG 3

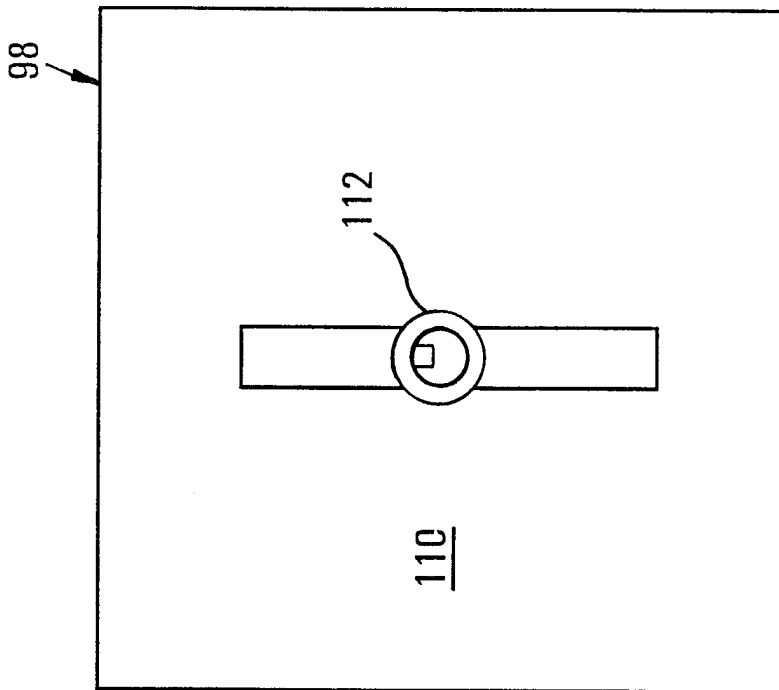

FIG 4

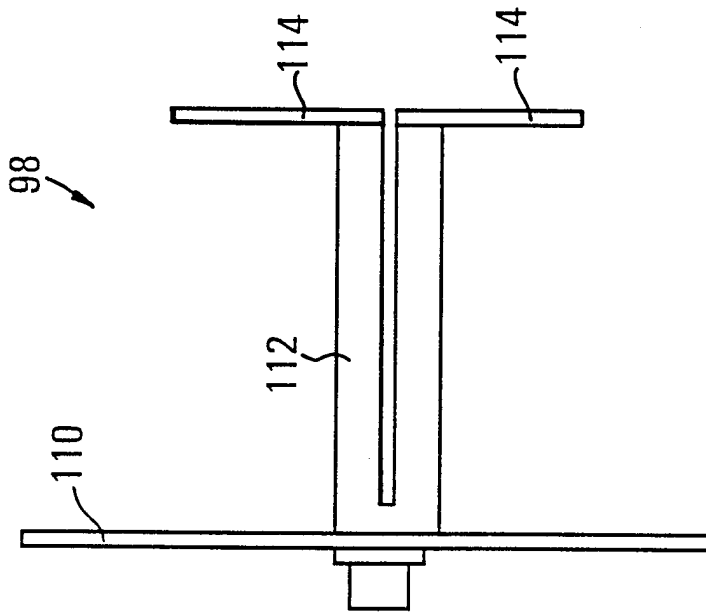

FIG 5

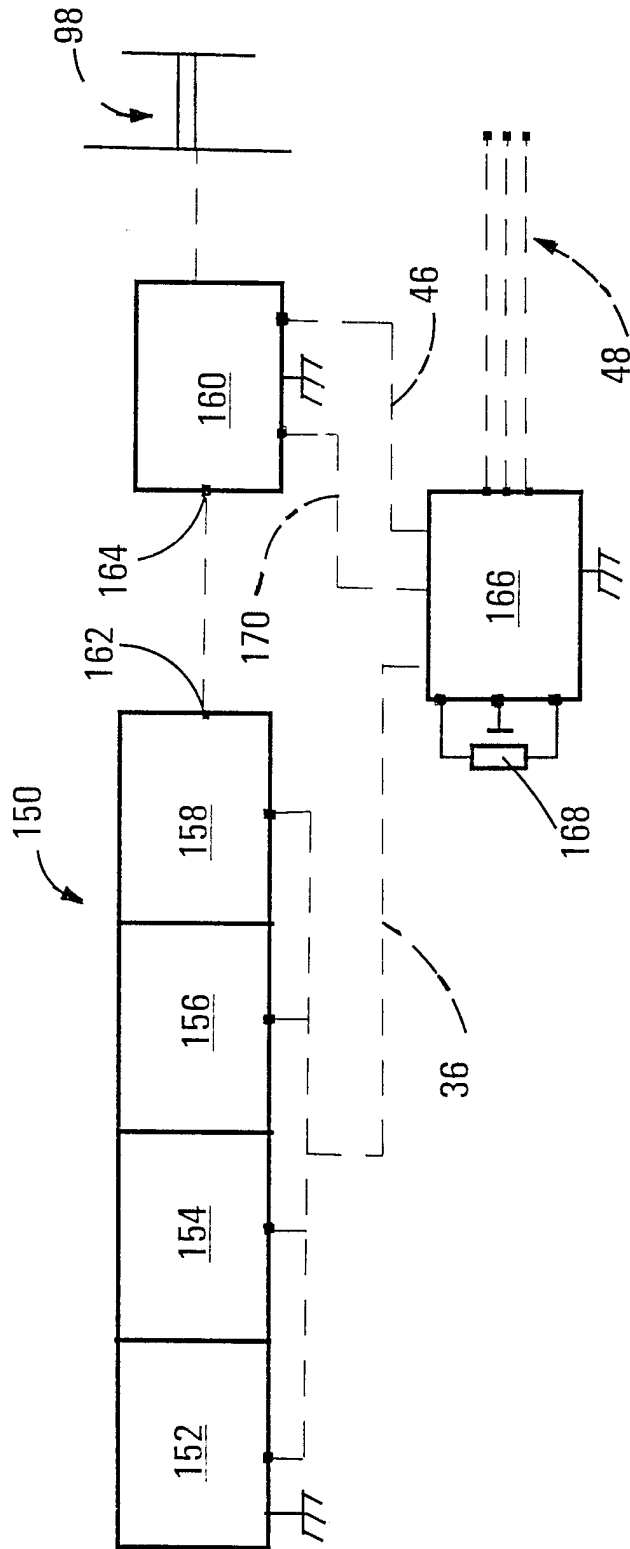

FIG 6

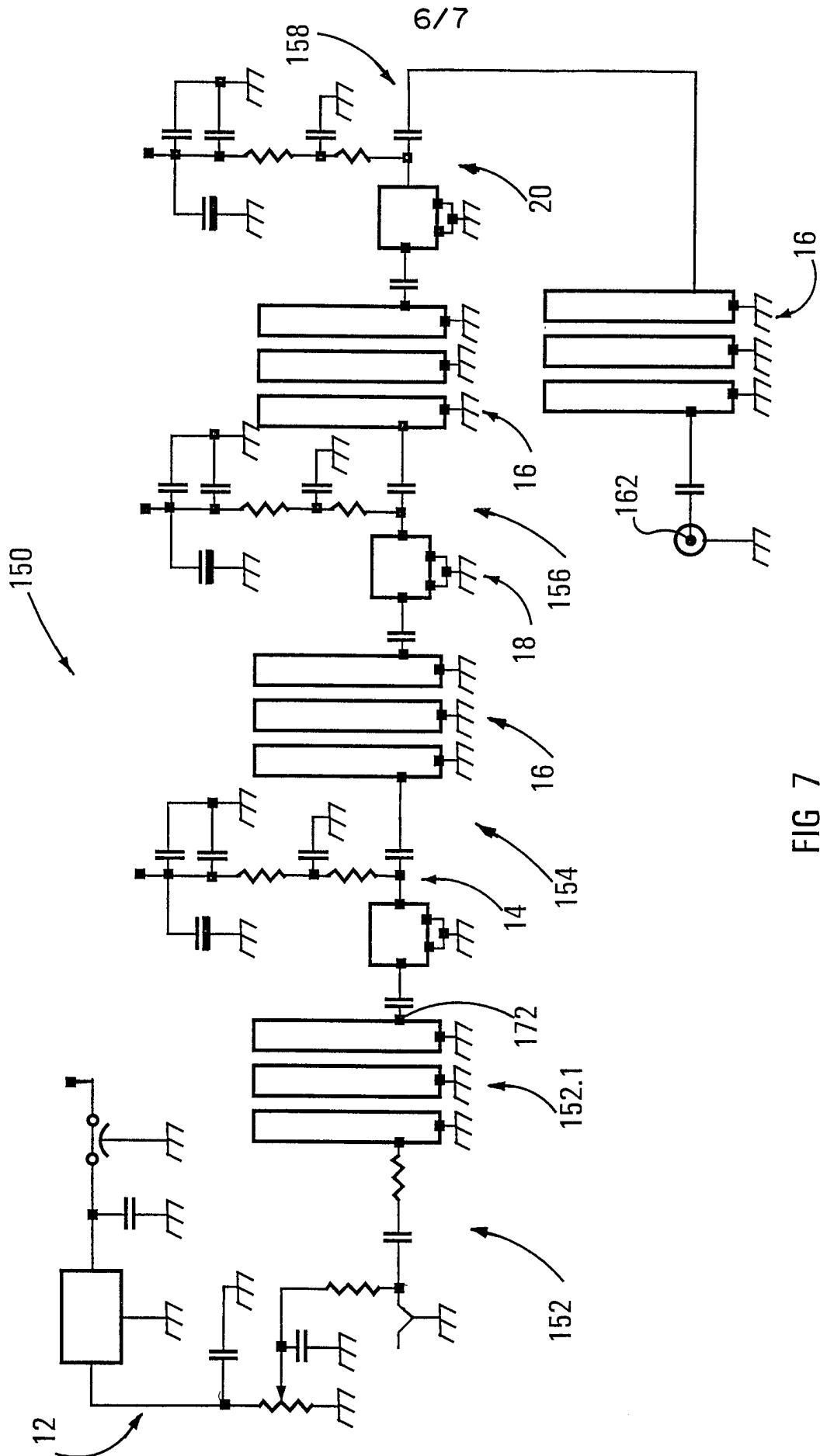

FIG 7

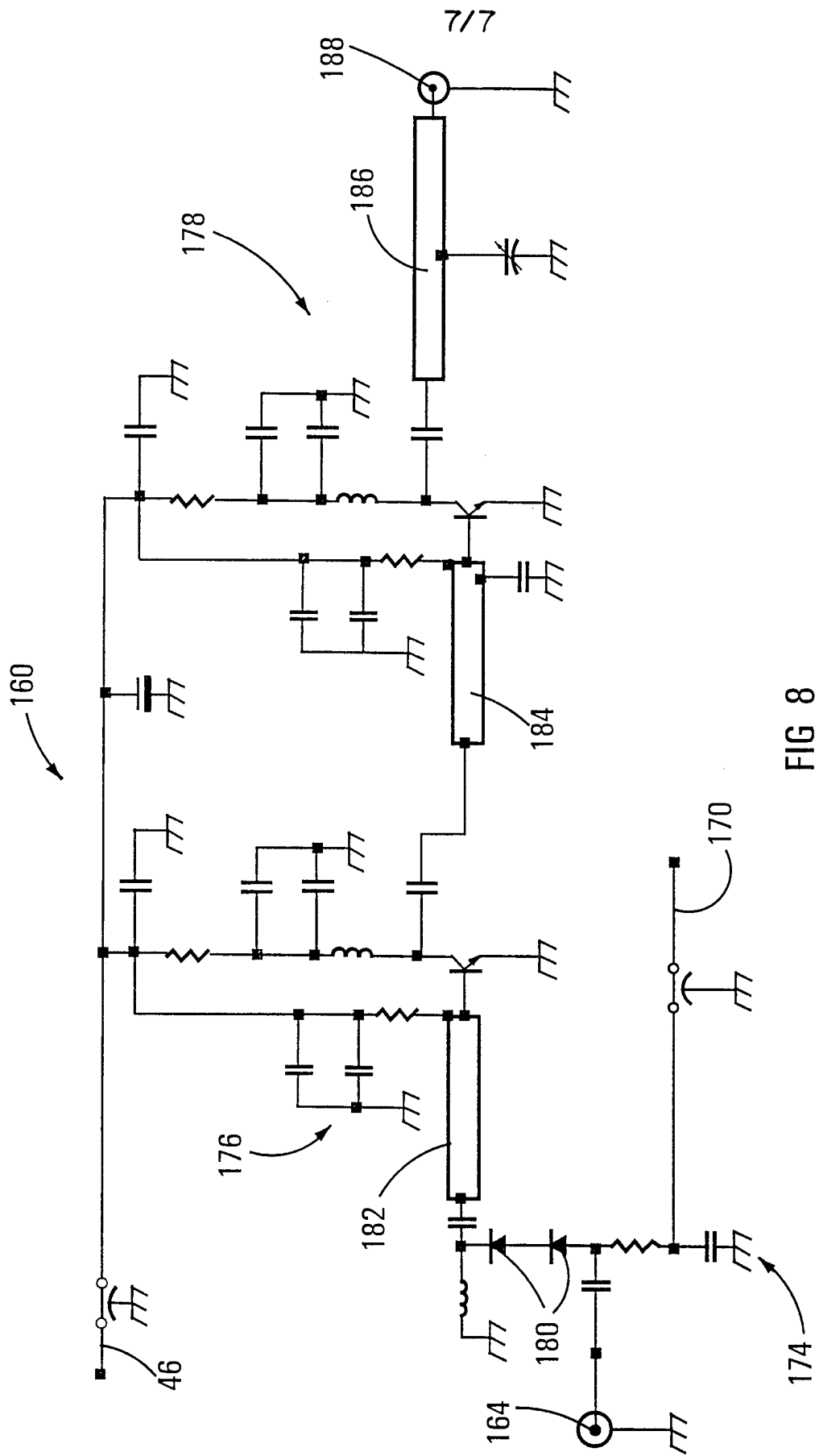

FIG 8

INTERNATIONAL SEARCH REPORT

International application No.
PCT/US97/14244

A. CLASSIFICATION OF SUBJECT MATTER

IPC(6) :H04K 3/00; H04B 1/06, 1/10; H04M 11/00; G01S 7/36
US CL :455/1, 26.1, 278.1, 296, 403, 456; 342/14

According to International Patent Classification (IPC) or to both national classification and IPC

B. FIELDS SEARCHED

Minimum documentation searched (classification system followed by classification symbols)

U.S. : 455/1, 26.1, 278.1, 296, 403, 456; 342/14

Documentation searched other than minimum documentation to the extent that such documents are included in the fields searched

Electronic data base consulted during the international search (name of data base and, where practicable, search terms used)

APS

C. DOCUMENTS CONSIDERED TO BE RELEVANT

Category*	Citation of document, with indication, where appropriate, of the relevant passages	Relevant to claim No.
Y	US 5,553,126 A (TANG) 3 September 1996, col. 3, lines 1-26.	1-14
Y	US 5,505,901 A (HARVEY ET AL) 9 April 1996, col. 2, lines 1-10, col. 10, lines 17-40.	1-14
Y	US 5,469,495 A (BEVERIDGE) 21 November 1995, col. 11, lines 21-31.	1-14
Y	US 5,295,180 A (VENDETTI ET AL) 15 March 1994, col. 9, lines 25-47.	1-14
Y	US 5,083,111 A (DRUCKER ET AL) 21 January 1992, col. 1, line 64 - col. 2, line 22, col. 2, line 65 - col. 3, line 31.	1-14
Y	US 4,217,550 A (BLASSEL ET AL) 12 August 1980, col. 1, lines 9-67.	1-14

Further documents are listed in the continuation of Box C.

See patent family annex.

* Special categories of cited documents:	"T" later document published after the international filing date or priority date and not in conflict with the application but cited to understand the principle or theory underlying the invention
"A" document defining the general state of the art which is not considered to be of particular relevance	"X" document of particular relevance; the claimed invention cannot be considered novel or cannot be considered to involve an inventive step when the document is taken alone
"B" earlier document published on or after the international filing date	"Y" document of particular relevance; the claimed invention cannot be considered to involve an inventive step when the document is combined with one or more other such documents, such combination being obvious to a person skilled in the art
"L" document which may throw doubts on priority claim(s) or which is cited to establish the publication date of another citation or other special reason (as specified)	"G" document member of the same patent family
"O" document referring to an oral disclosure, use, exhibition or other means	
"P" document published prior to the international filing date but later than the priority date claimed	

Date of the actual completion of the international search

04 NOVEMBER 1997

Date of mailing of the international search report

09 JAN 1998

Name and mailing address of the ISA/US
Commissioner of Patents and Trademarks
Box PCT
Washington, D.C. 20231

Facsimile No. (703) 305-3230

Authorized officer
Brian Johnson
BRIAN JOHNSON

Telephone No. (703) 308-305-3865