



INTERNATIONAL APPLICATION PUBLISHED UNDER THE PATENT COOPERATION TREATY (PCT)

(51) International Patent Classification ⁶ : H01P	A2	(11) International Publication Number: WO 99/36982 (43) International Publication Date: 22 July 1999 (22.07.99)
(21) International Application Number: PCT/US99/00859 (22) International Filing Date: 15 January 1999 (15.01.99) (30) Priority Data: 09/007,831 15 January 1998 (15.01.98) US (71) Applicant (for all designated States except US): K & L MICROWAVE, INC. [US/US]; 2250 Northwood Drive, Salisbury, MD 21801 (US). (72) Inventor; and (75) Inventor/Applicant (for US only): CAVEY, William, Weldon [-/US]; 5865 Peach Street, Salisbury, MD 21801 (US). (74) Agents: MEEKER, Frederic, M. et al.; Banner & Witcoff, Ltd., 11th floor, 1001 G Street, N.W., Washington, DC 20001-4597 (US).		(81) Designated States: AL, AM, AT, AU, AZ, BA, BB, BG, BR, BY, CA, CH, CN, CU, CZ, DE, DK, EE, ES, FI, GB, GD, GE, GH, GM, HR, HU, ID, IL, IN, IS, JP, KE, KG, KP, KR, KZ, LC, LK, LR, LS, LT, LU, LV, MD, MG, MK, MN, MW, MX, NO, NZ, PL, PT, RO, RU, SD, SE, SG, SI, SK, SL, TJ, TM, TR, TT, UA, UG, US, UZ, VN, YU, ZW, ARIPO patent (GH, GM, KE, LS, MW, SD, SZ, UG, ZW), Eurasian patent (AM, AZ, BY, KG, KZ, MD, RU, TJ, TM), European patent (AT, BE, CH, CY, DE, DK, ES, FI, FR, GB, GR, IE, IT, LU, MC, NL, PT, SE), OAPI patent (BF, BJ, CF, CG, CI, CM, GA, GN, GW, ML, MR, NE, SN, TD, TG). Published <i>Without international search report and to be republished upon receipt of that report.</i>
(54) Title: TUNABLE CERAMIC FILTERS		
(57) Abstract The present invention provides improved tunable filters which include improved tuning mechanisms and may include two opposed ceramic pucks.		

FOR THE PURPOSES OF INFORMATION ONLY

Codes used to identify States party to the PCT on the front pages of pamphlets publishing international applications under the PCT.

AL	Albania	ES	Spain	LS	Lesotho	SI	Slovenia
AM	Armenia	FI	Finland	LT	Lithuania	SK	Slovakia
AT	Austria	FR	France	LU	Luxembourg	SN	Senegal
AU	Australia	GA	Gabon	LV	Latvia	SZ	Swaziland
AZ	Azerbaijan	GB	United Kingdom	MC	Monaco	TD	Chad
BA	Bosnia and Herzegovina	GE	Georgia	MD	Republic of Moldova	TG	Togo
BB	Barbados	GH	Ghana	MG	Madagascar	TJ	Tajikistan
BE	Belgium	GN	Guinea	MK	The former Yugoslav Republic of Macedonia	TM	Turkmenistan
BF	Burkina Faso	GR	Greece	ML	Mali	TR	Turkey
BG	Bulgaria	HU	Hungary	MN	Mongolia	TT	Trinidad and Tobago
BJ	Benin	IE	Ireland	MR	Mauritania	UA	Ukraine
BR	Brazil	IL	Israel	MW	Malawi	UG	Uganda
BY	Belarus	IS	Iceland	MX	Mexico	US	United States of America
CA	Canada	IT	Italy	NE	Niger	UZ	Uzbekistan
CF	Central African Republic	JP	Japan	NL	Netherlands	VN	Viet Nam
CG	Congo	KE	Kenya	NO	Norway	YU	Yugoslavia
CH	Switzerland	KG	Kyrgyzstan	NZ	New Zealand	ZW	Zimbabwe
CI	Côte d'Ivoire	KP	Democratic People's Republic of Korea	PL	Poland		
CM	Cameroon	KR	Republic of Korea	PT	Portugal		
CN	China	KZ	Kazakstan	RO	Romania		
CU	Cuba	LC	Saint Lucia	RU	Russian Federation		
CZ	Czech Republic	LI	Liechtenstein	SD	Sudan		
DE	Germany	LK	Sri Lanka	SE	Sweden		
DK	Denmark	LR	Liberia	SG	Singapore		
EE	Estonia						

TUNABLE CERAMIC FILTERS**BACKGROUND OF THE INVENTION**

5 This invention relates to filters and, in particular, to systems and methods for use in implementing tunable ceramic filters in wireless communication systems.

Conventional constant percent bandpass filters are typically limited to around 2% and, at most, for some frequencies around 1%. However, these filters are inapplicable for certain applications where the percent of bandwidth is required to be less than 1%, such as less than 0.1% and more preferably less than around 0.08% as shown in Fig. 7. Although it may be possible to tune a conventional percent bandpass filter to have a narrow 3db bandwidth, the insertion loss becomes higher than an acceptable level such as 3db. For example, if a conventional constant percent bandpass filter is tuned to have less than 0.1% 3db bandwidth, the insertion loss may be as high as 6db or more. Accordingly, a new filter design is required for certain applications such as cellular base station testing applications and other suitable applications.

15 With reference to Figure 9, a second example of a conventional air wave guide tunable filter 300 is shown. The air wave guide tunable filter 300 may include a plurality of waveguide cavities 302 each having a capacitive tuning plunger 308 interconnected via a series of gears 301 and a knob 302 for turning the gears 301. The plunger 308 is a double helical metal plunger providing an RF short in the cavity 302 which makes the waveguide cavity appear smaller as the plunger is turned down into the cavity. Thus, it appears to the RF signal as if the cavity ceiling was made shorter. The cavities are connected at the outside via an input connector 304 and an output connector 305. Each of the cavities may also include a fine tuning adjustment screw 306.

20 The air wave guide tunable filters 300 are capable of having small percentage 3db bandwidth filters, but are not easily scalable to low frequencies. For example, a 3 cavity air wave guide filter for a one gigahertz signal may be required to have, for example, a plurality of nine inch cavities such as three nine inch cavities connected in series. Accordingly, these filters are not desirable in that they are large bulky and expensive to manufacture. The larger nine inch plungers are problematic in that they

30

must be machined to very high tolerances to provide the correct RF short and thus for the larger plunger sizes are problematic to machine at these close tolerances.

Referring to Figs. 10-11, another type of conventional tunable filter is termed an "air variable capacitor tunable filter" or air variable capacitance tuner 200. The air variable capacitance tuner 200 includes a single resonator 204 in a cavity 202 with a capacitive plate 201 that may be adjusted to have a variable distance from the resonator 204. A capacitor plate may fit into a slot 203 in the resonator 204 and be adjusted to either be closer to or further away from the resonator 204. The variable capacitance tuners 200 have poor insertion loss when tuned to a narrow band 3db bandwidth, and are therefore undesirable for some applications.

Waveguide cavity filters may be of a fixed configuration or of a tunable configuration. Fig. 8 illustrates a conventional dielectric loaded wave guide cavity which may be tuned to a higher frequency by moving the metal plate 330 lower in the cavity and closer to the ceramic puck 331. The problem with tuning the cavity of Fig. 8 is that as the metal disk is lowered closer and closer to the ceramic puck, to produce a higher resonant frequency, the Q of the cavity decreases substantially. Although the Q does not effect the 3db bandwidth which is still tunable, the reduction in the Q has a substantial impact on the insertion loss of the wave guide filter.

An alternative tunable filter is shown in Figure 12, where the ceramic puck 331 may be tuned by lowering a dielectric disk 332 closer to the puck. The lowering of the dielectric disk lowers the wave guide cavity in frequency. The problem with tuning the cavity of Fig. 12 is that as the dielectric disk 332 is lowered closer and closer to the ceramic puck 331 in order to produce a lower resonant frequency, the Q of the cavity decreases substantially. The reduction in the Q has a substantial impact on the insertion loss of the wave guide filter. Conventionally, the dielectric disks are used for fine tuning and not for severely altering the center frequency of the bandpass filter over a wide range.

A problem arises with conventional tunable waveguide cavity filters in that none of these filters provides a suitable configuration which allows severely altering the center frequency of a bandpass filter over a wide range while still maintaining an acceptable insertion loss.

SUMMARY OF THE INVENTION

Aspects of the present invention include achieving a narrow bandpass filter having a constant percent bandpass characteristics across a wide frequency range. The constant percent bandwidth characteristics are that the bandpass filter maintains a relatively constant percentage of the center frequency of the bandpass filter over a range which may extend up to 2 gigahertz or even up to 15 gigahertz or more. The upper range of the bandpass filter is, of course, limited by the type of ceramics utilized in the filter. One of the objects of the improved filter design was to maintain an insertion loss that is reasonable with respect to the bandpass characteristics such as 1.8db and up to around 3.0db. In some embodiments of the present invention, the filter may be configured as a constant bandwidth filter which maintains a constant bandwidth (e.g., 3.0db bandwidth) regardless of the frequency range of the filter. In other embodiments, the present invention may be utilized to construct a constant percent of center frequency bandpass filter (i.e., a constant percent bandpass filter) over a large frequency range.

In one aspect of the present invention, a tunable bandpass filter is made by including a plurality of waveguide cavities having two opposed ceramic resonators which are moveable mounted with respect to each other.

In a second aspect of the present invention, a plurality of tunable resonant waveguide cavities are formed, each having two opposed resonators which are moveable mounted with respect to each other.

In a third aspect of the present invention, a plurality of stepping motors are respectively coupled to a plurality of resonant cavities, each stepping motor for moving a first ceramic resonator relative to a second ceramic resonator in each of the resonant cavities.

Alternate aspects of the invention include one or more of the devices, elements, and/or steps described herein in any combination or subcombination. It should be clear that the claims may recite or be amended to recite any of these combinations or subcombinations as an invention without limitation to the examples in the specification.

30

BRIEF DESCRIPTION OF THE DRAWINGS

Figs. 1-3 show various arrangements of two opposing dielectric pucks;

Figs. 4-6 show different views of a first exemplary embodiment of aspects of the present invention;

5 Fig. 7 shows an example of a frequency response of the tunable filters discussed herein;

Fig. 8 shows various arrangements of an opposing dielectric and a puck;

Figs. 9-12 show various conventional arrangements of tunable filters.

DETAILED DESCRIPTION OF THE PREFERRED EMBODIMENTS

10 Referring to Fig. 1, it was found that the use of two pucks of approximately equal size in a waveguide cavity provides a substantially larger tuning range than where the upper puck is simply a dielectric disk of a substantially different size (e.g., as shown in Figure 12) or a metal disk (e.g., as shown in Figs. 8-11). Thus, it was found that for
15 tunable filters, the use of two opposed resonators (preferably of approximately equal size) provides significantly greater tuning range than conventional tunable filters. Again with reference to Fig. 1, as the two pucks are separated by a greater distance, the frequency to which the bandpass filter is tuned increases.

The design parameters as shown in Figures 2 are specified such that if a single
20 puck 361 were used, the single puck is specified such that it operates at a slightly lower frequency to the desired frequency of, for example, 1700 megahertz. The single puck may then be divided in half to provide the size of the two opposing pucks 371, 372. Thus, standard design calculations may be utilized to determine the approximate size
25 of the pucks in order to get the lower range of the desired frequency of the bandpass filter. Splitting the pucks into two pucks of approximate size makes the puck appear as if it were larger. Accordingly, it is often desirable to utilize two pucks which, when combined, may equal approximately 107% of the size of a single puck had only a single
30 puck been utilized. Using this approximation, it is possible to use standard software and/or calculations to determine the desired size of the two opposed pucks for the present invention.

In exemplary embodiments, two disk shaped ceramic pucks of approximately equal size are utilized and provide excellent results. However, alternate embodiments of the invention may use different configurations. For example, different embodiments may utilize two pucks with alternate configurations such as different shapes and/or sizes. For example, Figure 7 shows one exemplary embodiment where two pucks are moved relative to one another and yet one puck resides inside the other puck. This configuration also provides suitable results.

In the pucks for the present invention, the height to diameter ratio is non-conventional. The standard ratio is 0.35 to 0.45 (height divided by diameter). However, the pucks of the present invention were specially made and are approximately half the thickness of conventional pucks with the same diameter and violate the industry standards for height to diameter ratios.

Further, although a single tunable cavity may be utilized to achieve a large tuning range in accordance with one or more aspects of the present invention, it was found that the shape factor of the bandpass filter, i.e., the difference in the bandwidth between 3db and 40db attenuation is improved with additional sections. However, empirical test results indicated that the addition of additional sections introduces a complex problem of being able to tune all of the sections simultaneously in order to consistently maintain the tunability of the filter over a larger range. For example, where the tuning of each of the filters is done via a tuning belt and/or a gear arrangement, it is often difficult to maintain the fine tuning required for the performance specifications of the present filter over a wide frequency range. Even where a stepper motor is utilized, it was found that the use of only a single motor to tune all of the filters produced unacceptable results where all of the cavities were mechanically linked together.

However, this problem may be solved by using a new tuning mechanism. Referring to Fig. 4, it was found that a tuning mechanism may include an electromechanical device which moves the pucks relative to one another electronically based on a particular control algorithm produces excellent results. In the illustrated embodiment, the tuning puck may be controlled with an arrangement of a stepper

motor which rotates a shaft through the top of the wave guide cavity and thus moves the tuning puck up and down.

The stepper motor arrangement shown in Fig. 4 has each of the cavities being independently controllable by a separate stepper motor. Additionally, even better results may be achieved where the puck that is movable relative to the other puck does not turn. The turning causes additional variations in the tuning of the filter and thus is undesirable. Accordingly, it is superior to move the upper puck up and down without turning the upper puck.

Referring specifically to Fig. 4, a standoff such as a Lexan or other standoff 4 may be utilized to support for example a fixed location puck 3. Additionally, it may be desirable to have a separate puck 2 which is movable with respect to puck 3 in the vertical direction. The separate puck 2 is preferably movable in the vertical direction with the puck 3 in a non-rotational manner. For example, if the puck 2 rotates with respect to puck 3 as the filter is tuned, deformities and/or non-uniformities in the base of the pucks affect the particular dielectric loading of the resonant wave guide. Thus, it is desirable to move the puck 2 relative to the puck 3 in a non-rotational manner.

A second stand-off or shaft 5 may be utilized to support the second puck 2 and is preferably positioned within a sleeve 14 to prevent the stand-off 5 from being skewed to one direction or another. Additionally, a tuning nut or carrier block 9 may slide up and down on support 10 such that the tuning nut is prevented from moving from side to side and hence the standoff 5 is kept in perfect vertical alignment. Additionally, slop within the tuning nut 9 may be prevented by use of spring 11 and lead screw 8 which may have a precision thread. For example, it is preferable that the tuning nut 9 and the lead screw 8 are precision cut to have for example, 28 threads per inch or 32 threads per inch or even a higher thread count and may be precision manufactured on a lathe and custom fit together so that they have very close tolerance such as, for example, only a few ten thousandths of slop in between the screw and the tuning nut. Additionally, spring 11 helps to prevent slop of the tuning nut by keeping the tuning nut pushed against the lead screw such that the variation is minimized.

Additionally, an infrared sensor may be utilized to provide an index point or a common location upon which the stepper motor may be able to determine the exact

positioning of the ceramic disk 2 and to reposition the ceramic disk 2 in the exact location of which it was previously located.

5 The wave guide filter 1 may optionally be coupled to a plurality of digital stepper motors 13 such that each of the individual movable disks 2 are separately and/or jointly controllable by the stepper motor 13. Where a plurality of stepper motors are utilized to provide increased precision, it may be desirable to control each of the stepper motors separately. However, where a single stepper motor is utilized, a gear or other belt type arrangement, such as a timing belt, may be utilized to couple all of the ceramic disks 2 together so that they are tuned in and out simultaneously through the use of a single stepper motor. However, for some applications of the present invention, it difficult to obtain the high level of accuracy necessary for some types of filters using a single stepper motor. Accordingly, it may be desirable to use a plurality of stepper motors each controlling a separate lead screw 8 and each controlling separately tunable and movable ceramic pucks 2.

15 One exemplary embodiment uses a network analyzer 14 which may include a frequency sweep generator and a frequency analyzer (also not shown) to stimulate the wave guide cavity filter 1, to record the output of the wave guide cavity filter, and to feedback this information to CPU 16. The network analyzer 14 may optionally be controlled by CPU 16 and/or may have a separate control arrangement. In an exemplary embodiment, the control of the resonant wave guide cavity filter 1 may be accomplished by obtaining an index from sensor 12 by using A/D converter 15 and/or any other comparison circuitry into CPU 16. In most preferred embodiments, an A/D converter is utilized because it is possible to determine the point where the lead screw 8 is currently positioned by looking at the A/D converter and making a determination of the position by examining the current level of the output of the A/D.

20 In some embodiments, it may be desirable to place a window such that the A/D converter in the sensor should preferably be configured such that the A/D converter always receives a signal that is not at the maximum nor at the minimum such that a determination may be made that the sensor in the A/D converter is currently functional.

25 The A/D converter also provides a warning when the tuning screw or lead screw 8

30

approaches an extreme position at either end of the slide 10 such that the digital stepper motor 13 is not over torqued and burned up.

5 The CPU 16 may receive a signal of an index to determine the current position of the digital stepper motor and/or may move the lead screw 8 through the tuning nut 9 to establish an index position. Thereafter, movement of the digital stepper motor up and down may be recorded by CPU 16 such that the exact repeatable position of the ceramic disk 2 may be repeated. The CPU 16 may then establish reference ceramic wave guide filter performance data by utilizing a network analyzer 14 and recording the exact position of each stepper motor to achieve a particular bandpass filter at a plurality of locations along the particular tunable range that the filter is expected to be
10 operated.

Thereafter, steps in between the ranges selected and analyzed by CPU 16 may be determined by an interpolation algorithm located in CPU 16. Additionally, the steps measured and recorded by CPU 16 may be recorded in any suitable location such as EEPROM/Flash RAM 19 and/or stored in a PROM device and burned at the
15 factory. Additionally, a keypad 17 and/or a display device such as a LED display 18 may be coupled to the CPU 16 such that the user in the field may reprogram the ceramic wave guide device to provide a bandpass filter at any frequency location along the spectrum.

20 Additionally, the CPU 16 may also contain an interface such as an IEEE 488 interface and/or a serial, parallel, or custom interface, a RS 232, a RS 422, a BCD, and/or other suitable interface for controlling the filter characteristics such that the CPU 16 may reestablish a predefined set of filter characteristics upon command. In this way, the filter may be custom set and/or dynamically varied for a testing situation or other environment by CPU 16 in response to external equipment or in response to
25 an input at the keypad 17. The particular filter settings may be displayed on an LED 18 and/or a liquid crystal device which may also be enhanced to provide a graphic curve showing the current filter characteristics which may be provided initially by network analyzer 14.

30 The filter drive assembly 7 may include an outer housing 13 that provides additional rigidity and structure to ensure that the disk 2 is tuned precisely. Although

the filter drive assembly 7 is shown in a preferred embodiment, it may alternatively be configured in any suitable mechanism provided the second ceramic puck 2 is moved precisely away from the first ceramic puck 3. For example, and alternative embodiment may include a piezoelectric fine tuning mechanism which moves the puck to a small degree. If a piezoelectric or other fine tuning mechanism is utilized, the digital stepper motor may or may not be utilized. In some embodiments, it may be desirable to tune solely with piezoelectric element such that the electricity applied to the piezoelectric element provides the adjustment necessary to tune the filter over a narrow and/or broad range. In this manner, the entire circuitry for the filter drive assembly is completely solid state so that there are no other moving parts other than the piezoelectric element. Thus the reliability is substantially enhanced and the fine machining necessary to produce the part is not required.

Another filter drive assembly that may be suitable for the current application is the use of a linear drive motor, such as a linear drive motor controlled by a stepping motor which allows the second ceramic puck 2 to be moved up and down with extreme precision. The linear drive motor may be especially adapted for allowing a rough approximation to a particular location with either an optical sensor and/or a piezoelectric element utilized for providing the fine tuning once the ceramic puck is moved to a particular location. Where the digital stepper motor(s) are utilized in conjunction with a piezoelectric element, the digital stepper motor may be incremented at a much higher rate without the necessary incremental precision.

Each of the above elements, features, and methods may be utilized alone or in combination with the other elements to provide improved waveguide cavity filters. It will be apparent to one skilled in the art that the particular coupling between each of the resonant cavities may be any conventional coupling used in the industry. For example, the coupling may produce either a constant percent filter and/or a constant bandwidth filter over the entire tunable range as is well known in the art with current conventional aperture and other coupling techniques. Additionally, coupling techniques including either capacitive and/or inductive coupling may be utilized to couple up any of the cavities together in conventional manner.

While exemplary systems and methods embodying the present invention are shown by way of example, it will be understood, of course, that the invention is not limited to these embodiments. Modifications may be made by those skilled in the art, particularly in light of the foregoing teachings. For example, each of the elements of the aforementioned embodiments may be utilized alone or in combination with elements of the other embodiments. Furthermore, it will be understood that while some examples of implementations are discussed above regarding the receiving components, the same principals, configurations and methods may be applied to transmitting circuitry. Accordingly, the appended claims are intended to cover all such alternate embodiments of the inventions.

CLAIMS

- 1 1. A tunable dielectrically loaded waveguide cavity filter with an extended tuning
2 range comprising two opposed ceramic pucks.

- 1 2. The tunable dielectrically loaded waveguide cavity filter of claim 1 wherein
2 each of the two opposed ceramic pucks have a height to diameter ratio of
3 approximately half that of industry standard pucks.

- 1 3. The tunable dielectrically loaded waveguide cavity filter of claim 1 wherein one
2 of the two opposed ceramic pucks is disposed inside the other.

- 1 4. A tunable dielectrically loaded waveguide cavity filter having a plurality of
2 stepper motors.

- 1 5. The tunable dielectrically loaded waveguide cavity filter of claim 4 including
2 a plurality of pairs of opposed ceramic pucks, each pair having at least one puck
3 coupled to a respective one of the stepper motors.

- 1 6. A tunable dielectrically loaded waveguide cavity filter having a movable
2 ceramic puck which moves vertically within a waveguide cavity without turning the
3 ceramic puck.

- 1 7. A tunable dielectrically loaded waveguide cavity filter having a spring, a
2 movable ceramic puck, and a screw coupled to the movable ceramic puck for adjusting
3 a position of the movable ceramic puck, the spring applying a force against the screw
4 to reduce slop.

- 1 8. A tunable dielectrically loaded waveguide cavity filter including a movable
2 tuning mechanism, a CPU and a memory, the CPU controlling the tuning mechanism
3 to tune to different frequencies responsive to a plurality of predefined filter
4 characteristics stored in the memory.

- 1 9. A tunable dielectrically loaded waveguide cavity filter having a graphical
2 display graphing a bandpass frequency characteristic of the tunable filter.
- 1 10. A tunable dielectrically loaded waveguide cavity filter using an A/D converter
2 to determine a relative position of a tuning mechanism.
- 1 11. A tunable dielectrically loaded waveguide cavity filter having a first ceramic
2 puck disposed inside a second ceramic puck.
- 1 12. A tunable dielectrically loaded waveguide cavity filter having a waveguide
2 cavity upper plate, an outer casing, and a stepper motor secured to the waveguide
3 cavity upper plate at a first end, the stepper motor including a second end secured to
4 the outer casing, the outer casing being disposed about the stepper motor and secured
5 to the waveguide cavity upper plate, thus providing added rigidity to the stepper
6 motor.
- 1 13. A tunable dielectrically loaded waveguide cavity filter including a piezoelectric
2 element for controlling a tuning mechanism.
- 1 14. A tunable dielectrically loaded waveguide cavity filter including a liner motor
2 for controlling a tuning mechanism.

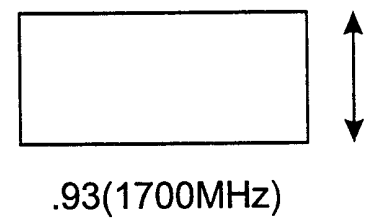
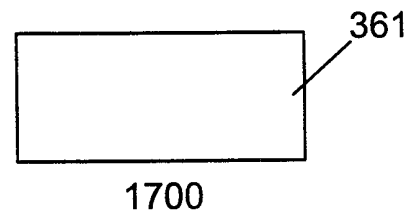
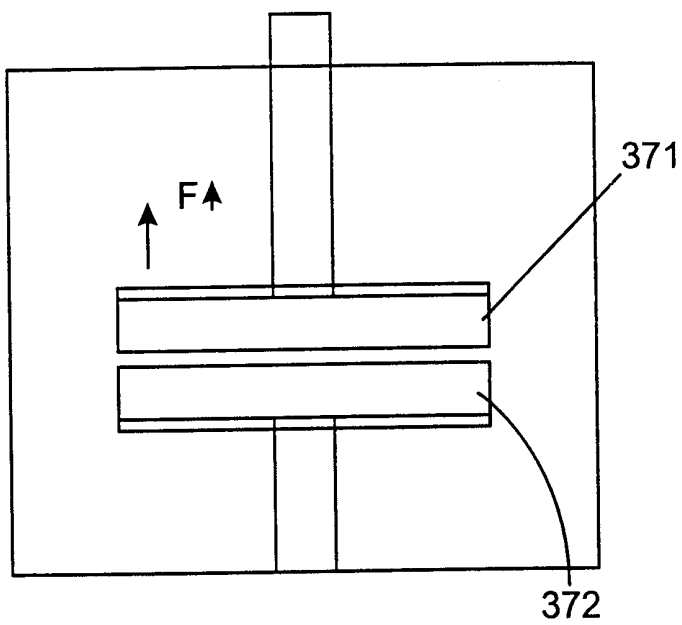

Fig. 2

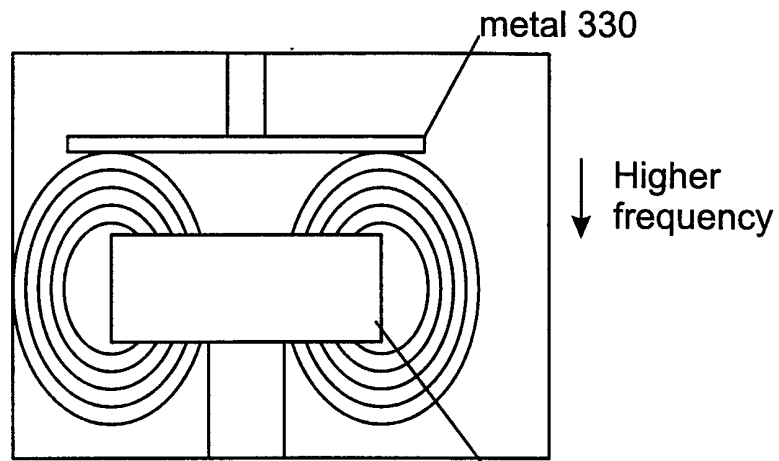

Fig. 8

331

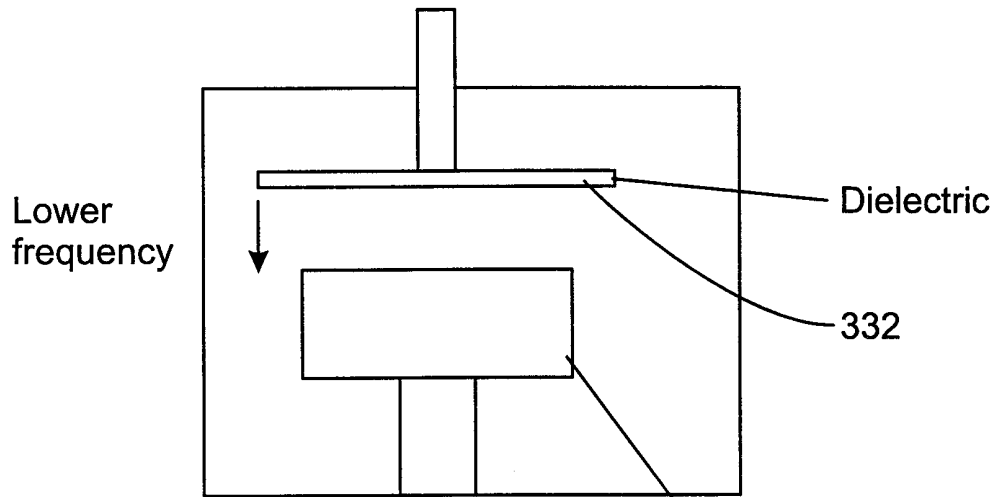

Fig. 12

331

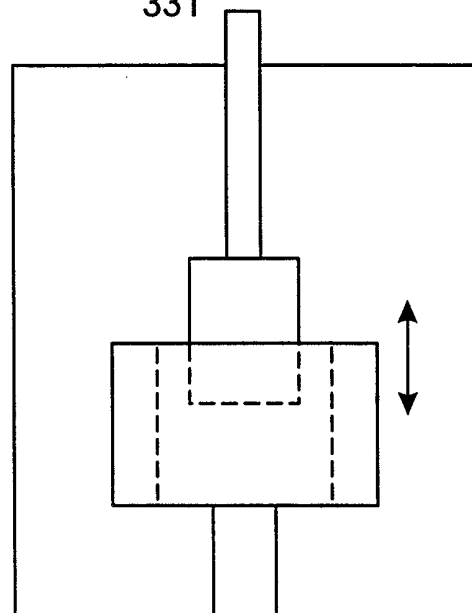

Fig. 3

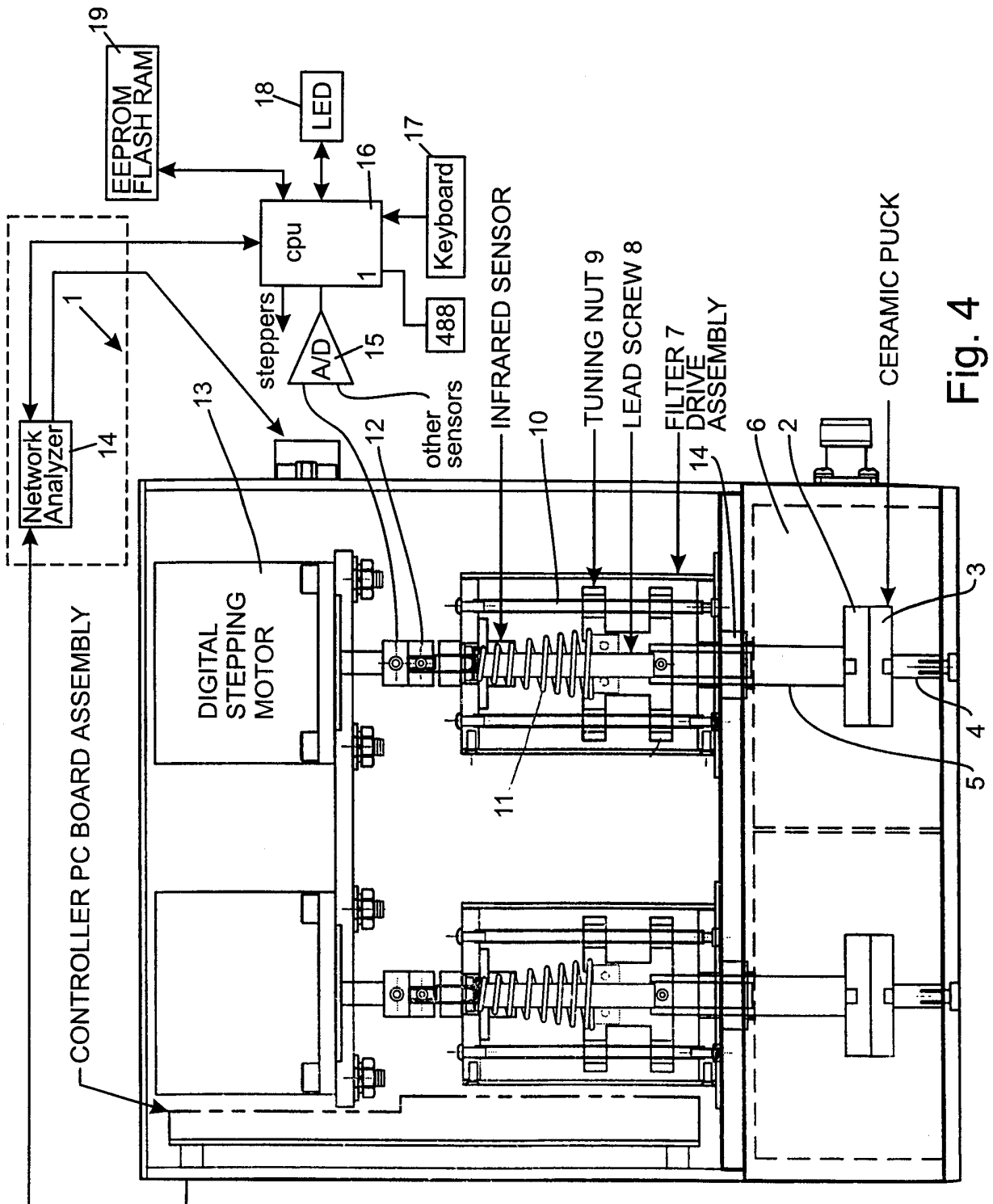

Fig. 4

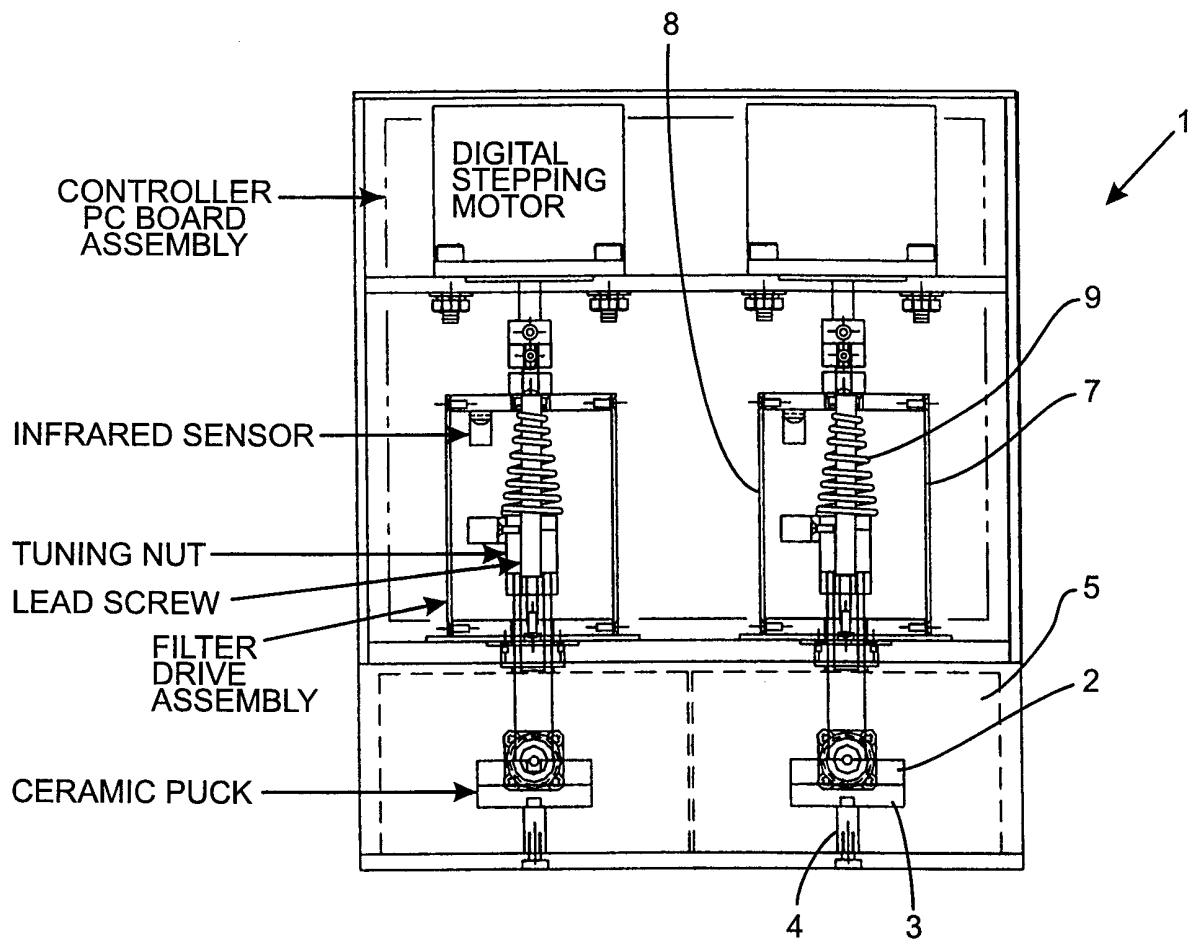

Fig. 5

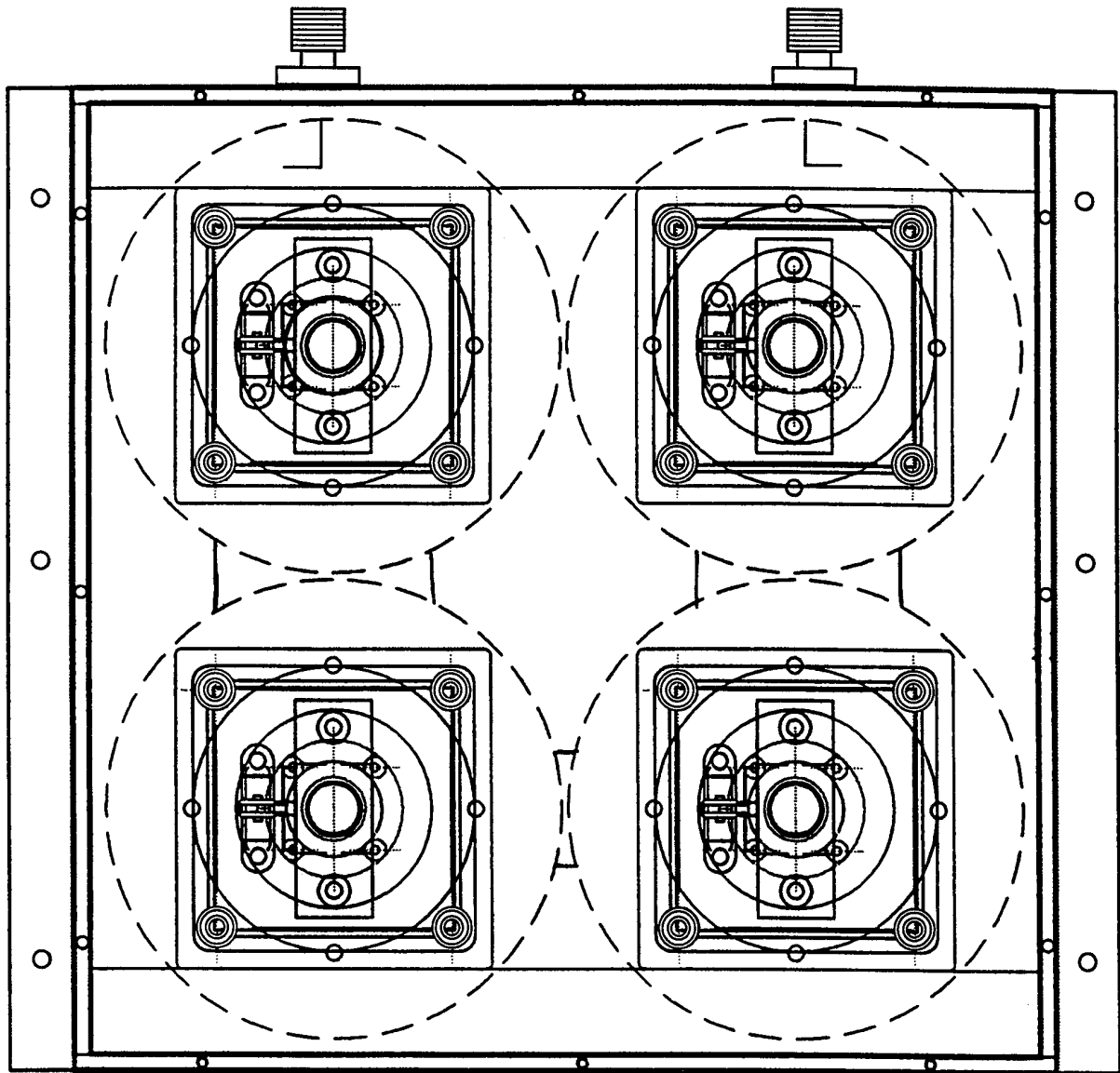

Fig. 6

Fig. 7

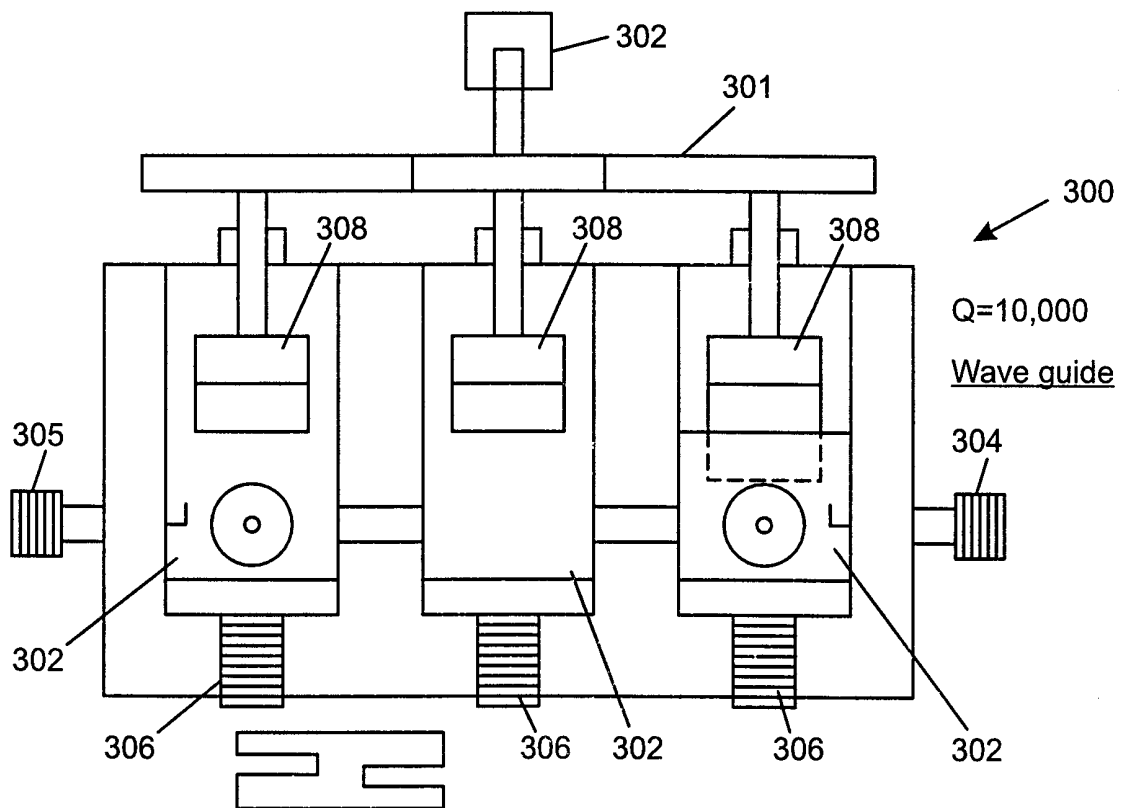
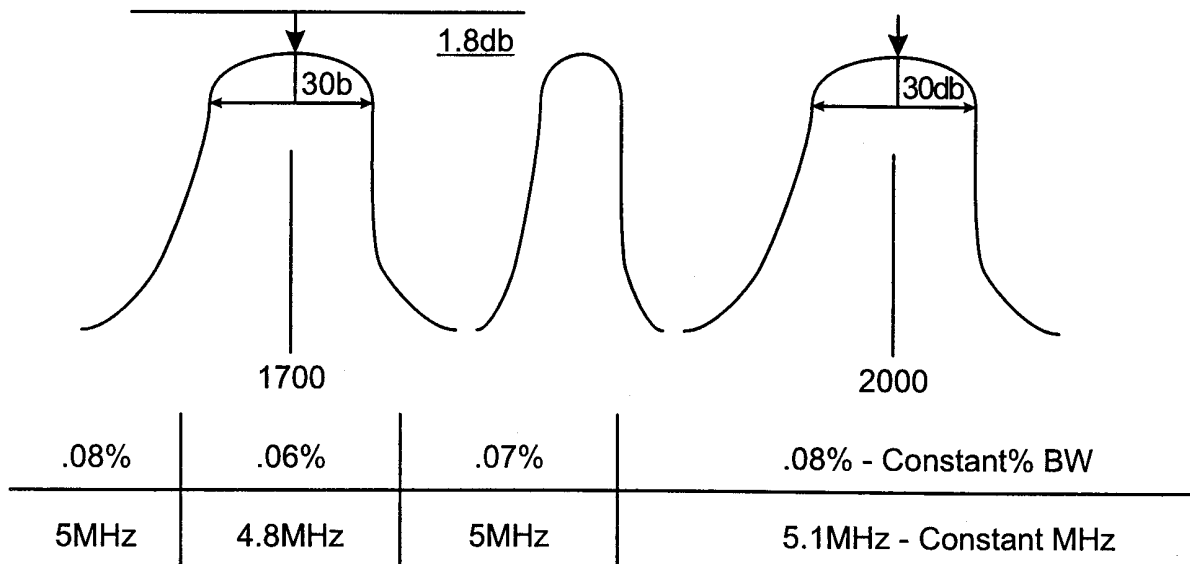

Fig. 9

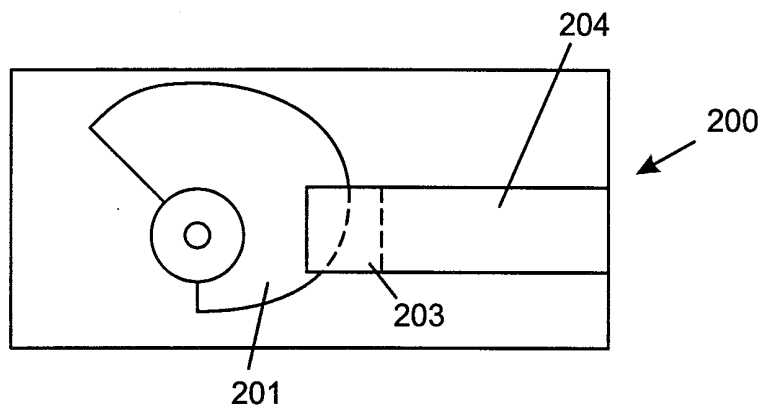

Fig. 10

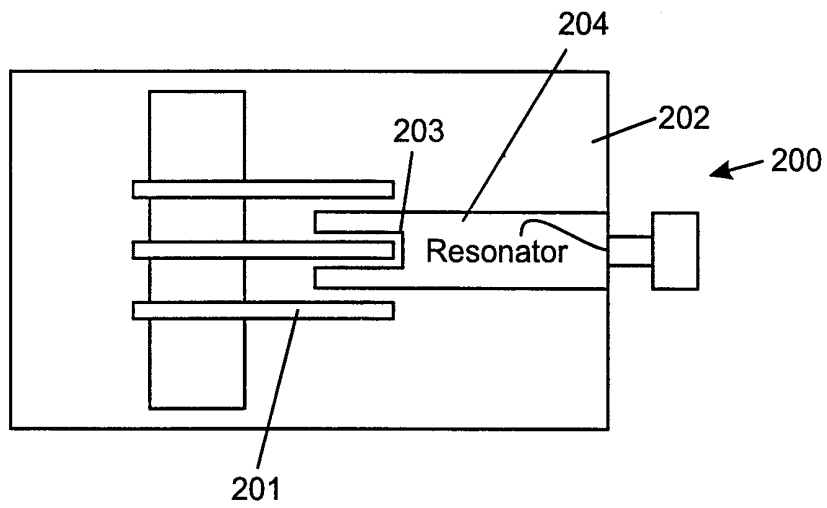

Fig. 11