

May 2, 1961

B. E. MARDEN
WRAPPING MACHINES

2,982,071

Filed March 4, 1959

2 Sheets-Sheet 1

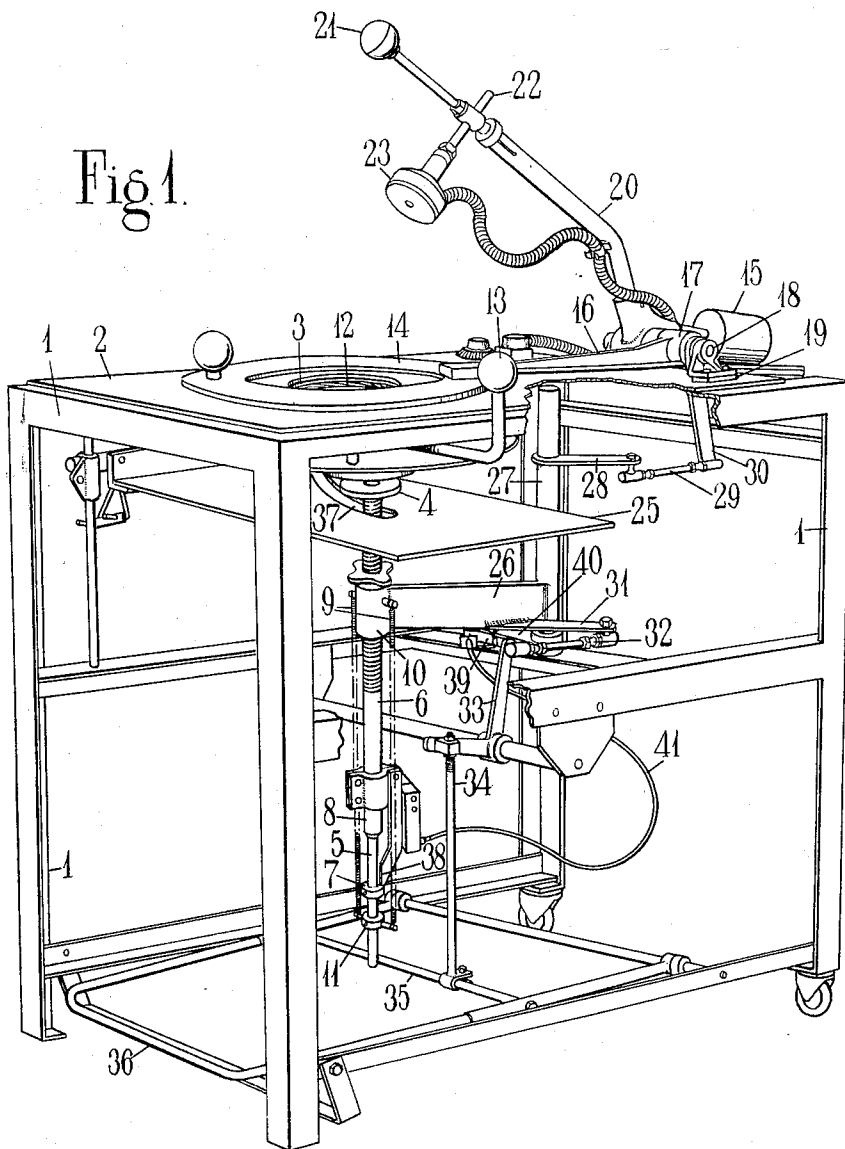

Inventor
B. E. Marden
D. G. Gosnell, Downing, Peckoll,
Attys.

May 2, 1961

B. E. MARDEN
WRAPPING MACHINES

2,982,071

Filed March 4, 1959

2 Sheets-Sheet 2

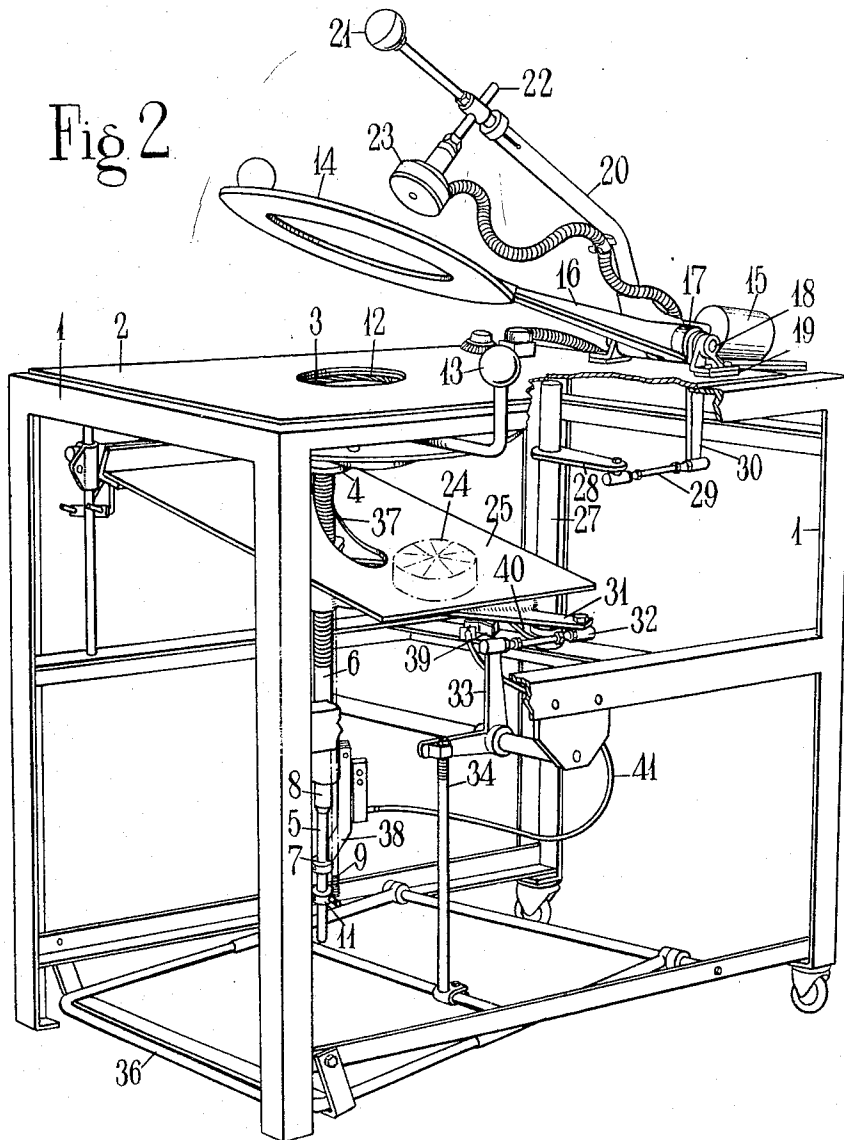

Inventor
B. E. Marden
By Glasgow Housing & Cold
Atty.

1

2,982,071

WRAPPING MACHINES

Bryan Ernest Marden, London, England, assignor to
Charles E. Douglas & Co. Limited, London, England

Filed Mar. 4, 1959, Ser. No. 797,230

Claims priority, application Great Britain Mar. 6, 1958

2 Claims. (Cl. 53—226)

This invention relates to wrapping machines and has for its main object to provide an improved machine for wrapping articles in cellulose film, paper or the like.

The invention is particularly applicable to a wrapping machine of the kind which comprises an apertured plate for receiving and supporting a sheet of wrapping material, retaining means for supporting a partially wrapped article after the article and the wrapping material have been passed through the apertured plate, and an aperture diaphragm comprising a plurality of overlapping leaves adapted to expand or contract the aperture under the action of manual control means after the manner of an iris, the diaphragm being disposed between said retaining means and said plate whereby the contraction of the aperture is adapted to draw the edges of the wrapping material together round the article while held in position by said retaining means.

The present invention has for its main object to provide improved means for removing an article from a wrapping machine after the wrapping operation has been completed and the invention accordingly consists in a wrapping machine of the kind referred to in the preceding paragraph wherein means are provided whereby the retaining or supporting means for the article may be moved away from its support position after the wrapping operation has been completed so as to allow the wrapped article to fall out or be removed from the lower part of the machine.

The invention will be more completely understood from the following detailed description which is given in conjunction with the accompanying drawings in which:

Figure 1 is a perspective view of a wrapping machine constructed in accordance with the invention and shown in the position which obtains after an article has been wrapped but while such article is still in position in the machine, and

Figure 2 is a perspective view of the wrapping machine shown in the position which obtains after the discharge mechanism has been operated for effecting the discharge of the wrapped article.

Referring now to these drawings, the wrapping machine is constructed in the form of a substantially box like container or frame 1, the upper part of which is formed of a rectangular plate 2 having a large circular hole in its centre, such hole registering with and fixedly locating a lower die-plate 3. The central aperture of this lower die-plate 3 may be of any desired shape and size to accommodate the article to be wrapped. Immediately below this aperture is arranged a substantially flat supporting member 4 of circular or other convenient shape mounted on the upper end of a vertical shaft 5 slidably arranged in a vertical tubular member 6, the supporting arrangements for which will be hereinafter described. The supporting member 4 is located in its uppermost position by an adjustable stop ring coming in contact with the lower end 8 of the aforesaid vertical tubular member 6 and this stop ring is fixed in such a position that the upper part of the supporting member 4 just enters the

2

central aperture of the lower die-plate 3, and the supporting member 4 is normally held in this position by a pair of helical springs 9 which are tensioned between a collar 10 fixed to the tubular member 6 and a collar 11 fixed to the vertical shaft 5. On a level immediately underneath the lower die-plate is an iris diaphragm 12 formed from a plurality of overlapping plates which are linked with a controlling handle 13 projected through the side of the frame 1 so that movement of the controlling handle 13 in one or other direction causes the opening in the centre of the diaphragm 12 to expand or contract, such central opening being so arranged as to register with the supporting member 4 and with the centre of the circular aperture in the rectangular plate 2.

Immediately above the aforesaid lower die-plate is a corresponding but opposite die-plate which in its turn is secured to the underside of an annular shaped carrier 14 which is pivotally mounted and is so balanced by a counterweight 15, that it can be retained in any convenient position.

Conveniently this annular carrier 14 is bolted to a supporting arm 16 which projects from a sleeve member 17 which is pivotally mounted on a cross-shaft 18 mounted in brackets 19 on the upper part of the frame 1, the counterweight 15 being carried on an inclined shaft bolted to the aforesaid sleeve member. Secured to the sleeve member 17 is an upstanding curved arm 20 terminating in a handle member 21, and having near its end a transversely arranged shaft 22 terminating in a circular pressure head 23 which is so positioned as to register with the openings in the die-plates when the curved arm 20 is swung downwards.

In operation the annular carrier 14 with the upper die-plate attached is raised and a sheet of cellulose or other suitable wrapping material is laid centrally over the surface of the lower fixed die-plate. The annular carrier 14 with the upper die-plate is then lowered into its downward position so that the sheet of wrapping material is held taut between the two die-plates. The article to be wrapped is now placed centrally on the sheet of wrapping material which lies exposed across the central aperture of the die-plates, the supporting member 4 being held in its uppermost position by the springs 9 so as to hold the article in position. The actuating handle 21 on the curved arm 20 is now pulled down so as to cause the pressure head 23 to descend downward on to the centre of the article and push the latter downwards on to the supporting member 4 and lower the latter to a pre-set stop position, in which the pivoted detent 38 engages with the adjustable stop 7, this movement drawing the sheet of wrapping material from all directions radially inwards from the periphery of the sheet of wrapping material and wrapping it round the periphery of the article.

The supporting member 4 is now held in this position while the handle 13 controlling the iris diaphragm 12 is actuated so as to contract the central opening until only a small annular space is left between the blades of the diaphragm and the pressure head 23, the contracting movement of the diaphragm 12 drawing the upstanding edges of the sheet of wrapping material together over the top of the article. The diaphragm 12 is then opened to a sufficient extent to enable a gummed or heat activated label to be affixed to the bunched ends of the sheet of wrapping material.

In order to facilitate the removal or discharge of a wrapped article from the machine, the shaft 5 carrying the supporting member 4 together with the sleeve 6 in which it is mounted is so arranged as to be movable in a horizontal plane so that if the wrapping operation is completed the supporting member 4 can be moved sideways away from the wrapping position so as to allow the wrapped article 24 to fall downwards on to a delivery

3

chute or platform 25 from which it can be removed from the machine. Conveniently the aforesaid sleeve 6 is held in position by a horizontal arm 26 which is welded to the collar 10, and which extends from a vertical shaft 27 which is connected by a linkage or lever system 28, 29 and 30 to the sleeve member 17 controlling the upper die-plate carrier 14 and also by a linkage system 31, 32, 33, 34 and 35 to a pedal 36 so that this shaft 27 may be rotated by the pedal or by the raising of the die-plate so as to swing the horizontal arm 26 round in a horizontal plane and so move the vertical shaft 5 and the supporting member 4 away from the support position, any suitable stop means being provided for engaging the side of the wrapped article 24 so as to cause the article to dislodge itself from the supporting member 4 when the latter moves away.

Conveniently the shaft 5 of the supporting member 4 together with the sleeve 6 projects through a slot 37 in the platform or chute 25 which is adapted to receive the article when it is dislodged from the support member 4, this slot being of arcuate shape in order to permit the swinging movement of the shaft to be effected. This platform or chute 25 is hinged or pivotally mounted, and is so arranged that it is normally disposed substantially horizontally as shown in Figure 1 but is adapted to tilt over into an inclined position on receiving a wrapped article as shown in Figure 2 so as to cause the article to be automatically discharged on to a suitably arranged conveyor belt or other collecting device.

When the pedal 36 is released, the mechanism automatically returns to normal under the weight of the carrier plate 14 which falls back on to the plate 2 and through the aforesaid linkages causes the vertical shaft 5 with the support member 4 to move back under the aperture in the rectangular plate 2, the detent 38 at the same time being knocked away from the stop 7 by a small lever 39 which is acted upon by an arm 40 carried on the vertical shaft 27, the lever 39 acting on the Bowden wire 41 so as to pull the detent 38 out of its locking position against the action of its return spring.

I claim:

1. Wrapping machine comprising an apertured plate for receiving and supporting a sheet of wrapping material, a support member disposed on the upper end of a substantially vertical shaft for supporting a partially wrapped article after the article and the wrapping material have been passed through the apertured plate, an apertured iris diaphragm, means for contracting said diaphragm so as to draw the edges of the wrapping material together round the article while held in position by said

4

retaining means, a delivery chute disposed below said retaining means and actuating means for effecting the lateral movement of said vertical shaft after the wrapping operation has been completed so as to cause the wrapped article to be discharged from said support member on to said delivery chute, said delivery chute comprising a platform which is pivotally mounted so as to be tiltable under the weight of a wrapped article, said vertical shaft extending through an arcuate shaped slot in said platform, a rotatable shaft operatively connected to said actuating means and a rotary arm connecting said rotatable shaft to said vertical shaft, whereby a lateral swinging movement of said vertical shaft is effected by the operation of said actuating means.

2. Wrapping machine comprising an apertured plate for receiving and supporting a sheet of wrapping material, a support member disposed on the upper end of a substantially vertical shaft for supporting a partially wrapped article after the article and the wrapping material have been passed through the apertured plate, an apertured iris diaphragm, means for contracting said diaphragm so as to draw the edges of the wrapping material together round the article while held in position by said retaining means, a delivery chute disposed below said retaining means and actuating means for effecting the lateral movement of said vertical shaft after the wrapping operation has been completed so as to cause the wrapped article to be discharged from said support member on to said delivery chute, said delivery chute comprising a platform which is pivotally mounted so as to be tiltable under the weight of a wrapped article, said vertical shaft extending through an arcuate shaped slot in said platform, a rotatable shaft operatively connected to said actuating means and a rotary arm connecting said rotatable shaft to said vertical shaft, whereby a lateral swinging movement of said vertical shaft is effected by the operation of said actuating means, and a pivotally mounted apertured die-plate for locating the wrapping material in position during the wrapping operation, said apertured die-plate being operatively associated with said rotatable shaft by a linkage mechanism whereby the movement of said actuating means effects the simultaneous movements of said vertical shaft and said apertured die-plate.

References Cited in the file of this patent

UNITED STATES PATENTS

815,675	Blanc	May 20, 1906
2,838,897	Ponten	June 17, 1958
2,851,835	Collins	Sept. 16, 1958