

Oct. 28, 1958

M. POLLMANN

2,858,046

MACHINES FOR MAKING FILTER TIP CIGARETTES

Filed March 23, 1955

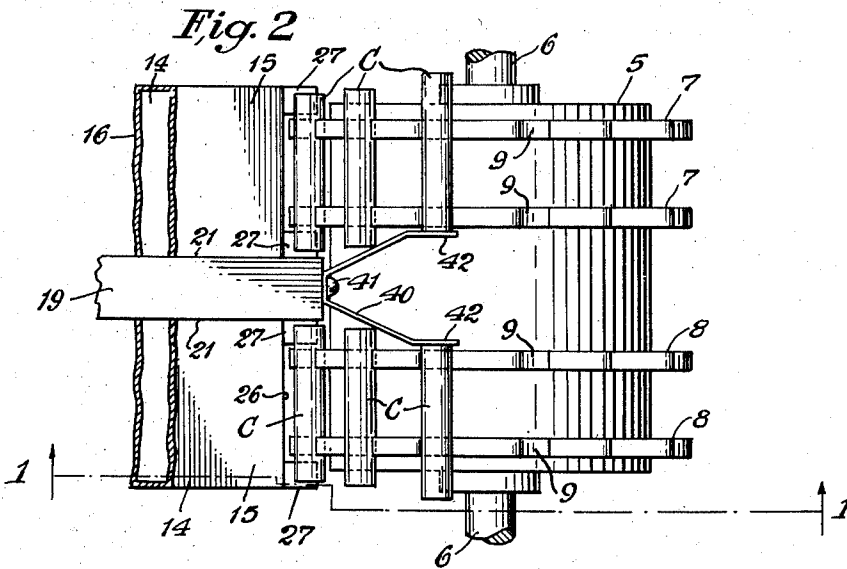
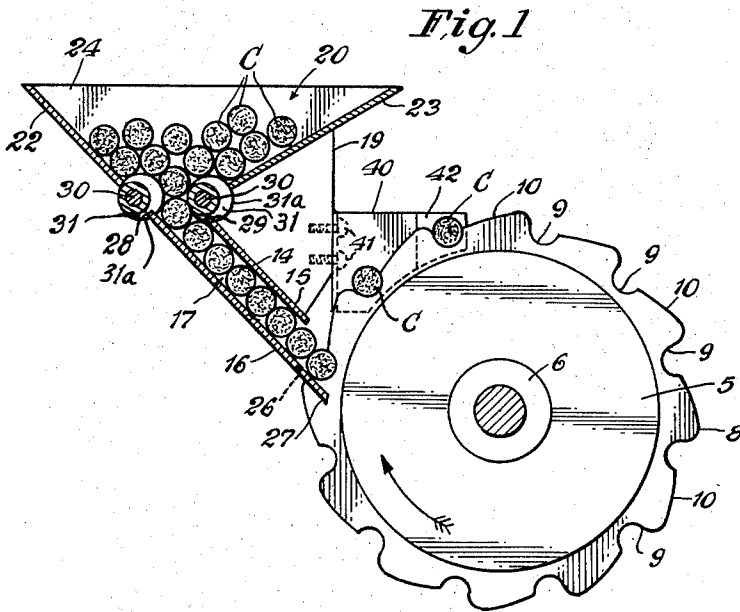

INVENTOR.

Max Pollmann
BY *Singer, Stein & Carlberg*

Attorneys

1

2,858,046

MACHINES FOR MAKING FILTER TIP CIGARETTES

Max Pollmann, Hamburg-Bergedorf, Germany, assignor to Kurt Korber & Co. K.-G., Hamburg-Bergedorf, Germany

Application March 23, 1955, Serial No. 496,277

Claims priority, application Germany March 31, 1954

2 Claims. (Cl. 221-93)

The present invention relates to cigarette making machines, and more particularly a machine for making filter tip cigarettes.

One object is to provide a machine in which a series of cigarettes are fed to circumferentially spaced notches in a pair of assembly drums and arranged in spaced axial alinement the proper distance such as to be positioned the correct linear distance apart equal to the length of a double mouthpiece or filter tip.

Another object is to provide a cigarette making machine in which the cigarette cartridges are fed to the periphery of a drum having spaced apart rings provided with circumferentially spaced apart notches having inclined areas adjacent the notches on one side thereof to facilitate guiding the cigarette cartridges tangentially to the drum periphery instead of radially.

Another object is to provide a cigarette making machine in which there is provided a pair of cigarette receiving drums having notches on the periphery thereof to receive cigarettes so that the magazine feed may be presented tangentially to the drum for the purpose of feeding cigarettes to the notches therein without the liability of the cigarettes becoming displaced while they are carried around a circular path on the drum to another station.

Another object is to provide a machine for assembling cigarette cartridges and filter mouthpieces or tips in which the cigarette cartridges are fed to a drum in axially and circumferentially spaced apart relation so that the ends of the cigarettes will be spaced a distance equal to the length of a double mouthpiece. The cigarettes in this manner are fed to a wrapper which secures the cigarettes and mouthpiece together so that they may be severed intermediate their ends to form two cigarettes, each of which is provided with a filter tip of exactly the same dimensions and uniformity.

Another object is to provide guide means adapted to engage the ends of the cigarette to properly space the same, and said guide means is located between adjacent sets of notched rims and is adapted to be supported on the feed magazine.

According to the invention a rotatable carrier is provided for accommodating spaced pairs of cigarettes, and these are fed to grooves or notches formed in spaced sets of annular rims carried by a rotary drum. The notches are inclined to the drum tangent such that the feed chutes may have the lower end portion arranged to receive said annular rim portions, whereby one wall of the feed chute or magazine will be notched to project on either side of the annular rims and thus insure proper feeding of the cigarettes. A gradual sliding movement of the cigarettes into the grooves of the magazine drum is thereby obtained efficiently such as to prevent the cigarettes from dropping out of position before they are finally deposited in the notches in the annular spaced members on the drum.

Another object is to provide a hopper or feed magazine having a pair of eccentric rollers adjacent the mouth

2

of the feed magazine between the hopper and chute such as to assist in alining the cigarettes with the chute and insure their proper entrance therein so that they will be discharged from the chute and presented to the rotating drum in proper relation to be received within the notches in the annular supporting rings on the drum.

Other objects and advantages of the invention will become apparent during the course of the following description of the accompanying drawing, wherein:

Figure 1 is a vertical cross sectional view taken on line 1-1 of Figure 2 and looking in the direction of the arrows to illustrate the manner in which the feed chute of the feed magazine is presented to the assembly roller or drum such as to deposit cigarettes in notches therein, and

Figure 2 is a fragmentary top elevational view of the assembly drum or roller showing the manner in which the cigarettes are deposited in notches formed in spaced relation in sets of annular members arranged on the drum. Means is illustrated for engaging the ends of axially alined pairs of cigarettes to properly space the same in the notches.

In the drawing, and more in detail, there is shown a drum 5 mounted on a shaft 6 which is adapted to be driven at a speed such as to properly feed cigarettes in spaced relation so that a filter may be deposited therebetween and finally wrapped and cut to form two cigarettes.

The drum 5 is adapted to rotate clockwise (Figure 1), and mounted on said drum is spaced sets of annular members 7-8. The annular members 7 and 8 are provided with a series of circumferentially spaced apart notches 9 which are connected together by outwardly inclined portions 10 which extend in a direction common to the direction of drum rotation. The annular members or rings 7-7 and 8-8 have their notches 9 equidistantly spaced such that the cigarettes deposited therein will be fed in timed relation to receive a mouthpiece, wrapper, and be cut intermediate their ends to finally form a pair of cigarettes.

Presented to the periphery of the drum 5 and to each set of annular members 7-7 and 8-8 is a pair of inclined chutes 14 formed by upper and lower walls 15 and 16 (Figure 2). The chute 14 is provided with side walls at the end portions 17 for connecting the top and bottom walls 15 and 16, and the inner edges of the walls 15-16 are spaced by a housing structure 19 forming part of a hopper assembly 20 (Figure 1). It will thus be seen, that the housing structure 19 with its vertical walls 21 forms the inner walls for the chutes 14, and in addition spaces the chutes a distance such that the cigarettes C will be fed to the notches 9 on the drum 5. The magazine hopper 20 for each chute 14 may be of any desired construction, but as shown in Figure 1, includes converging walls 22 and 23 connected by suitable end walls 24.

The lower portion of each lower wall 16 is notched as at 26 to provide spaced fingers 27 on the lower wall 16 of the chute 14 which are adapted to project on opposite sides of each pair of annular members 7-7 and 8-8. The projecting fingers 27 terminate a distance short of the drum periphery 5 and thus insure the proper deposition of the cigarettes C upon the notches 9. Since the drum 5 is rotating in a clockwise direction, it will be seen, that the inclined portion 10 provides a notch for the reception of the cigarettes which is wider at the bottom than at the top to give adequate support to the cigarette and insure that the same will not drop away from the notches during the continued rotation of the drum.

Mounted between the magazine hopper 20 and the chute 14 in suitable cut-away portions is a pair of rotary shafts 30 upon which is mounted eccentric rollers 31a

with circumferential recesses 31 arranged such that the large lobe of one eccentric roller will be presented inward into the throat of the chute 14, while the other enlarged lobe is directed outwardly thereof. The shafts 30 can be journaled in any suitable manner in the magazine 20 (not shown), and suitable gearing connecting the shafts 30 to a power source, such as an electric motor may be provided for driving the eccentric rollers 31 as above described. The upper ends of the chute walls 15, 16 are provided with upwardly extending fingers 29 and 28 respectively similar to the lower fingers 27 (see Fig. 2) which extends into the circumferential recesses 31 of the eccentric rollers 31a and assist in guiding the cigarettes into the chutes 14.

Mounted on the housing portion 19 of the hopper chute assembly is a V-shaped member 40 which is secured in place by means of one or more screws 41. The ends of the V-shaped member 40 terminate in parallel cigarette guides 42 which are presented to the inner ends of the cigarettes C as they approach the upper portion of the drum 5. As shown in Figure 1, the V-shaped member 40 projects tangentially to the drum 5 and extends between the inner annular members 7 and 8. Thus, the parallel portions 42 adjust the cigarettes C after they are fed to the notches 9 and assures their proper spaced apart relation axially for the reception therebetween of a mouthpiece filter of a length such that when the filter is secured to the ends of the cigarettes by wrapping, and finally cut intermediate the ends of the filter a pair of cigarettes will be formed which are identical in size, length and other dimensions.

It is to be understood, that the form of the invention herewith shown and described in the accompanying drawing is to be taken as a preferred embodiment of the same and various changes in the shape, size and arrangement of parts may be resorted to without departing from the spirit of the invention or the scope of the subjoined claims.

I claim:

1. In a cigarette making machine, a rotatable drum having on its circumference two pairs of axially spaced annular members each provided with a series of circumferentially spaced semi-circular notches of a size to receive therein a cigarette, the edge of each notch arranged forwardly in the direction of rotation of said drum being connected with a forwardly extending and outwardly inclined wall portion which is connected by a curved wall portion with a substantially radial wall portion extending outwardly from the rear edge of the preceding semi-circular notch, two magazine hoppers arranged side by side for feeding cigarettes to said drum, means for depositing two axially aligned cigarettes at a time into axially aligned notches of said annular members, said means including two inclined chutes leading from said magazine hoppers to said rotatable drum, each chute consisting of spaced parallel upper and lower walls between which a row of cigarettes moves downwardly during the rotation of said drum, each one of said lower walls being provided at its lower end with projecting fingers terminating short of the periphery of said drum to thereby guide the cigarettes into the notches of said annular members, said lower walls and said projecting fingers thereon forming an acute angle with said forwardly extending and outwardly inclined wall portions between said notches when the associated semi-circular notches are in a position to receive cigarettes from the lower ends of said chutes, a housing portion between said magazine hoppers to which the latter and the chutes are secured, and a substantially V-shaped member with parallel ends attached to said housing portion and extending forwardly of said chutes, and substantially tangentially of said drum and between said two pairs of annular members to axially

adjust the two axially aligned cigarettes deposited in said notches of said annular members to a spaced between the same which permits the insertion of a filter mouthpiece of double length between said axially spaced cigarettes.

2. In a cigarette making machine, a rotatable drum having on its circumference two pairs of axially spaced annular members each provided with a series of circumferentially spaced semi-circular notches of a size receive therein a cigarette, the edge of each notch arranged forwardly in the direction of rotation of said drum being connected with a forwardly extending and outwardly inclined wall portion which is connected by a curved wall portion with a substantially radial wall portion extending outwardly from the rear edge of the preceding semi-circular notch, two magazine hoppers arranged side by side for feeding cigarettes to said drum, means for depositing two axially aligned cigarettes at a time into axially aligned notches of said annular members, said means including two inclined chutes leading from said magazine hoppers to said rotatable drum, each chute consisting of spaced parallel upper and lower walls between which a row of cigarettes moves downwardly during the rotation of said drum, each one of said lower walls being provided at its lower end with projecting fingers terminating short of the periphery of said drum to thereby guide the cigarettes into the notches of said annular members, said lower walls and said projecting fingers thereon forming an acute angle with said forwardly extending and outwardly inclined wall portions between said notches when the associated semi-circular notches are in a position to receive cigarettes from the lower ends of said chutes, a pair of spaced parallel rotatable shafts mounted between the lower ends of the magazine hoppers and the upper ends of said two chutes, and eccentric rollers defining large eccentric lobes fixedly mounted on said shafts and arranged so that when the large eccentric lobes on one shaft extend into the outlet throat of the hoppers the large eccentric lobes on the other shaft face outwardly of said throat, said eccentric rollers being provided with circumferential recesses and the upper ends of said walls of said chutes being provided with upwardly extending fingers extending into said circumferential recesses to guide the cigarettes into said chutes; a housing portion between said magazine hoppers to which the latter and the chutes are secured, and a V-shaped member with parallel ends attached to said housing portion and extending forwardly of said chutes, and substantially tangentially of said drum and between said two pairs of annular members to axially adjust the two axially aligned cigarettes deposited in said notches of said annular members to a space between the same which permits the insertion of a filter mouthpiece of double length between said axially spaced cigarettes.

References Cited in the file of this patent

UNITED STATES PATENTS

1,099,705	Kolb	June 9, 1914
1,720,907	Koerner	July 16, 1929
2,150,596	Bingham	Mar. 14, 1939
2,166,486	Edwards	July 18, 1939
2,270,713	Belada	Jan. 20, 1942
2,550,616	Stephano	Apr. 24, 1951
2,602,453	Treble	July 8, 1952
2,649,761	Edwards	Aug. 25, 1953

FOREIGN PATENTS

373,770	Germany	Apr. 16, 1923
392,266	Great Britain	May 18, 1933
687,878	Great Britain	Feb. 25, 1953
1,098,950	France	Mar. 16, 1955