

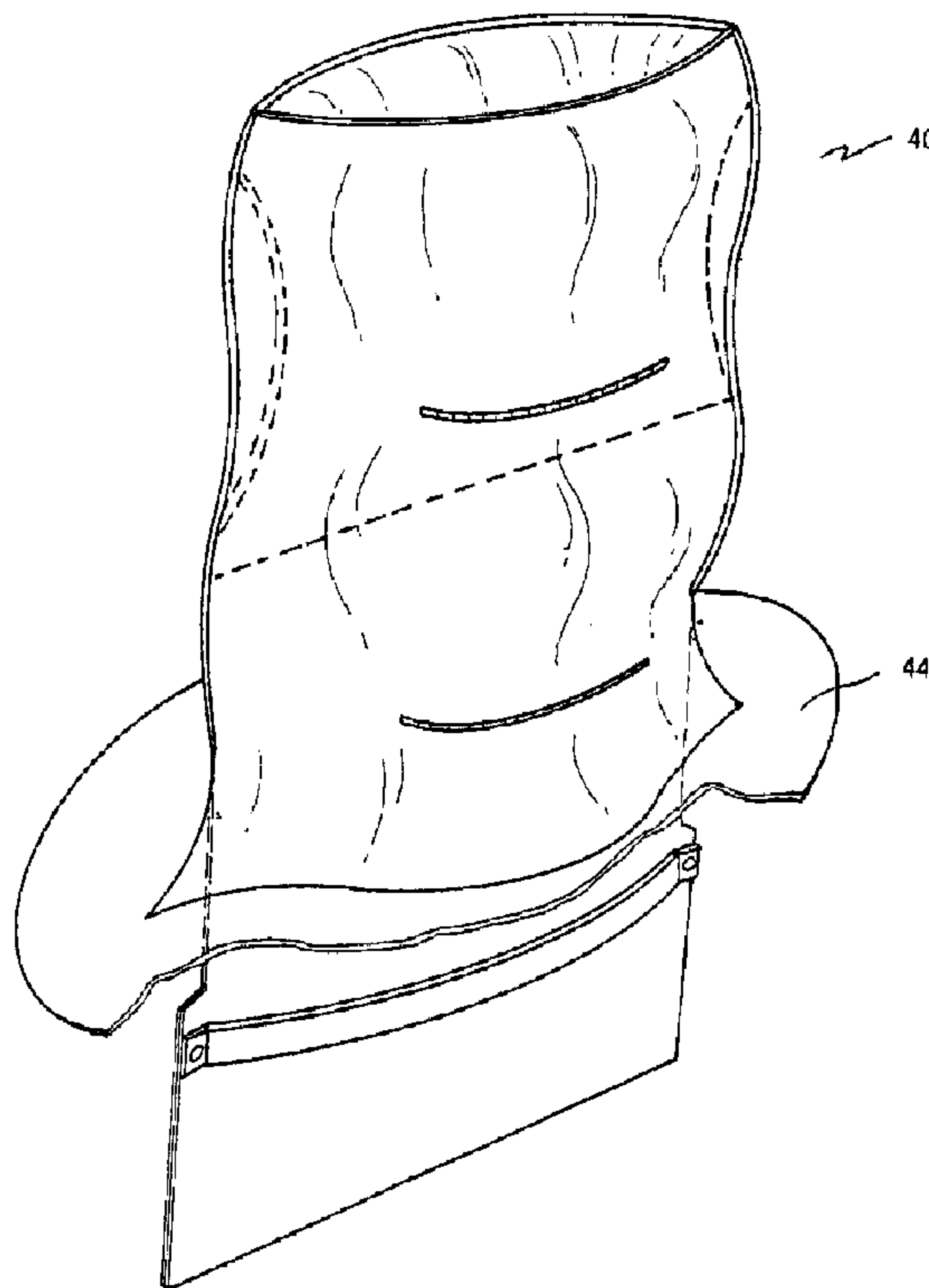

(86) Date de dépôt PCT/PCT Filing Date: 1995/02/20
 (87) Date publication PCT/PCT Publication Date: 1995/08/24
 (45) Date de délivrance/Issue Date: 2006/10/31
 (85) Entrée phase nationale/National Entry: 1996/08/09
 (86) N° demande PCT/PCT Application No.: IE 1995/000020
 (87) N° publication PCT/PCT Publication No.: 1995/022289
 (30) Priorités/Priorities: 1994/02/18 (IES940150);
 1994/08/05 (IES940613); 1994/12/07 (IES940960);
 1995/01/25 (IES950055)

(51) Cl.Int./Int.Cl. *A61M 39/02* (2006.01),
A61B 17/34 (2006.01), *A61B 19/00* (2006.01),
A61B 19/08 (2006.01), *A61B 17/28* (2006.01),
A61B 19/10 (2006.01)
 (72) Inventeur/Inventor:
 BONADIO, FRANK, IE
 (73) Propriétaire/Owner:
 GAYA LIMITED, IE
 (74) Agent: SIM & MCBURNEY

(54) Titre : APPAREIL A USAGE CHIRURGICAL
 (54) Title: ACCESS PORT DEVICE FOR USE IN SURGERY



(57) **Abrégé/Abstract:**

An access port device (40) for use in surgery is provided which comprises a sleeve (41, 42) having an exit opening located at a distal end thereof for insertion into an incision made in a patient's body, the exit opening allowing access to the patient's body cavity. The device (40) also includes exit opening sealing means for insertion into the incision. There is an entry opening located at a proximal end of the sleeve (41, 42) and entry sealing means for sealing the device in the region of the entry opening, so that when the patient's body cavity is inflated by gas, the exit sealing means and the entry sealing means prevent substantial leakage of gas from the patient's body cavity while the entry sealing means also provides access for a surgeon's hand or surgical instrument and sealing about the arm remaining outside the access port device. The invention also relates to surgical instruments for use with such an access port and to a surgical drape for use in surgery using the access port and instruments of the invention.



PCT

WORLD INTELLECTUAL PROPERTY ORGANIZATION
International Bureau

INTERNATIONAL APPLICATION PUBLISHED UNDER THE PATENT COOPERATION TREATY (PCT)

<p>(51) International Patent Classification ⁶ : A61B 17/34, 17/28, 19/00</p>	A3	<p>(11) International Publication Number: WO 95/22289 (43) International Publication Date: 24 August 1995 (24.08.95)</p>
<p>(21) International Application Number: PCT/IE95/00020 (22) International Filing Date: 20 February 1995 (20.02.95) (30) Priority Data: S940150 18 February 1994 (18.02.94) IE S940613 5 August 1994 (05.08.94) IE S940960 7 December 1994 (07.12.94) IE S950055 25 January 1995 (25.01.95) IE (71) Applicant (for all designated States except US): GAYA LIMITED [IE/IE]; 43 Fitzwilliam Place, Dublin 2 (IE). (72) Inventor; and (75) Inventor/Applicant (for US only): BONADIO, Frank [US/IE]; 2 Martello Terrace, Bray, County Wicklow (IE). (74) Agent: MACLACHLAN & DONALDSON; 47 Merrion Square, Dublin 2 (IE).</p>	<p>(81) Designated States: AM, AT, AU, BB, BG, BR, BY, CA, CH, CN, CZ, DE, DE (Utility model), DK, EE, ES, FI, GB, GE, HU, JP, KE, KG, KP, KR, KZ, LK, LR, LT, LU, LV, MD, MG, MN, MW, MX, NL, NO, NZ, PL, PT, RO, RU, SD, SE, SI, SK, TJ, TT, UA, UG, US, UZ, VN, European patent (AT, BE, CH, DE, DK, ES, FR, GB, GR, IE, IT, LU, MC, NL, PT, SE), OAPI patent (BF, BJ, CF, CG, CI, CM, GA, GN, ML, MR, NE, SN, TD, TG), ARIPO patent (KE, MW, SD, SZ, UG). Published <i>With international search report. Before the expiration of the time limit for amending the claims and to be republished in the event of the receipt of amendments.</i> (88) Date of publication of the international search report: 12 October 1995 (12.10.95)</p>	
<p>(54) Title: SURGICAL APPARATUS</p>		
<p>(57) Abstract</p> <p>An access port device (40) for use in surgery is provided which comprises a sleeve (41, 42) having an exit opening located at a distal end thereof for insertion into an incision made in a patient's body, the exit opening allowing access to the patient's body cavity. The device (40) also includes exit opening sealing means for insertion into the incision. There is an entry opening located at a proximal end of the sleeve (41, 42) and entry sealing means for sealing the device in the region of the entry opening, so that when the patient's body cavity is inflated by gas, the exit sealing means and the entry sealing means prevent substantial leakage of gas from the patient's body cavity while the entry sealing means also provides access for a surgeon's hand or surgical instrument and sealing about the arm remaining outside the access port device. The invention also relates to surgical instruments for use with such an access port and to a surgical drape for use in surgery using the access port and instruments of the invention.</p>		

- 1 -

ACCESS PORT DEVICE FOR USE IN SURGERY

5 The present invention relates to surgical apparatus, including an access port for minimally invasive surgery, surgical instruments for use with such a port and a surgical drape for use in surgery using the access port and instruments of the invention.

10 Minimally invasive surgery is surgery carried out by causing the minimum amount of trauma by incision in a patient's body. The apparatus of the present invention enables laproscopic hand/instrument assisted surgery to be performed and should substantially increase the number and variety of surgical procedures which can be performed without requiring open surgery. Minimally invasive surgery almost invariably involves deliberately
15 introducing gas into a patient's peritoneal cavity to cause pneumoperitoneum.

20 United States Patent Specification No. 5,176,649 discloses a flexible insertion device for inserting an endoscope or endoscopic operating instrument through the body wall, typically the chest or abdominal wall. The insertion device comprises a collapsible rigid plastic or
25 metal trocar inserter and a surrounding thin, plastic sheath with an adhesive collar. The insertion device enables the maintenance of an air-tight seal and permits the insertion of rigid, curved instruments without becoming dislodged from the body wall musculature. This
30 eliminates the necessity of multiple puncture and insertion procedures which otherwise would cause additional tissue injuries.

35 German Patent Publication No. DE 37 37 121 discloses a ring-shaped sealing collar made of an elastic material (or

- 1a -

material which is at least flexible) which is used for
sealing the thin-walled plastic hoses which are inserted
5 into the cavity organ during medical operations. The
specification discloses that when the interior of the collar
is filled with gaseous or liquid substances, it closes off
the cross-section to be sealed, narrows it or releases it
exactly as required. The sealing collar disclosed in the
10 specification, can be controlled hydraulically or
pneumatically and it is possible to partially or fully close
off the cross-section of the connection between the cavity
organ and the external environment, or also to release it
fully, according to requirements thus making it feasible to
15 use delicate instruments without any difficulty, especially
in combination with a conventional sealing system.

A sleeve for use in minimally invasive surgery forms the
subject matter of PCT Patent Application No. WO 95/07056.
20 The purpose of this prior art sleeve is to create a
controlled pressurized environment within the sleeve while
allowing a surgeon's arm to pass through the sleeve. For
surgery, gas is pumped into the patient's body cavity where
the surgery is to be performed and the purpose of the sleeve
25 is to prevent gas escaping from the patient's body cavity
while allowing the surgeon to operate using minimally
invasive surgery techniques. The patent application proposes
a sleeve having a flange at its distal end provided with
adhesive for adhering the device to the patient's body or
30 alternatively having a mounting ring at its distal end
surrounding the incision in a patient's body.

- 2 -

However, the prior art device suffers from the disadvantage, inter alia, that in use, the sleeve protrudes upwardly from the patient and may interfere with the activities of the surgery team.

5

The prior art device also suffers from the disadvantage that the sleeve includes a sealing means to seal the sleeve against the surgeon's upper forearm, which sealing means the surgeon has to effect himself by clamping the device to his arm. The clamp must be quite tight to avoid gas leak around the area of the seal.

10

A further problem associated with the use of sleeves of the kind described in PCT Patent Application No. WO 95/07056, is that a phenomenon known as "tenting" may occur. "Tenting" means that when the sleeve is adhered to the patient's skin or to sterilised wrapping material (also known and referred herein as "surgical drape" or "incise drape") which may in turn be adhered to the patient, the sleeve may have a tendency to pull away from the patient and "lift" the skin upwardly from the patient's abdomen which is inflated using gas for surgery. The sterilised wrapping material referred to above is also known as "surgical drape" or "incise drape". These latter terms will be used in the following description.

15

20

25

When surgery is being performed, the surgeon generally relies on a trocar and trocar sleeve to give access to the abdominal cavity while maintaining pneumoperitoneum. The trocar must be sharp to cut through and separate the muscle and fascia surrounding the abdominal cavity. The trocar sleeve allows entry and exit of instruments therethrough while sealing the pneumoperitoneum. A valve is included at the entry of the trocar sleeve which opens

30

2183064

- 3 -

to allow a surgical instrument such as a dissecting
scissors, a stapling instrument, forceps and such like to
pass through the valve and be moved through the trocar
sleeve into the abdominal cavity where the instruments are
5 manipulated by the surgeon. The valve closes when the
instrument is withdrawn.

Clearly, the dimensions of the surgical instruments must
be sized so that those instruments can fit through the
10 trocar sleeve.

Known devices suffer from the disadvantage that when the
surgeon wishes to use a different instrument which is
larger than the internal diameter of the trocar, he must
15 make an incision in the patient to gain access to the
tissue or organ or remove the tissue or portion of say the
bowel through the incision to work on it. Such an
incision will lose the pneumoperitoneum.

20 A surgical incise drape is a thin film polymeric material
usually made from polyethylene. It is transparent with a
mild adhesive on one side and a smooth non-adhesive
opposing side. The adhesive side is placed onto the
patient, over the entire abdomen or thorax, with careful
25 attention not to create any air pockets that could
propagate failure of the device to adhere. These drapes
are intended to isolate transmission of micro-organisms on
the surface of the patient's skin during surgery into the
incision wound. The surgeon is able to make an incision
30 through the drape without disrupting the adhesion of the
drape to the skin even in the area immediately adjacent to
incision.

The adhesive properties of the incise drape are well known
35 to have a low peel strength (if one was to peel from the

5 edge of the device), and very high pull strength (if one could find attachment within the periphery of the drape. This action is largely due to the elastic properties of the drape and the large surface area that it covers over the patients skin.

10 Regularly, it is required to anchor a component to the incise drape. In the prior art this anchoring is achieved by double sided strong adhesive tape connected to a polymer flange.

The present invention seeks to alleviate the disadvantages associated with prior art surgical apparatus.

15 In a first aspect, the present invention accordingly provides an access port device for use in surgery comprising a sleeve having an entry opening located at a proximal end of the sleeve and having an exit opening located at a distal end thereof for insertion into an
20 incision made in a patient' body, the exit opening allowing access to the patient's body cavity, characterised in that the device includes exit opening sealing means provided by the sleeve being collapsible by gas pressure within the abdominal cavity of the patient at
25 or adjacent the distal edges of the sleeve, whereby when the patient's body cavity is inflated by gas, the exit sealing means prevents substantial leakage of gas from the patient's body cavity while providing access for a surgeon's hand or surgical instrument.

30 Entry sealing means are provided for sealing the device in the region of the entry opening, whereby when the patient's body cavity is inflated by gas, the entry sealing means assists in preventing substantial leakage of
35 gas from the patient's body cavity while providing access for a surgeon's hand and sealing about the arm remaining outside the access port device.

2183064

- 5 -

The entry sealing means may comprise an inflatable chamber provided on the proximal end of the sleeve. The inflation chamber may be inflated using a separate valve from that used to inflate the patient's body cavity.

5 When the access port is in use, fluid communication is possible between the inflated chamber and the patient's body cavity so as to equalise the pressure in the inflated chamber and in the body cavity.

10 The sleeve may be provided with a flange having adhesive thereon for affixing the access port externally to the patient. The flange may be located between the proximal and distal ends of the sleeve so that in use, when the flange is adhered to the patient's body, the distal end of
15 the sleeve is inserted through the incision and is inside the patient's body cavity and the access port projects a short distance above the patient's body.

20 When the distal end of the sleeve is inserted through the incision, the patient's muscle tissue around the incision may act as a sealing means for assisting in sealing the intermediate portion of the sleeve between the distal end and the proximal end.

25 The entry sealing means may comprise an inflatable chamber arranged in surrounding relation to the sleeve and capable of exerting a pressure on the sleeve causing at least a portion of it to collapse thereby sealing the entry opening.

30 The inflatable chamber may not be in fluid communication with the sleeve, so that in use, the chamber is not in fluid communication with the patient's body cavity and thus the pressure inside the inflatable chamber may be
35 different from the pressure inside the patient's body

- 6 -

cavity.

Alternatively, the inflatable chamber may be in fluid communication with the sleeve.

5

The inflatable chamber is of generally "hour-glass" profile defining an upper chamber and a lower chamber, the lower chamber being insertable into the incision made in the patient's body cavity.

10

The sleeve and inflatable chamber may be co-axial and include sheets of a gas permeable flexible material bonded at their common proximal end and side edges, with the sleeve being within the inflatable chamber in the proximal region. The chamber may be defined between an outer sleeve located about the inner sleeve in the proximal region of the device and located within the inner sleeve and extending from the proximal end toward the distal end is a flap valve formed between two further sheets of flexible material.

20

The distal edges of the flap valve may be of a feathered construction and the sheets and edges of the flap valve are collapsible towards each other to form a seal when the chamber is pressurised.

25

The flap valve may be connected to the inner and outer sleeves at two locations along each side thereof whereby the region of the flap valve between the two locations can conform about a portion of the surgeon's hand or arm.

30

The inner and outer sleeves may be connected together by joins at specific locations so as to divide the inflatable chamber into upper and lower sub-chambers in fluid communication so that when pressurised, the sub-chambers

35

2183064

- 7 -

define at least one contiguous seal of surfaces forming the entry sealing means or a part thereof. The joins may comprise a plurality of opposed welds.

5 The exit sealing means is provided by the sheets of the sleeve being collapsible by gas pressure within the abdominal cavity of the patient at or adjacent, the distal edges of the sleeve.

10 A separate tensioning device may be provided in the distal region of the sleeve spaced from the distal edge to place the sheets under a generally transverse tension thereby creating a taut region across the sleeve operable as a further seal as part of the exit sealing means.

15 The tensioning device may comprise a pair of opposed arcuate bands operable to prevent retraction of the sleeve from the abdominal cavity. Wings may be provided at the side edges of the sleeve to provide anchoring points for
20 the opposed arcuate bands.

In a second aspect of the present invention, there is provided a surgical instrument comprising an elongate shaft, the dimensions of which are appropriately sized so
25 as to enable the shaft to be inserted and retracted through a trocar sleeve, a detachable instrumentation head and means for detachably connecting the instrumentation head to the shaft whereby the shaft can be moved through the trocar sleeve without the instrumentation head being
30 connected thereto and the instrumentation head can be detachably connected to the shaft within abdominal cavity of a patient.

Advantageously, the detachable head does not need to be of
35 a size necessary to enable it to pass through the trocar

- 8 -

sleeve. The detachable instrumentation head can be carried into the abdominal cavity in the surgeon's hand. This is envisaged both in the situation where the surgery is being carried out by minimally invasive surgery and
5 where surgery is by open surgery. In the case of minimally invasive surgery, access ports are described in the first aspect of the present invention which enable a surgeon's hand to enter the abdominal cavity for surgery. The detachable instrumentation head can be carried into
10 the abdominal cavity in the surgeon's hand.

In use, the surgeon can attach the instrumentation head to the shaft inside the abdominal cavity. This has the advantage that the instrument does not have to be
15 withdrawn from the abdominal cavity via the trocar sleeve and a different instrument inserted.

In a third aspect, of the present invention, there is provided a surgical device having at least one surface
20 provided with a strong adhesive adapted to be used in combination with a surgical incise drape having a low peel strength adhesive, in use the device being secured by the strong adhesive to a non-adhesive side of the drape.

25 Conveniently, the strong adhesive is applied to an area of the surgical device. Alternatively, the strong adhesive is provided on a site on the non-adhesive side of the incise drape.

30 Direct attachment of a strong adhesive to a patient is not desirable. If strong adhesives are used directly on a patient, it can cause damage to the patient's skin. They would be difficult to remove, and may cause negative reaction to the skin. The use of the incise drape will
35 cause a barrier between the patient and the strong

- 9 -

adhesive, at the same time allow a strong pull force at the attachment site of the drape.

According to an aspect of the present invention, there is provided an access port for use in surgery comprising:
5 an elongate sleeve of flexible material having an entry opening located at a proximal end of the sleeve and an exit opening located at a distal end of the sleeve,
an inflatable chamber surrounding the sleeve and
10 extending substantially coaxially therewith from the proximal end of the sleeve for a distance along the length of the sleeve, the inflatable chamber when inflated operating to collapse the sleeve to close the entry opening, the sleeve being attached to and surrounded by the
15 inflatable chamber with the sleeve extending through the inflatable chamber and outwardly therefrom to provide a projecting flexible sleeve portion extending outwardly from the inflatable chamber to the exit opening at the distal end of the sleeve whereby the projecting sleeve portion can be
20 inserted through an incision and into a patient's body cavity to provide a flexible sleeve portion adjacent to the exit opening within the body cavity free of a surrounding inflatable chamber.

25 According to another aspect of the present invention, there is provided an access port for use in surgery comprising:
an inflatable chamber having two, flexible, opposed substantially flat chamber inner sidewalls which collapse together into contact in response to pressure in the
30 inflatable chamber; the inner chamber sidewalls defining a passage through the inflatable chamber between a

-9a -

chamber entry opening and a chamber exit opening at a chamber exit end;

and a flexible non-inflatable extension section secured to the chamber exit end of the inflatable chamber in communication with the passage therethrough, the extension section being adapted to be inserted through an incision into a patient's body cavity to provide a flexible sleeve portion extending outwardly from the inflatable chamber; the extension section having a sleeve entry opening and a sleeve exit opening and two substantially flat, flexible sidewalls which form a flap valve at the sleeve exit opening.

According to a further aspect of the present invention, there is provided an access port device for use in surgery comprising a sleeve having an entry opening located at a proximal end of the sleeve and having an exit opening located at a distal end thereof for insertion into an incision made in a patient's body, the exit opening allowing access to the patient's body cavity, characterized in that the device includes exit opening sealing means provided by the sleeve being collapsible on itself by gas pressure within the abdominal cavity of the patient at or adjacent the distal edges of the sleeve, the sleeve being formed by sheets of flexible, gas impermeable, sterilizable, biocompatible material having joined side edges which are collapsible together by gas pressure within the abdominal cavity of the patient at or adjacent, the distal end of the sleeve so as to provide a seal, whereby when the patient's body cavity is inflated by gas, the exit sealing means prevents substantial leakage of gas from the patient's body cavity through the sleeve while providing access for a surgeon's hand or surgical instrument.

- 9b -

The invention will now be described more particularly with reference to the accompanying drawings, which show, by way of example only, various embodiments of surgical apparatus in accordance with the invention.

5

FIG. 1 is a perspective view, of a first embodiment of the access port device of the present invention, from above showing the proximal end of the device uppermost;

10 FIG. 2 is also a perspective view of the first embodiment from above, with a portion removed, for clarity;

FIG. 3 is a perspective view of the first embodiment from underneath;

15

FIG. 4 is a perspective view of a second embodiment of the access port of the present invention;

20 FIG. 5 is a perspective cut-away sectional view of the the second embodiment;

FIG. 6 is another perspective cut-away sectional view of the second embodiment;

25 FIG. 7 is another perspective view of the second embodiment;

FIG. 8 is a cross-sectional view of the second embodiment;

FIG. 9 is a cross-sectional view of the second

- 10 -

embodiment at right angles to the cross-sectional view of FIG. 8.

FIG. 10 is a schematic diagram of the access port of the invention without any transverse weld lines with the port shown in use, inserted in an incision site in a patient;

FIG. 11 is a schematic sectional elevation showing the access port in its inflated state;

10

FIG. 12 is a sectional view along line A-A of FIG. 11;

FIG. 13 is a schematic diagram of the access port of the invention showing the inclusion of a single weld line;

15

FIG. 14 is a sectional view along the line A-A of FIG. 13;

FIG. 15 is a schematic diagram of the access port of the invention showing the inclusion of two weld lines;

20

FIG. 16 is a sectional view along the line A-A of FIG. 15;

FIGS. 17, 18 and 19 are schematic diagrams of the access port of the invention showing the inclusion of a flap valve;

25

FIG. 20 is a front view of the third embodiment of the access port of the invention;

30

FIG. 21 is a sectional view of FIG. 20;

- 11 -

FIG. 22 is a perspective view of a third embodiment of the device;

5 FIG. 23 is a sectional view of FIG. 22;

FIG. 24 is a plan view of the third embodiment;

10 FIG. 25 is a plan view of the third embodiment showing the device from the distal end;

FIG. 26 is a more detailed view of the distal end of the third and fourth embodiments;

15 FIG. 27 is a plan view of the tensioning device;

FIG. 28 is a plan view of one side of the tensioning device;

20 FIG. 29 is a sectional view of a further embodiment of the access port;

25 FIG. 30 is a side view of the surgical instrument with the detachable instrumentation head shown in a detached position in which it is separated from the shaft of the surgical instrument; and

FIG. 31 is a side view of a trocar sleeve.

30 Referring to the FIGS. 1, 2 and 3 of the drawings, the first embodiment of the access port is indicated generally by reference numeral 1 and comprises a sleeve 2 having a proximal end 3 and a distal end 4. The proximal

- 11a -

end 3 of the sleeve 2 comprises a flange 5 and an inflatable chamber 6 having a entry opening (mouth) 7 through which a surgeon's hand may enter.

2183064

- 12 -

For surgery, an incision is made in the body of the patient, such an incision being made preferably along the muscle rather than across the muscle of the patient.

5 In order to assist in securely affixing the access port 1 to the patient's body, an adhesive sterile wrapping material may be adhered to the patient's body and an incision can made through the wrapping material. The distal end 4 of the sleeve 2 is inserted into the incision
10 and is pushed into the body cavity of the patient (which is not inflated at this stage) until the flange 5 contacts the wrapping material or the patient's skin, as the case may be if adhesive wrapping material is not used. The adhesive flange 5 is then adhered to the wrapping material
15 or the skin as the case may be, thereby securely affixing the access port 1 to the patient. The action of the muscle tissue around the incision causes the muscle tissue to press against the sleeve 2.

20 In order to seal the entry opening 7, gas is pumped into the inflatable chamber 6 causing it to inflate and thereby seal the entry opening 7. The patient's body cavity is then inflated. The gas used to inflate the inflatable chamber 7 may be pumped into the chamber 7 via a different
25 valve from that used to inflate the patient's body cavity.

Since fluid communication between the inflated chamber 6 and the patient's body cavity is possible when the access port 1 is in use, the pressure within the inflated chamber
30 6 is the same as the pressure within the patient's body cavity.

The portion of the sleeve 2 which in use, is located within the inflated abdominal cavity of the patient is
35 also subjected to an inwardly-directed pressure due to

- 13 -

the pressure existing in the patient's abdominal cavity and that portion of the sleeve collapses to form a seal.

When the surgeon desires to insert his gloved hand through
5 the access port, he pushes his gloved hand through the entry
opening 7 and down through the sleeve 2. As a surgeon forces
his arm through the entry opening 7, the now inflated
chamber 6 seals against his forearm. Since the seal is
10 formed about a larger surface area on the surgeon's forearm
than is the case in the prior art, the blood supply to the
surgeon's finger tips does not become restricted. The
surgeon pushes his gloved hand through the incision made in
the patient and the action of the muscle tissue at the
15 incision site has the effect of gripping the sleeve 2 and
sealing it against the surgeon's forearm. Therefore, there
are two seals in operation, namely, one seal which forms
around the surgeon's forearm due to the action of muscle
tissue at the incision site pressing and sealing the sleeve
2 against the surgeon's forearm and a second seal at the
20 entry opening 7 of the access port 1 where the inflated
chamber 6 seals about and against the surgeon's upper
forearm.

As the surgeon withdraws his hand out of the access port 1
25 of the invention, the muscle tissue around the incision site
clamps in on the sleeve 2 creating a seal against the sleeve
2 and as the surgeon withdraws his hand from the entry
opening 7, the seal is maintained.

30 A further advantage of the access port 1 of the present
invention is that manipulation of the access port can be
carried out using one hand. The prior art device requires
two hands in order for the surgeon to remove his "operating"
hand out of the sleeve. Furthermore, because the distal end
35 4 of the sleeve 2 is inside the patient's

- 14 -

body cavity, as the surgeon retracts his gloved hand, if his glove rubs against the side of the sleeve 2, the incision site does not come into contact with any infected tissue which might be carried upwardly from the operation site on the surgeon's hand or instrument.

It will be understood that the size of the access port can be varied to accommodate, for instance only one finger rather than the entire hand and arm of the surgeon and also may accommodate instruments. It is envisaged that it will be possible for the surgeon to take an instrument down through the sleeve while carrying the instrument in his hand.

The access port device may be manufactured from any flexible, gas impermeable, sterilisable, biocompatible material, for instance polyethylene.

Referring now to Figures 4 to 7, the access device in a second embodiment of the invention is indicated generally by the reference numeral 1' and comprises an inflatable chamber having an upper portion 12 and a lower portion 13 which are in fluid communication with each other and having an inlet pipe 14 for supplying gas to inflate both the upper portion 12 and lower portion 13 of the inflatable chamber. A separate pipe is used to inflate the patient's abdominal cavity. The device 1' also includes an adhesive flange 15 which can be adhered to the patient's skin or to the wrapping material, if used. The upper portion 12 of the chamber includes a lip 16 defining an entry opening 17 at the proximal end 18 of sleeve 21, leading to an exit opening 19 at the distal end 20 of the sleeve 21. The device 1' therefore has the advantage that the pressure in the inflated chamber can be controlled independently from the pressure in the patient's abdominal

- 15 -

cavity and therefore there can be a pressure differential between the pressure in the cavity and the pressure in the chamber of the access device 1'.

5 In order to use the device 1', the surgeon pushes his gloved hand through the entry opening 17 of the device 1' and down through the sleeve 21. For surgery, an incision is made in the body of the patient, such an incision preferably, being made along the muscle rather than across the muscle of the
10 patient. The distal end 20 of the sleeve 21 together with the lower portion 13 of the inflatable chamber are inserted into the body cavity of the patient (which is not yet inflated, at this stage) until the flange 15 contacts the patient's skin or to the wrapping securing means so as to
15 securely hold the access device 1' in place on the patient's body.

To use the device 1', gas is pumped into the inflatable, chamber via pipe 14 until both the upper portion 12 and the
20 lower portion 13 are fully inflated. The action of the muscle tissue around the incision causes the muscle tissue to press against the indented zone 22 defined between the now inflated portion 12 and inflated lower portion 13 of the chamber.

25 The patient's body cavity is then inflated. Since fluid communication is not possible between the patient's body cavity and the inflated chamber of device 1', the pressure within the inflated chamber 6 is not necessarily the same as
30 the pressure within the patient's body cavity.

The pressure in the chamber exerts an inward pressure on the sleeve and as shown in FIG. 6 the sleeve 21 along the area indicated by the letter A. Similarly, the portion of the
35 sleeve 21 which is in use, located within

2183064

- 16 -

the inflated abdominal cavity of the patient is also subjected to an inwardly-directed pressure due to the pressure existing in the patient's abdominal cavity and that portion of the sleeve also collapses as indicated by
5 reference numeral B on Figures 6 and 7 thus creating a seal at a distal end of the device.

The areas A and B respectively act as seals to prevent gas leakage from the patient. Furthermore, they bear against
10 the upper arm and lower arm respectively, of a surgeon, when the surgeon's hand is inserted through the sleeve and into the patient's abdominal cavity.

With reference to Figures 8 and 9, the access port
15 consists, nominally, of an outer sleeve 30 and an inner sleeve 31. The applied pressure has the effect of inflating the outer sleeve 30 whilst collapsing the inner sleeve 31 causing the inner sleeve 31 to form a seal in the access passage to the abdominal cavity. This
20 additional feature is intended to enhance the effectiveness of the seal, especially when the surgeon's arm has been removed from the sleeve.

The outer sleeve 30 is attached to the inner sleeve 31 at
25 two diametrically opposed locations 32. This has the effect of locally constraining the outer sleeve effectively causing two "dimples" to form in the outer sleeve. The resulting force F acts on the inner sleeve causing the two walls of the inner sleeve to be held in
30 contact. (This is similar in effect to inflating a balloon and stretching the neck of the balloon laterally instead of tying it off). Consequentially, the pressure of the gas in the abdominal cavity is required to overcome the pressure causing the inner sleeve to collapse plus the
35 closing effect of the Force F in order for leakage to

- 17 -

occur.

Referring now to Figures 10 to 27, a preferred embodiment of the access port will now be described. The access port of this third embodiment is based on and is a further development of the access port in the second embodiment. The access port in this embodiment is indicated generally by reference numeral 40. The access port 40 comprises an inner sleeve 41 and an outer sleeve 42. The outer sleeve 42 has a flange 44 provided at the distal end thereof.

Referring initially to Figures 10 to 12, the access port in the third embodiment, will be described. In use, the access port is adhesively attached to the exterior of a patient's abdominal wall, with or without an incise drape, so that the inner sleeve 41 projects into the abdominal cavity (See Figure 10). As usual with minimally invasive surgery procedures, the patient's abdomen is inflated with gas at pressure P as shown in Figure 11. The gas acts to expand the abdominal cavity. (Fluid pressure always acts perpendicular to the enclosing surfaces). Leakage of gas through the incision site causes gas to enter the chamber formed between the inner sleeve 41 and outer sleeve 42. Insulflation pressure can be introduced through a regulating valve (e.g. common stock-cock valve) attached to the outer sleeve 42.

The pressurised gas acts to inflate the outer sleeve 42 whilst, simultaneously, causing the opposing sides of the inner sleeve 41 to be forced into mutual contact. As shown in Figure 11, this results in the formation of a chamber 46 formed between the inner sleeve 41 and the outer sleeve 42 when inflated. This effectively seals the abdominal cavity from atmospheric pressure which exists outside the abdomen. The force keeping the inner sleeve

- 18 -

sealed is directly proportional to the pressure within the abdomen so the greater the gas pressure, the greater the force acting to create the seal.

5 As shown in Figure 11, when the device is inflated, the outer sleeve 42 nominally forms a cylinder. The diameter D of the cylinder is determined by the circumference C of the outer sleeve 42. The inner sleeve 41 is connected to diametrically opposite points on the outer sleeve 42. The
10 nominal diameter of the inner sleeve 41 is smaller than that of the outer sleeve 42, so the outer sleeve 42 is pulled towards the inner sleeve 41 to obtain the same diameter D when assembled. When insufflation pressure is introduced into the outer chamber, the outer chamber will
15 form a nominal cylinder of diameter D which will hold the inner sleeve 41 taut in the transverse plane.

Although, insufflation pressure is contained with the construction shown in Figure 11, difficulty is
20 experienced in inserting a hand and arm through the access passage since the inner sleeve 41 would cling to the surgeon's hand and arm. The surgeon must work his hand forward through the access passage against the action of the insufflation pressure acting on the inner
25 sleeve 41. This problem is overcome by the embodiment shown in Figures 13 and 14 in which the inner sleeve 41 is welded locally to the outer sleeve 42 along the weld lines 45 indicated in Figures 20 and 21. The effect of the weld line 45 is that, when inflated, the outer sleeve
30 42 pulls the inner sleeve 41 outward as shown in Figure 14. Since the weld line 45 does not extend the full width of either of the inner sleeve 41 or outer sleeve 42, gas can leak past the weld line as shown in Figure 13 thereby inflating the chamber between the inner sleeve and outer
35 sleeve resulting in the formation of upper sub-chamber 48

- 19 -

and lower sub-chamber 47. Since the upper sub-chamber 48 is subjected to insulflation pressure, the walls of the upper portion of the access passage are still held in mutual contact, forming a seal 100. Ideally the distance
5 between this upper seal 100 and the distal end of the inner sleeve 41 should be greater than the distance between the surgeon's wrist and finger tips thus ensuring that, with his arm inserted, the device forms a seal with his wrist before his fingers exit the distal end of the
10 inner sleeve 41.

Ease of access through the access port is enhanced by including further welded connections 45,45' between the inner sleeve and the outer sleeve 42 as shown in Figures
15 15 and 16. The inclusion of weld line 45' forms another line of seal indicated by the reference numeral 101 on Figures 15 and 16. This seal results in the formation of upper sub-chamber 48' and lower sub-chamber 47' between the inner sleeve 41 and the outer sleeve 42 and further
20 increases the rigidity of the device thereby enhancing ease of access for the surgeon's hand.

The effectiveness of the upper seal 100 is further enhanced by the provisions of a flap valve 50 having a
25 feathered edge construction (see Figures 17 - 24). The feathered edges are achieved by having the bottom end of the valve diameter larger than the inner diameter D so that the feathered edges have to be forced inwards to achieve the same diameter D. The edges allow the gas to
30 pass between the flap valve 50 and the inner sleeve 41 and enables the valve to operate in the desired way and to conform around the surgeon's arm. The feathered edge is only required to extend downward from the line of the upper seal 100. The attachment of the flap valve 50 to

- 20 -

the inner sleeve 41 is at positions A and B shown in Figure 18. This prevents the flap valve 50 from attaching to the inner sleeve which results in greater flexibility and hence conformity of the flap valve 50 to the surgeon's arm.

5 Finally, in the event that any gas leaks through this combination of seals, the outer sleeve 42 is tapered so that a final seal can be produced between the lip edge of the mouth of the device and the surgeon's forearm.

10 As indicated on Figure 11, the gas pressure necessary to keep the inner sleeve sealed tends to act in such a way that the access port would experience a force F which would cause the inner sleeve 41 to turn inside out. To overcome this
15 tendency the inner sleeve 40 and outer sleeve 42 are welded together along the line of their seams as shown in Figures 15 and 16. This overcomes the problem of the tendency to invert in respect of the proximal end of the inner sleeve 41. However, the distal end of inner sleeve 41 which
20 projects into the abdominal cavity may still demonstrate a tendency to turn inside out.

The tendency for the distal end of the inner sleeve 41 to invert under the action of the insufflation pressure is overcome by the inclusion of a resilient arcuate tensioning
25 device comprising arcuate bands 55 as shown in Figures 20 to 24, 26 and 27. The inner sleeve is modified by the addition of two wings 56. The material forming the inner sleeve is cut to include the wing like projections as indicated. The edges of the inner sleeve are welded as previously
30 described. The wings 56 are welded together with short linear welds. This has the effect of making the wings 56 stiff. These wings 56 provide an anchoring area for the tensioning device. The two arcuate bands 55

are welded together, through the wings 56, forming intimate joints. The arcuate bands 55, being compressed during assembly as indicated, apply a lateral pull to the inner sleeve 41 bringing the opposing faces of the inner sleeve 41 into mutual contact and hence forming an initial seal without the action of insulflation pressure. The eventual application of insulflation pressure results in the formation of further seals as described above. The geometry of the arcuate bands 55 is such that, when presented at right angles to the incision, it is possible for them to pass through the incision. Once in position within the abdomen, the bands 55 align themselves nominally parallel to the abdominal wall. In this attitude the insulflation pressure acts to invert the inner sleeve but since the arcuate bands 55 cannot pass through the incision, the inner sleeve 41 is restrained. Finally, the stiffness resulting from the short linear welds in the wings 56 combined with the fact that the arcuate bands are welded to the wings 56 keeps the wings 56 nominally perpendicular to the arcuate bands preventing inversion of the extreme distal end of the inner sleeve.

The use of the device in the third embodiment will now be described.

With or without an incise drape having been applied, a suitable incision is made in the patient's abdominal wall penetrating the peritoneum. The distal end of the access port 40 is presented to the incision site and the tensioning device is pressed through to the peritoneal cavity. The adhesive connection is made between the flange 44 and the patient's skin, or incise drape if the latter is being used. Obviously, all parts of the access port 40 are subject to atmospheric pressure at this stage. Assuming a gas delivery port is in situ, insulflation

-22-

pressure is applied to the patient's abdominal cavity. The action of the arcuate band on the inner sleeve in providing a lateral pull, effectively seals the inner sleeve. As the insulflation gas is introduced, leakage occurs at the
5 incision site causing sub-chambers 48", 47", 46 to fill with gas (see Figures 20 and 21). The device inflates as previously described and the inner sleeve forms the upper seal 100 and middle seal 101. The action of the gas on the distal end of the inner sleeve 41 further enhances the lower
10 seal 102. Since the pressure in cavity A is at atmospheric pressure, the flap valve 50 is not acting.

The surgeon then introduces his hand through the upper seal 100 and the middle seal 101. His hand passes through the
15 incision and towards the lower seal 102. At this point his wrist is in the upper seal 100. Further movement forward causes the lower seal 102 to open. Gas leaks past the surgeon's fingers and enters cavities B and A. The flap valve 50 is now subject to a pressure differential with
20 atmospheric pressure on one side and insulflation pressure on the other. This causes the feathered edge of the flap valve 50 to conform to the surgeon's forearm thus ensuring a seal 103. The lower seal 102 is now inactive. The surgeon can now move his hand further into the abdominal cavity,
25 usually until his hand has exited the distal end of the inner sleeve. The gas seal is still maintained at the upper seal 100. In the event that, through excessive movement of the surgeon's arm, gas should escape past the upper seal 100 the pressure in cavity A will drop below insulflation
30 pressure. If further leakage occurs at the middle seal 101 the pressure in cavity B will also drop below insulflation pressure. If this happens, a pressure differential exists across the lower seal which will

2183064

- 23 -

- become active causing the inner sleeve to conform to the surgeon's arm at the distal end of the inner sleeve thus effecting a seal there. If, by chance, the lower seal is opened due to further excessive movement then gas will leak, ultimately, into cavity A causing the upper seal to activate. Thus, it is clear that the device is configured so that the failure of one seal automatically initiates the activation of the other.
- 10 Assuming that the upper seal 100 is active, removal of the surgeon's hand occurs as follows. Retraction of the arm until the wrist is in the upper seal 100 will cause no effect except that the arcuate band will cause the lower seal 102 to be held closed by its spring action. Once the hand has entered the upper seal 100, a leak path will be formed allowing gas to escape to atmosphere.
- 15 Instantaneously, the pressure in cavities A and B will fall causing, once again, a pressure differential to exist across the lower seal which will become fully active. In the event that the lower seal 102 were the active seal at the commencement of the withdrawal, the passage of the hand through this seal would cause a leak path here causing the upper seal 100 to immediately become active.
- 20
- 25 With the surgeon's arm withdrawn, the distal end of the inner sleeve 41 will attempt to invert. However inversion is prevented by the fact that the arcuate bands 55 cannot pass through the incision in the orientation shown. As previously explained, the stiffness of the wings 56 on the inner sleeve 41 further act to prevent inversion. In the unlikely event that inversion does occur, the resulting leakage would cause the upper seal to automatically activate.
- 30
- 35 Removal of the device after surgery is relatively

straightforward. After insufflation pressure has been removed, and with the device flaccid, the adhesive band at the flange is broken. This permits the arcuate band to be reoriented to present its narrow edge to the incision. A gentle pull on the welded seam of the inner sleeve 41 will cause the end of the arcuate band 55 to exit the incision, where it can be gripped firmly and withdrawn.

The access port essentially consists of a flexible tube, fabricated from polymer film edge welded, and an adhesive coated flange also of flexible polymer film. The tube is partially inverted as shown in Figure 10(i) such that the end of the tube which is not attached to the flange projects beyond the flange. This configuration effectively forms the inner and the outer sleeves as described. For ease of manufacture, the two walls of the inner sleeve are made separate from the outer sleeves and welded to the outer sleeve, together with the material forming the feathered edge of the flap valve 50, along the lip edge. The flap valve 50 is manufactured by welding the two further pieces of polymer film which makes up the flap valve 50 inside the inner sleeve.

With reference to Figure 29, a fourth embodiment 110 of the access port device is shown, which is a two part construction, a lower portion 115 and an upper portion 120. Both portions 115, 120 have a flange 125 which can be joined together by an adhesive or other mechanism. The lower portion 115 is provided with a leak path 130 which can be opened after the portions 115 and 120 are joined by removing a peel tab (over the leak path). In all other respects the device is similar to the third embodiment of access port device already described.

Referring to Figures 30 and 31 of the drawings, the

- 25 -

surgical instrument of the second aspect of the present invention is indicated generally by reference numeral 201 and includes a handle 202 provided with a trigger 203 which is pivotally connected to the handle 202. The instrument 201
5 also includes an elongate shaft 204 and a detachable instrumentation head 205. The shaft 204 and instrumentation head are detachably connectable together by attachment means 206. As shown in the drawings, the instrumentation head 205 is provided with a stapling device. Obviously, any
10 particular alternative surgical instrument such as a forceps, for instance, may be provided on the instrumentation head 205.

In use, the shaft 204 of the surgical instrument 201 is
15 inserted into the valve (not shown) on the trocar sleeve which is indicated generally by reference numeral 210. The shaft 204 is pushed through the barrel 211 of the trocar sleeve 210 which is of approximately from 3 mm to 6 mm internal diameter. In the prior art, the internal diameter
20 of the trocar barrel and the shaft 204 is typically up to 15 mm in diameter so as to accommodate an instrument head of that size.

In use, the detachable instrumentation head 205 is held in
25 the hand of the surgeon and the appropriate instrumentation head 205 provided with the required instrument is connected to the shaft 204 by the attachment means 206. The trigger 203 is operated by the surgeon so as to control and manipulate the stapling device provided on the detachable
30 instrumentation head 205.

It is to be understood that the attachment means 206 is
variable as are the dimensions of the instrumentation head 205 since the latter is not restricted by the dimensions of
35 the trocar sleeve 211.

2183064

- 26 -

Reference is now made to the surgical incise drape device of the invention.

5 There are four general ways in which the incise drape can be used:

10 1. The invention may be used as a means of attachment of a device such as an access device or access port for use in minimally invasive surgery such as described above on which is applied a significant force from the gas pressure that is applied once pneumoperitoneum is established; or forces arising from the manipulation of those access ports from the hand or instruments.

15

2. It may be used as a means of attachment to make current devices such as the numerous cannula used in minimally invasive surgery leak free - in this instance the device can be made to fit over the current cannula with an adhesive flange that will stick to the drape. It would also serve the purpose of fixing those devices in place so that they do not slide through the trocar wound and be used when a surgeon desires to put into place a smaller cannula that the wound would allow.

25

3. Furthermore, the invention can be used as a means to apply an external pulling force on the patients skin and attached tissue (subcutaneous tissue, muscle, Peritoneum) for many purposes. One such purpose would be a gasless means to lift the abdominal wall to create a cavity similar to that created by pneumoperitoneum, or the gasless "laprolift" that uses an internal device to lift the abdominal wall for a gasless procedure. Another purpose would be lifting the abdominal cavity to allow the "first trocar" incision to make it safer. Also it could

35

2183064

- 27 -

be used as a tissue retractor, by pulling from the attachment point(s) of the drape on both sides of a surgical wound, etc.

5 4. The incise drape could be also used in a situation
with a combination of gas and pull requiring less gas
pressure. Similar to 3 above, a means of pulling on the
attachment point(s) is used to reduce the amount of gas
pressure required to make a cavity for the purpose of the
10 minimally invasive surgery procedures. By way of example
if one was to pull on the hand access port included in our
previous patent application, less gas pressure would be
required to fill the body cavity to produce the same space
that is made from pressure alone. As gas pressure has
15 some severe complications in selected patients, and is
often difficult to work with, this technique could be a
significant advantage in minimally invasive surgery, for
instance.

20 It will of course be understood that the invention is not
limited to the specific details described herein, which are
given by way of example only, and that various
modifications and alterations are possible within the scope
of the invention as defined in the appended claims.
25

CLAIMS

1. An access port for use in surgery comprising:
an elongate sleeve of flexible material having
5 an entry opening located at a proximal end of the sleeve
and an exit opening located at a distal end of said
sleeve,
an inflatable chamber surrounding said sleeve
and extending substantially coaxially therewith from the
10 proximal end of the sleeve for a distance along the
length of said sleeve, said inflatable chamber when
inflated operating to collapse said sleeve to close said
entry opening, said sleeve being attached to and
surrounded by said inflatable chamber with said sleeve
15 extending through said inflatable chamber and outwardly
therefrom to provide a projecting flexible sleeve portion
extending outwardly from the inflatable chamber to the
exit opening at the distal end of said sleeve whereby
said projecting sleeve portion can be inserted through an
20 incision and into a patient's body cavity to provide a
flexible sleeve portion adjacent to said exit opening
within said body cavity free of a surrounding inflatable
chamber.
- 25 2. An access port according to claim 1, wherein
the inflatable chamber is of generally "hour-glass"
profile defining an upper chamber and a lower chamber,
the lower chamber being insertable into the incision made
in the patient's body cavity.
- 30 3. An access port according to claim 1 wherein
said sleeve is formed with two opposed, substantially
flat sleeve sidewalls which collapse together into

- 29 -

contact in response to pressure in said inflatable chamber.

4. An access port according to claim 3 wherein
5 said entry opening and access opening are elongate openings defined by the sleeve sidewalls of said sleeve.

5. An access port according to claim 3 wherein the
10 sleeve sidewalls of said sleeve are formed to be wider adjacent to said exit opening to provide a wider section of said sleeve on said projecting flexible sleeve portion.

6. An access port according to claim 3 wherein the
15 sleeve sidewalls of said sleeve are formed to provide a flap valve at said exit opening.

7. An access port according to claim 6 wherein
20 resilient tensioning units are secured to the projecting sleeve portion of said sleeve to force said sleeve sidewalls into contact at said exit opening.

8. An access port according to claim 1 wherein a
25 flange is secured to said inflatable chamber in spaced relationship to the proximal end of said sleeve, for affixing the access port externally to a patient, said flange extending laterally relative to said projecting sleeve portion.

30 9. An access port according to claim 8 wherein said flange extends around but is spaced from said sleeve, said flange being oval in configuration.

- 30 -

10. An access port according to claim 1 wherein
said inflatable chamber includes chamber walls forming an
enclosed inflatable chamber that in use is not in fluid
communication with a patient's body cavity whereby the
5 pressure in the inflatable chamber may be different from
the pressure in the patient's body cavity, a pressure
inlet being mounted on a chamber wall of said
inflatable chamber.

10 11. An access port according to claim 1 wherein
said inflatable chamber extends to a lowermost chamber
end which surrounds and is spaced from said sleeve, the
projecting flexible sleeve portion extending outwardly
from said lowermost chamber end, and a laterally
15 extending flange is secured to said lowermost chamber end
for affixing the access port externally to a patient,
said flange being spaced from said sleeve.

12. An access port according to claim 2 wherein a
20 laterally extending flange is secured to said upper
chamber in spaced relationship to said lower chamber to
affix the access port externally to a patient.

13. An access port according to claim 1 wherein at
25 least a first flap valve is formed within said sleeve to
close said sleeve, said first flap valve being positioned
in spaced relationship to the proximal and distal ends of
said sleeve.

30 14. An access port according to claim 13 wherein
said sleeve is formed with two opposed substantially flat
sidewalls, the sidewalls of said sleeve being formed to
provide a second flap valve at said exit opening.

- 31 -

15. An access port according to claim 14 wherein
said first flap valve is positioned in spaced
relationship between said entry opening and said
5 projecting flexible sleeve portion.

16. An access port according to claim 15 wherein
said first flap valve is formed of first and second
sheets of flexible material each having a tethered end
10 and a free end, the tethered end of said first sheet
being connected to one of said sleeve sidewalls and the
tethered end of said second sheet being connected to the
remaining sleeve sidewall, the free ends of said sheets
engaging to close said sleeve at a point spaced from said
15 tethered ends in the direction of the distal end of said
sleeve.

17. An access port according to claim 3 wherein the
sleeve sidewalls of said sleeve are formed to provide a
20 flap valve at said exit opening.

18. An access port according to claim 17 wherein a
flange is secured to said inflatable chamber in spaced
relationship to the proximal end of said sleeve, for
25 affixing the access port externally to a patient, said
flange extending laterally relative to said projecting
sleeve portion.

19. An access port according to claim 1 wherein
30 said inflatable chamber includes chamber walls forming an
enclosed inflatable chamber that in use is not in fluid
communication with a patient's body cavity whereby the
pressure in the inflatable chamber may be different from

- 32 -

the pressure in the patient's body cavity, a pressure inlet being mounted on a chamber wall of said enclosed inflatable chamber.

5 20. An access port according to claim 19 wherein at least a first flap valve is formed within said sleeve to close said sleeve, said first flap valve being positioned in spaced relationship to the proximal and distal ends of said sleeve.

10

 21. An access port according to claim 1 wherein said sleeve forms an inner wall for said inflatable chamber, said inflatable chamber having a chamber outer wall spaced from said sleeve and connected to said sleeve at the proximal end of said sleeve.

15

 22. An access port according to claim 21 wherein opposite sides of said sleeve are connected to the chamber outer wall at a location spaced from said sleeve proximal end so as to divide the inflatable chamber into upper and lower subchambers in fluid communication.

20

 23. An access port according to claim 22 wherein the opposite sides of the sleeve are connected to the chamber outer wall at a plurality of opposite spaced locations.

25

 24. An access port according to claim 3 wherein said sleeve forms an inner wall for said inflatable chamber; said inflatable chamber having a chamber outer wall including two flat chamber sidewalls coextensive with said sleeve sidewalls.

30

- 33 -

25. An access port according to claim 24 wherein said sleeve sidewalls and chamber sidewalls are sheets of gas impermeable flexible material bonded at their common side edges and proximal ends.

5

26. An access port according to claim 24 wherein the sleeve sidewalls of said sleeve are formed to provide a flap valve at said exit opening.

10

27. An access port according to claim 26 wherein at least a first flap valve is formed within said sleeve to close said sleeve, said first flap valve being positioned in spaced relationship to the proximal and distal ends of said sleeve.

15

28. An access port according to claim 27 wherein opposite sides of said sleeve are connected to the chamber outer wall at a location spaced from said sleeve proximal end so as to divide the inflatable chamber into upper and lower subchambers in fluid communication.

20

29. An access port according to claim 28 wherein a flange is secured to said inflatable chamber in spaced relationship to the proximal end of said sleeve, for affixing the access port externally to a patient, said flange extending laterally relative to said projecting sleeve portion.

25

30. An access port according to claim 29 wherein the sleeve sidewalls of said sleeve are formed to be wider adjacent to said exit opening to provide a wider section of said sleeve on said projecting flexible sleeve portion.

30

- 34 -

31. An access port according to claim 30 wherein resilient tensioning units are secured to the projecting sleeve portion of said sleeve to force said sleeve sidewalls into contact at said exit opening.

32. An access port for use in surgery comprising:
an inflatable chamber having two, flexible, opposed substantially flat chamber inner sidewalls which collapse together into contact in response to pressure in said inflatable chamber; said inner chamber sidewalls defining a passage through said inflatable chamber between a chamber entry opening and a chamber exit opening at a chamber exit end;

and a flexible non-inflatable extension section secured to the chamber exit end of said inflatable chamber in communication with the passage therethrough, said extension section being adapted to be inserted through an incision into a patient's body cavity to provide a flexible sleeve portion extending outwardly from the inflatable chamber; said extension section having a sleeve entry opening and a sleeve exit opening and two substantially flat, flexible sidewalls which form a flap valve at said sleeve exit opening.

25

33. An access port according to claim 32 wherein the inner chamber sidewalls form a second flap valve at said chamber exit.

30

34. An access port according to claim 33 wherein a laterally projecting chamber flange is connected to said inflatable chamber to surround said chamber exit opening and a laterally projecting extension section flange

- 35 -

is secured to said extension section to surround said sleeve entry opening, said chamber and extension flanges being secured together.

5 35. An access port device for use in surgery comprising a sleeve having an entry opening located at a proximal end of the sleeve and having an exit opening located at a distal end thereof for insertion into an incision made in a patient's body, the exit opening
10 allowing access to the patient's body cavity, characterized in that the device includes exit opening sealing means provided by the sleeve being collapsible on itself by gas pressure within the abdominal cavity of the patient at or adjacent the distal edges of the sleeve,
15 the sleeve being formed by sheets of flexible, gas impermeable, sterilizable, biocompatible material having joined side edges which are collapsible together by gas pressure within the abdominal cavity of the patient at or adjacent, the distal end of the sleeve so as to provide a
20 seal, whereby when the patient's body cavity is inflated by gas, the exit sealing means prevents substantial leakage of gas from the patient's body cavity through the sleeve while providing access for a surgeon's hand or surgical instrument.

25

 36. An access port according to claim 35 having entry sealing means for sealing the sleeve in a region adjacent to the entry opening, whereby when the patient's body cavity is inflated by gas, the entry sealing means
30 assists in preventing substantial leakage of gas from the patient's body cavity while providing access for a surgeon's hand while sealing about a surgeon's arm which extends outside the access port device.

- 36 -

37. An access port according to claim 36, wherein the entry sealing means comprises an inflatable chamber arranged in surrounding relation to the sleeve and
5 capable of exerting a pressure on the sleeve causing at least a portion of it to contract thereby sealing the entry opening.

38. An access port according to claim 37 in which a
10 separate tensioning device is provided adjacent to the distal end of the sleeve spaced from the exit opening to place the sheets forming the sleeve under a generally transverse tension thereby creating a taut region across the sleeve operable as a further seal as part of the exit
15 sealing means.

39. An access port according to claim 38 in which the tensioning device comprises a pair of opposed arcuate bands operable to prevent retraction of the sleeve from
20 the abdominal cavity.

40. An access port according to claim 39 in which laterally extending wings are provided at the side edges of the sleeve to provide anchoring points for the opposed
25 arcuate bands.

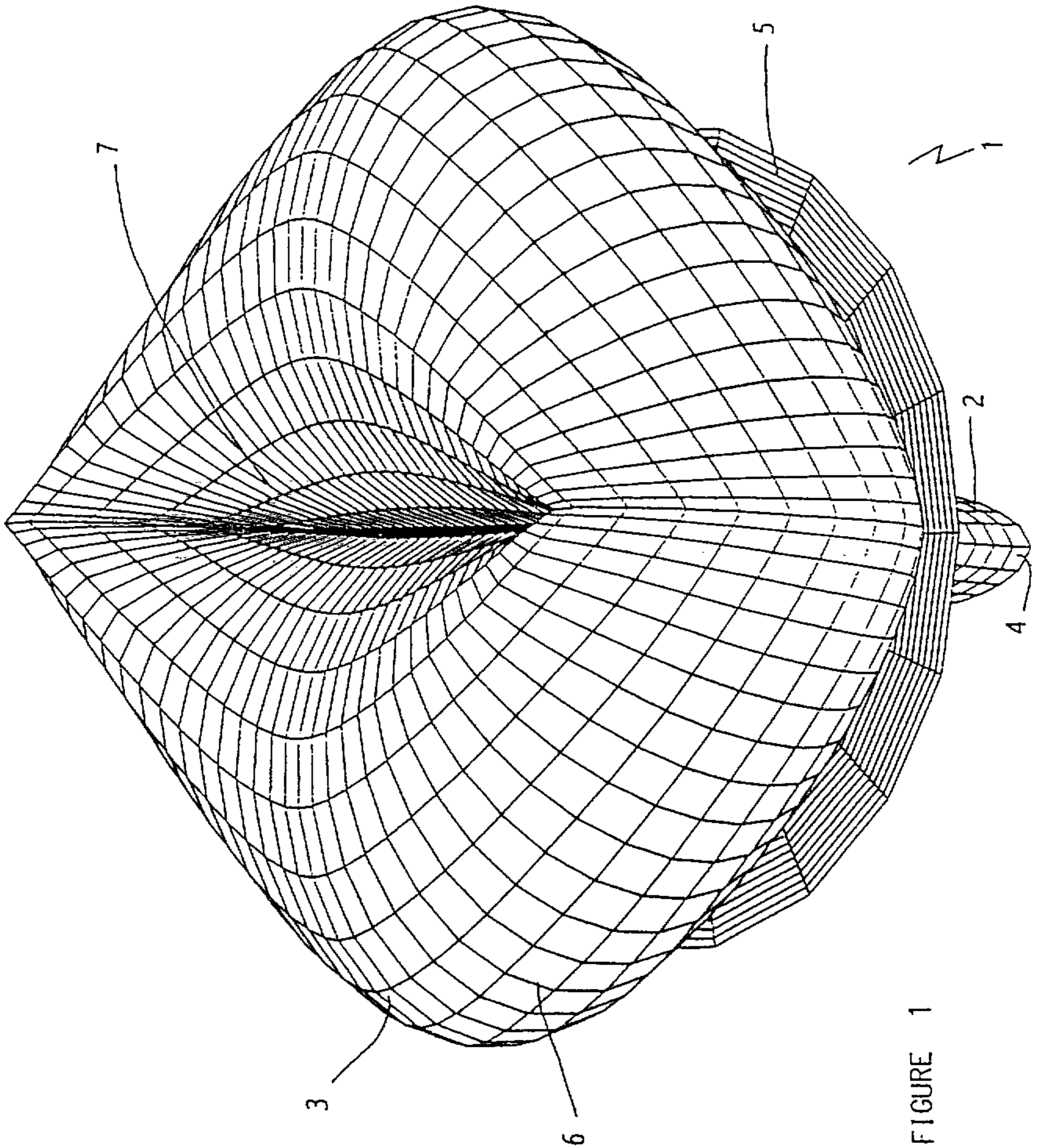

FIGURE 1

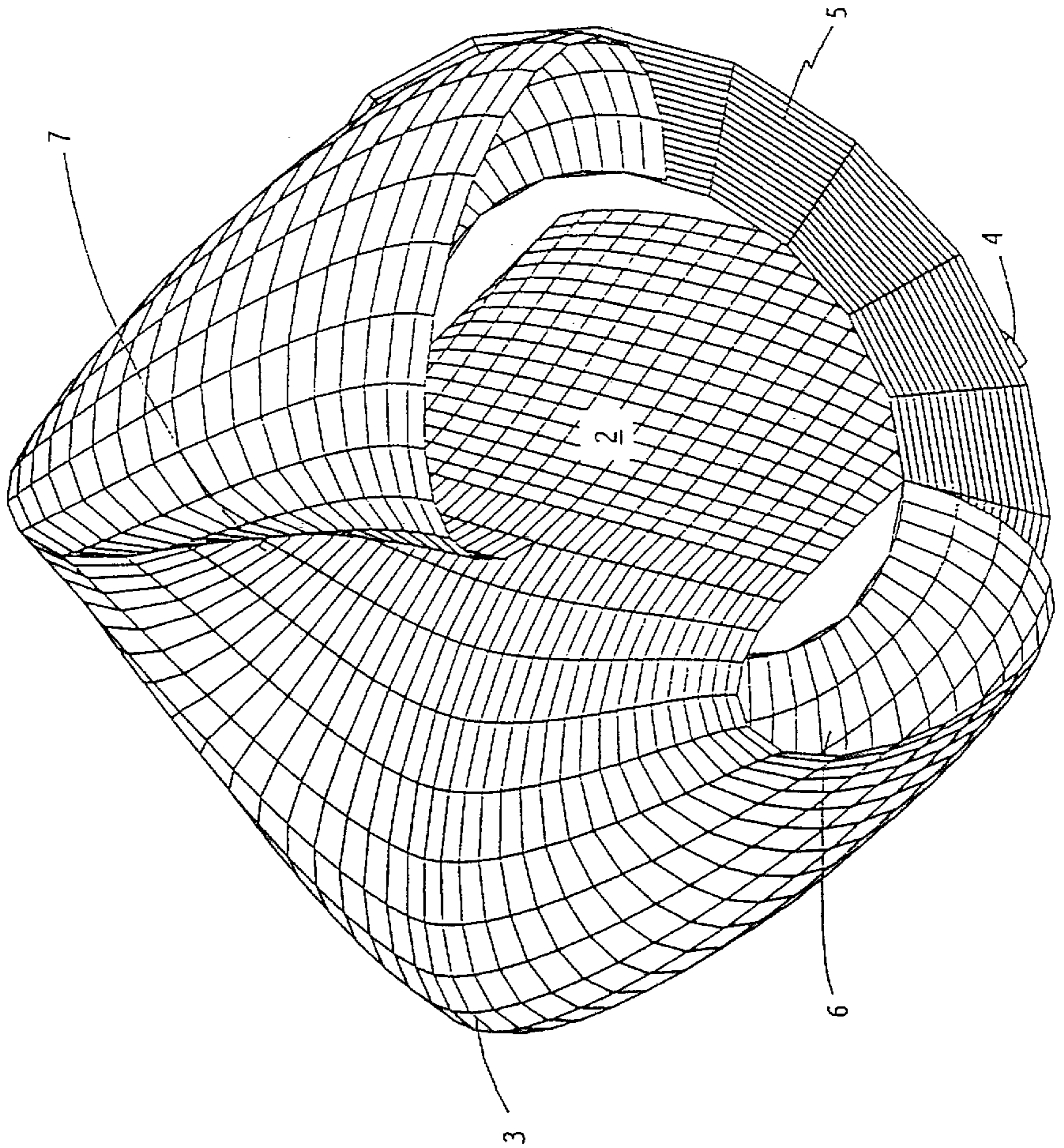

FIGURE 2

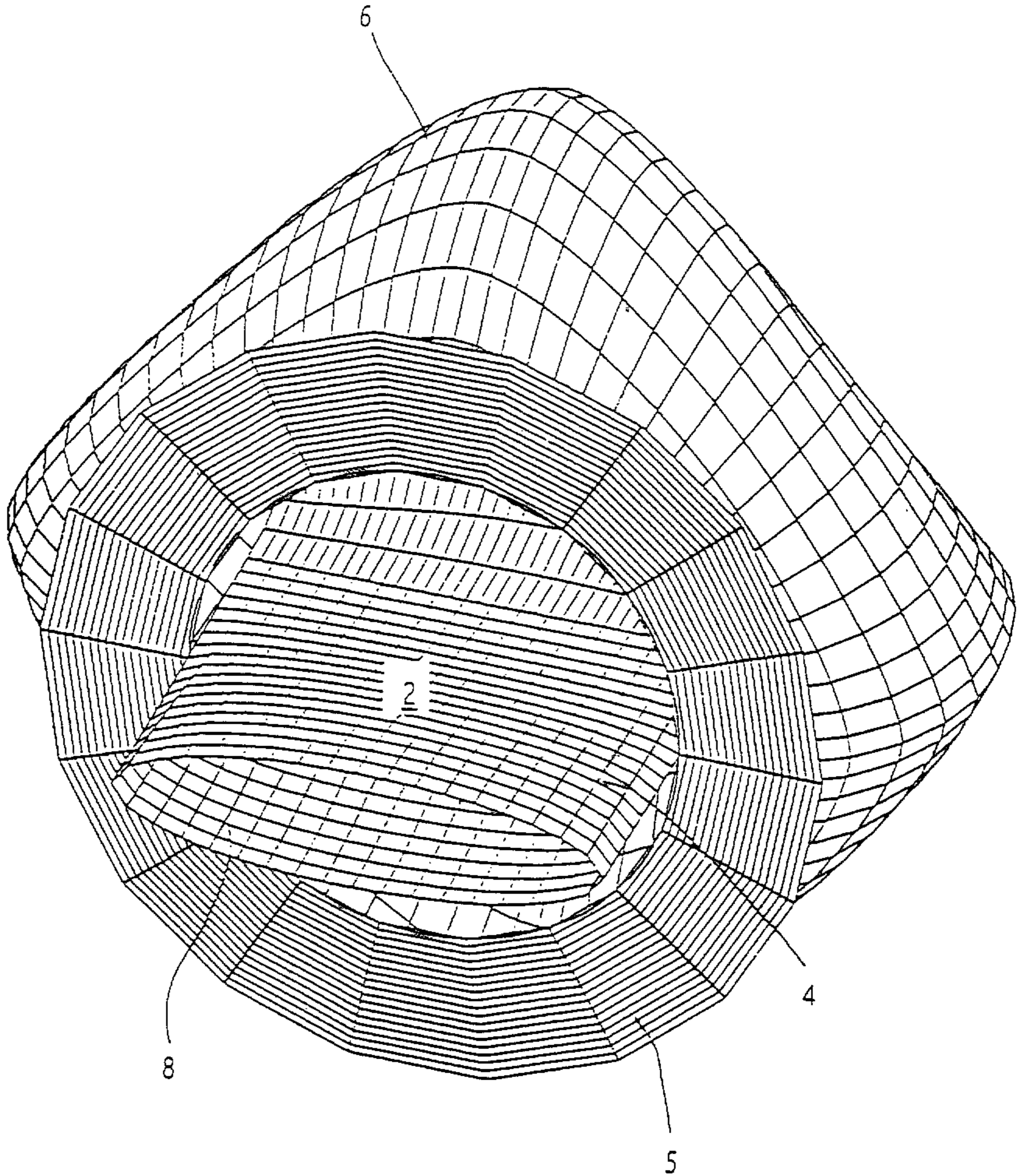

FIGURE 3

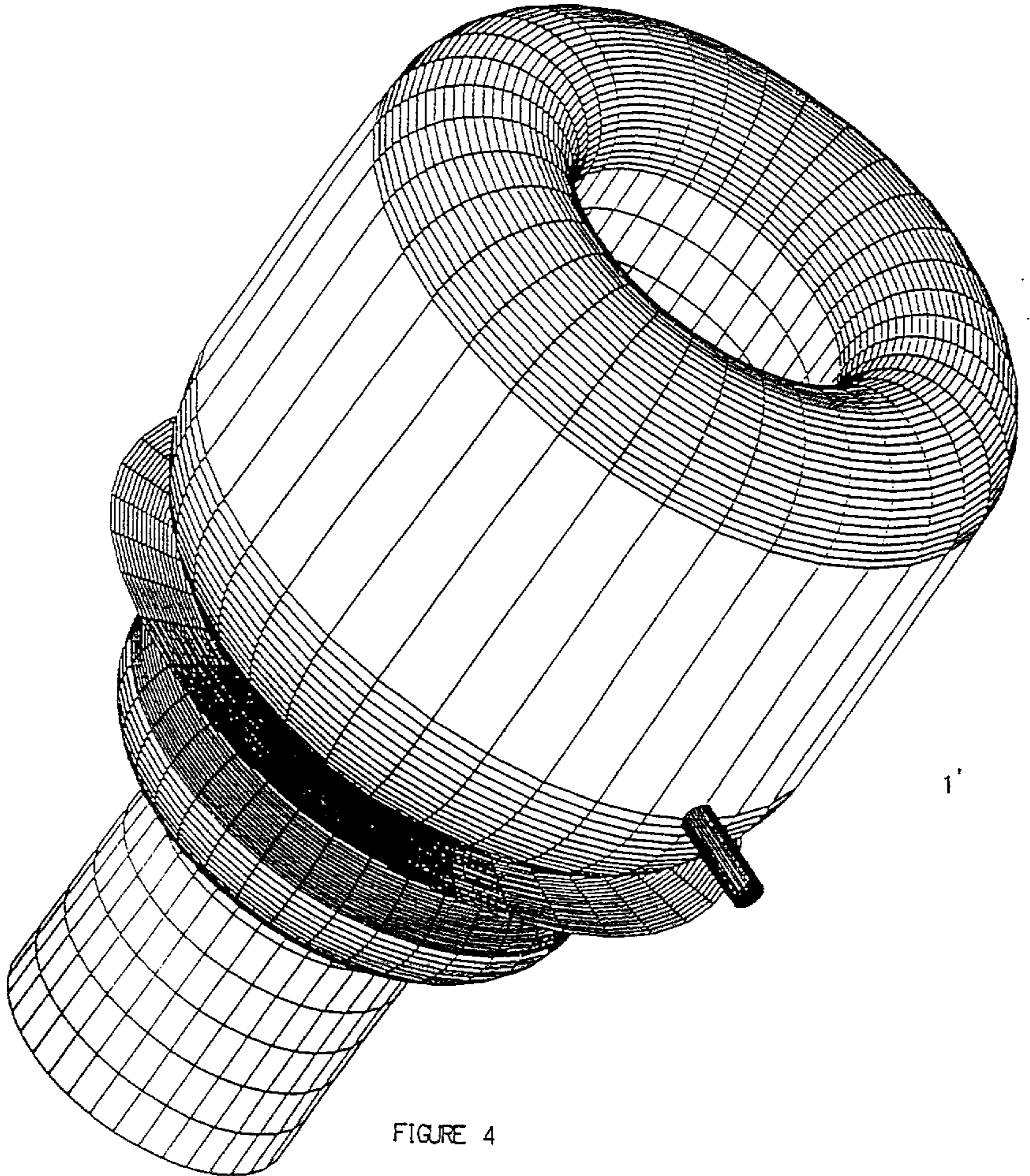

FIGURE 4

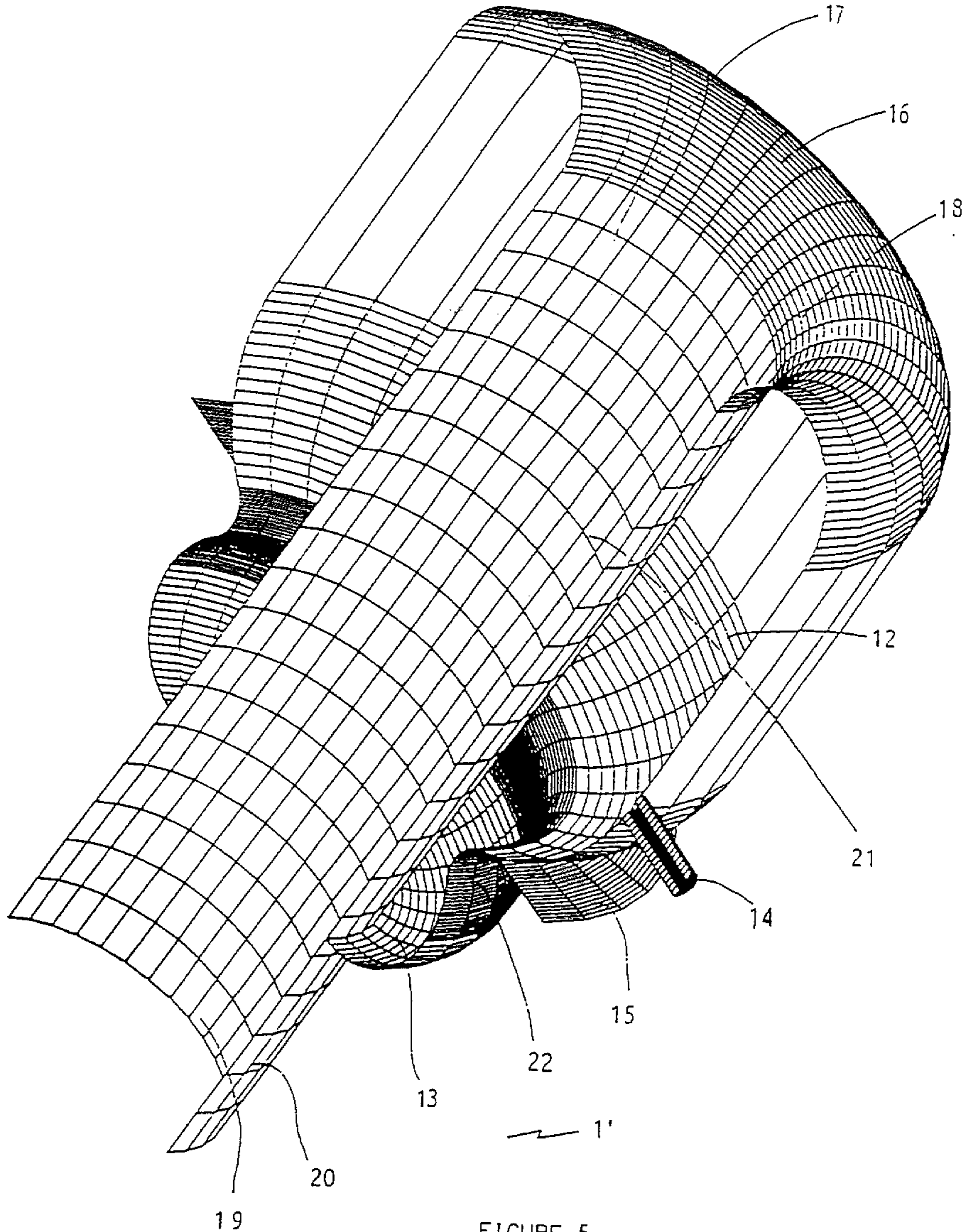

FIGURE 5

SUBSTITUTE SHEET

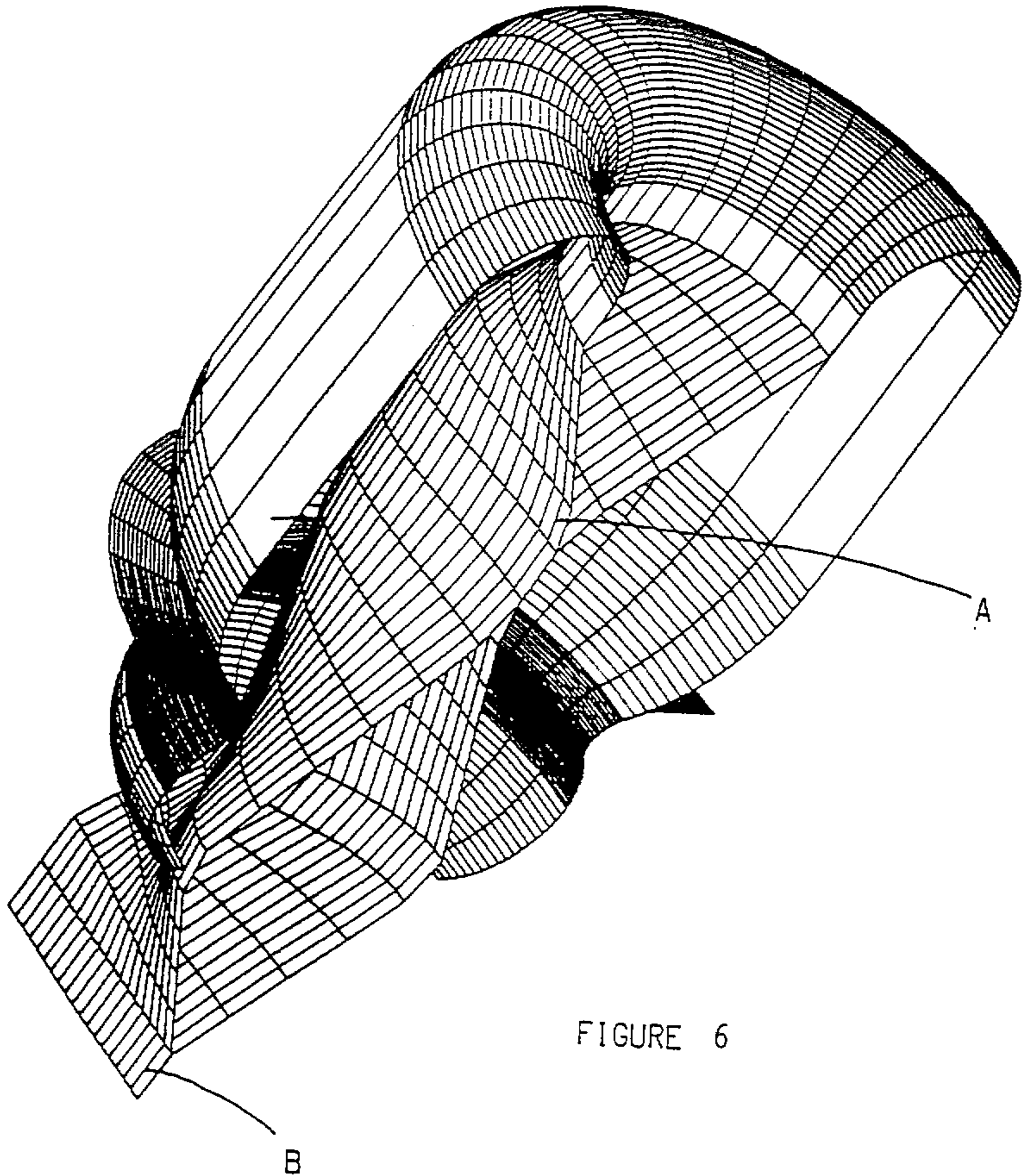

FIGURE 6

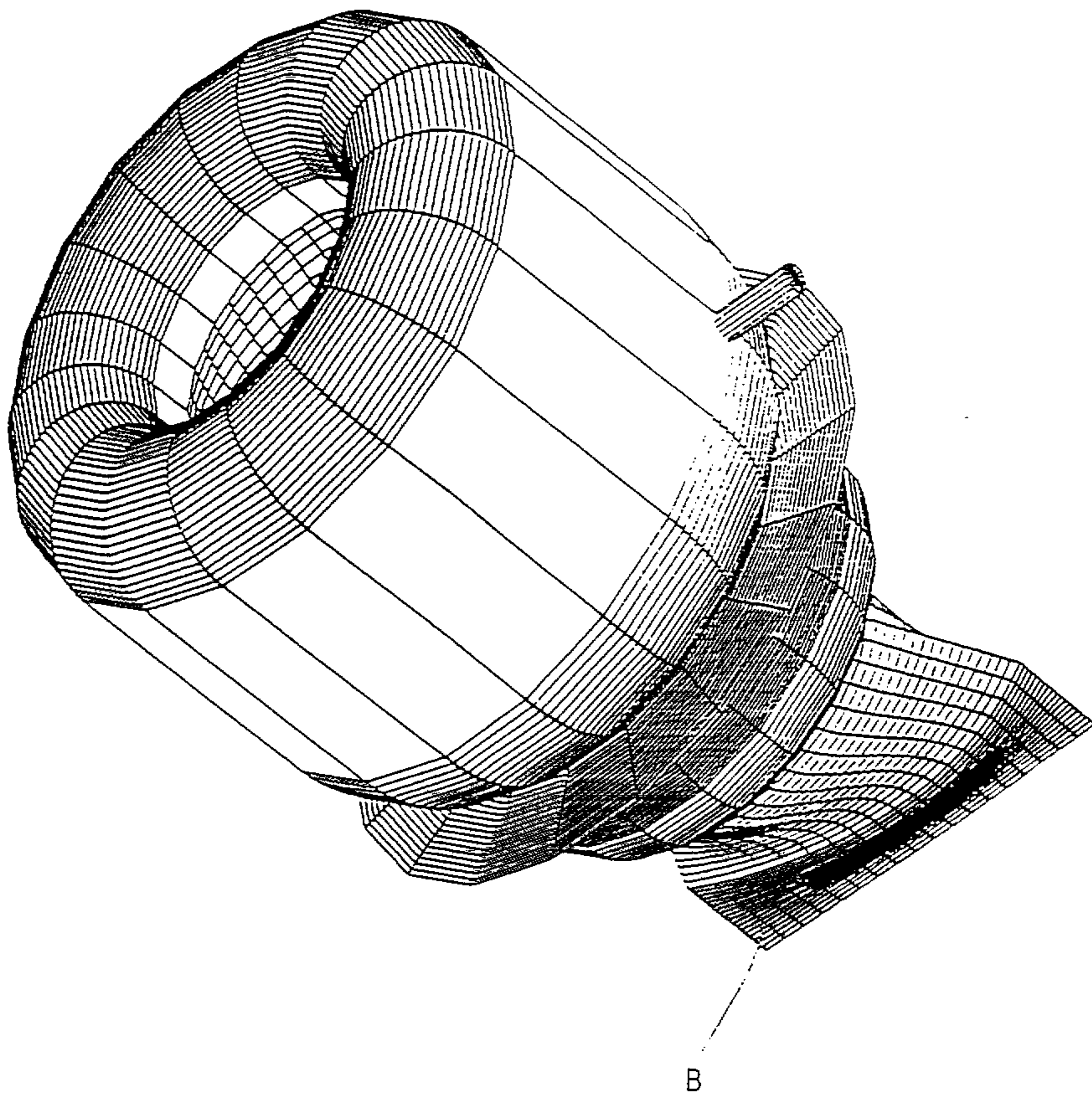

FIGURE 7

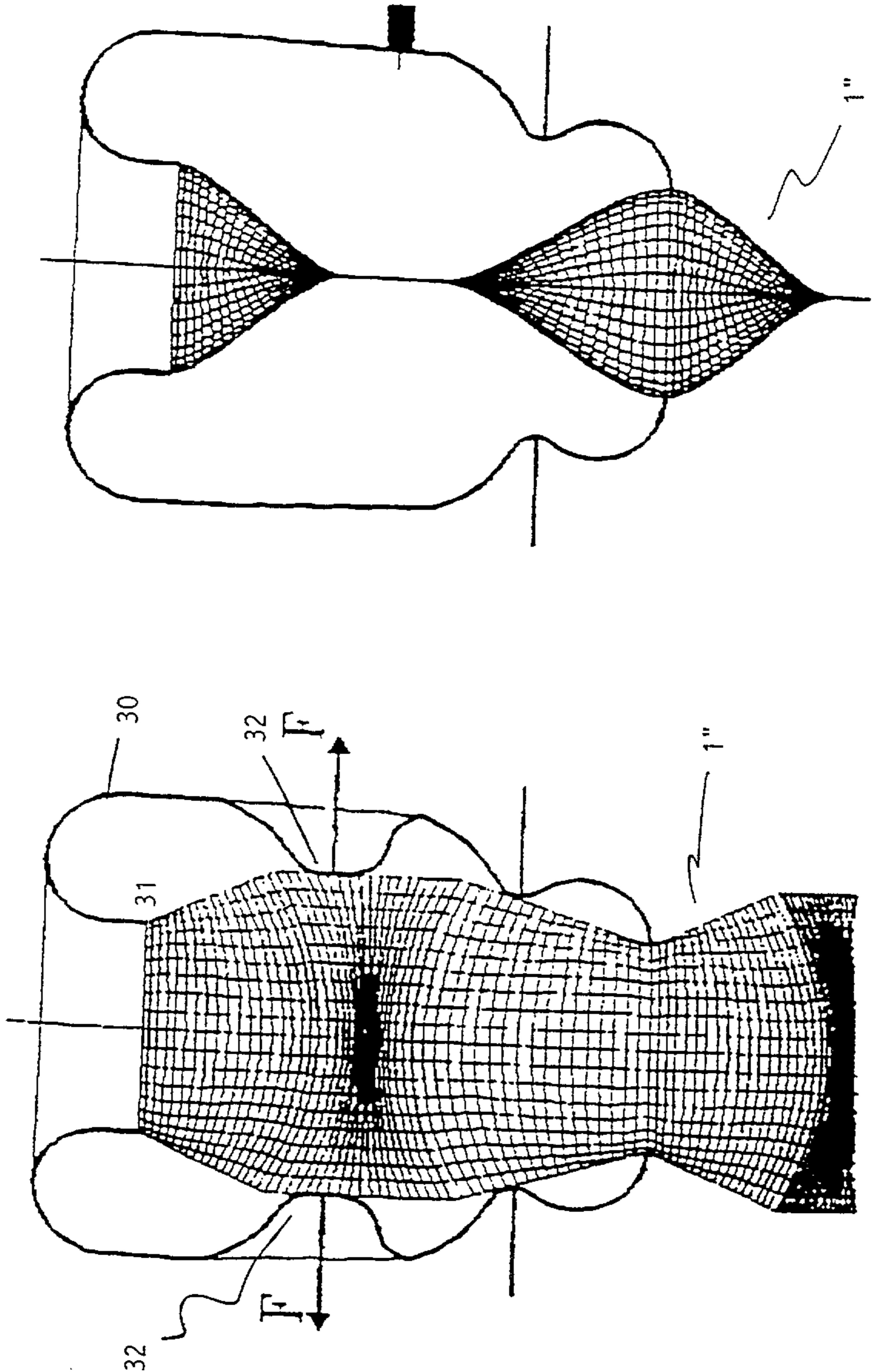

FIGURE 9

FIGURE 8

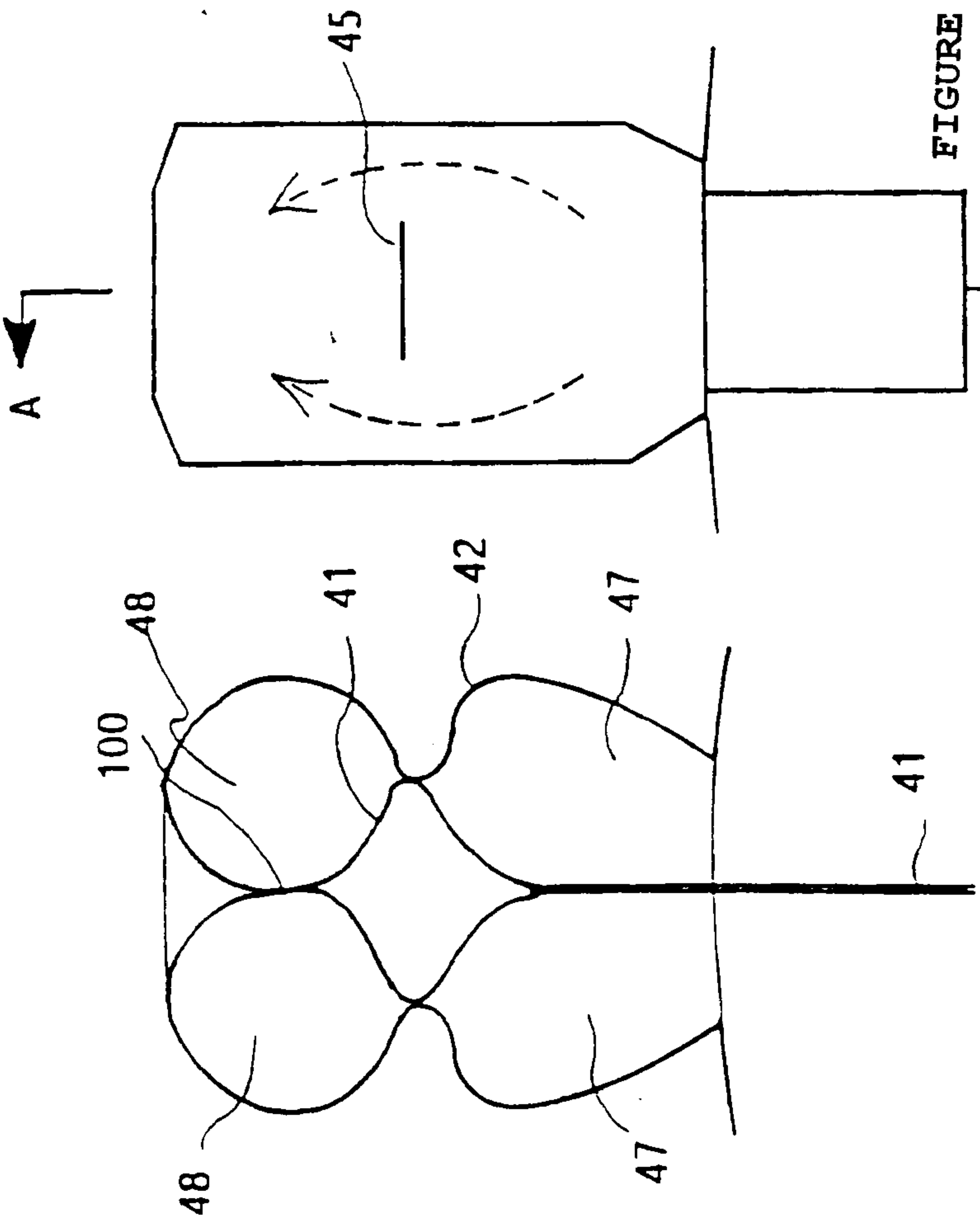

FIGURE 10

FIGURE 13

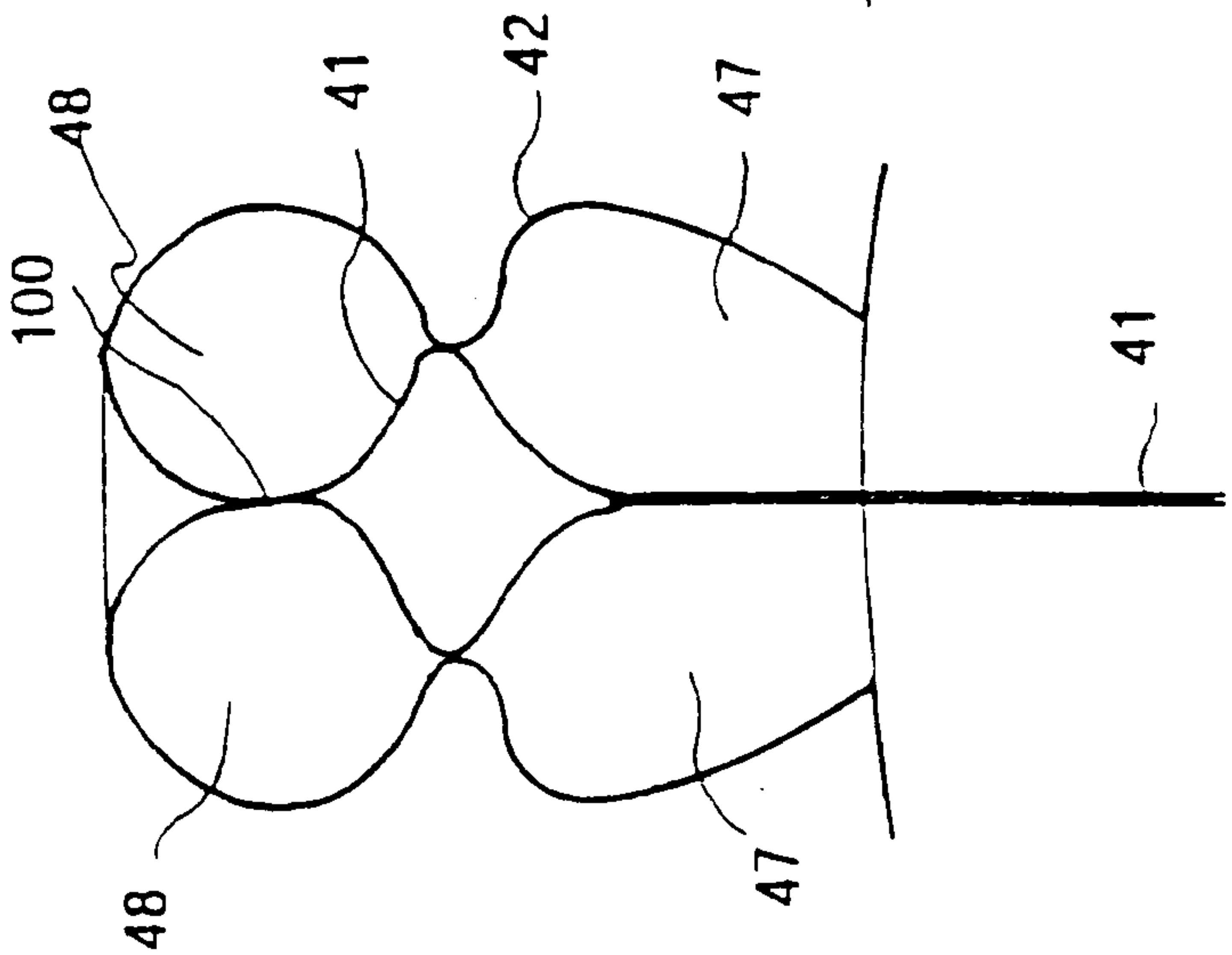

FIGURE 11

FIGURE 14

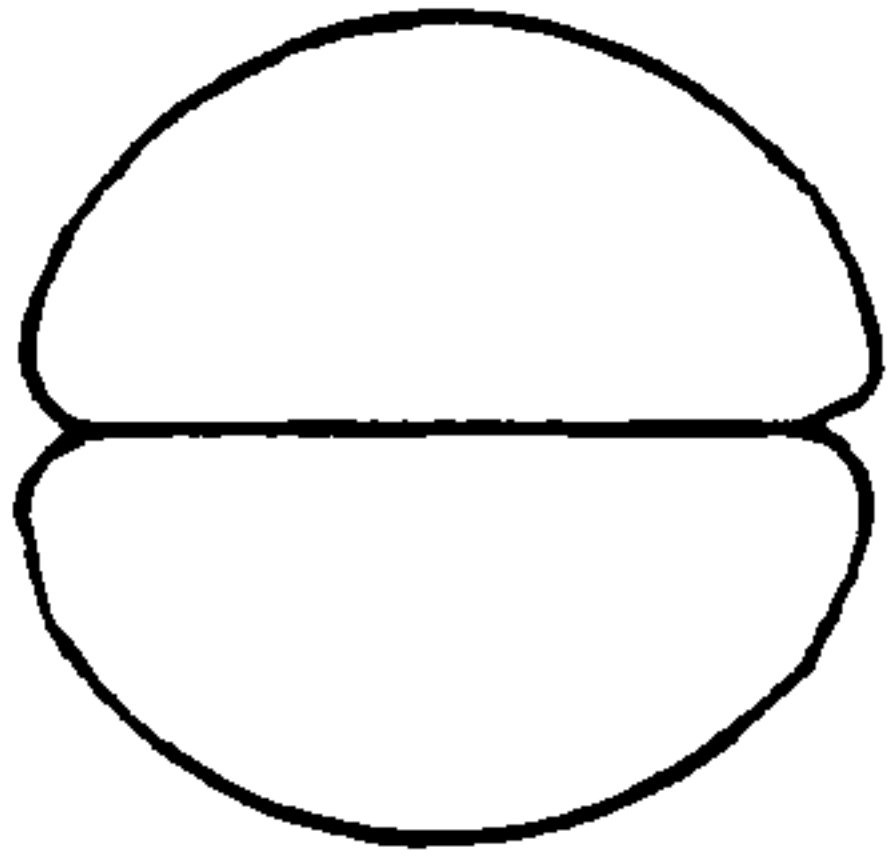

FIGURE 12

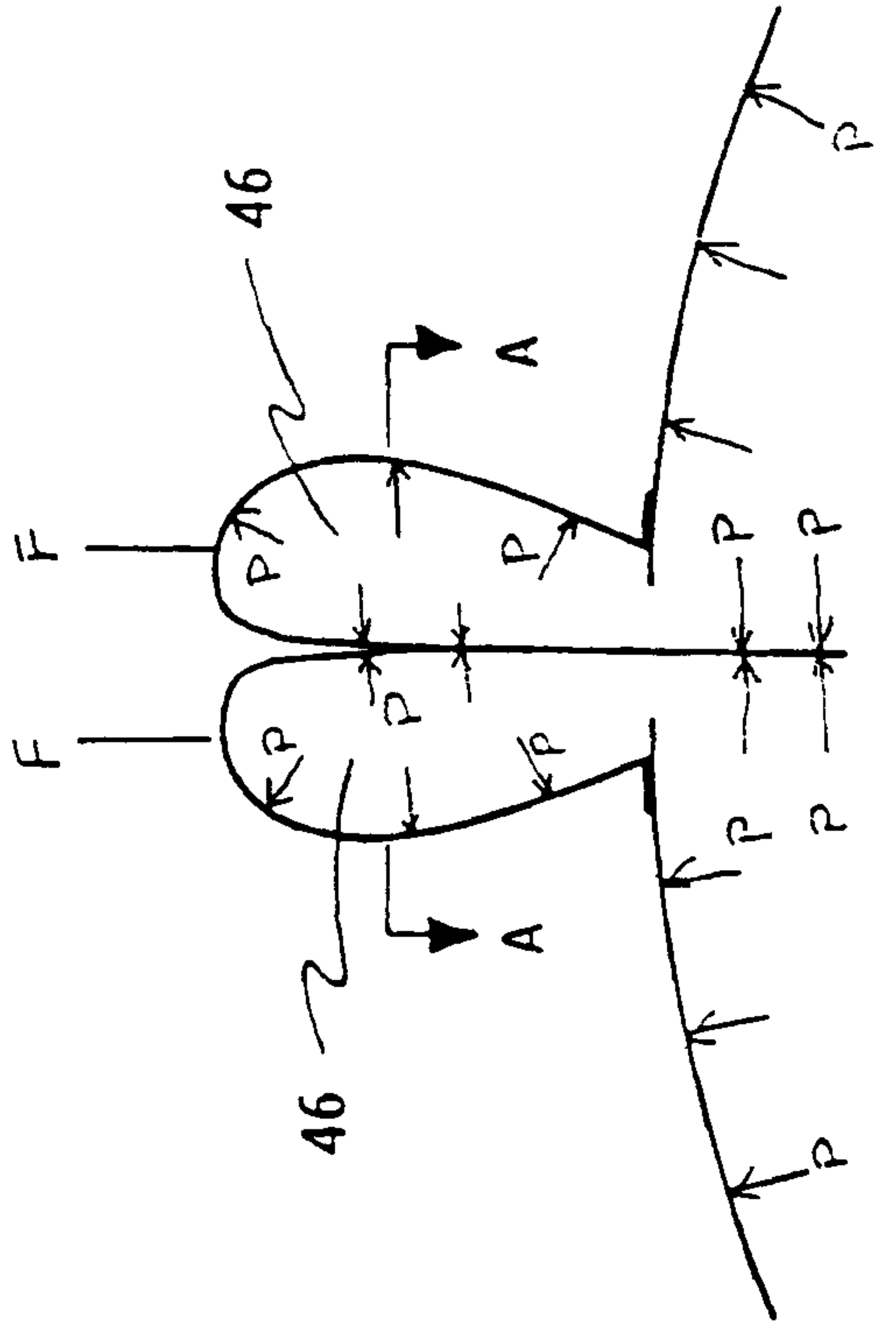

FIGURE 13

FIGURE 11

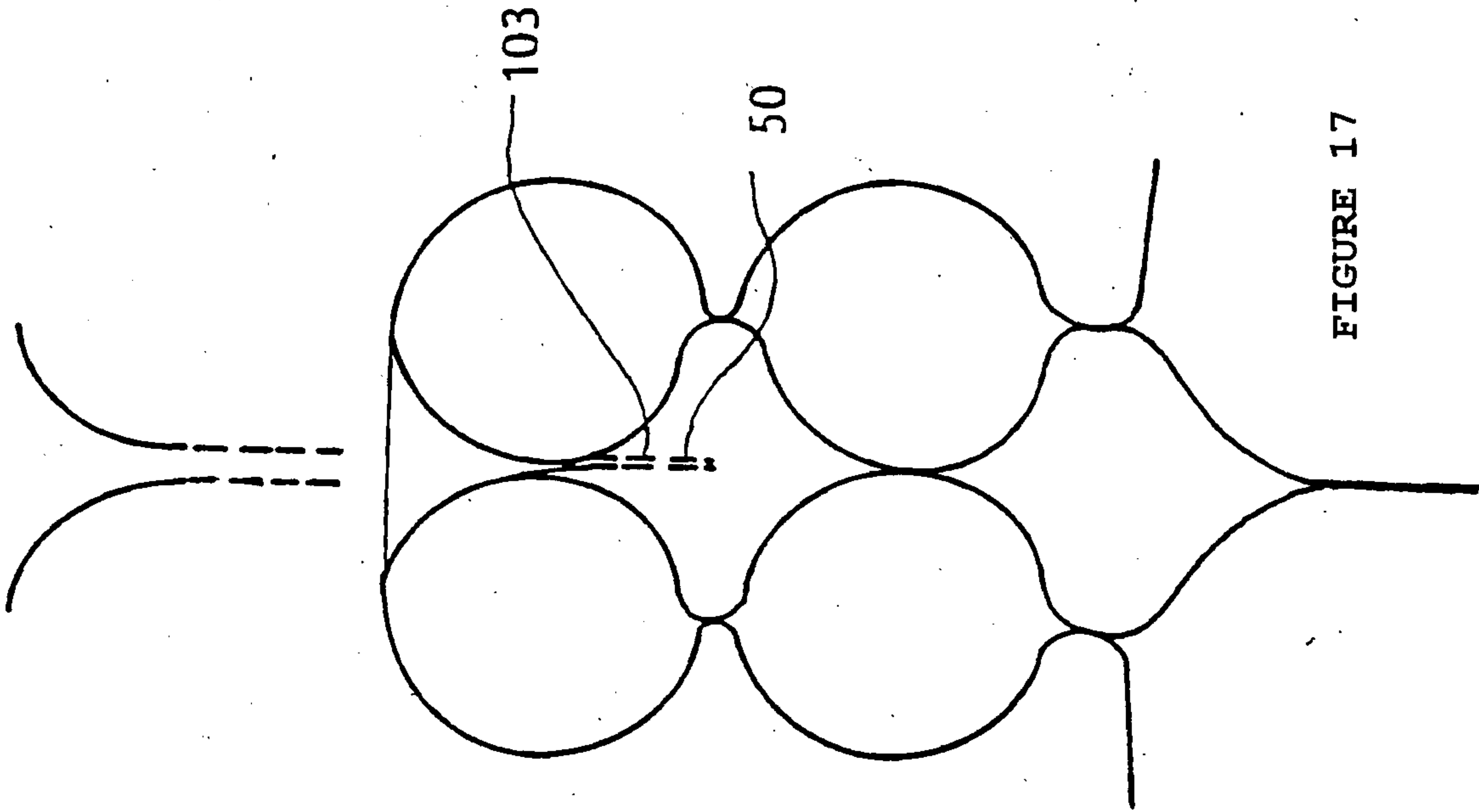

FIGURE 17

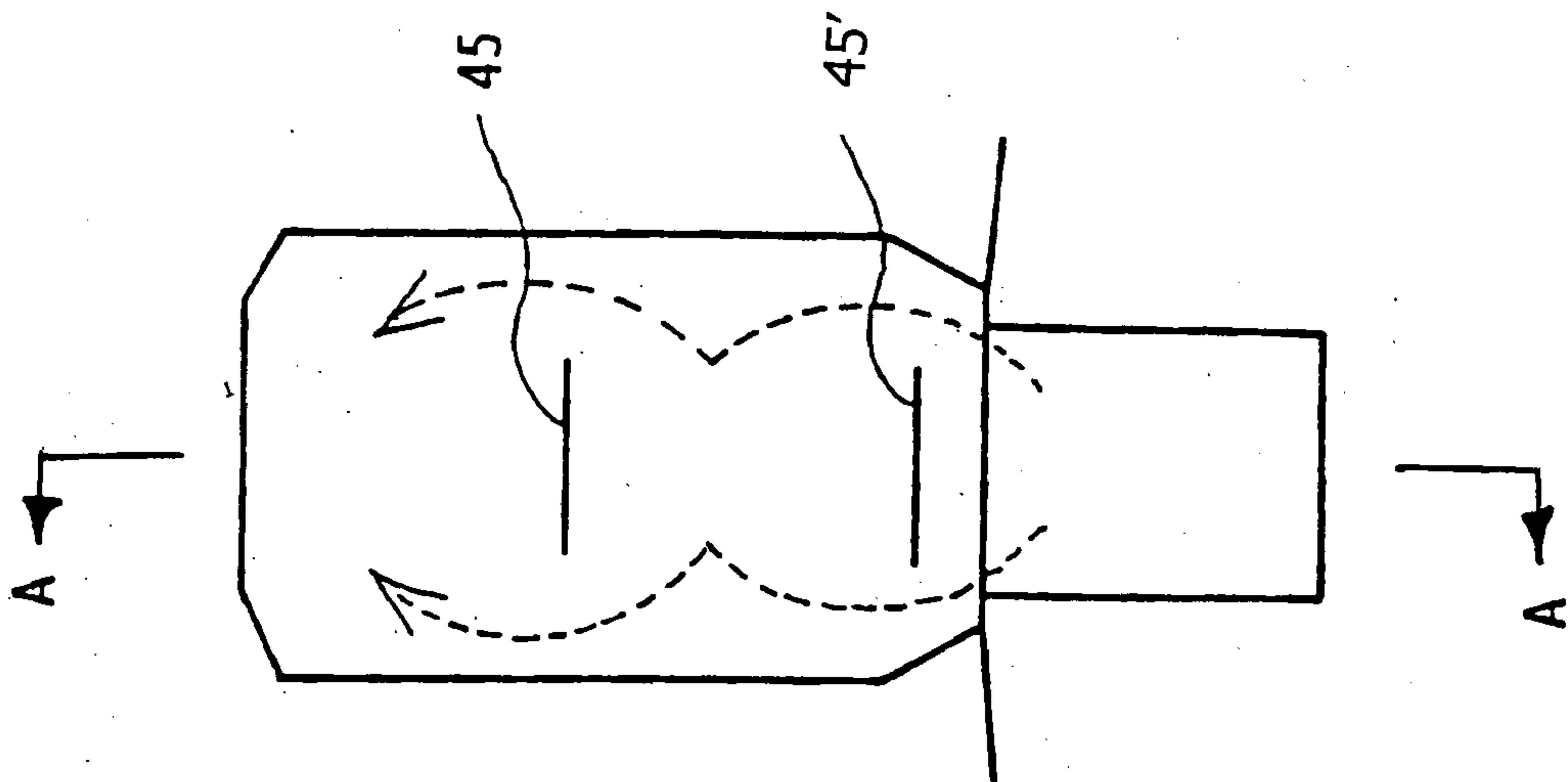

FIGURE 15

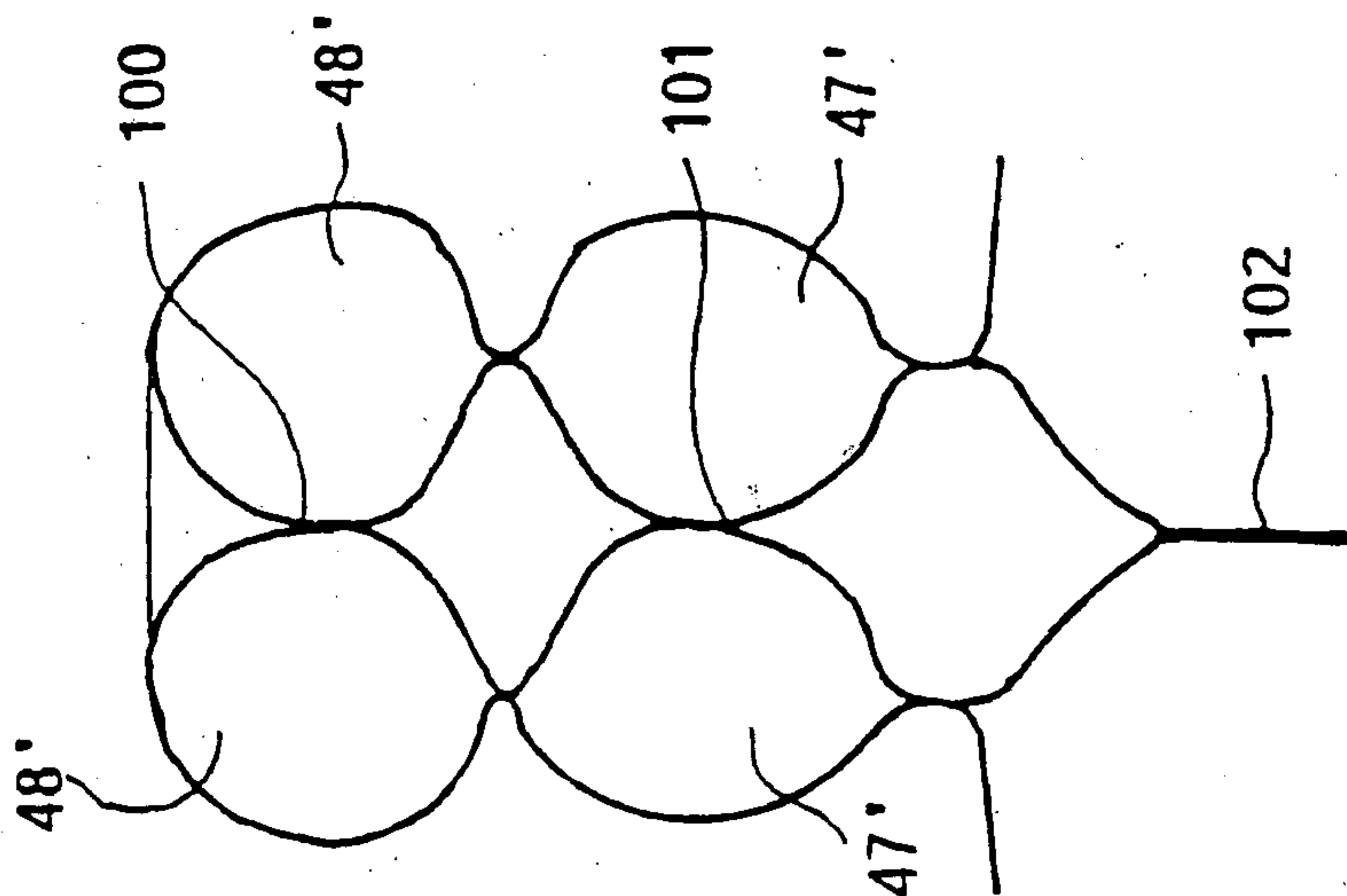

FIGURE 16

11/18

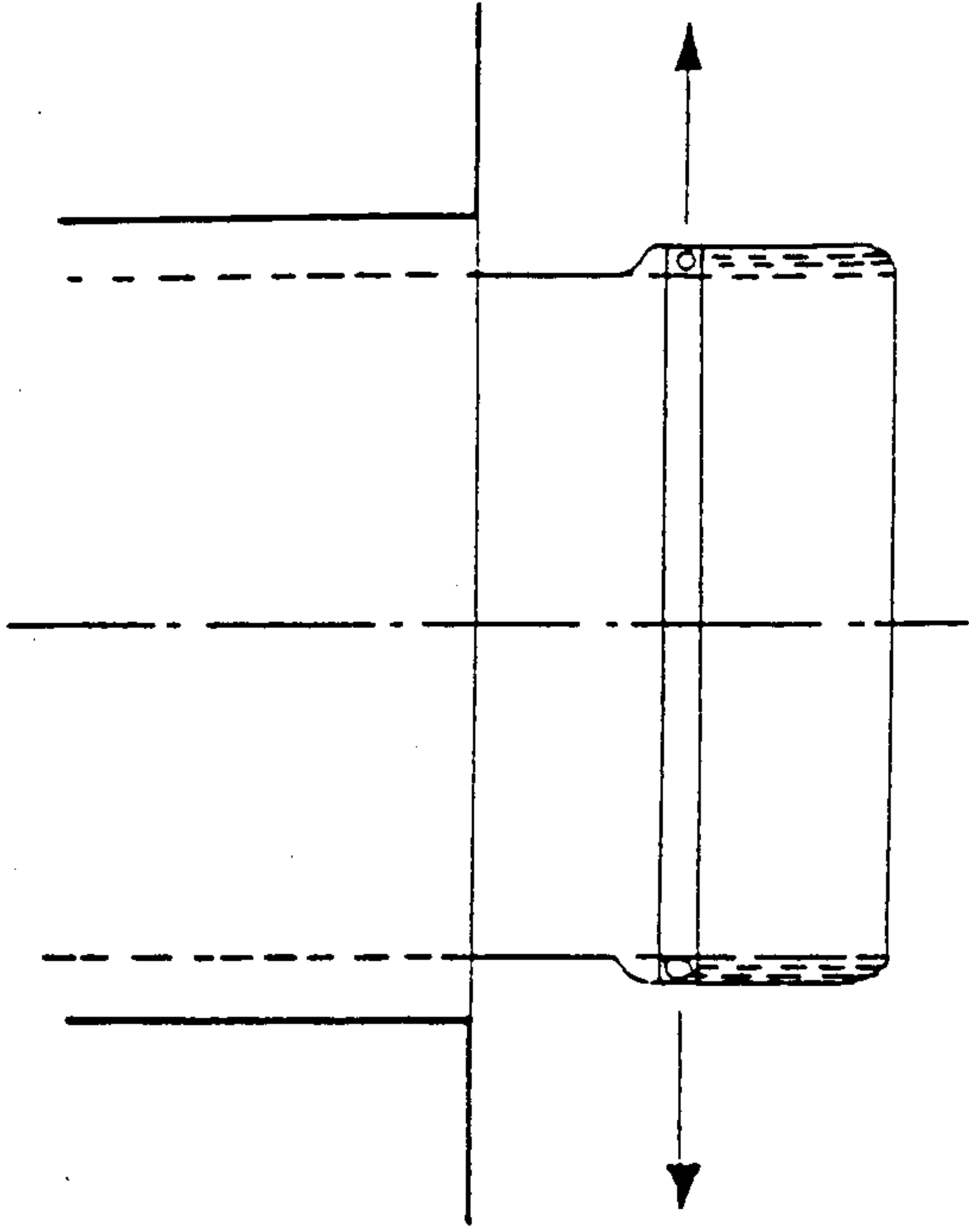

FIGURE 26

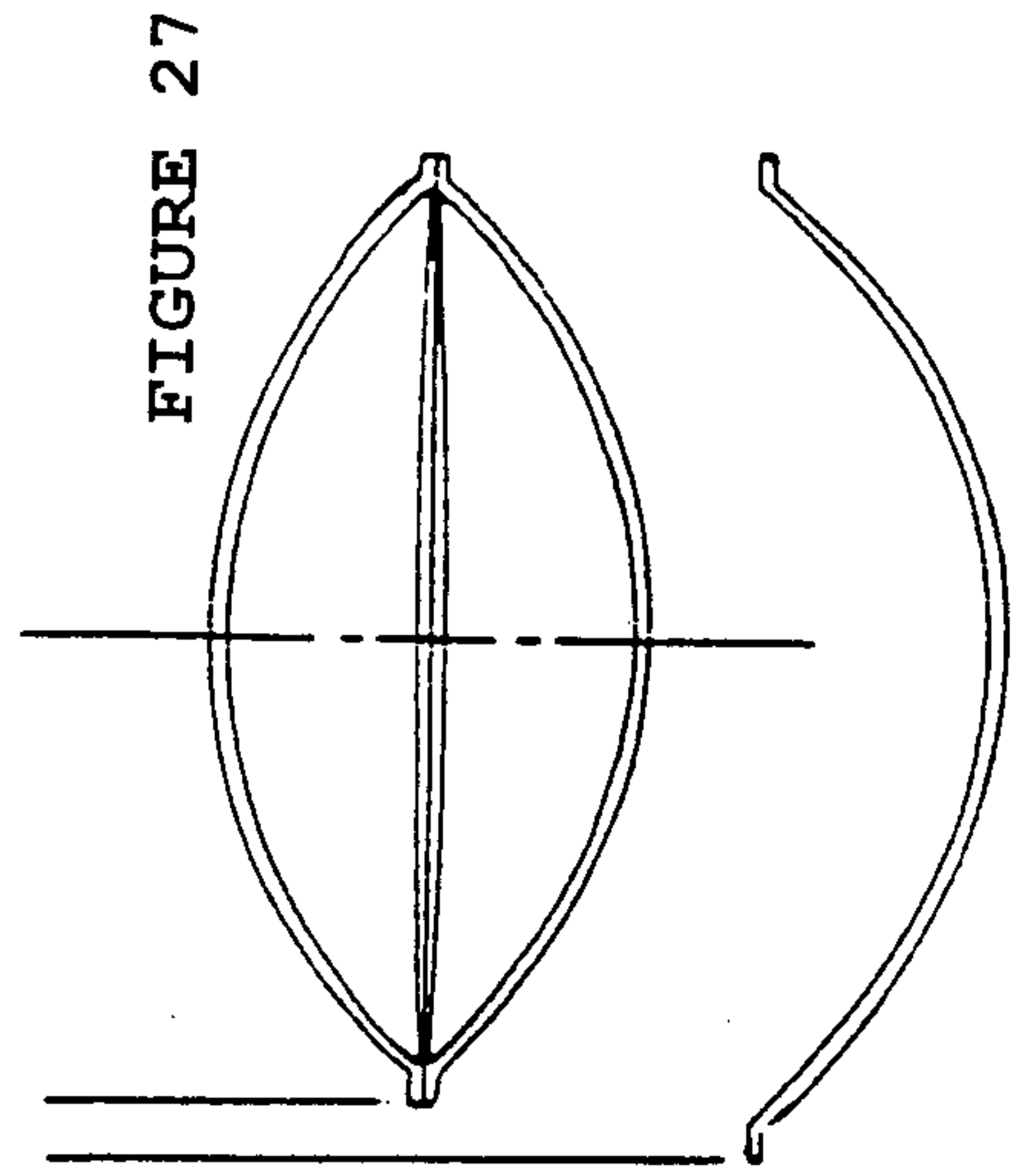

FIGURE 27

FIGURE 28

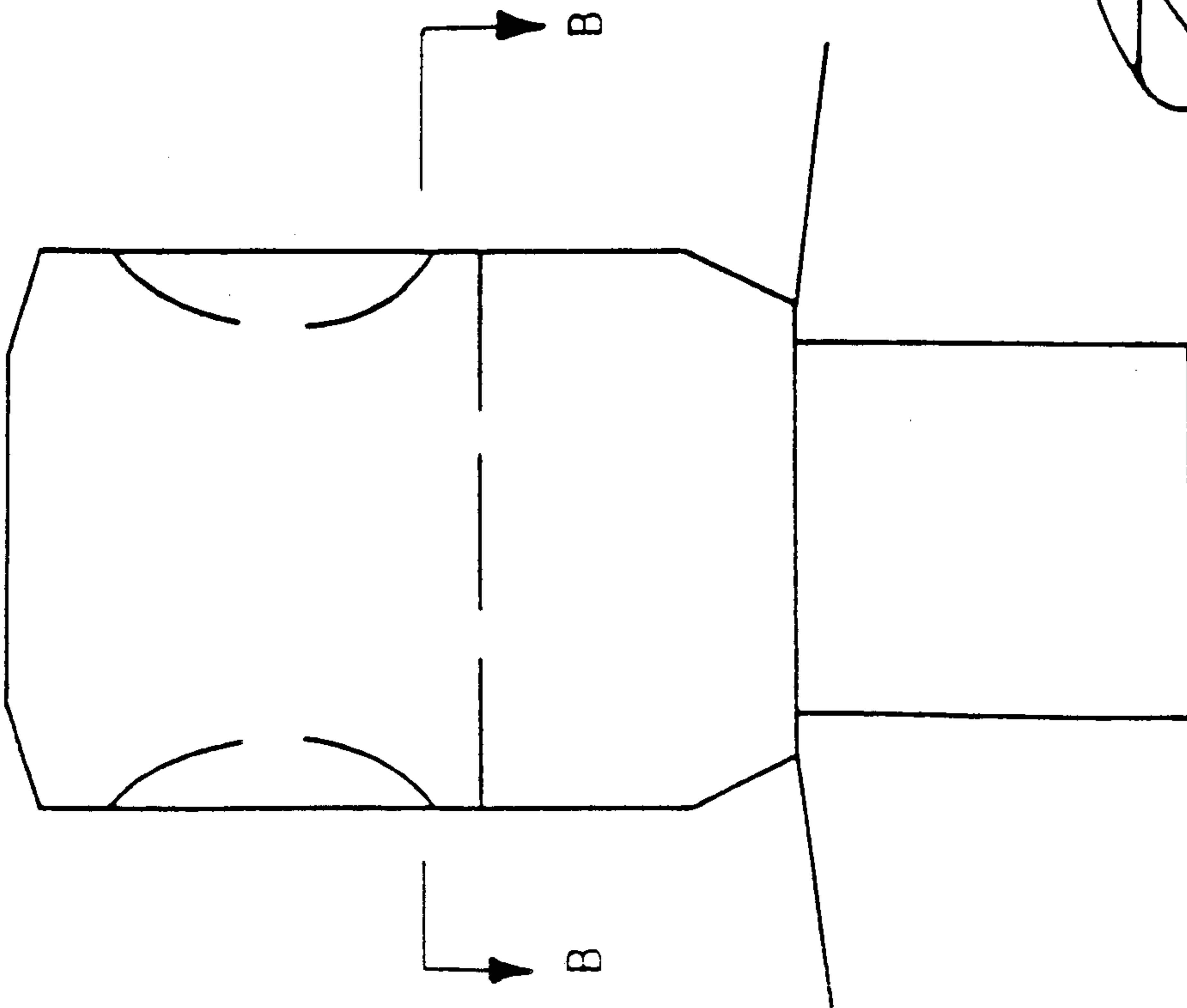

FIGURE 18

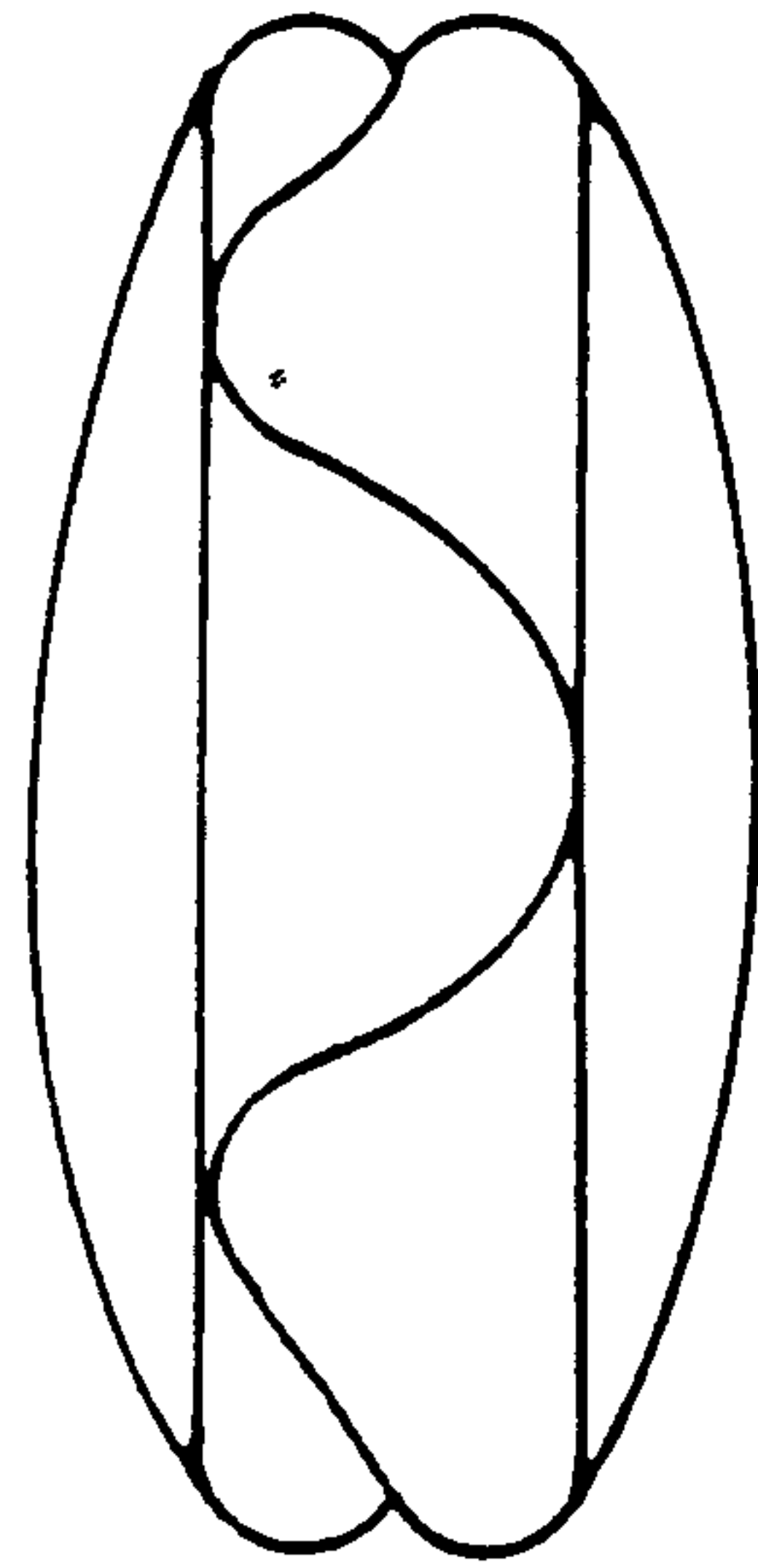

FIGURE 19

12/18

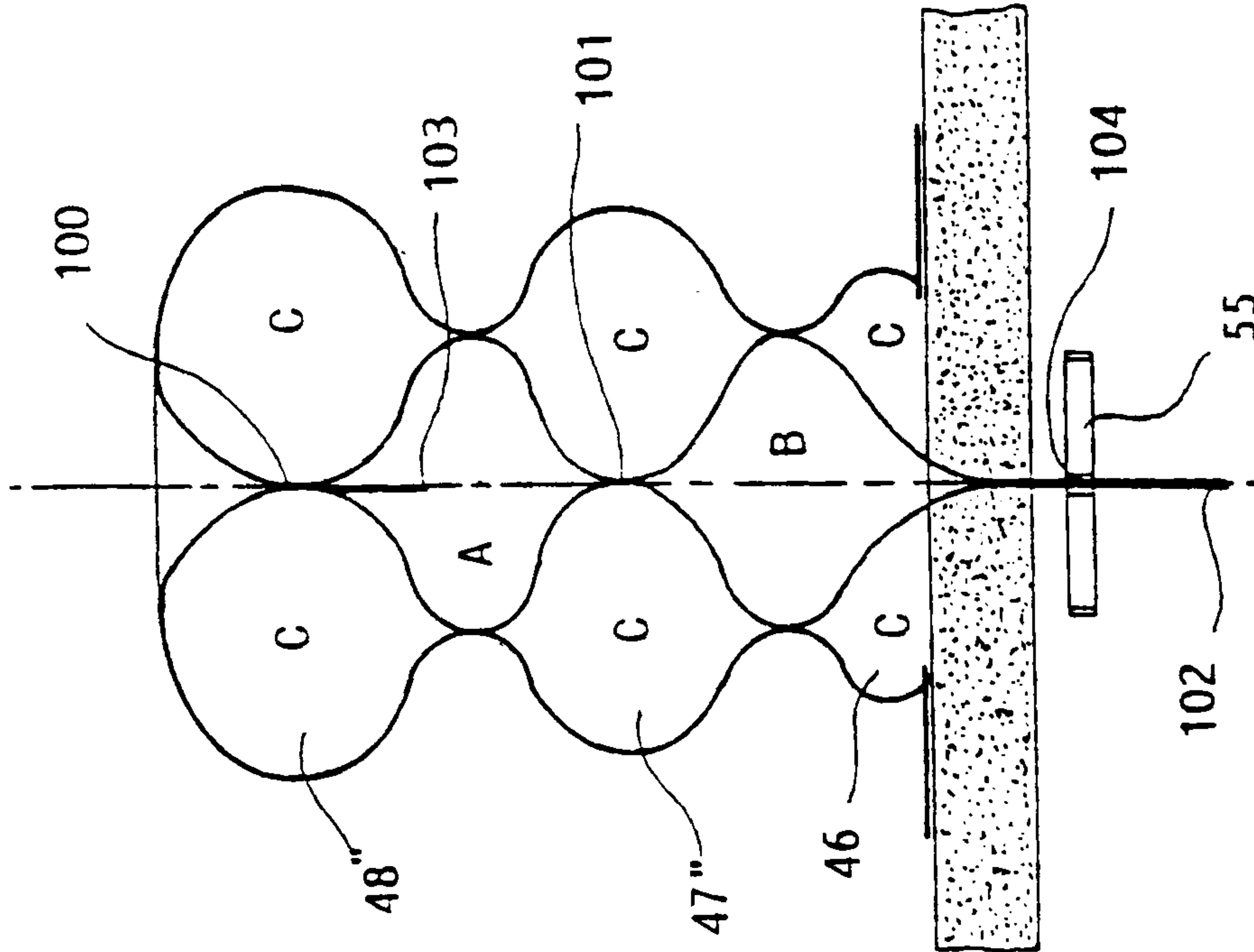

FIGURE 21

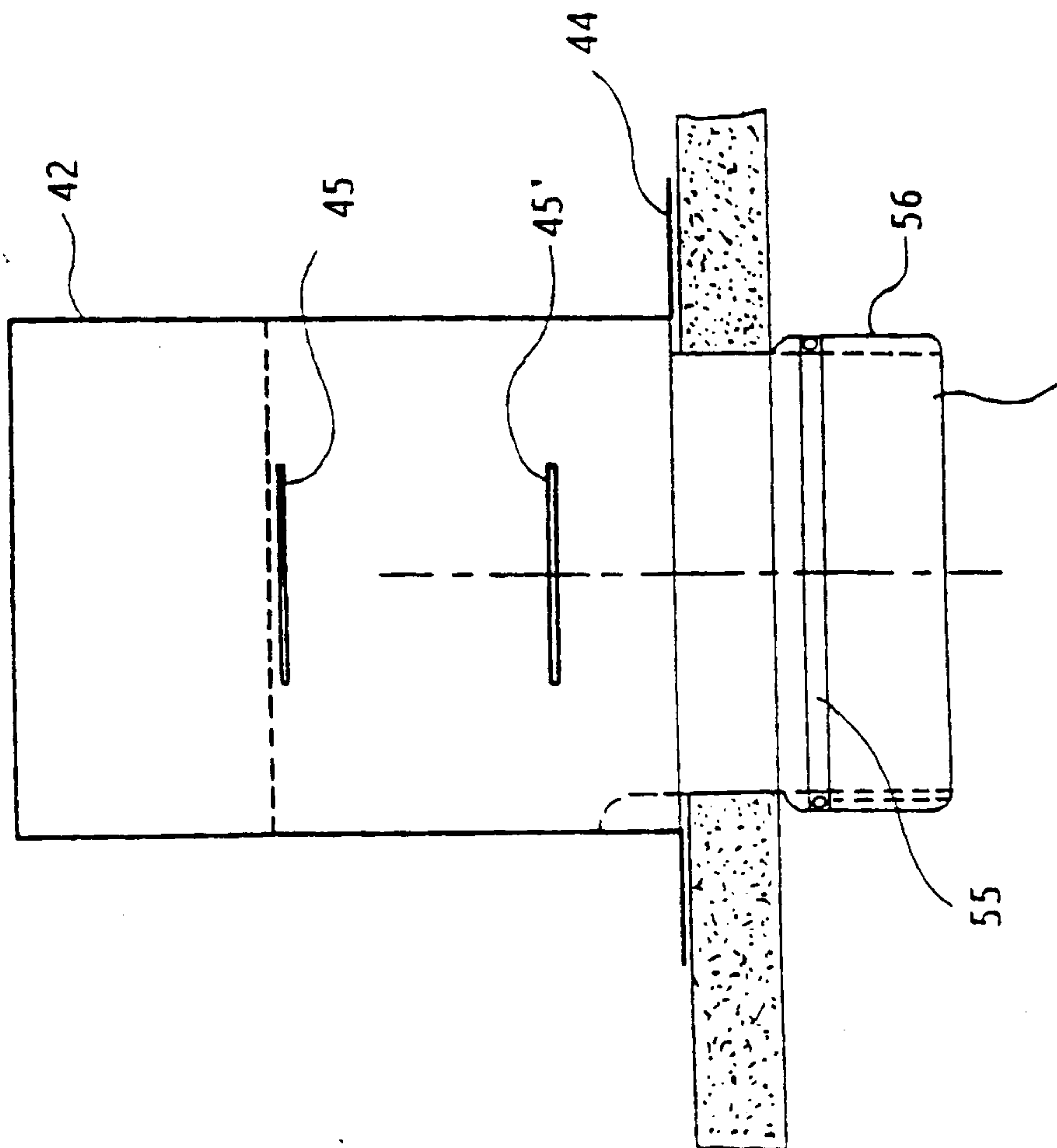

FIGURE 20

13/18

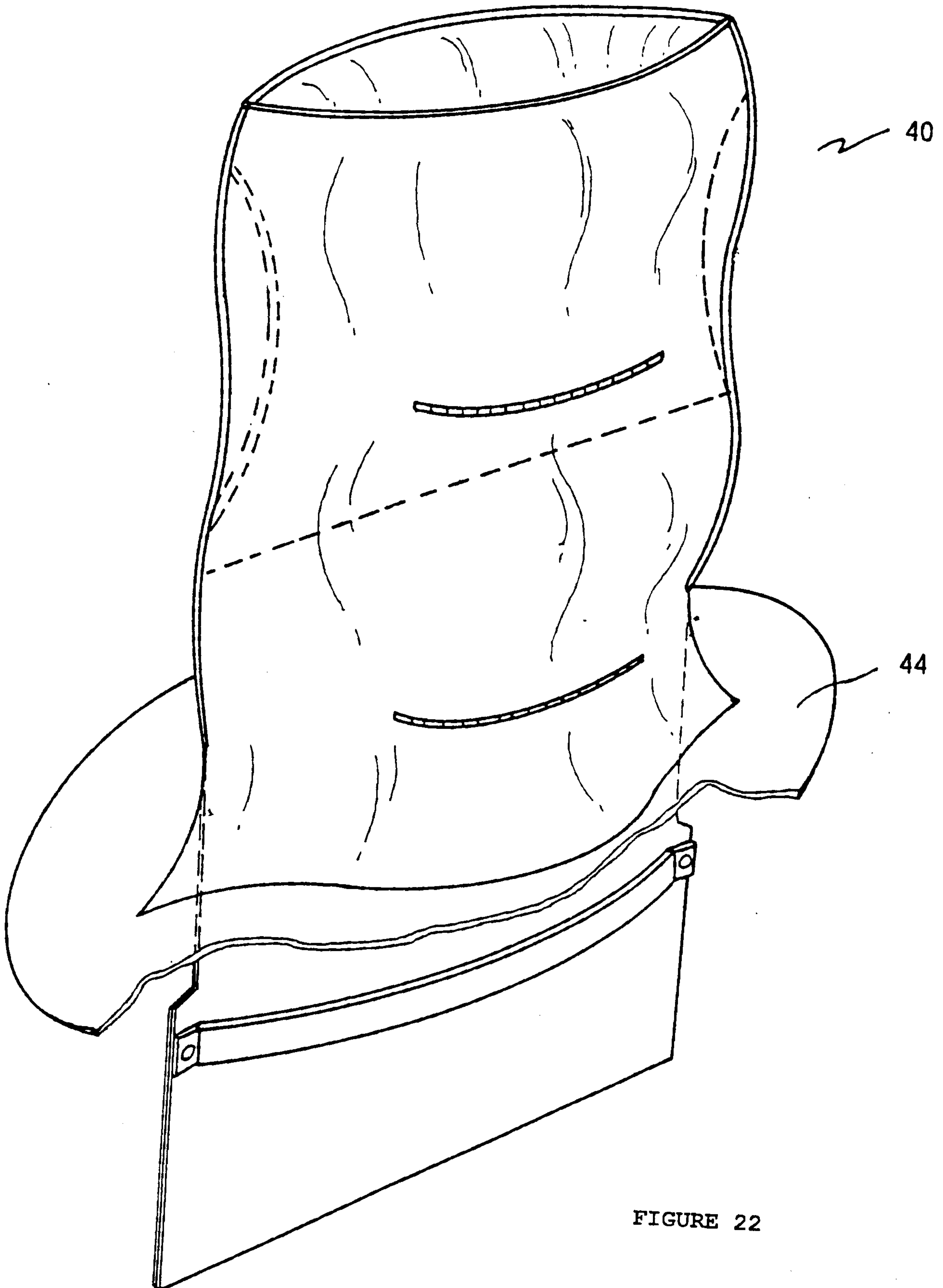

FIGURE 22

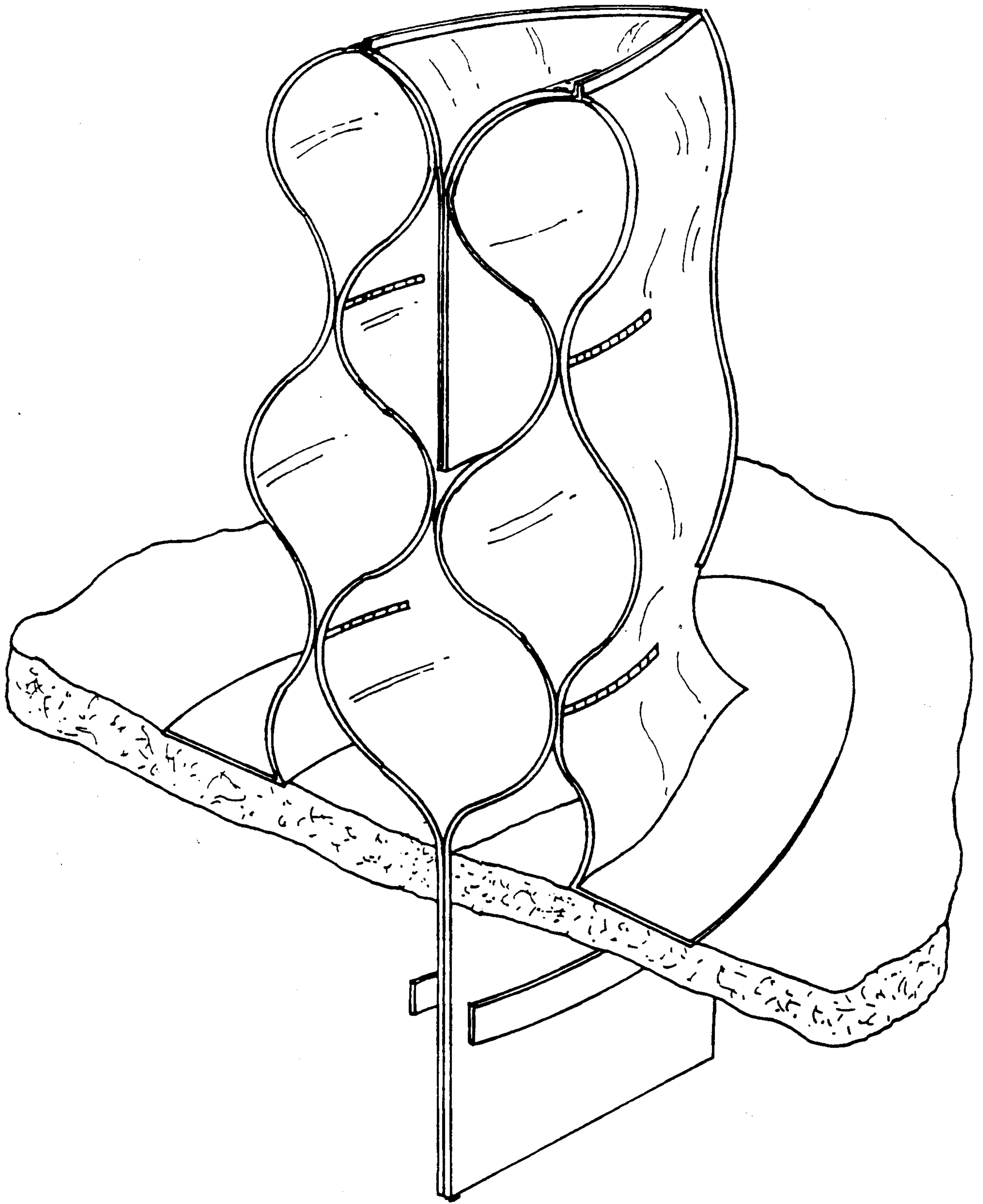

FIGURE 23

15/18

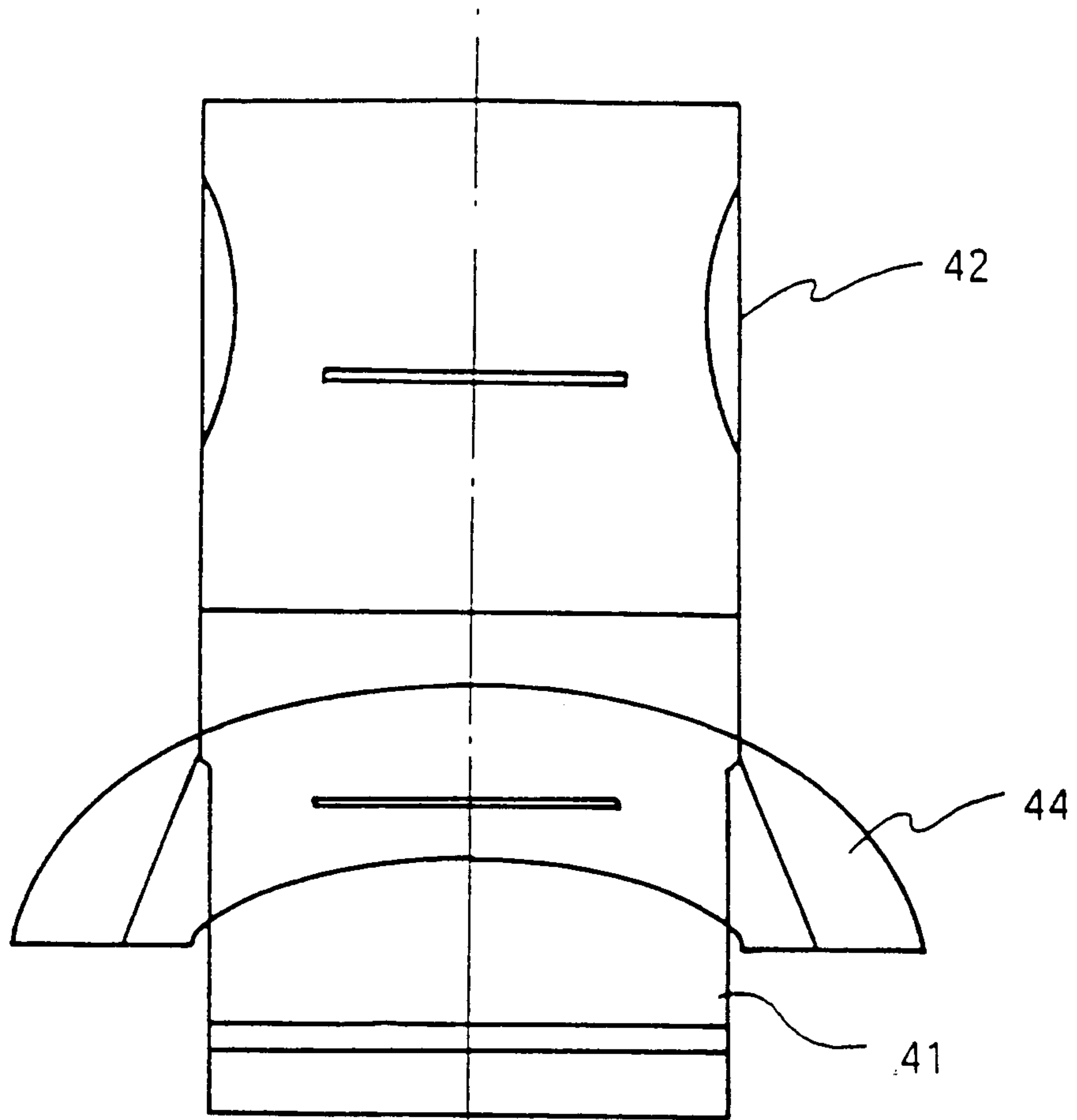

FIGURE 24

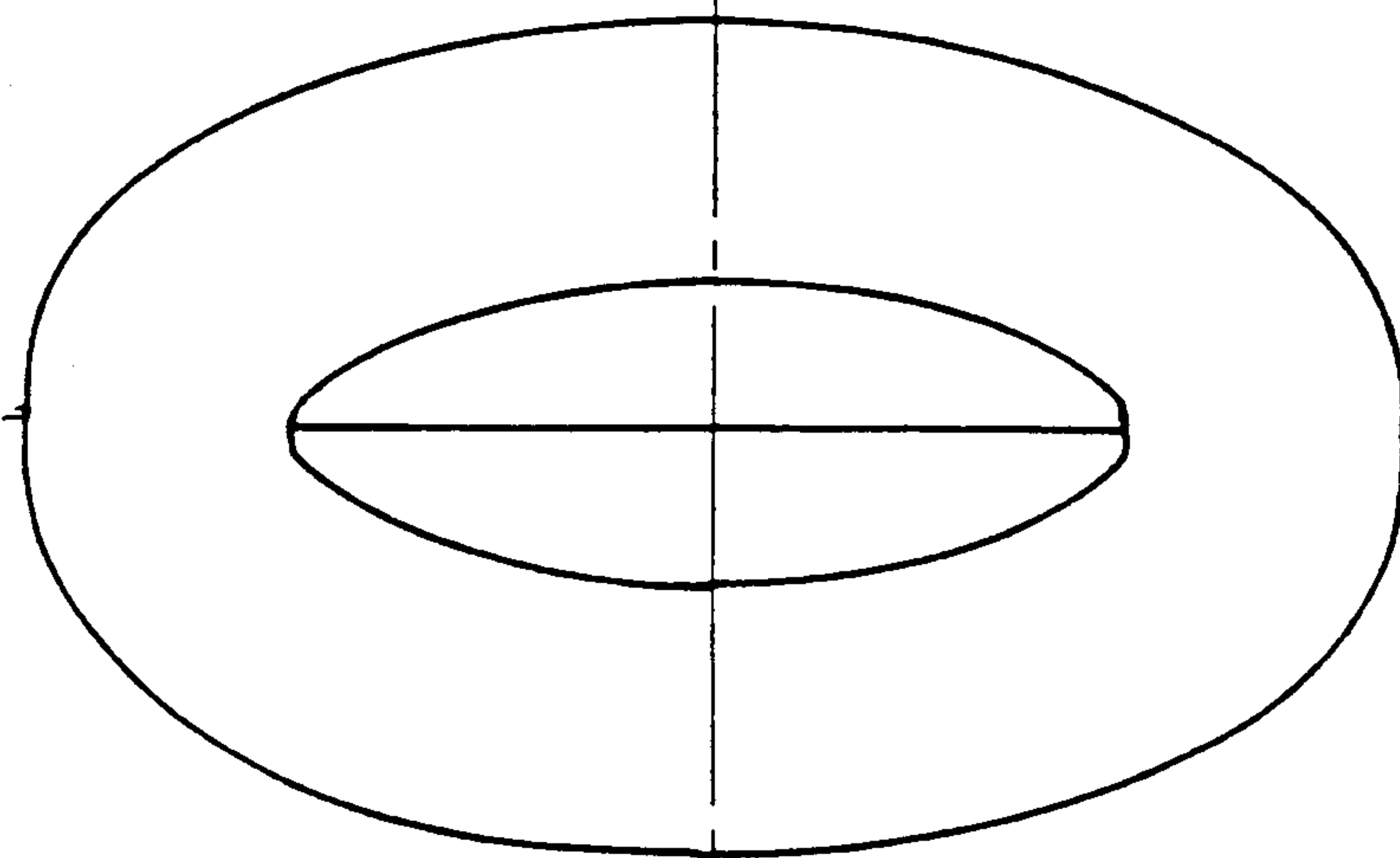

FIGURE 25

16/18

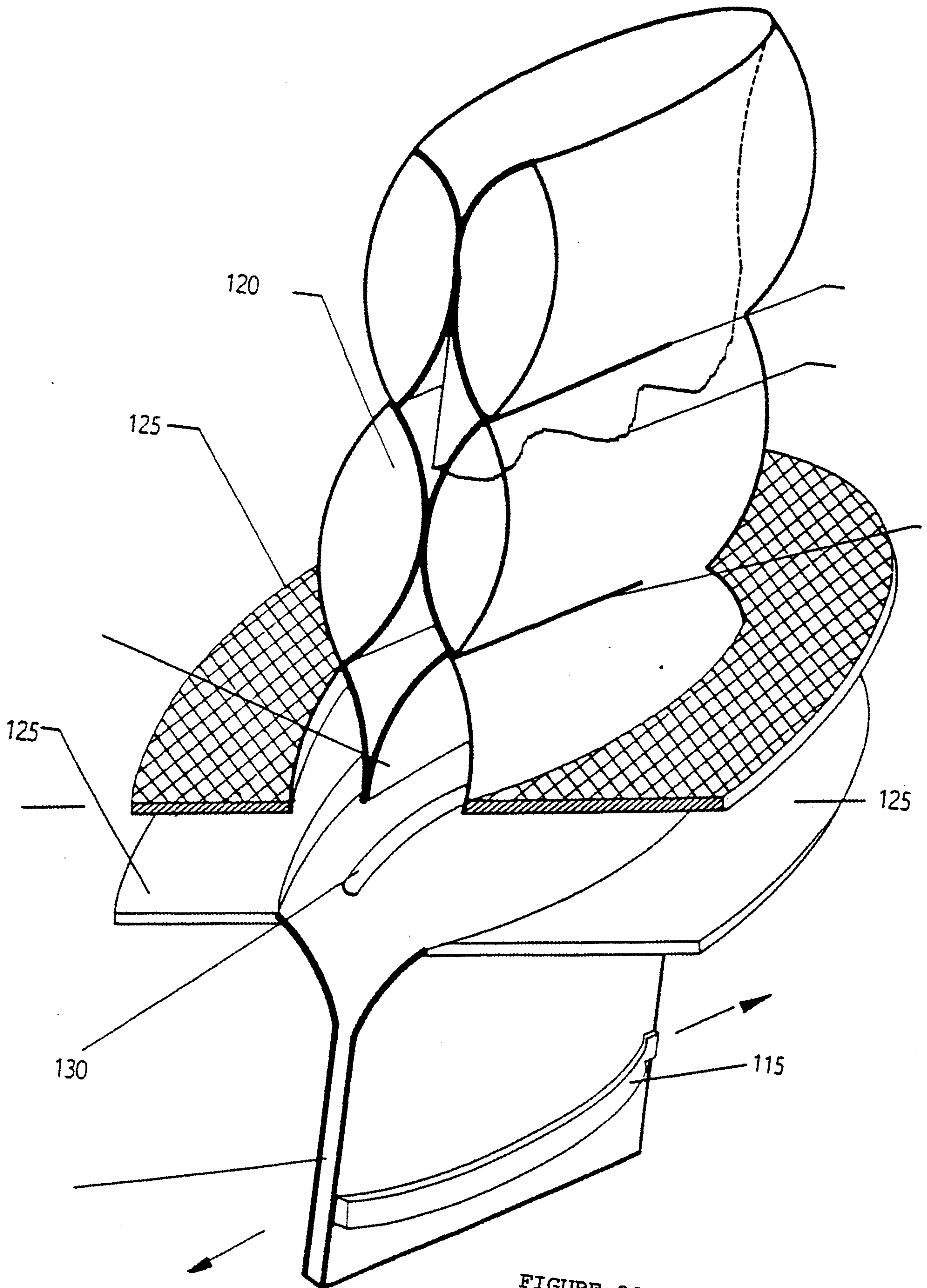

FIGURE 29

17/18

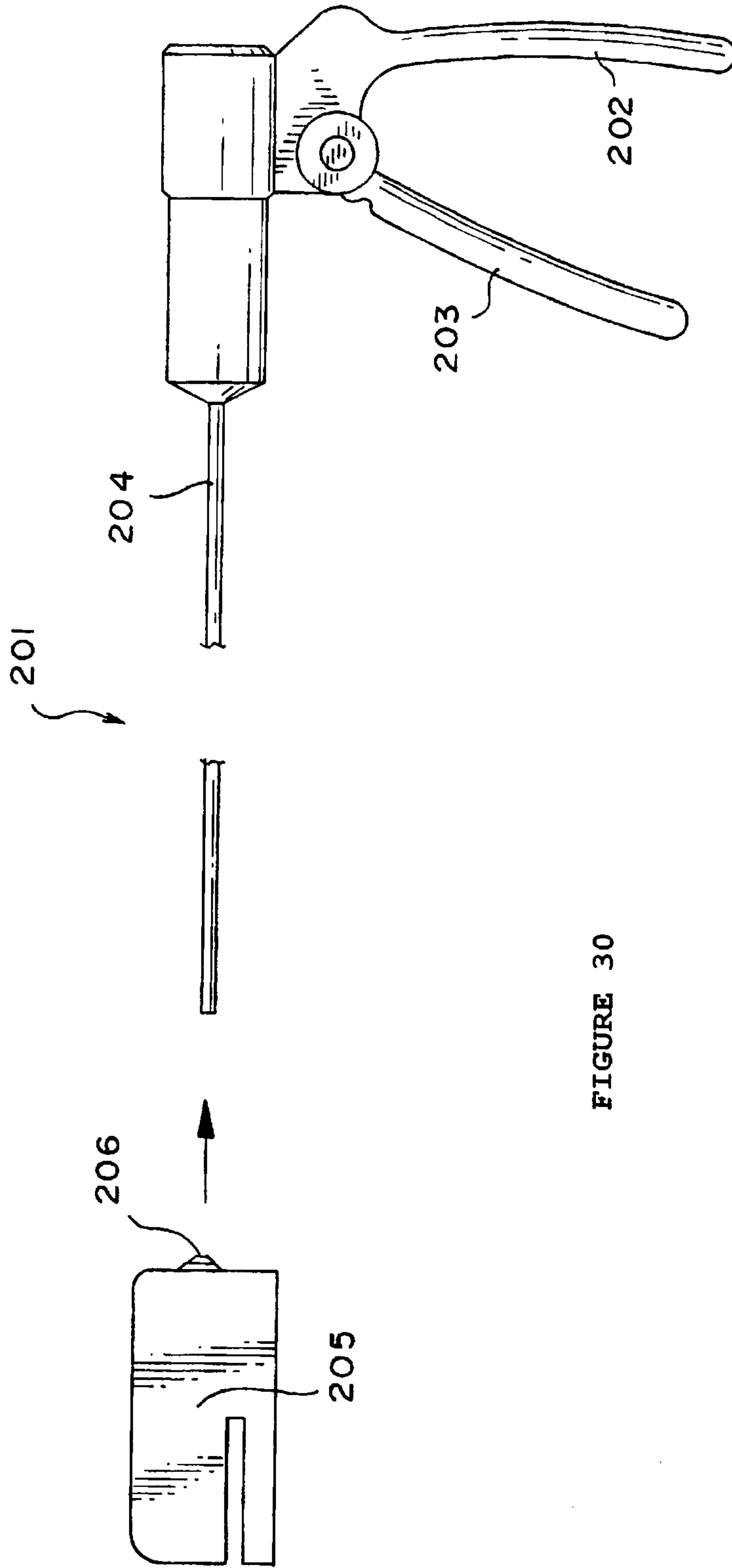

FIGURE 30

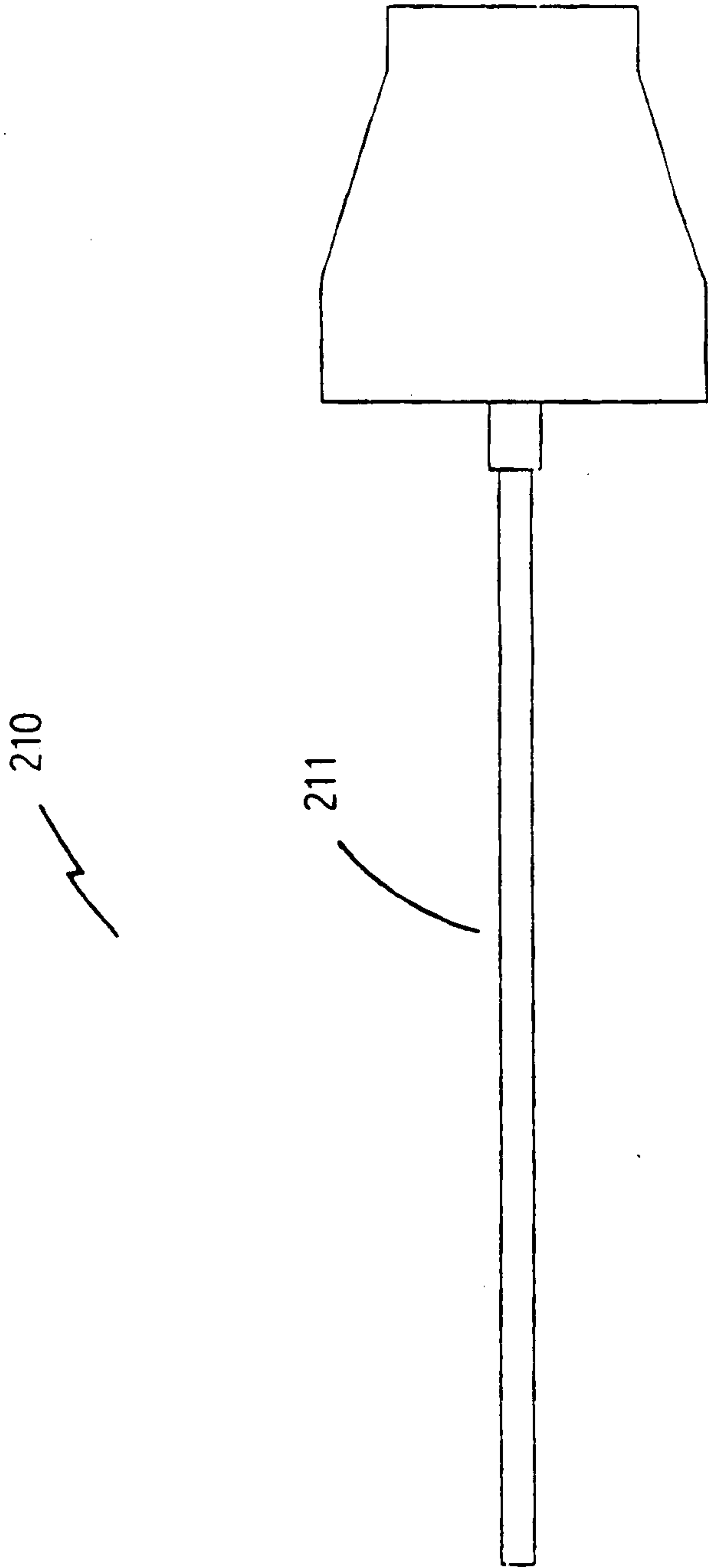

FIGURE 31

