



- (51) International Patent Classification:  
*G06K 9/00* (2006.01)     *H01L 27/14* (2006.01)  
*H01L 23/28* (2006.01)
- (21) International Application Number:  
PCT/US2014/048049
- (22) International Filing Date:  
24 July 2014 (24.07.2014)
- (25) Filing Language: English
- (26) Publication Language: English
- (30) Priority Data:  
61/858,017     24 July 2013 (24.07.2013)     US  
61/858,067     24 July 2013 (24.07.2013)     US  
14/339,656     24 July 2014 (24.07.2014)     US
- (71) Applicant: SYNAPTICS INCORPORATED [US/US];  
1251 McKay Drive, San Jose, CA 951131 (US).
- (72) Inventors: WICKBOLDT, Paul; 1251 Mckay Dr, San Jose, CA 95131 (US). DEAN, Gregory, Lewis; 1251 McKay Dr, San Jose, CA 95131 (US). THOMPSON, Erik, Jonathon; 1251 McKay Dr, San Jose, CA 95131 (US). MOLESA, Steven; 1251 McKay Dr, San Jose, CA 95131 (US). JANDU, Jaswinder; 1251 McKay Dr, San Jose, CA 95131 (US). SMITH, Patrick; 1251 McKay Dr, San Jose, CA 95131 (US).

- (74) Agents: O'Regan, Cecily Ann et al.; Shartsis Friese LLP, One Maritme Plaza - 18th Floor, San Francisco, CA 94111 (US).
- (81) Designated States (unless otherwise indicated, for every kind of national protection available): AE, AG, AL, AM, AO, AT, AU, AZ, BA, BB, BG, BH, BN, BR, BW, BY, BZ, CA, CH, CL, CN, CO, CR, CU, CZ, DE, DK, DM, DO, DZ, EC, EE, EG, ES, FI, GB, GD, GE, GH, GM, GT, HN, HR, HU, ID, IL, IN, IR, IS, JP, KE, KG, KN, KP, KR, KZ, LA, LC, LK, LR, LS, LT, LU, LY, MA, MD, ME, MG, MK, MN, MW, MX, MY, MZ, NA, NG, NI, NO, NZ, OM, PA, PE, PG, PH, PL, PT, QA, RO, RS, RU, RW, SA, SC, SD, SE, SG, SK, SL, SM, ST, SV, SY, TH, TJ, TM, TN, TR, TT, TZ, UA, UG, US, UZ, VC, VN, ZA, ZM, ZW.
- (84) Designated States (unless otherwise indicated, for every kind of regional protection available): ARIPO (BW, GH, GM, KE, LR, LS, MW, MZ, NA, RW, SD, SL, SZ, TZ, UG, ZM, ZW), Eurasian (AM, AZ, BY, KG, KZ, RU, TJ, TM), European (AL, AT, BE, BG, CH, CY, CZ, DE, DK, EE, ES, FI, FR, GB, GR, HR, HU, IE, IS, IT, LT, LU, LV, MC, MK, MT, NL, NO, PL, PT, RO, RS, SE, SI, SK, SM, TR), OAPI (BF, BJ, CF, CG, CI, CM, GA, GN, GQ, GW, KM, ML, MR, NE, SN, TD, TG).

[Continued on next page]

(54) Title: SIGNAL STRENGTH ENHANCEMENT IN A BIOMETRIC SENSOR ARRAY

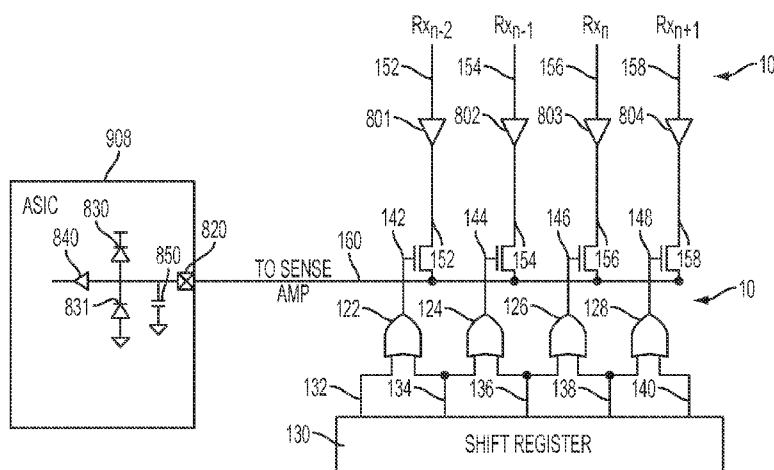

FIG. 2B

(57) Abstract: A biometric imager may comprise a plurality of sensor element traces formed in or on a sensor substrate which may comprise at least a portion of a display screen defining a biometric sensing area and forming in-active pixel locations; an auxiliary active circuit formed in or on the sensor substrate on the periphery of the biometric sensing area and in direct or indirect electrical contact with the sensor element traces; and providing a signal processing interface to a remotely located controller integrated circuit. The sensor element traces may form a portion of one dimensional linear sensor array or pixel locations in a two dimensional grid array capacitive gap biometric imaging sensor. The auxiliary circuit may provide pixel location selection or pixel signal amplification. The auxiliary circuit may be mounted on a surface of the display screen. The auxiliary circuit further comprising a separate pixel location selection controller circuit.

WO 2015/013530 A1

**Published:**

— *with international search report (Art. 21(3))*

**SIGNAL STRENGTH ENHANCEMENT IN A BIOMETRIC SENSOR ARRAY****CROSS-REFERENCE**

[0001] This application claims priority to U.S. Patent Application **14/339,656** filed July 24, 2014, which claims the benefit of U.S. Provisional Application Nos. **61/858,017**, filed July 24, 2014, entitled SIGNAL STRENGTH ENHANCEMENT IN A BIOMETRIC SENSOR ARRAY, and **61/858,067**, filed July 24, 2013, entitled BIOMETRIC SENSOR ON GLASS PACKAGINGS AND HOUSINGS AND METHODS THEREFOR, which applications are incorporated herein by reference.

[0002] The present application is related to pending U.S. Patent Applications Serial No. 12/914,812, filed on October 28, 2010, entitled INTEGRATED FINGERPRINT SENSOR AND DISPLAY, Pub. No. **US 2011/0102567 A1**, published on May 5, 2011; Ser. No. 12/916,000, filed on October 29, 2010, entitled SYSTEMS AND METHODS FOR SENSING FINGER PRINTS THROUGH A DISPLAY, Pub. No. **US 2011/0102569 A1**, published on May 5, 2011; Ser. No. 13/099,983, filed on May 3, 2011, entitled FINGERPRINT SENSOR AND INTEGRATABLE ELECTRONIC DISPLAY, Pub. No. **US 2011/0267298 A1**, published on November 3, 2011; Pub. No. **US 2012/0242635 A1** published September 27, 2012, entitled FINGERPRINT SENSOR AND INTEGRATABLE ELECTRONIC DISPLAY, Pub. No. **US 2012/0242635 A1**, published on September 27, 2012; Pub. No. **US 2013/0169590 A1**, published July 4, 2013, entitled STRUCTURES AND MANUFACTURING METHODS FOR GLASS COVERED ELECTRODE DEVICES, Pub. No. **US 2013/0169590 A1**, published on July 4, 2013; Pub No. **US 2013/0265137 A1**, published October 10, 2013, entitled INTEGRATABLE FINGERPRINT SENSOR PACKAGINGS; Pub. Bo **US 2014/0103943 A1**, published April 17, 2014, entitled FINGERPRINT SENSOR AND BUTTON COMBINATIONS AND METHODS OF MAKING SAME, the disclosures of each of which are hereby incorporated by reference.

**BACKGROUND**

[0003] Biometric authentication systems are used for authenticating users. Biometric sensing technology provides a reliable, non-intrusive way to verify individual identity for authentication purposes.

**[0004]** Fingerprints, like various other biometric characteristics, are based on unalterable personal characteristics and thus are a reliable mechanism to identify individuals. There are many potential applications for utilization of biometric and fingerprints sensors. For example, electronic fingerprint sensors may be used to provide access control in stationary applications, such as security checkpoints. Electronic fingerprint sensors may also be used to provide access control in portable applications, such as portable computers, personal data assistants (PDAs), cell phones, gaming devices, navigation devices, information appliances, data storage devices, and the like. Accordingly, some applications, particularly portable applications, may require electronic fingerprint sensing systems that are compact, highly reliable, and inexpensive.

**[0005]** Various electronic fingerprint sensing methods, techniques, and devices have been proposed and/or are currently in use or under development. For example, optical and capacitive fingerprint sensing devices are currently on the market. Like a digital camera, optical technology utilizes visible light to capture a digital image. In particular, optical technology may use a light source to illuminate an individual's finger while a sensor, e.g., a charge-coupled device ("CCD") captures an analog image. This analog image may then be converted to a digital image. Other sensors may be pressure based, e.g., using piezoelectric materials or deformable capacitive sensors, impedance based, such as resistive sensors, heat based, etc.

**[0006]** There are generally two types of capacitive fingerprint sensing technologies: passive and active. Both types of capacitive technologies can utilize similar principles of capacitance changes to generate fingerprint images. Passive capacitive technology typically utilizes a linear one-dimensional (1D) or a two-dimensional (2D) array of plates (i.e., electrodes or traces) to apply an electrical signal, e.g., in the form of an electrical field, such as a varying high speed (radio frequency ("RF") or the like) signal transmitted to the finger of the user from a transmitter trace and received at a receiver trace after passage through the finger. A variation in the signal caused by the impedance of the finger indicates, e.g., whether there is a fingerprint valley or ridge between the transmitter trace and the receiver trace in the vicinity of where the transmission and reception between the traces occurs. Fingerprint ridges, as an example, can typically display far less impedance (lower capacitance across the gap) than valleys, which may exhibit relatively high impedance (higher capacitance across

the gap). The gaps can be between traces on the same plane, horizontal, or in different planes, vertical.

[0007] Active capacitive technology is similar to passive technology, but may require initial excitation of the epidermal skin layer of the finger by applying a current or a voltage directly to the finger. Typically, thereafter, the actual change in capacitance between the source of the voltage or current on an excitation electrode (trace) and another receptor electrode (trace) is measured to determine the presence of a valley or ridge intermediate the source electrode and the another receptor electrode. Active capacitive sensors, however, may be adversely affected by such effects as dry or worn finger print components. By contrast, passive sensors are typically capable of producing images regardless of contact resistance and require significantly less power, e.g., because of more penetration of the layer of skin of the user in the vicinity of the transmitter/receiver pair.

[0008] In some embodiments the traces may form a plurality of transmitter electrodes and a single receiver electrode or a plurality of receiver electrodes and a single transmitter electrode arranged in a linear one dimensional capacitive gap array. In such embodiments the capacitive gape may be horizontal across the gap formed by the respective ends of the plurality of traces and the single trace, whether transmitter or receiver. Advantageously such sensor systems can be very compact, inexpensive to manufacture, with the sensor element traces simply formed on a substrate, such as a flexible substrate, made of, e.g., Kapton® tape made by 3M, and reliable, e.g., due to insulation of the finger of the user from the traces and/or electric contact, etc.

[0009] In some embodiments, the traces may form a 2D grid array, e.g., with rows of transmitter/receiver traces on one substrate and columns of receiver/transmitter traces on the same or a separate substrate, e.g., laminated together with some form of dielectric between the traces to form a 2D sensor element array. Such 2D arrays may be essentially as long as the last digit of the finger forming a placement sensor element array, or shorter in the direction of the length of the finger, forming a swiped 2D array. While both the 1D linear array sensors systems and the 2D array sensor systems can operate in essentially the same way, i.e., with transmission of a signal from a transmitter trace to a receiver trace, the 2D arrays are larger in the region that must be exposed in the vicinity of the finger being sensed, and are generally more complex electronically. In addition such 2D arrays can involve higher degrees of noise and other impediments to accurate signal processing of the received signals and

also more complicated software and hardware for reconstructing the fingerprint from a series of swiped 2D images accumulated during sensing in the direction of the finger and sensor elements relative movement during the swipe.

[0010] Although each of the fingerprint sensing technologies described above may generate satisfactory fingerprint images, each may be adversely affected by noise, interference, and other effects. For example, capacitive sensors may be particularly susceptible to noise and parasitic capacitive coupling, which may degrade the quality of the acquired fingerprint image. 2D arrays may be more so susceptible than linear 1D arrays. Prior attempts to reduce noise in 2D sensors have employed reference capacitors positioned at each sensor pixel to provide a method of subtracting noise contributions that affect both the finger capacitance and the reference capacitor. This technique is most effective for electrical noise at the pixel level, as seen, e.g., in U.S. Patents Nos. **8,115,497 B2**, PIXEL SENSING CIRCUIT WITH COMMON MODE CANCELLATION, issued on February 14, 2012, to Gozzini, and/or US Pub. No. **US 2012/0085822 A1**, entitled FINGER SENSING DEVICE INCLUDING DIFFERENTIAL MEASUREMENT CIRCUITRY AND RELATED METHODS, published on April 12, 2012, referenced above. Also proposed has been the user of a reference electrode external to the sensor array, e.g., that is not affected by an actual presence of the finger of a user, such as is discussed in United States Patent No. **8,421,890 B2**, entitled ELECTRONIC IMAGER USING AN IMPEDANCE SENSOR GRID ARRAY AND METHOD OF MAKING, issued to Benkley on April 16, 2013. Accordingly, it would be an advance in the art to reduce the effects of noise, parasitic capacitive coupling, and other effects in capacitive-type fingerprint sensing circuits.

[0011] Two-dimensional matrix format fingerprint readers have historically been built with row and column multiplexing circuits along the edge of the sensor pixel array, e.g., as illustrated in U.S. Patent No. **7,616,786 B2**, entitled FINGER BIOMETRIC SENSOR WITH SENSOR ELECTRONICS DISTRIBUTED OVER THIN FILM AND MONOCRYSTALLINE SUBSTRATES AND RELATED METHODS, issued to Setlak, et al., on November 10, 2009; U.S. Patent No. **7,835,553 B2**, entitled IDENTITY AUTHENTICATION DEVICE AND FINGERPRINT SENSOR, issued to Miyasaka on November 16, 2010 and U.S. Patent No. **7,755,369 B2**, issued to Chuang, et al. March 23, 2010, entitled CAPACITIVE FINGERPRINT SENSOR AND THE PANEL THEREOF. This is true of both silicon substrate and glass

substrate fingerprint readers. The use of such row and column multiplexing circuits all the signals to and from the individual rows and columns to be carried over a small number of signal lines. This has been done within a controller IC, but this makes the controller IC more expensive both from the standpoint of circuitry included in the IC and thus chip real estate utilized, as well as input/output connections required in the chip packaging.

**[0012]** According to co-pending U.S. Patent Pub US 2013/0177220 A1, entitled METHODS AND DEVICES FOR CAPACITIVE IMAGE SENSING, published July 11, 2013, noise reduction in a 1D sensor array can be accomplished by subtracting an NI (background) signal from the primary finger influenced (“FI”) signal as a means of subtracting out noise signals, e.g., that affect adjacent receiver lines in a linear sensor.

**[0013]** The emergence of portable electronic computing platforms allows functions and services to be enjoyed wherever necessary. Palmtop computers, personal digital assistants (“PDAs”), mobile telephones, portable game consoles, biometric/health monitors, and digital cameras are some everyday examples of portable electronic computing platforms. The desire for portability has driven these computing platforms to become smaller. Such portable electronic computing platforms, as well as some larger ones like lap top computer, pads and pods, electronic tablets and the like have been increasingly shown to be in need of authentication of the user to access the device or once on the device to access applications running on the device and/or to access remote applications such as websites, web-pages, user accounts, such as email of social network accounts, and engage in various forms of on-line transactions, each requiring varying degrees of authentication of the user to the device/application and the application to the user. Such processes have increasingly required input from the user of user information, e.g., in the form of user name and password/PIN, but even more so more sophisticated and secure forms of user authentication to the relying party and vice versa. For this purpose various forms of biometric user identification input, e.g., fingerprint authentication information is being required.

**[0014]** It is difficult to efficiently collect user authentication input information, e.g., fingerprint images or fingerprint authentication determinations and the like on these ever-smaller personal computing and communication devices. In addition, such as portable electronic computing platforms need other forms of user inputs for multiple purposes including, but not limited to, navigation: moving a cursor or a pointer to a certain location on a display; selection: choosing, or not choosing, an item or an

action; and orientation: changing direction with or without visual feedback. Where the usual form of a GUI input device, e.g., an actual or virtual mouse may easily be used with and transported with a lap top computer or larger touch screen device, such as a tablet, smaller devices with concomitantly smaller display areas, such as cell phones, pads and pods, Blackberrys, etc. can be perfect candidates for sensors, such as biometric sensors and/or buttons and/or combinations thereof that can perform authentication as well as act as GUI input devices.

**[0015]** Prior art systems have borrowed concepts for user input from much larger personal computers. Micro joysticks, navigation bars, scroll wheels, touch pads, steering wheels and buttons have all been adopted, with limited success, in today's portable electronic computing platforms. All of these devices consume substantial amounts of valuable surface real estate on a portable device. Mechanical devices such as joysticks, navigation bars and scroll wheels can wear out and become unreliable. Because they are generally physically designed for a single task, they typically do not provide functions of other navigation devices. Their sizes and required movement on or within the device often precludes optimal ergonomic placement on portable computing platforms. Moreover, these smaller versions of their popular personal computer counterparts usually do not offer accurate or high-resolution position information, since the movement information they sense is too coarsely grained.

**[0016]** Most commercially available biometric image sensors, such as fingerprint image sensors that detect and measure features (e.g., valleys, ridges, and minutiae) on the surface of a finger using capacitive, thermal, optical, or other sensing technologies as noted above, fall into the two above noted categories: (1) full-size placement sensors and (2) typically smaller so-called swipe sensors, with the latter being either 1D or 2D. Placement sensors have an active sensing surface that is large enough to accommodate most of the interesting part of a finger at the same time. Generally, they are rectangular in shape with a sensing surface area of at least 100 mm<sup>2</sup>. The finger is held stationary while being imaged on the full-placement sensor.

**[0017]** The other type of finger image sensor, called a swipe sensor, is characterized by a strip-like imaging area that is fully sized in one direction (typically in length) but abbreviated in the other (typically width). An example is the Atrua Wings ATW100 sensor, as described by Andrade in US Patent Application **US 2003/0016849 A1** published January 23, 2003 (issued as **US 7,256,589 B2** on August 14, 2007), and PCT publication **WO 02/095349**. A finger is swiped across the sensor until all parts

of it are imaged, analogous to how a feed through paper document scanner operates. A sequence of slices or frames of the finger image is captured and processed to construct a composite image of the finger. As shown in United States Patent No. **7,099,496 B2**, entitled SWIPED APERTURE CAPACITIVE FINGERPRINT SENSING SYSTEMS AND METHODS, issued to Benkley on August 29, 2006 shows a limiting case where the sensed "area" is a single linear 1D array of capacitive gaps.

[0018] Several prior art devices use a touchpad for authenticating a user and moving a cursor on a display device. A touchpad, which operates similarly to a finger image sensor, does not provide enough image resolution or capability to distinguish ridges and valleys on the fingerprint. Instead, the touchpad perceives a finger as a blob and tracks the blob location to determine movement. Therefore, a touchpad cannot follow miniscule movements, nor can it very easily detect rotational movement.

[0019] U.S. Patent Publication No. **US 2002/0054695 A1**, titled "Configurable Multi-Function Touchpad Device," to Bjorn et al. discloses a touchpad that can be configured to authenticate a user or to control a cursor. The touchpad attempts to enhance the function of a touchpad to include fingerprint capability. It merely absorbs the hardware of a capacitive finger image sensor into the much-larger size touchpad to achieve cost-savings. It does not disclose using the finger image data of the data collector for navigation or other device control. Moreover, as conceived, the apparatus of Bjorn, with its large size will preclude the touchpad from being used in most portable electronic computing platforms.

[0020] U.S. Pat. No. **6,408,087 B1**, entitled CAPACITIVE SEMICONDUCTOR USER INPUT DEVICE, issued to Kramer on June 18, 2002 discloses a system that uses a fingerprint sensor to control a cursor on the display screen of a computer. The system controls the position of a pointer on a display according to detected motion of the ridges and pores of the fingerprint. The system has a number of limitations. It uses image-based correlation algorithms and, unlike a system using a swipe sensor, requires fingerprint images with multiple ridges, typical for capacitive placement sensors. To detect a motion parallel to the direction of a ridge, the system requires the sensor to detect pores, a requirement restricting its use to high-resolution sensors of at least 500 dpi. The system detects changes in ridge width to sense changes of finger pressure. However, ridge width measurement requires a very high-resolution sensor to provide low-resolution of changes of finger pressure. The algorithm is unique to

emulating a mouse and is not suitable for emulating other types of input devices, such as a joystick or a steering wheel, where screen movements are not always proportional to finger movements. For example, a joystick requires a returning to home position when there is no input and a steering wheel requires rotational movement. The system is unique to capacitive sensors where inverted amplifiers are associated with every sensor cell.

**[0021]** Capacitive fingerprint sensor arrays are often required to sense very small signals (e.g. associated with passive modification of a transmitted signal due to femtofarad differences in capacitance, e.g., between a transmitter electrode (trace) and a receiver electrode (trace) due to the difference between the electric field passing from the transmitter to the receiver through a finger of a user passing through a ridge or a valley of the fingerprint of the user. This can be especially so when attempting to read a fingerprint through a somewhat thick cover layer (0.100 mm or more, for example) of glass or other dielectric material. In one-dimensional fingerprint sensors which use a linear array of transmitters and a single receiver electrode, it has been suggested that the signal strength on the receiver line can be boosted by activating multiple transmitters simultaneously transmitting to the single receiver or multiple receivers receiving from the single transmitter trace, e.g., as discussed in co-pending US Patent Pub. **US 2013/0177220 A1**, entitled METHODS AND DEVICES FOR CAPACITIVE IMAGE SENSING, published July 11, 2013.

**[0022]** Noise reduction methods have been proposed for 2D sensor arrays as well, as exemplified in U.S. Patent Pub. **US 2013/0265137 A1** published October 10, 2013, entitled INTEGRATABLE FINGERPRINT SENSOR PACKAGINGS.

**[0023]** A similar problem(s) can exist for two-dimensional fingerprint sensors as has been suggested for resolution in 1D linear sensor arrays, and the problem may be further complicated by the additional parasitic capacitances resulting from row/column crossovers that are not present in a one-dimensional (linear) sensor array. In order to alleviate this problem, the vast majority of capacitive two-dimensional fingerprint sensors therefore incorporate not only the capacitive sensing electrodes in each sensor pixel, but also amplification circuitry to boost the signal before it travels down the row or column line to a multiplexer or other readout circuit. The signal produced by the presence or absence of a fingerprint ridge can be further boosted by combining the signals from several receiver pixels adjacent to, or surrounding, a

primary transmitter pixel, as is discussed, e.g., in US Pub **US 2012/0085822 A1**, with named inventors Setlak et al., published on April 12, 2012.

**[0024]** Fingerprint readers that are intended to be at least to a large degree transparent are often fabricated on transparent glass. In this case the row and column drive and readout circuits may be contained in a silicon IC that is attached to, i.e., mounted on, the glass. However, the large number of rows and columns and fine pitch of these lines, especially on the silicon IC, requires very high resolution die attach processes and connector pads, or it may also make the silicon IC larger than necessary, to fit all the input & output pads that are necessary. For this reason fingerprint readers built on glass substrates have been built all the necessary row/column multiplexing circuits (often as well as sense amp circuits) in thin film transistor (“TFT”) circuits fabricated directly on the glass, as shown, e.g., in United States Patent Nos. **7,616,786 B2**, entitled **FINGER BIOMETRIC SENSOR WITH SENSOR ELECTRONICS DISTRIBUTED OVER THIN FILM AND MONOCRYSTALLINE SUBSTRATES AND RELATED METHODS**, issued to Setlak on November 10, 2009, where the circuitry for an operation amplifier is split between lower cost TFTs at the sensor array location and higher performance transistors within a remotely mounted control IC; **7,835,553 B2**, entitled **IDENTITY AUTHENTICATION DEVICE AND FINGERPRINT SENSOR**, issued to Miyakasa on November 16, 2010, in which a fingerprint sensor array and local signal processing circuitry is contained in a separate housing separable from a user device and replaceable as a unit; and **7,755,369 B2**, entitled **CAPACITIVE FINGERPRINT SENSOR AND THE PANEL THEREOF**, issued to Chuang et al. on July 13, 2010 in which all of the sensor circuitry, including the controller IC and in-pixel high performance circuitry, such as amplification is formed in or on the glass substrate of a display unit. Such TFT-on-glass fingerprint readers almost always include pixel select and amplification circuitry at each array sensor pixel.

**[0025]** Two-dimensional capacitive fingerprint sensors can be more susceptible to noise and the effects of parasitic capacitances due to their larger size and array structure as compared, e.g., to a one-dimensional (linear array) sensor. For this reason virtually all current two-dimensional fingerprint sensors incorporate in-pixel amplification, and perhaps other signal processing, circuitry. However, this means the sensor array must be made on a silicon wafer or with a technology (such as higher quality TFT technology, that can use, e.g., such high quality and thus more expensive

transistor fabrication technology, e.g., TFT fabrication technology, to provide high quality semiconductor devices such as may be required for such transistors in each pixel. This increases the cost of the sensor substantially compared to a flex or glass based passive sensor matrix, e.g., where the electrodes (traces) forming the sensor elements are printed or etched on a substrate generally in a single layer process, more like printed circuit board (“PCB”) fabrication process.

#### **SUMMARY OF THE DISCLOSED SUBJECT MATTER**

[0026] An aspect of the disclosure is directed to a method of imaging a biometric object. Suitable methods comprise: utilizing a biometric image sensor, comprising: a plurality of capacitive gap sensor electrode traces forming an array of biometric sensor imaging pixel locations within a biometric sensing area of the biometric image sensor, at least one of which sensor electrode traces forming a drive signal transmitter electrode trace and at least one of which sensor electrode traces forming a drive signal receiver electrode trace, wherein a change in a drive signal transmitted by a respective at least one drive signal transmitter electrode trace and received by a respective at least one drive signal receiver electrode trace is indicative of a biometric image characteristic at the respective pixel location in the array, the respective drive signal transmitter electrode trace and respective drive signal receiver electrode trace being formed on one of a single side of a first substrate and on opposite sides of the first substrate; utilizing a controller contained in an integrated circuit mounted to a second substrate remote from the biometric sensing area and in electrical contact with the sensor electrode traces; utilizing an intermediate logic circuit intermediate, or formed between, the controller and the sensor electrode traces in the biometric sensing area, which intermediate logic circuit is at least one of formed on the first substrate and formed on a third substrate mounted on the first substrate, to control an activation sequence for a subset of the plurality of the capacitive gap sensor array pixel locations in response to a single signal from the controller to the intermediate logic circuit. Additionally, a change in a resulting signal received by the at least one resulting signal receiver electrode trace is indicative of a biometric image characteristic at a respective pixel location in the array. At least one of the sensor electrode traces can be configured to form a drive signal transmitter electrode and at least one of the sensor electrode traces forming a resulting signal receiver electrode trace, the respective drive signal transmitter electrode and respective resulting signal receiver electrode trace being formed on one of a single side of a first substrate and an opposite side of

the first substrate. Additionally, the first substrate and the second substrate can comprise a single substrate. In some configurations, the single substrate can comprise one of a flexible dielectric and a glass substrate. In still other configurations, the single signal from the controller can comprise a first coded control signal causing the intermediate logic circuit to one of (1) individually address a first subset of the at least one drive signal transmitter electrode traces and provide a drive signal to the respective drive signal electrode trace and (2) individually address a second subset of the at least one drive signal receiver electrode traces and connect the respective drive signal receiver electrode trace to an output of the biometric image sensor. In some configurations, the single signal from the controller comprises a first coded control signal, and in response to receiving the single signal the intermediate logic circuit is configured to individually address a subset of the at least one resulting signal receiver electrode traces and communicatively couple the respective resulting signal receiver electrode trace to an first input of the controller. Additionally, the single signal from the controller can comprise a second coded control signal causing the intermediate logic circuit to both individually address a third subset of the at least one drive signal receiver electrode traces and provide a receiver electrode trace received signal to a first output of the intermediate logic circuit and (2) individually address a fourth subset of the at least one drive signal receiver electrode traces and connect the respective drive signal receiver electrode trace received signal to a second output of the intermediate logic circuit. In other configurations, the first output can comprise a first input to a differential amplifier and the second output can comprise a second input to the differential amplifier. For example, the second coded control signal can comprise an output of a shift register set by the controller, connected to control logic routing respective individual pixel location drive signal receiver electrode traces to the respective first output or second output. The second coded control signal can comprise an output of a shift register set by the controller, communicatively coupling the control logic routing respective individual pixel location drive signal receiver electrode traces to the respective first output or second output. Additionally, the intermediate logic circuit can comprise logic circuit transistor switches formed on at least one of the first substrate and the third substrate. The logic circuit transistor can also be configured to such that the switch can comprise thin film transistors formed on the one of the first substrate and the third substrate. Additionally, the intermediate logic circuit can comprise a thin film transistor amplifier formed on one of the first

substrate and the third substrate intermediate a respective drive signal receiver pixel location receiver electrode trace and the intermediate logic circuit.

[0027] Another aspect of the disclosure is directed to a biometric object imaging sensor comprising: a plurality of capacitive gap sensor electrode traces forming an array of biometric sensor imaging pixel locations within a biometric sensing area of the biometric image sensor, at least one of which sensor electrode traces forming a drive signal transmitter electrode trace and at least one of which sensor electrode traces forming a drive signal receiver electrode trace, wherein a change in a drive signal transmitted by a respective at least one drive signal transmitter electrode trace and received by a respective at least one drive signal receiver electrode trace is indicative of a biometric image characteristic at the respective pixel location in the array, the respective drive signal transmitter electrode trace and respective drive signal receiver electrode trace being formed on one of a single side of a first substrate and on opposite sides of the first substrate; a controller contained in an integrated circuit mounted to a second substrate remote from the biometric sensing area and in electrical contact with the sensor electrode traces; an intermediate logic circuit intermediate the controller and the sensor electrode traces in the biometric sensing area, which intermediate logic circuit is at least one of formed on the first substrate and formed on a third substrate mounted on the first substrate, to control an activation sequence for a subset of the plurality of the capacitive gap sensor array pixel locations in response to a single signal from the controller to the intermediate logic circuit. The first substrate and the second substrate comprise a single substrate. Additionally, the single substrate can comprise one of a flexible dielectric and a glass substrate. In at least some configurations, the single signal from the controller can comprise a first coded control signal causing the intermediate logic circuit to one of (1) individually address a first subset of the at least one drive signal transmitter electrode traces and provide a drive signal to the respective drive signal electrode trace and (2) individually address a second subset of the at least one drive signal receiver electrode traces and connect the respective drive signal receiver electrode trace to an output of the biometric imaging sensor. Additionally, the single signal from the controller can comprise a second coded control signal causing the intermediate logic circuit to both individually address a third subset of the at least one drive signal receiver electrode traces and provide a receiver electrode trace received signal to a first output of the intermediate logic circuit and (2) individually address a fourth subset of the at least

one drive signal receiver electrode traces and connect the respective drive signal receiver electrode trace received signal to a second output of the intermediate logic circuit. The first output can comprise a first input to a differential amplifier and the second output can comprise a second input to the differential amplifier. Additionally, in at least some configurations, the second coded control signal can comprise an output of a shift register set by the controller, connected to control logic routing respective individual pixel location drive signal receiver electrode traces to the respective first output or second output. The intermediate logic circuit can also comprise a logic circuit transistor switches formed on at least one of the first substrate and the third substrate. In other configurations, the logic circuit transistor switches can comprise thin film transistors formed on the one of the first substrate and the third substrate. Additionally, the intermediate logic circuit can comprise a thin film transistor amplifier formed on one of the first substrate and the third substrate intermediate a respective drive signal receiver pixel location receiver electrode trace and the intermediate logic circuit.

**[0028]** A biometric imager is disclosed which may comprise a plurality of sensor element traces formed in or on a sensor substrate which may comprise at least a portion of a display screen defining a biometric sensing area and forming in-active pixel locations; an auxiliary active circuit formed in or on the sensor substrate on the periphery of the biometric sensing area and in direct or indirect electrical contact with each of the plurality of sensor element traces; and the auxiliary active circuit providing a signal processing interface between the plurality of sensor element traces and a remotely located controller integrated circuit. The plurality of sensor element traces may form a portion of a one dimensional linear capacitive gap biometric imaging sensor. The plurality of sensor element traces may form the rows and columns of pixel locations in a two dimensional grid array capacitive gap biometric imaging sensor. The auxiliary circuit may comprise a pixel location selection circuit or a pixel signal amplification circuit. The auxiliary circuit may be mounted on a surface of the display screen. The auxiliary circuit may further comprise a separate pixel location selection controller circuit.

**[0029]** Biometric sensors are disclosed. Sensors can be incorporated into a variety of packages, housings and form factors. Additionally disclosed are methods of making sensors. Additionally, biometric sensors incorporatable into a glass touch screen

having an upper surface with resin which allows the signal to pass between a user's finger and a sensor without compromising the signal.

**[0030]** Also disclosed are devices and methods that use high dielectric constant materials that can be mixed with molding resins to boost sensor signal. A signal boosting structure ("SBS"), residing on top of the sensor, can be constructed from the modified resins after the mixing is completed in order to provide mechanical durability without lowering the sensor signal level. It was also found that the noise is less when a certain type of mixed resin is used, resulting in an increase in Signal-to-Noise Ratio ("SNR").

**[0031]** Prior solutions have attempted to increase the maximum allowable thickness of any materials that would come between the sensor and the finger, and 0.07 mm thick glass with approximately 0.01 mm of adhesive or 0.03 mm to 0.04 mm of decorative color coating are recognized as typical topping structures showing acceptable sensor signal levels. With the use of high dielectric constant materials as disclosed herein, the signal boosting structure can be made more thick, e.g., 0.1 mm or even greater.

**[0032]** It will be understood that a biometric object sensor button arrangement core and method of forming the same is disclosed which may comprise a flex material layer; a sensor controller IC mounted on one side of the flex material layer; a metallization layer comprising a plurality of sensor sensing element traces and controller IC input/output traces formed on at least one side of the flex material layer, each in electrical connection with controller IC; an encapsulation layer encapsulating the controller IC to one of the flex material layer and the metallization layer; and a protective layer covering one of the flex material layer and the metallization layer on a surface opposite from where the controller IC is mounted, comprising a dielectric material dispersed with at least one high dielectric material utilizing a dispersant. The biometric object sensor button may further comprise a fingerprint sensor button. The metallization layer may comprise a first metallization layer formed on a first surface of the flex material comprising the sensor sensing element traces and a second metallization layer formed on a second surface of the flex layer opposing the first surface of the flex layer and comprising at least some of the controller IC input output traces. The button arrangement core may further comprise an extension of the flex layer and the metallization layer extending from the encapsulation layer and a further encapsulation of the extension of the flex layer from the button arrangement core and

the extension of the metallization layer from the button arrangement core to form a button arrangement package. A further encapsulation of the extension of the flex layer and a further deposition of dielectric material on the metallization layer may be included to form a button arrangement package. The button arrangement core may further comprise an adhesive layer covering the one of the flex layer and the metallization layer and the extension of the encapsulation of the flex layer and the metallization layer; and a layer of dielectric material adhered to the adhesive layer, which may be corundum and may be deposited by thin film deposition or as a thin crystalline sheet(s). The method may comprise forming a flex material layer; mounting a sensor controller IC on one side of the flex material layer; forming a metallization layer comprising a plurality of sensor sensing element traces and controller IC input/output traces formed on at least one side of the flex material layer, each in electrical connection with controller IC; encapsulating the controller IC in an encapsulation layer formed on one of the flex material layer and the metallization layer; and forming a protective layer covering one of the flex material layer and the metallization layer on a surface opposite from where the controller IC is mounted, comprising a dielectric material dispersed with at least one high dielectric material utilizing a dispersant.

#### **INCORPORATION BY REFERENCE**

[0033] All publications, patents, and patent applications mentioned in this specification are herein incorporated by reference to the same extent as if each individual publication, patent, or patent application was specifically and individually indicated to be incorporated by reference, for all purposes, including the specification, figures and claims as if the entire patent or publication was reproduced entirely herein.

#### **BRIEF DESCRIPTION OF THE DRAWINGS**

[0034] The claimed subject matter is now described with reference to the drawings, wherein like reference numerals are used to refer to like elements throughout. In the following description, for purposes of explanation, numerous specific details are set forth in order to provide a thorough understanding of the claimed subject matter. It will also be understood that the elements disclosed and illustrated in the drawing figures are described in a positional and relational sense in the present application,

e.g., as “top” and “bottom,” “front” and “rear,” “left” and “right” in such nomenclature selected purely arbitrarily and in conformance with the illustrated relationships in the drawing figures and are not intended to delimit any such orientation of the subject matter disclosed when in actual use, or to so limit the appended claims. It will also be evident, however, that the claimed subject matter may be practiced without these specific details. In some instances, well-known structures and devices are shown in block diagram form in order to facilitate describing the claimed subject matter.

[0035] The novel features of the invention are set forth with particularity in the appended claims. A better understanding of the features and advantages of the present invention will be obtained by reference to the following detailed description that sets forth illustrative embodiments, in which the principles of the invention are utilized, and the accompanying drawings of which:

[0036] **FIG. 1** shows schematically components of a portion of a biometric sensor arrangement, such as a 2D grid array fingerprint sensor transmitter drive circuit according to aspects of the disclosed subject matter;

[0037] **FIGS. 2A-B** schematically show components of a portion of a biometric sensor arrangement, such as a 2D grid array fingerprint sensor receiver circuit according to aspects of the disclosed subject matter;

[0038] **FIG. 3** shows a simplified schematic form of a portion of a 2D fingerprint sensor grid array, such as a portion of an X-Y sensor grid according to aspects of the disclosed subject matter;

[0039] **FIGS. 4A-B** illustrate schematic views of a drive circuit for use with a fingerprint sensor grid array such as shown in **FIG. 3**, according to aspects of the disclosed subject matter;

[0040] **FIG. 5** illustrates partly schematically, an arrangement of a biometric sensor 2D sensor formed on a substrate with a controller IC mounted in the same substrate and intermediate circuitry also formed on the substrate or on a layer formed on the substrate, according to aspects of the disclosed subject matter;

[0041] **FIG. 6** shows partly schematically a biometric imaging sensor formed by a 2D grid array of capacitive gap in-active pixel location sensor elements formed on a dielectric substrate according to aspects of embodiments of the disclosed subject matter;

[0042] **FIG. 7** shows a partial schematic of a biometric sensor;

[0043] **FIG. 8** shows part of a schematic of a second configuration of a biometric sensor wherein a molding or filling compound seals the IC and the sides of the glass top plate;

[0044] **FIG. 9** shows a simplified schematic showing an X-Y sensor array block connecting to an IC;

[0045] **FIG. 10** shows a cross-sectional view of a compact construction for a 2D swipe or placement grid array fingerprint sensor;

[0046] **FIG. 11** shows an example of a metal layout for a sensor;

[0047] **FIGS. 12A-B** show transmitter or received electrode traces;

[0048] **FIGS. 13A-B** shows cross-sectional schematic view of sensors;

[0049] **FIGS. 14A-C** shows a more detailed view of transmitter electrodes/traces and received electrode/traces formed on a substrate and fabrication structure;

[0050] **FIG. 15** shows a manufacturing process for mass producing button constructions;

[0051] **FIG. 16** illustrates a cross-sectional schematic view of a sensor electrode/trace arrangement;

[0052] **FIG. 17** illustrates components inside a form factor, such as a button;

[0053] **FIG. 18** illustrates a laminated copper foil with silver jumpers for a 2D sensor;

[0054] **FIGS. 19A-B** illustrate a chip on glass (COG) package;

[0055] **FIG. 20** illustrates an example of an electrode connected to glass by wire bonding pads;

[0056] **FIG. 21** is a side view of a housing with a chip positioned therein and a coating on top;

[0057] **FIG. 22** illustrates a top view of a sensor and chip configuration;

[0058] **FIG. 23** is a side view of a housing with a chip wherein the top coating fits within a cavity;

[0059] **FIG. 24** is a side view of a housing with a chip wherein a thin disk or plate is attached;

[0060] **FIG. 25** is a side view of a sensor reel with a chip with the copper side down;

[0061] **FIG. 26** is a side view of a sensor reel with a chip away from a sensor;

[0062] **FIG. 27** is a side view illustrating the use of a coating or printing of mixed liquid resin after the button has been built similarly to **FIG. 23**; and

[0063] **FIG. 28** shows a table of results of testing with varying dielectric materials with or without high dielectric material dispersants.

## DETAILED DESCRIPTION

[0064] The following description and the annexed drawings set forth in detail certain illustrative aspects of the claimed subject matter. These aspects are indicative, however, of but one or more of the various ways in which the principles of the claimed subject matter may be employed and the claimed subject matter is intended to include all such aspects and their equivalents. Other advantages and novel features of the claimed subject matter will become apparent from the following detailed description of the claimed subject matter when considered in conjunction with the drawings.

[0065] According to aspects of embodiments of the disclosed subject matter, lower complexity and therefore, generally speaking, lower cost transistors, including TFT transistors made with lower cost TFT technologies, may be used with the sensor array to perform individual pixel signal processing or at least selection and control outside of the pixel array.

[0066] According to aspects of the disclosed subject matter a larger sensing signal may be obtained, e.g., by increasing the signal that is coupled from the transmitter pixel to the finger. This can provide, e.g., an alternative to the multiple receiver approach described above. When incorporating the appropriate logic circuitry in the transmitter line driver circuits that operate on much larger signals than the receiver circuits, the demands on the transmitters (rows in one embodiment) multiplexing circuits can be far less stringent than for multiplexing that is done on the receiver lines, e.g., because they are carrying much smaller signals. Providing in-pixel amplification circuitry can reduce the demands on the receiver circuitry considerably. However, in-pixel amplification, as noted above, can be costly and use a good deal of pixel real estate to implement and the amplification may itself be of relatively low performance, e.g., noisy and lacking in much gain.

[0067] According to aspects of embodiments of the disclosed subject matter a sensor pixel array may be fabricated which does not require any TFT circuitry in the array itself, i.e., at the respective pixel locations, or at least no higher performance TFTs. The extra processing cost of fabricating such higher cost TFT circuitry on the glass can effectively be removed from the fabrication process over the majority or all of the of the array substrate. In addition to controlling which transmitter lines and/or pixels are activated simultaneously, it may be advantageous to activate certain transmitters or combinations of transmitters, including doing so at different voltages to achieve an

improved fingerprint image from the receiver circuits. A best available or optimized combination of signals achieving the desired signal strength (e.g., reducing the noise in the fingerprint image) and fingerprint image resolution, e.g., number of rows and columns may be empirically and/or dynamically determined and utilized. In much the same manner that multiple transmitter/receiver lines can be activated simultaneously to increase the signal strength in a 1D linear sensor element array, multiple receiver lines can also be tied together, e.g., in the readout multiplexer circuit to increase the strength of the signal that is passed on to the receiver line(s) sense amplifier.

**[0068]** Activating multiple transmitter pixels in a two-dimensional fingerprint sensor pixel array can be accomplished in several forms. For two-dimensional sensor arrays, as an example, which are operated in a passive mode, e.g., including no active (such as, TFT) circuitry at each pixel, this can be accomplished in its simplest form by activating more than one transmitter line at a time. As is known, if the transmitter signals are all generated in a single controller integrated circuit (“IC”), or cooperating controller IC, the IC(s) may contain logic circuitry to activate multiple transmitters in specific patterns simultaneously in a fashion similar to the one-dimensional sensor case referenced above.

**[0069]** Alternatively, and according to aspects of embodiments of the disclosed subject matter, the transmitter signals can pass to the sensor array electrodes, e.g., in a sensor array finger sensing area, e.g., through a secondary circuit residing on the same substrate as the sensor array electrodes (which may be a silicon wafer, glass sheet, plastic sheet, or any other dielectric-coated substrate). This can be, e.g., in the form of multiplexer circuitry formed, e.g., of TFTs formed in or on the array substrate or in an added layer, such as a polysilicon layer on the glass, flex, or the like substrate for the sensor array traces, and can be of simple logic design, e.g., requiring fewer or no polycrystalline silicon devices and/or larger device sizes or at least less high performance devices than would be required to implement pixel selection/multiplexing and/or amplification at the pixel cell level. Logic circuitry can be added to the transmitter line multiplexers that precede the analog line driver circuits. In this case specific combinations of outputs from the primary shift register in the transmitter multiplexer may be combined to activate specific patterns of transmitter line drivers, or the shift register itself may be modified to produce a different pattern of output signals.

[0070] A 2D touch sensor and /chip on glass arrangement along with certain packaging techniques can be beneficial for applications of biometric, e.g., fingerprint sensors for use in authentication applications such as on small user electronic devices, e.g., portable cell phone, iPad®, tablets, personal digital assistants, such as Blackberry® mobile devices, etc. According to aspects of embodiments of the disclosed subject matter, the use of mold plastic around the edge of the glass, e.g., in a button configuration, such as may utilize the same glass as a surrounding display screen, such as a touch screen, into which the button may be inserted in an opening in the display screen, advantageously having the same glass and thus the same or relatively the same coefficient of thermal expansion (“CTE”). Electrical connections may be brought out on the side or the back (“underside”) of the button, with the glass exposed on the top side.

[0071] There may be several options for electrical connections as described in connection with the figures below. In one example, a printed circuit board (“PCB”) type design, utilizing, e.g., a small outline package (“SOP”) or small outline integrated circuit (“SOIC”) surface mounted IC, can be bonded to, or inserted into an opening in a glass substrate, which substrate may be the same piece of glass that forms a 2D touch screen and to protective covering for biometric sensor elements/traces, e.g., a 1D or 2D sensor array and which may also include a sensor controller integrated circuit (“IC”). A molded enclosure utilizing suitable materials, such as epoxies or plastics may be formed with the glass exposed on one side. This invention can extend to, for example, use in a shrink small outline package (“SSOP”), such as may employ “gull wing leads”, quarter-size small outline package surface mount packaging (“QSOP”), thin small outline packages (“TSOP”), thin shrink small outline packages (“TSSOP”), etc., as an example, with glass as a top surface.

[0072] For a system in a package (“SIP”) embodiment according to aspects of the disclosed subject matter passive components can be added on the PCB, and complete the construction. According to aspects of the disclosed subject matter chip on glass (“COG”) package concepts may also be applied, e.g., to supplement 2D sensor on glass, or stand on separate embodiments of, e.g., chip on glass packaged embodiments.

[0073] Turning to **FIG. 1**, as an example, one straightforward implementation for such a sensor array can be to place an array **20** of OR gates **22, 24, 26, 28** between the

outputs of a shift register **30** and the line driver transistors **42, 44, 46, 48** as shown in the partial row driver circuit **10** depicted in **FIGS. 2A-B**. The outputs of the OR gates **22, 24, 26, 28** control the transistors **42, 44, 46, 48** to place the transmit signal **60** on the respective transmit line(s)  $T_{X_{n-2}}$ ,  $T_{X_{n-1}}$ ,  $T_{X_n}$ ,  $T_{X_{n+1}}$ , **52, 54, 56** and **58**. This can be done according to the content of the shift register **30** output on each of the outputs **32, 34, 36, 38, 40** of the shift register **30** in each clock period according to the coded content of the bits shifting through the shift register. As an example, if the content of the shift register **30** from top to bottom as shown in **FIG. 1**, and thus the outputs on **32, 34, 36, 38** and **40**, were 0, 1, 1, 0, 0 ..., then the transmitter lines  $T_{X_{n-2}}$ ,  $T_{X_{n-1}}$  and  $T_{X_n}$  would be activated, since the inputs **32, 34** to OR gate **22** would be 0, 1, the inputs **32, 34** to OR gate **24** would be 1, 1, and the inputs **34, 36** to OR gate **26** would be 1, 0. The outputs of the OR gates **22, 24** and **26** would control the selection transistors **42, 44** and **46** to place the transmit signal **60** on the transmit lines  $T_{X_{n-2}}$ ,  $T_{X_{n-1}}$  and  $T_{X_n}$ . Similarly, adjacent transmitter lines  $T_{X_n}$  and  $T_{X_{n-1}}$  could be activated with a bit pattern of 0, 0, 1, 0, 0, resulting in the outputs of the OR gates **24** and **26** connecting transmit lines  $T_{X_n}$  and  $T_{X_{n-1}}$  to the transmit signal **60**.

[0074] It will also be understood by those skilled in the art, that the circuit **10** of **FIG. 1** is merely an example and the 2D sensor array selection/activation/multiplexing circuitry could be fabricated to cover all transmit circuit lines, e.g., all rows of the array or larger numbers of rows, but less than all rows, forming separate sections of rows of the 2D sensor array. Similarly the shift register(s) **30** could contain various bit encoding patterns such as to activate more than two adjacent transmit lines, or transmit lines separated by non-activated transmit lines, etc. The same or different patterns of activation may be implemented in each section of transmit lines controlled by a separate shift register **30**.

[0075] Multiple receiver lines **152, 154, 156, 158** can be enabled with a circuit **10**, as seen in **FIG. 2**, that is very similar to the one depicted above. In such case the line driver transistors **42, 44, 46, 48** can be replaced by pass transistors **142, 144, 146, 148** that simply pass any combination of analog signals from the selected receiver lines  $R_{X_{n-2}}$ ,  $R_{X_{n-1}}$ ,  $R_{X_n}$ ,  $R_{X_{n+1}}$ , **152, 154, 156** and **158** to the receiver's main sense amplifier(s) **160** under the control of the OR gates **122, 124, 126, 128**, based on the outputs **132, 134, 136, 138** and **140** from the shift register **130**.

[0076] The above discussion utilizes convention that transmitter signals are sent on the row lines  $TX_{n-2}$ ,  $TX_{n-1}$ ,  $TX_n$ ,  $TX_{n+1}$  as seen in **FIG. 1** and received signals are received/read out on the column lines  $RX_{n-2}$ ,  $RX_{n-1}$ ,  $RX_n$ ,  $RX_{n+1}$ , as seen in **FIG. 2A**, although the selection circuitry **10**, could be built with the opposite orientation. Also, according to aspects of embodiments of the disclosed subject matter, if the two-dimensional sensor grid array **506** as seen in **FIG. 5**, interfacing with the selection circuitry **10** also is active circuitry, e.g., contains active (such as, semiconductor) elements within each pixel (not shown), e.g., to implement full active matrix operation, additional logic may be placed within a pixel cell to achieve specific patterns of activated transmitter/receiver pixels. If one or more additional (perhaps logic-level) input row or column signals are provided in the array, logic circuits in adjacent pixels can allow specific transmitter pixels near a central target pixel to be activated without activating an entire row's transmitters. While such an approach might increase the sensor readout frame rate, optimal combinations of active and inactive transmitter pixels may be found to improve the signal levels and therefore the overall fingerprint imaging done by the fingerprint image sensor.

[0077] According to aspects of the disclosed subject matter, such sensor arrays can result in significant reductions in cost. Multiplexing the transmitter and/or receiver lines on an auxiliary circuit, e.g., one implemented at or near the sensor array **506**, such as on the same substrate or at least a layer deposited on the same substrate, such as a polysilicon layer in which the TFT transistors of the auxiliary circuit can be fabricated, can eliminate a large fraction of the I/O connections on the controller IC as well as circuitry on the real estate of the controller IC (not shown). This can allow a smaller, coarser, more reliable and less expensive IC and a coarser and more reliable IC-to-substrate attach process to be used. In addition, the die size and cost may also be reduced because IC size and cost is also driven by the number of required I/O pads.

[0078] According to aspects of embodiments of the disclosed subject matter, attempts to reduce the noise levels in a two-dimensional fingerprint sensor array are proposed which, e.g., compare each pixel's signal to an average signal level across another portion or portions of the 2D sensor array. Time dependent, and to some extent spatially dependent, noise that affects many pixels in close proximity in such an array simultaneously can be mitigated, according to aspects of the disclosed subject matter. This may be done, e.g., by effectively subtracting the noise which is obtained by averaging signals from other pixel locations, e.g., the pixels surrounding a target

pixel, from the signal of the target pixel. Other pixels may also be selected, e.g., by empirical and/or dynamic testing to determine pixels whose signals, when selected, will most effectively, most often, most simply, etc. serve to remove the undesired noise from the pixel signal being sampled at the time.

[0079] According to aspects of the disclosed subject matter, an average noise signal obtained from multiple nearby sensor-to-finger capacitance readings positioned in relation to the target pixel's sensor-to-finger capacitance location, e.g., at a transmitter trace/receiver trace crossover point, can be subtracted from the target pixel received signal. This type of averaged noise subtraction can be more effective at compensating for noise and other sources of error, e.g., that might arise from sources outside the plane/area of the sensor, for example, on the surface of the finger or on the surface of the sensor's protective coating, etc. As an example, for passively addressed 2D sensor array **200**, as seen in **FIG. 3**, the average signal for all the pixels **212** in an active row **210** except the target pixel **220** can be obtained by tying together all the other signal lines from the inactive columns **230**, as opposed to the active column **250**, as illustrated in **FIG. 3**.

[0080] A possible shortcoming of existing solutions for accounting for the added capacitance, including parasitic capacitances, due, e.g., to selecting from multiple sensor pixel element locations for activation as transmitter locations and activation as receiver locations is that the receive lines from the selected receiver pixel locations may, individually or collectively or both, be loaded down with lots of background capacitance. This can reduce their sensitivity and/or make the received signal smaller. Sources of background capacitance may include: capacitance between the receiver lines to surrounding metal (like the adjacent or surrounding transmitters or receivers); the capacitance of the switches that multiplex the receivers to a central receiver line; the capacitance of the connection to the ASIC, e.g., at the interconnection bumps and bond pads of the ASIC; the capacitance of the ESD protection structures (i.e., diodes), e.g., under the bond pads of the controller chip and the capacitance of the sensing amplifier on the controller chip. the transmitter state machine

[0081] Addressing the first item, i.e., the capacitance coupling to the surrounding metal, is beyond the scope of the specific corrections addressed in this application. The other four may be mitigated, e.g., by adding an amplifier or buffer built to the signal output line(s). Such a buffer or amplifier, according to aspects of the disclosed

subject matter may be formed on the same substrate as the sensor transmitter and receiver electrode traces of a separate substrate attached to that substrate. This may be done, e.g., utilizing active devices formed on such substrate, e.g., thin-film-transistor (“TFT”) devices on a glass substrate, e.g., between the receiver lines and the rest of the background capacitance.

[0082] Turning to **FIG. 2B**, a modified version of the circuitry shown in **FIG. 2A** is presented. Many sources of background/parasitic capacitance are shown. For example, in a given case, such as, the selection of  $R_{xn}$  **156** as the receiver electrode trace to be connected to the main receiver sense amplifier line **160** adds capacitance (not shown) to the  $R_{xn}$  line **156** at the input side of the switch **146**. The output side of switch **146** also adds capacitance. Additionally, on the output side of the switch **146**, even though all the other switches **142**, **144**, **148** might be turned off, they are still connected to the main receiver sense amplifier line **160** and add capacitance to it. The routing of the main receiver sense amplifier line **160** near other conductors (other metal lines, vias, etc., not shown) adds additional capacitance to the main receiver sense amplifier line **160**. The metal-to-metal capacitance due to the routing of the main receiver sense amplifier line **160** as well as the capacitance from the switches **142**, **144**, **146**, **148**, for illustration purposes are lumped into a single symbolic capacitance.

[0083] At the boundary to the controller IC, e.g., an ASIC **908**, a bond pad **820** on the ASIC **908** can add significant additional capacitance. Under this bond pad **820** inside the ASIC **900** can be ESD protection circuits, shown symbolically as diodes **830** and **831**. The sensing amplifier **840** can also add capacitance. All of these ASIC capacitances, for purposes of illustration are lumped into a single symbolic controller ASIC capacitance **850**.

[0084] According to aspects of the disclosed subject matter reduction in the effect of these capacitances **820** can be achieved. For example, metal-to-metal routing may be carefully controlled, and sometimes the background capacitance can be reduced by eliminating or reducing the shielding around the main receiver sense amplifier line **160**. Although this can reduce the background capacitance and thereby increase the sensitivity of the main receiver sense amplifier line **160**, it can also increase the susceptibility to external noise sources which might otherwise have been blocked by the shielding.

[0085] Another approach may be to reduce the background capacitance, e.g., by reducing the size of the switches, as an example, switches *142, 144, 146, and 148*. However, doing so can also increase the resistance of the switches *142, 144, 146 and 148*, which can substantially reduce the magnitude of the received signal on the receiver sense amplifier line *160*. Still another way to reduce the background capacitance can be, as an example, to reduce the size of the ESD protection circuits *830, 831*. This can, however, have an undesired effect of increasing the susceptibility of damage due to an ESD strike.

[0086] Current packaging and mounting technology, e.g., for biometric object image sensing devices, such as are sold by the assignee of the present application, e.g., where the receiver lines, such as, *152, 154, 156, and 158* are created in metal on a ball grid array (“BGA”) or chip on flex (“COF”) substrate, the methods to reduce background capacitance described above may be the only alternatives, e.g., resulting in increased noise, increase ESD susceptibility, etc). BGA and COF technologies can block or at least limit any ability to put active devices (e.g., transistors) on the substrate, e.g., next to the receiver lines *152, 154, 156, and 158*.

[0087] However, if the sensor array, e.g., *200* in **FIG. 3** with, e.g., receiver electrode traces *152, 154, 156, and 158* is implemented on a glass substrate, then it is possible to use TFT’s to add active devices next to the sensing array, e.g., at the interface between the sensor array *200* receiver electrode traces, e.g., *152, 154, 156 and 158*, and the controller IC *900*. This can, among other things, allow for the inclusion of sampling and/or amplifying circuits, e.g., amplifiers, unity gain amplifiers, or buffers *801, 802, 803, 804* between the receiver electrode trace lines *152, 154, 156, and 158* and the background capacitance *810, 850* described earlier.

[0088] The choice of whether to implement amplifiers, unity gain amplifiers, or buffers at locations *801, 802, 803, and 804* can depend on the quality of the TFTs that can be constructed on the available substrate, e.g., crystalline silicon, poly-crystalline silicon, amorphous silicon, glass (non-crystalline), etc., the physical size of the constructed TFTs, and the proximity of the TFTs to the sensor array, among other things. optimizations of these factors for the specifications for the contemplated TFT’s will be well within the skill of the art, without undue experimentations, but have not been studied by applicants as yet nor has the precise TFT capability(ies) needed, The advantages of aspects of the disclosed subject matter can, however, be understood by those skilled in the art without the specifics of these TFT details. For

current purposes, the elements **801**, **802**, **803**, and **804** as unity amplifiers, otherwise known as buffers, which could consist of, e.g., a single TFT transistor in a source-follower configuration. The advantage being, in part, the TFT is more rugged than an amplifier on an ASIC IC, capable of handling a higher voltage, built on a cheaper substrate than a crystalline silicon wafer substrate, e.g., by deposition technologies typically used for, e.g., printed circuit boards (“PCB’s”), etc. On the other hand, an amplifier constructed, e.g., on a crystalline silicon substrate may have better amplification gain control, larger dynamic range, less noise, etc.

[0089] Whatever is the case, adding buffers **801**, **802**, **803**, and **804** between the receivers **152**, **154**, **156**, and **158** and the rest of the background capacitance **810**, **850**, provides for the receiver electrode traces **152**, **154**, **156**, and **158** to be loaded only by the input capacitance of the respective buffers **801**, **802**, **803**, and **804** and not the background capacitance **810**, **850** of the rest of the system. This can, e.g., substantially increase the sensitivity of the receivers **152**, **154**, **156**, and **158**. The buffers **801**, **802**, **803**, and **804** drive the background capacitance of the rest of the system.

[0090] In such a case, active column **250**,  $C_n$ , contains the active pixel **220** being read, and the signals from all other pixels **212** in the active row **210**, i.e., from inactive columns **230**,  $C_1$  through  $C_{n-1}$  and  $C_{n+1}$  through  $C_m$ , can be combined to obtain an average **270** that can, e.g., be subtracted from the active pixel **220** signal, output **280**, on the column  $C_n$  output line to reduce the noise components in the signal output from the active column **250**,  $C_n$ . The connections that tie together all the average background signal on the column lines  $C_1$  through  $C_{n-1}$  and  $C_{n+1}$  through  $C_m$  can be implemented in TFT circuitry on the sensor array **200** substrate that is part of, or precedes, the column readout multiplexer/shift register circuitry, as seen in **FIG. 4**.

[0091] In **FIG. 4A** there can be seen an example of a selector circuit **300**, including a selection logic circuit, such as shift register **330**. As each shift register output signal,  $SR_{n-1}$ ,  $SR_n$ ,  $SR_{n+1}$ ,  $SR_{n+2} \dots$ , **332**, **334**, **336**, **338**..., is enabled in sequence, as an example, all of the other shift register outputs  $SR_{n-1}$ ,  $SR_n$ ,  $SR_{n+1}$ ,  $SR_{n+2} \dots$ , **332**, **334**, **336**, **338**, can be set low. The enabling (e.g., setting to 1) of each respective  $SR_{n-1}$ ,  $SR_n$ ,  $SR_{n+1}$ ,  $SR_{n+2} \dots$ , **332**, **334**, **336**, **338**, ..., activates the respective one of the receiver traces  $Rx_{n-1}$ ,  $Rx_n$ ,  $Rx_{n+1}$ ,  $Rx_{n+2} \dots$ , of each respective individual active column **250** from among the columns  $C_{n-1}$ ,  $C_n$ ,  $C_{n+1}$ ,  $C_m$ . As an example, as shown in **FIG. 3**,  $C_n$  is active while  $C_{n-1}$ ,  $C_{n+1}$ ,  $C_m$ , ..., are inactive. As an individual column

line  $SR_n$  is enabled, corresponding to column  $C_n$  in **FIG. 3**, the receiver signal  $Rx_n$  is transferred to the primary output signal line **380** through respective selection transistor, i.e., **324**, from among the selection transistors **322**, **324**, **326** and **328**. At the same time all the other lines  $Rx_{n-1}$ ,  $Rx_{n+1}$ ,  $Rx_{n+2}$ , ... , are connected to the background/average signal line **360** through each respective column selection transistor **342**, **346**, **348**, e.g., due to the presence of the inverters **390** on the shift register **330** outputs  $SR_{n-1}$ ,  $SR_n$ ,  $SR_{n+1}$ ,  $SR_{n+2}$  ... , **332**, **334**, **336**, **338**. Additional logic may be incorporated in addition to, or replacing, the selector circuit **300**, e.g., to tie specific patterns of receiver line signals to either or both of the primary output signal line **380** or the background/average signal line **360**.

[0092] There may be benefits to selecting specific combinations of column signals to combine to obtain the average signal level, rather than combining all the pixels in a row. For example, to reduce the impact of noise contributions that have a short distance scale (but larger than the feature sizes the sensor is reading, e.g., as determined by the pitch of the pixel locations in the rows and columns), it may be beneficial to combine the signal from one or several column readout lines adjacent to the target pixel's readout line, either on one side only or on both sides. In other cases it may be preferable to combine only the signals from pixels that are relatively far from the target pixel (more than several pixels (rows or columns) away, for example, such a sensor according to aspects of the disclosed subject matter may result in improved sensitivity, e.g., compared to other passive array fingerprint sensors, e.g., 1D or 2D, and possibly lower cost than active matrix fingerprint sensors, for reasons explained above.

[0093] According to aspects of embodiments of the disclosed subject matter, there may be employed certain methods of incorporating sensor **10** readout circuitry, e.g., along with sensor elements/traces and a controller integrated circuit ("IC"). This concept is extended here to two-dimensional sensors, where the target pixel is the equivalent of an FI line, as discussed in co-pending U.S. Patent Pub **US 2013/0177220 A1** to Erhart, discussed above, and the equivalent of the NI signal is actually an average of multiple pixels near the target pixel (or throughout the entire 2D array).

[0094] According to aspects of embodiments of the disclosed subject matter the number of signal lines that must be routed to the rows and columns of a fingerprint sensor array having a two-dimensional matrix format through the low performance

TFT circuitry on the periphery of the sensor sensing element array can be significantly reduced. The row and column multiplexing, drive and readout circuits can be, e.g., fabricated on a separate glass sheet, e.g., using relatively low performance TFT technology, and can then be bonded as long thin strips along the periphery of the sensor pixel array. This can effectively replace the silicon IC with an IC made on glass, e.g., semiconductor-on-glass, e.g., incorporating, e.g., relatively low performance TFT circuitry, or which is otherwise much less expensive per area than, e.g., fabricating an IC on a silicon substrate using integrated circuit mask work photolithography fabrication processing.

**[0095]** Building the relatively lower performance and more cost effective TFT multiplexing circuitry on a glass substrate that is similar to the primary array's glass substrate, so that both the array glass and multiplexer strip glass have the same or similar coefficients of thermal expansion (CTE), also can simplify the silicon-on-glass IC attach process by eliminating CTE mismatch stresses between the array area glass and the glass substrate of a multiplexing circuit, e.g., a separate IC. The attach process can further be simplified by matching the electrode (trace) pitch of the TFT silicon-on-glass circuitry to the row and column pitch of the sensor pixel array electrodes/traces, which may be coarser than would be expected for an entire integrated circuit made with IC made with semiconductor-on-glass technologies. A glass multiplexer circuit, e.g., made with TFTs, could be thinned prior to being attached to the array sensor electrode/traces, or it could be fabricated on thin (0.025 – 0.250 mm) glass initially, either in flexible form or while temporarily adhered to a carrier sheet, or otherwise, to facilitate processing.

**[0096]** According to aspects of embodiments of the disclosed subject matter, advantages of this form of construction for the sensor array traces and periphery circuitry, can be, e.g., for a 2D array matrix format fingerprint sensor that does not require any or at least any high performance TFT circuitry at each pixel, added row and column circuitry, such as row and column multiplexer circuitry, that can easily and at little added cost, be added to the glass substrate, dramatically reducing the number of signal lines along the ultimate periphery of the sensor pixel array, while avoiding the cost of a TFT process for the entire sensor pixel array area.

**[0097]** Should the primary sensor pixel array need to incorporate active TFT circuitry, if this circuitry can be implemented with a TFT process that is significantly less expensive than a higher performance TFT process, which may be required for the row

and/or column multiplexer circuits, such a method could still be used to allow the sensor pixel array to be fabricated at a lower cost (for example amorphous silicon or metal oxide TFTs), while attaching the higher performance TFT multiplexer ICs to the peripheral circuitry to provide the required higher performance TFTs only where they are needed. Such can reduce the overall cost of the fingerprint image sensing device. Using a glass substrate for the multiplexer IC fabrication also, e.g., allows the CTE of the multiplexer IC to be matched to the CTE of the fingerprint pixel sensor array sensor elements, permitting more flexibility and a wider process window for the attachment process.

[0098] Turning now to **FIG. 4B**, according to aspects of embodiments of the disclosed subject matter, the just discussed advantages can be achieved also with circuitry containing “double throw” switches, such as switches **322** and **342** in combination and **334** and **344** in combination, **326** and **346** in combination and **328** and **348** in combination. Such “double-throw” switches, e.g., according to the signal present in the shift register **330**, supplied by the ASIC controller **900** can connect a respective receiver electrode trace  $R_{xn-1}$ ,  $R_{xn}$ ,  $R_{xn+1}$  and  $R_{xn+2}$ , etc. to one or the other of the sense amplifier line **360** or **380**. In that regard, the overall content of the shift register **330** could be considered a “single signal” from the controller, i.e., one signal controlling a plurality of single throw switches in the case, e.g., of **FIG. 2B**, and a plurality double throw switches in the case of **FIG. 4B**, or the individual shift register positions could be consider a “single signal” from the controller, controlling one single throw switch (e.g., **FIG. 2B**) or one double throw switch (e.g., **FIG. 4B**).

[0099] In **FIG. 4B** both main receiver sense amplifier lines **360**, **380** can have their own set of background capacitances. Only one set of buffers **801**, **802**, **803**, **804** would be necessary to drive both respective switches **322** and **342** in combination, **334** and **344** in combination, **326** and **346** in combination and **328** and **348** in combination, in the “double throw” configuration and any background capacitance **810**, **850** on the other side of the switches **322** and **342** in combination, **334** and **344** in combination, **326** and **346** in combination and **328** and **348** in combination.

[00100] Each sense amplifier line **360**, **380** can have its own separate ASIC amplifier **840**, the output of one being connected to, e.g., a first input to a differential amplifier and the output of the other being connected to, e.g., a second input to the differential amplifier, e.g., for noise reduction. It will be understood by those of ordinary skill in the art that, e.g., depending on the number of receiver electrode traces

used for noise reduction that are connected to the amplifier **840** on the sense amplifier line **380**, as compared to, e.g., only one or so connected to the amplifier **840** on the sense amplifier line **360**, there may have to be an adjustment to the output of the respective amplifier(s) so as not to overload one input to the ultimate differential amplifier (not shown) with respect to the other. This may be done by, e.g., preselecting a number of receiver electrode traces to be connected to each of output sense amplifier line **360** and **380** and selecting the gain of the amplifier **840** on line **360** with respect to the gain of the amplifier **840** on line **380**. This could also be done dynamically as will be understood by those skilled in the art by dynamic gain adjustment circuitry (not shown) based upon the relative numbers of receiver electrode traces connected to each amplifier **840**, i.e., connected to each respective sense amplifier line **360**, **380**. Other means of accomplishing this balancing could be done, e.g., without using a differential amplifier at all, e.g., digital to analog conversion circuitry (not shown) could be connected to the outputs of the respective amplifiers **840** on lines **360** and **380**, and determining the output of the ASIC could be done digitally, including the necessary balancing.

**[00101]** It will be understood by those skilled in the art that the present application discloses a biometric (fingerprint) image sensing system and method that can, among other things, correct or at least alleviate problems associated with addressing hundreds or even thousands of sensor element electrode traces, e.g., in a 1D passive capacitive gap sensor array or a 2D passive capacitive gap sensor array, or subsets of such sensor element electrode traces. This may be done, e.g., by using intermediate circuitry, e.g., logic circuitry, disposed between the individual sensor element electrodes traces and an IC controller controlling the biometric image sensor which is configured to, based on a “single” command from the IC, individually address a first subset of electrodes to receive a resulting signal and individually address a second subset of electrodes to receive a noise metric signal, each used in a differential measurement with the resulting final output signal comprising an output of the biometric image sensor.

**[00102]** The biometric (fingerprint) image sensor may comprise a processing system configured to sense the biometric (fingerprint) image at biometric image pixel locations within an array of pixel locations and provide sensor output signals for a controller doing the processing to recreate the biometric (fingerprint) image from the pixel location output signals. The biometric image sensor may comprise a plurality of

sensor elements formed by sensor element electrode traces configured to capacitively couple a drive signal applied to an input object (finger) at a pixel location and received, after being capacitively altered by passing through the biometric object (finger), on a drive signal receiver electrode trace for the respective pixel location.

**[00103]** According to aspects of the disclosed subject matter, intermediate logic circuitry can be utilized to couple to the processing system (e.g., controller ASIC integrated circuit) and the sensor element pixel element traces. The intermediate logic circuitry, e.g., can be configured to couple at least one sensor element electrode trace(s) to a first input of a differential amplifier in the ASIC, and couple another sensor element electrode trace(s) to a second input of the differential amplifier in the ASIC. The processing system ASIC may be configured to switch the intermediate logic to couple a different second sensor element electrode trace(s) to the first differential amplifier input and couple the another sensor element electrode trace(s) to the second input of the differential amplifier based on a single control signal sent from the ASIC to the control logic, e.g., forming a multiplexer (“MUX”) in the intermediate logic circuitry.

**[00104]** According to additional aspects of the disclosed subject matter, by utilizing thin film transistor (“TFT”) logic to control the timing of the transmitters, a split transmitter state machine may be created, i.e., wherein half of the transmitter state machine is on the ASIC integrated circuit silicon die and half of the transmitter state machine is on the substrate containing the sensor element electrode traces (or attached to a substrate containing the sensor element electrode traces) in the form of TFT logic. As such, by way of example, an amplifier may be formed on each pixel location drive signal transmitter line and on each drive signal receiver line, e.g., for signal smoothing, signal boosting or the like. In addition, advantageously, one die can be created, e.g., containing the ASIC and intended to be mount to and/or be packaged in a different package, than contains the substrate(s) including the sensor element electrode traces. According to aspects of embodiments of the disclosed subject matter, such ASIC can be designed and manufactured to be “highly programmable”, e.g., enabling the changing of the transmitter drive signal lines firing timing and/or order to accommodate connection to other ICs, circuitry, etc. in the overall biometric imaging sensing and recreation system, e.g., accommodating different packages and interconnections.

[00105] A buffer/unity amplifier may be coupled to respective receiver electrode trace line(s) (e.g. in a source follower configuration) to transition the received modified drive signal into the ASIC, to accommodate proper processing of such signal(s). ESD robustness can be facilitated, e.g., by removing diodes on the ASIC. By selecting the properties of the TFT's used as the transmitter drive signal medium or receiver received drive signal medium, or both, the level of such signals may be increased, e.g., because such TFT's external to the ASIC can have higher voltage capability. Instead of utilizing high voltage I/O circuitry, e.g., buffers and high voltage step downs and the like, on the ASIC silicon, according to aspects of embodiments of the disclosed subject matter level translator TFT's external to the ASIC can be utilized, e.g., to produce and handle drive signals and received signals at higher voltages than the ASIC can handle. Higher voltages make the signal larger. It is harder to increase such signals within the ASIC.

[00106] In addition, it will be understood by those skilled in the art that by using TFT switches to select multiple groups of receivers the intermediate logic circuitry may be utilized to, e.g., perform functions outside the ASIC that can benefit the capture and processing of the biometric (fingerprint) image. As an example, the TFT's can be utilized, as disclosed in the present application to do code division multiplexing ("CDM") encoding of the transmitter electrodes trace inputs and receiver trace output destination(s) and the like. This can, e.g., be used to accomplish choosing which receiver electrode trace received signal goes to, e.g., the positive input of an amplifier, e.g., a differential output amplifier and which receiver electrode trace received signal(s) goes to, e.g., the negative input of the differential amplifiers. Such code division multiplexing may be done, e.g., by simply generating a coded signal to the intermediate logic circuitry to set up the multiplexing paths according to the coded signal, e.g., contained in a register the outputs of which control the outputs of the logic circuitry, as noted in the present application.

[00107] It will also be noted that the sensor elements can be coupled to/adhered a sensor substrate surface using a high K material.

[00108] As can be seen in FIG. 5, a fingerprint sensor 500 may be constructed as depicted in FIG. 5. Here the fingerprint sensor pixel sensor electrode/tracer array 506 can contain all the row and column sensor signal electrodes/traces (not shown), and could include lower performance active TFT sensor pixel circuitry (not shown), if needed, e.g., for reset, preloading, etc., but avoiding more exact and precise

transistor requirements, e.g., for amplification, individual cell selection, control, etc., i.e., multiplexing, etc. A row multiplexer **510** and a column multiplexer **520**, respectively, may be attached to row output lines **512** from the sensor array **506** rows (not shown) and column output lines **522** from the sensor array **506** columns (not shown). these may be TFT-on-glass ICs that are, e.g., formed on the sensor substrate **502** or formed on a separate piece of glass (not shown) and bonded to the sensor substrate **502**, or may even be a separately formed chip-on-glass (“COG”) multiplexor IC mounted on the sensor substrate **502**, e.g., if transparency is not an issue in the areas covered.

[00109] An optional controller IC **504**, e.g., including the sensor controller circuitry, e.g., for generating the drive signals, and timing of the delivery of the drive signal to transmitter drive lines, and receiver amplification and timing and other input/output control and the like, can also be mounted on the sensor substrate **502**. Otherwise the optional controller IC **504** can simply contain some additional interface circuitry formed with the less costly TFT transistor technology may interface the fingerprint sensor **500** with a remotely housed and mounted controller IC (not shown) and may also be mounted on/bonded to the sensor substrate **502** if that functionality is not already provided in the row or column multiplexer(s) **510**, **520** or multiplexer ICs **510**, **520**.

[00110] The TFT multiplexer circuits **510**, **520** and/or optional IC **504** could be fabricated on the sensor substrate **502** glass with any TFT technology that provides the necessary TFT performance, such as low temperature poly silicon (“LTPS”), e.g., where transistors are formed in or on an amorphous layer of a dielectric, such as silicon dioxide (SiO<sub>2</sub>), or melted amorphous silicon forming a generally coarsely grained polysilicon layer, transparent metal oxide TFTs such as Zinc Oxide (ZnO) or Indium Gallium Zinc Oxide (IGZO), or possibly even amorphous silicon or organic TFTs. More complex circuitry and or TFT devices may be formed in, e.g., polycrystalline silicon, e.g., as may be formed by laser crystallization of amorphous silicon to form larger or non-existent grain boundaries, or the like processes. The TFT-on-glass ICs would be bonded to the sensor pixel array substrate **502** with conventional IC attach techniques, including conductive (anisotropic or isotropic) or insulating adhesives, flip chip, solder ball or like processes.

[00111] It will be understood that the fingerprint sensor **500** may be formed on a glass substrate that form, e.g., a portion of a display touchscreen or of the same

material as such a touchscreen and intended for insertion into an opening formed in such a touchscreen. The array **506**, with its sensor elements, multiplexers **510**, **520** and optional IC **504** may be formed on/bounded to (either as separate strips of glass or other material, or separate ICs) on the inside of the touchscreen, i.e., opposite from the surface touched by a user. Products manufactured with the above described aspects of the disclosed subject matter can be expected to cost less than those which use high performance TFT technology, e.g., over the entire sensor pixel array substrate **502**.

[00112] Referring now to **FIG. 6**, a diagrammatic view of one embodiment of a 2D grid array sensor **600** configured according to aspects of embodiments of the disclosed subject matter is illustrated by way of example. In this configuration, pickup/receiver electrodes/lines or top plates/traces **602** may be positioned on an insulating dielectric substrate layer **604** and configured to transmit a signal into a surface of an object located in close proximity to the pickup/receiver electrodes/traces **602**. Drive lines or bottom electrode plates/traces **606** can be positioned juxtaposed to and substantially perpendicular to the pickup electrodes/traces **602** and can be located on an opposite side of the a insulating dielectric substrate **604** to form a 2D grid array if pixel locations **620** at the crossover points of the pickup electrodes/traces **602** and drive electrodes/traces **606**. The pickup electrodes/traces **602** can be configured to receive the transmitted electromagnetic fields, as shown in **FIG. 6**, modified by the impedance characteristics on an object placed within the range of those electric fields.

[00113] **FIG. 6** further illustrates how the electromagnetic fields can extend between the drive electrodes **606** and the pickup electrodes **602** through the dielectric substrate **604**. Without an object within proximity, the electric field lines generally can be uniform within the sensor structure and between the different electrodes **602,606**. When an object is present, such as a finger of a user, a portion of the electric field lines can pass through the finger and can be absorbed by the finger and do not return to the pickup electrodes **602**.

[00114] In operation, the drive electrodes **606**, can be driven by a schematically illustrated high frequency alternating current (or pulsed square wave voltage source, or the like) **610**, illustrating such drive electrode **606** being individually activated. A drive electrode **606**/pickup electrode **602** pair **620** can be activated by selecting a column formed by a pickup/receiver electrode **602** that is activated, i.e., connected to an output for processing of the signal at the pixel **620**. The result is a circuit that

transmits electric field from active drive plate 606 into the combined dielectric of the insulating layer 604 and the finger (not shown) via the electric field lines in the vicinity of the crossover point 620, and received by the active pickup electrode 602. Some of the field lines can be captured by, or at least modified by, e.g., having a capacitive impedance changed by, the object when it is placed in the vicinity the active electrode pair 620. Variations in the finger, such as peaks and valleys and other features of fingerprint on the finger, can be detected and captured electronically by capturing and recording the resulting electric field variations occurring at respective crossover locations 620 of the drive electrodes 606 and pickup electrodes 602. Similar to common capacitance based placement sensors, the sensor can capture a type of image of the fingerprint surface electronically, and generate a representation of the features and characteristics of the fingerprint in the fingerprint sensor example described according to aspects of embodiments of the disclosed subject matter.

[00115] In this configuration of FIG. 3, only one active electrode pair is illustrated. However, the embodiment is not limited to this particular configuration, where one single electrode pair, several electrode pairs, or even all electrode pairs may be active at one time for different types of operations and signal processing to gather the individual pixel data for the reconstruction of a fingerprint image. In practice, it may be desirable for less than all of the electrode pairs to be active at a given time, so that any interference that may occur between close-by pixels would be minimized. In one embodiment, a drive electrode 606 may be activated, and the pickup electrodes 602, e.g., in a given column of pickup electrodes 602 may be scanned one or more at a time so that a column or columns pixel locations can be captured along the respective drive electrodes and pickup electrodes as they are paired along a column of crossover locations 620.

[00116] In general, in operation, each area over which a particular drive electrode 606 overlaps a pickup electrode 602 in the 2D grid array, with a separation of the insulating dielectric substrate 604 is an area that can capture and establish a sensing location that defines characteristics or features of a nearby fingerprint, e.g., in the vicinity above that area. Since there exist multiple sensing locations over the area of the 2D sensor 600 grid array, multiple data points defining features or characteristics of a nearby fingerprint can be captured by the sensor 600 configuration. Thus, the sensor 600 can operate as a planar two-dimensional sensor,

where objects, such as fingers, located on or about the sensor **600** can be detected and their features and characteristics determined.

[00117] It will be understood by those skilled in the art that the disclosed subject matter provides a biometric authentication system wherein a biometric image sensor can be incorporated into a user authentication apparatus providing user authentication, e.g., for controlling access to one of an electronic user device or an electronically provided service. The electronic user device may comprise at least one of a portable phone and a computing device. The electronically provided service may comprise at least one of providing access to a web site or to an email account. The biometric image sensor may be incorporated into a user authentication apparatus providing user authentication for controlling an online transaction. The user authentication apparatus may be a replacement of at least one of a user password or personal identification number. The user authentication apparatus may be incorporated into an apparatus providing user authentication for controlling access to a physical location, or providing user authentication demonstrating the user was present at a certain place at a certain time. The user authentication apparatus may be incorporated into an apparatus providing at least one of a finger motion user input or navigation input to a computing device. The user authentication apparatus may be incorporated into an apparatus providing authentication of the user to a user device and the performance by the user device of at least one other task, e.g., specific to a particular finger of the user. The user authentication apparatus may be incorporated into an apparatus providing user authentication for purposes of making an on-line transaction non-repudiable.

[00118] It will be understood by those skilled in the art that the disclosed subject matter may comprise a biometric imager which may comprise a plurality of sensor element traces, e.g., formed in or on a sensor substrate, which may be a glass or glasslike dielectric and may comprise at least a portion of a display screen, e.g., in a user device, such as a hand held user communication and/or computing defining a biometric sensing area and forming in-active pixel locations, such as are shown in **FIG. 6**; an auxiliary active circuit, such as the multiplexers shown in **FIGS. 1, 2, 4** and **5**, formed in or on the sensor substrate on the periphery of the biometric sensing area and in direct or indirect electrical contact with each of the plurality of sensor element traces; and the auxiliary active circuit providing a signal processing interface between the plurality of sensor element traces and a remotely located controller

integrated circuit, such as a sensor controller IC. The plurality of sensor element traces may form a portion of one dimensional linear capacitive gap biometric imaging sensor. The plurality of sensor element traces may form the rows and columns of pixel locations in a two dimensional grid array capacitive gap biometric imaging sensor, such as is shown in **FIG. 6**. The auxiliary circuit may comprise a pixel location selection circuit or a pixel signal amplification circuit such as is shown in **FIG. 5**. The auxiliary circuit may be mounted on the surface of the display screen. The auxiliary circuit further may comprise a separate pixel location selection controller circuit such as is shown in **FIG. 5**.

[00119] Turning now to **FIG. 7** there can be seen, partly schematically, an example of a biometric sensor *1110* for sensing a biometric, such as a fingerprint from a user finger *1120*. The sensor may be formed on the surface of a top glass *1112*, which may be part of a display screen, such as a touch screen. On the underside of the glass layer *1112* over which the finger *1120* of the user may be placed or swiped, may be formed a layer *1114* of material, which may be a dielectric and may be flexible, such as a film of Kapton® tape, which may have sensor element electrodes/traces formed on one or both opposing surfaces and may also have mounted thereon, e.g., by a chip on film (COF) or flip chip mounting technique a sensor controller IC *1116* to the substrate containing the sensor element electrodes/traces. As noted in this application, for some embodiments, the entire assembly may be on the order of less than 1 mm in thickness H, e.g., on the order of 0.1 mm in thickness, especially for COF types of packaging when considered without the thickness of the IC, such as when the IC is separate from the sensor. Also depending on acceptable signal level, the thickness may be on the order of 2 mm or even thicker, e.g., for flip chip mounting packages.

[00120] **FIG. 8** shows partly schematically a second configuration *1110* similar to that of **FIG. 7** wherein a molding or filling compound, e.g., epoxy *1130* seals in the IC *1116* and the sides of the glass top plate *1112* and allows for the formation of electrical contacts *1132* on the sides of the button assembly *1110* and *1134* on the underside of the assembly *1110*, which may, as explained in more detail below, be electrically connected to the IC input/output (I/O) connectors and/or sensor electrodes/traces.

[00121] A 1D or 2D sensor on glass (SOG) can have passive elements, such as resistors or capacitors, e.g., formed into a single package, which can allow for the

most flexibility, e.g., minimizing sensing location (pixel size), border (i.e., for mechanical considerations such as bezel, lowered manufacturing costs (e.g., piggy-backing on touchscreen panel formation), and smallest form factors (height, width, etc.). According to aspects of embodiments of the disclosed subject matter existing processes in both touch screen sensor fabrication (Young Fast) and assembly (STARS), with a few particularized steps, e.g., forming a planarized dielectric, and metallization for flip chip constructions are readily available.

[00122] According to aspects of embodiments of the disclosed subject matter, a quite small “round button” fingerprint sensor for a given pixel count and sensor area can be achieved, and also the flexibility exists to form any shape, e.g., round, square, square with rounded corners, etc., complimenting a number of designs for authentication biometric sensors, especially for user mobile devices, such as those employing touchscreen displays.

[00123] Referring again to **FIGS. 7** and **8** the materials mentioned for each layer in those FIGS. can be substituted for by like material that yields the same function(s). For instance, the glass layer **1112** can be substituted for by non-conductive plastic such as Polycarbonate (“PC”), Poly(methyl methacrylate) (“PMMA”), a transparent thermoplastic, often used as a lightweight or shatter-resistant alternative to glass, Polyethylene terephthalate glass (“PET”), corundum such as sapphire or ruby, etc. provided the thickness of the material is appropriately adjusted to yield adequate signal strength and thus biometric sensing through the glass **1112**.

[00124] **FIG. 9** shows a simplified schematic showing an X-Y sensor array **1140** connecting to a controller IC **1116**. The transmitter electrode traces X1, X2, X3, ... Xn-1, Xn **1142** and the receiver electrodes/traces Y1, Y2, Y3, ... Yn-1, Yn **1144** form a two dimensional sweep or placement biometric sensor array.

[00125] **FIG. 10** illustrates a cross sectional view of a compact construction for a 2D swipe or placement grid array fingerprint sensor array **1110**, e.g., with flip-chip bonded sensor controller IC. In this construction, there can be, as an example, three metal layers and two isolation dielectric layers forming a 2D sensor element layer **1114**. An example of metal layout is provided in **FIG. 11**. An X metal layer **1150**, e.g., containing the transmitter electrodes/traces, e.g., formed on a dielectric layer **1152**, e.g., a flex tape, e.g., made of Kapton® tape, with a second receiver electrode/traces metal layer **1154** opposite the transmitter electrode/traces

*1150*. An additional dielectric layer *1156* can be connected to the sensor IC controller through ball grid array or solder grid array balls/bumps *1160* and associated vias through the dielectric layer *1156*.

[00126] Several criteria can be utilized in selecting the pitch and/or thickness of the transmitter and receiver metal electrode/traces *1150, 1154*, dielectric *1152, 1156* material, and cross-over point size and shape, etc. in order to achieve optimum performance, ease of manufacturing, and lowest cost. For example, a screen-printed “pattern” of dielectric islands *1146*, as also illustrated schematically in **FIG. 12A** can be screen-printed on the “pattern” of metal transmitter or receiver electrodes/traces *1142, 1144* in order to separate the transmitter and receiver electrodes/traces *1142, 1144* at the crossover points *1146*, with a minimum of manufacturing cost. **FIG. 12B** illustrates schematically a case in which the dielectric layer *1170* can be deposited, e.g., as a spin-on over a large area, and then etched back to form the rectangular or other shaped dielectric layers *1170* formed intermediate the transmitter and receiver electrodes/traces. Contact holes *1172* can be formed in the dielectric islands *1170*, e.g., with a mask and etch process, e.g., in order to make connection to the under-lying metal layer, e.g., the receiver layers *1144*.

[00127] **FIG. 13A** shows a cross sectional schematic view of a glass mounted sensor array *1110* according to aspects of embodiments of the claimed subject matter which illustrates a simplified drawing of a “compact” form factor for a 1D or 2D sensor *1110* with a controller IC *1116* mounted on a sensor electrode/trace arrangement layer *1114*, e.g., as illustrated in **FIG. 7** or **FIG. 10** above, intermediate and mounted to a glass layer *1112* and a controller IC *1116*, e.g., attached to the sensor element arrangement *1110* by a flip chip COF mounting technique.

[00128] **FIG. 13B** illustrates schematically an alternative similar arrangement that can be achieved with one less layer of metal, e.g., resulting in lower cost manufacturing process. The construction in **FIG. 13B** may be suitable for a larger format such as on a cover-glass of the mobile unit, in which the 1D or 2D sensor *1110*, which can be made of transparent materials, plus flip-chip controller IC *1116* could be located near an actual or virtual home button or other icon(s), since the opaqueness of the controller IC can be located away from the sensor elements/traces layer *1114* and thus also from the home button or icon(s). This latter arrangement, however, may lack some compactness.

[00129] FIG. 14A shows in more detail an arrangement similar to the schematic of FIG. 13A, as is discussed in more detail in one or more of the above noted co-pending applications of the assignee of the present application, wherein the sensor elements/traces layer, i.e., the transmitter electrodes/traces 1142 and receiver electrodes/traces 1144, may be formed on one side of a substrate, e.g., a foldable flex tape 1180. The sensor controller IC 1116 may be mounted, e.g., by flip chip mounting onto the same side or opposite side of the substrate 1180, and the “wings” 1182, 1184 containing the transmitter electrodes/traces 1142 and receiver electrodes/traces 1144 folded back over the chip mounting region where the controller IC 1116 is mounted to form a structure like the schematic of FIG. 7A. That is, the controller IC 1116 will be amidst the 2D grid array sensor sensing area, mounted on one side or the other of the region of the substrate 1180.

[00130] FIGS. 14B(1), 14B(2) and 14B(3) show this fabrication assembly process in more detail. After the transmitter electrodes/traces 1142 are formed on the “wing” 1184 and the receiver electrodes/traces 1144 are formed on the “wing” 1182 a layer of dielectric and adhesive or dielectric/adhesive 1101 may be formed on the portion of the substrate 1180 containing the sensor controller IC 1116, with perhaps only adhesive necessary if the sensor controller IC 1116 is mounted on the opposite side of the layer 1180 to which the adhesive is applied, with the layer 1180 itself perhaps being a dielectric. The “wing” 1184 can then be folded over the region 1190 containing the sensor controller IC 1116. Another layer of dielectric and adhesive or dielectric/adhesive (not shown) can then be placed over the “wing” 1184 and the “wing” 1182 folded over the “wing” 1184 to form the structure of FIG. 13A.

[00131] FIG. 14C shows in more detail a fabrication structure which is schematically illustrated in FIG. 13B. The sensor electrode/traces layer structure 1414 for the transmitter electrodes/traces and the receiver electrodes/traces structure are respectively formed on opposing sides of a substrate 1480 to form the 2D sensor array and the sensor controller IC 1416 is mounted on one side or the other of the substrate 1480, which may also contain, as illustrated, electrical connections 1400 from the remotely positioned sensor controller IC 1416, e.g., respectively, for the transmitter electrode/traces 1142 on one side of the substrate 1480 and the electrical connections 1402 between the receiver electrodes/traces 1144 on the opposite side, brought to the same side through vias in the substrate 1480. Also seen are connectors 1410 for connecting the flexible substrate 1480 to a package or device lead

frame arrangement for connection of the sensor apparatus *1410* to another electronic device, which may include anisotropic conductive film (“ACF”) bonding. **FIG. 14C**, as noted, shows a typical layout of a 2D sensor *1410* with controller IC *1416* placement next to the array traces structure *1414* formed on opposite sides of the substrate *1480* to illustrate the form factor shown by way of example in in **FIG. 13B**. The bonding pads *1412* can be laid out as “bonding” pads distributed around the periphery, e.g., to allow for wire bonding to the lead frame in a standard IC package processes.

[00132] **FIG. 15** shows schematically a manufacturing process for mass producing button constructions according to aspects of embodiments of the disclosed subject matter. The buttons can be formed on a glass panel *1530* such that the panel *1530* forms the substrate *1520* corresponding to substrate *1112* in **FIG. 13A**, with the sensor IC *1116* attached, as there shown, and having the electrodes/traces layer structure *1114*. Each button *1110* can then be individually cut from the larger glass panel *1530* to form, e.g., the button of the construction shown in **FIGS. 7** and **13A**. As an example, in **FIGS. 15** and **17**, circular glass button shapes may be cut from a larger sheet of glass or other suitable material, e.g., panel *1530* in **FIG. 15** and *1710* in **FIG. 17**. In the button arrangement *1700* of **FIG. 17**, the traces (not shown), on the opposing side of the glass substrate *1710* in **FIG. 17** can be connected by connectors *1704* to the controller IC *1716*, e.g., through vias (not shown) in the substrate *1710* cut from the panel *1530*. Some or all of the connectors *1704*, e.g., illustrated as connectors *1720* may be connected to wire bonds *1722* and such wire bonds *1722* in turn be connected to a connector *1724* on another device. A passive device *1706* may be connected to the glass panel *1710* in **FIG. 17** by a connector *1708* on the glass panel *1710*, e.g., connected to a trace (not shown) on the opposite side of the panel *1710* to the controller IC *1716*.

[00133] **FIG. 25** shows a portion of a manufacturing process for a button arrangement *2500* according to aspects of an embodiment of the disclosed subject matter. The button can contain a sensor with an Application-specific Integrated Circuit (“ASIC”) controller IC mounted on an opposite side of a substrate from the sensor traces (not shown). The IC *2516* can be mounted to a metallization layer *2520*, which may be made of deposited and etched conductive material, such as copper (Cu) forming sensor input/output (“I/O”) traces (“copper (“Cu”) side down” formed on a substrate *2504*. The substrate *2504* may be formed of a flexible material coming from

a reel of flexible material, which may be in the form of a flex tape or sheet (suitable for multiple button arrangements **2500** to be formed using the flexible material across the width of the flexible sheet. The IC **2516** may be mounted on the flex tape/sheet by a COF mounting style, which may include an underfill sealant **2522** and may be further sealed to and adhered to the flexible tape/sheet **2504** by an encapsulant filler material, such as epoxy **2530**, which may be deposited, as the flexible tape/reel **2504** moves past an encapsulation station, by, e.g., a stencil printing process. Alternatively, the fingerprint sensor sensing element electrodes/traces may be formed in the same copper layer **2520** as the IC I/O electrodes/traces.

[00134] The button arrangement **2500** may then be passed under a dielectric printing station, or the reel can be flipped and the dielectric deposition station positioned under the reel tape/sheet for the deposition of a dielectric layer **2502**, e.g., formed of, as an example, a resin with interspersed high dielectric constant material(s), such as by a screen printing process. The dielectric layer **2502** then forms a protective and insulative layer over the fingerprint sensor sensing element traces formed, e.g., by a metallization layer deposition and etch process on the surface of the flexible material tape/sheet **2504** opposite from the side to which the IC **2516** is mounted. As noted above, such a process may be referred to as a copper (“Cu”) down process because of the position of the surface of the flexible tape/sheet receiving the copper deposition for mounting of the IC **2516** within the button **2500** arrangement.

[00135] FIG. 26 illustrates as an example a “copper (‘Cu’) up” button arrangement **2600’**. In the arrangement **2600’**, the copper deposition is on the surface of the flexible material tape/sheet **2604** on the top of the tape/sheet **2604** and, thus, above the filler material **2630** forming the rest of the button **2600’** structure. The filler material **2630** is formed on the reverse side of the tape/sheet **2604**. The fingerprint sensor sensing element electrodes/traces can be formed on the opposite side of the tape/sheet **2604** and extended (not shown) in some embodiments outside of the button arrangement on the tape/sheet **2604** (e.g., as seen as an example in FIGS **21-24** and **27**, for electrical connection to devices, e.g., a remote IC or a device in which the button is mounted. Such an arrangement can be referred to as a “copper (“Cu”) down” button arrangement.

[00136] FIG. 21 shows by way of example a Cu down button arrangement after further manufacturing processes, to add material to the basic button arrangements formed as discussed in regard to FIGS. **25** and **26**. With the Cu side

down, the ASIC IC **2116** can also be incorporated into the button structure. Additional filler material, either of the same type as molded in the processes described in regard to **FIGS. 25** and **26** or of a different material with similar or the same performance characteristics may be added, e.g., to the right side of the button arrangement **2100** as shown in **FIG. 21**. This additional material may be added by putting the button arrangement **2500** of **FIG. 25** into an injection molding machine to add this additional material encapsulating an extension of the Cu down flex tape **2504** and copper metallization layer **2520**. Such an extension may further extend outside of the package **2200** for the placement of lead lines **2212** as illustrated in **FIG. 22**.

[00137] **FIG. 23** illustrates a formation, e.g., in an injection molding machine of added material, e.g., the same epoxy as for the filler **2330** as in **FIGS. 25** and **26**, or some other suitable material, on both ends of the core button arrangements **2500** of **FIGS. 25** and **26**. This may be utilized to form a cavity with side walls **2340** around the periphery of the button package **2300**. The cavity may then be further filled with a liquid resin of the type deposited in the processes described in regard to **FIGS. 25** and **26** to fill the cavity with the dielectric material **2302**.

[00138] **FIG. 24** illustrates another example button arrangement package formed similarly to the one illustrated in **FIG. 21** with the exception of the dielectric layer **2102** forming a layer **2450** that also includes or is mixed with or has deposited on top a suitable adhesive **2450** to allow for the placement of another dielectric layer **2460** formed from, e.g., corundum, otherwise known as  $\alpha$  aluminum oxide (" $\alpha$ Al<sub>2</sub>O<sub>3</sub>"), with the  $\alpha$  representing trace amounts, typically contributing to color, and also familiarly known as sapphires and rubies. Such material can be easily deposited in thin layers by thin film deposition processes known in the art. This dielectric layer can be extremely sturdy and dielectric in effect, while very thin at the same time. It will be understood by those skilled in the art that such thin film deposition may eliminate the need for some or all of the adhesive layer **2450**. It will be understood that the high dielectric constant material plate, which may be attached with the thin layer of adhesives **2450** after core button assembly **2100** construction, may also be formed by thin slices of crystalline forms of  $\alpha$ Al<sub>2</sub>O<sub>3</sub> (corundum). Such a dielectric layer, whether thin film deposited or placed as a slice(s) may be on the order of 100  $\mu$ m in thickness. Also possible is deposition through the extrusion of a thin plastic plate with interspersed high dielectric constant materials.

[00139] FIG. 27 illustrates an example of a button arrangement package 2700 wherein the dielectric material 2702 is added to the injection molding or like process when the further filler material 2730 is formed around the extension of the flex tape 2704 and copper metallization layer 2720. Alternatively the dielectric material 2702 covering the extension of the flex tape 2704 may be added and shaped after the addition of the additional filler material 2730. As an example, a molding with a resin material that is pre-composited with the high dielectric constant materials may be utilized after the molding extending the filler material 2730 as discussed above in regard to FIGS. 21-24 or as a substitute for the step of depositing the resin as described in regard to FIGS. 25 and 26.

[00140] The aspects of the disclosed subject matter as described thus far can thus be fabricated in large volume for the consumer market. As an example of process flow may consist of major steps, such as:

- start with a glass panel of desired thickness, e.g., of panel dimensions that are optimum for a given form factor.;
- deposit metal layer one, mask and etch, or screen-print a “patterned” metal layer one of transmitter electrodes/traces of a given width and pitch, or the like;
- deposit dielectric layer one, mask, and etch, or screen-print “patterned” isolation islands, or the like;
- deposit metal layer two, mask and etch, or screen-print a “patterned” metal layer two or receiver electrodes/traces of a given width and pitch, or the like;
- deposit dielectric layer two;
- planarize dielectric layer two to achieve flatness required for flip-chip;
- flip-chip bond the controller IC; and
- encapsulate the button with, e.g., a molded plastic enclosure.

[00141] A low-cost process flow may be as follows:

- start with a glass panel of a desired thickness, e.g., of panel dimensions that are selected for a given form factor;
- screen-print a “patterned” metal layer one formed of electrodes/traces;
- screen-print “patterned” isolation islands;

- screen-print a “patterned” metal layer two formed of perpendicular electrodes/traces;
- deposit dielectric layer two;
- planarize the dielectric layer two to achieve flatness required for flip-chip;
- etch or otherwise form appropriate vias;
- flip-chip bonding controller IC; and
- mold the plastic enclosure.

[00142] Another variation of a low cost process flow, which can, e.g., allow for integration of passive components into the confines of the structural arrangement, such as is shown by way of an example in **FIG. 20**, may be as follows:

- start with glass panel of desired thickness, e.g., of panel dimensions that are selected for a given form factor;
- laminate a thin copper foil to the glass panel, e.g., using a “high temperature” adhesive (ADH#1);
- pattern and etch the copper foil metal layer one;
- deposit dielectric layer one, mask and etch; e.g. to form the dielectric islands;
- screen-print a “patterned” metal layer two of electrodes/traces formed perpendicularly to the electrodes/traces of layer one;
- deposit dielectric layer two;
- planarize the dielectric layer two in order to achieve flatness required for flip-chip;
- bond the flip-chip controller IC;
- place passives as appropriate, e.g., pre-soldered passives onto the lead-frame;
- wire-bond I/O leads as appropriate to the lead-frame; and
- mold the plastic enclosure.

[00143] The ADH#1 material may include coloration and/or decorative additive(s) to enhance the cosmetic features of the finished product, e.g., as viewed through the topside glass. Most high dielectric constant materials are available in a powder form, and the powder can be mixed following conventional mixing techniques to disperse the respective powder(s) in various resins such as polyurethane or acrylic

resins. This can be done in a fashion similar to color pigments being dispersed in inks, e.g., by using an appropriate dispersant and/or by pre-treating the appropriate surface(s). The powders may also be combined into molten resin and/or repelletized for plastic molding or extruded to produce sheets of a desired thickness. Other high dielectric constant materials can be found in bulk crystal form which can then be cut and polished to be used as a plate, e.g., placed on top of a sensor.

[00144] FIG. 16 illustrates a cross sectional schematic view of a sensor electrode/trace arrangement 1600 as a variation of FIG. 13A. In FIG. 16 the transmitter electrodes/traces 1620 may be formed with intermediate openings 1650, through which the orthogonal receiver electrodes/traces 1640 may pass, with the openings 1650 and receiver electrodes/traces 1640, and portions of the transmitter electrodes/traces 1620 covered by dielectric islands 1652 also along the extension of the electrodes/traces 1620. The respective transmitter electrodes/traces 1620 may be bridged by jumpers 1630, which may be made of silver and may, in turn, be covered with additional dielectric islands 1610. The sensor controller IC 1616 may be mounted in a flip chip fashion by bumps 1602 which may be connected to, on the one hand, a metal lead 1604 from the transmitter electrode/trace 1620 to the sensor controller IC 1616 and, on the other hand, by a metal lead 1606, to a passive 1670 separated from the respective transmitter electrode/trace 1620 by dielectric 1660. The entire structure can be formed on the glass touch screen layer display glass 1600. According to aspects of embodiments of the disclosed subject matter, as noted above, a round area sensor on glass, e.g., with an 8mm or 9mm diameter and a 0.6mm or 0.7mm thickness is possible, integrating a system in plastic (“SIP”) module.

[00145] A chip on glass (“COG”) package lead frame according to aspects of the disclosed subject matter may have several options such as allowing for contact pads to be placed around the side of the button package. Alternatively, the contact pads may be placed at the bottom of the button, with the top formed by glass or other suitable transparent plastic materials such as epoxies and wherein the glass may also encapsulate the sensor IC and connections, such as wire bond connections to the bottom of the button, e.g., through connectors formed in vias.

[00146] Another COG arrangement may include a glass bottom substrate with a sensor controller IC 1616 connected to the glass through flip chip bumps which may be encapsulated in an ACF or non-conductive connective film (“NCF”). The glass may also be connected to a flex cable which may have transmitter and receiver

electrode(s)/trace(s) formed on opposite sides thereof and connected to the glass by ACF bonding.

[00147] A system in a package (“SIP”) *1900*, as illustrated in **FIGS. 19A** and **19B** may be formed with passive components *1940* in the package *1900*. The system *1900* may have circular transmitter and or receiver electrodes *1904*, one of which is illustrated schematically in **FIGS. 19A** and **19B**. As can be seen by way of example in **FIG. 19B**, the electrode *1904* may be connected to the glass *1902* by ACF bonding *1910* and to the passives *1940* by conductive bonding *1930*. The sensor IC may be connected to the glass *1902* by bumps *1922* and bonding pads *1920* surrounded by ACF/NCF bonding *1924*. The entire system may be encapsulated by molding/filling plastic *1960*. This can provide for a large sensor area with minimum border area and no need for a printed circuit board arrangement, low cost bonding and a compact form. Such a button can be round in form, be attached by a lead frame and have capacitors or other passives *1950* in the button, and may, as noted above, include wire bonding. Such may be seen by way of example in **FIG. 20** where the electrode *2004* may be connected to the glass *2002* by wire bonding pads *2080*, *2082* and connecting wire bonds *2086*.

[00148] Addition of a sensor signal boosting structure by mixing in high dielectric constant materials to sensor packaging or coating materials can result in signal to noise ratio improvement and thus improvement of overall signal strength can be accomplished by, e.g., diffusing higher dielectric particles in coatings/protective layers/moldings and the like that are intermediate a finger of a user and the traces forming the capacitive sensor sensing elements. Thus, within a chip on film (COF) structure or a ball grid array (BGA) sensor package, both of which may be utilized for 1D linear array capacitive gap sensors and 2D sensor element grid arrays, swiped and placement, such packaged COF or BGA sensors can have components which can be integrated into, e.g., user mobile devices, such as cell phones, smart phones, pads, tablets, personal digital assistants (PDAs) and other applicable consumer electronic devices can be fabricated using multiple layers of protective dielectric material, such as molding or epoxy filling, or stacking multiple layers of hard materials for the desired hardness, durability and possibly other aesthetics, such as if the materials are transparent or pigmented or the like.

[00149] In passive capacitive biometric sensors, e.g., a fingerprint sensor, a received sensor signal can be affected by any such materials that are incorporated into

any protective/decorative coating. Such a coating could form part of an insulating layer and/or a molded structure, e.g., as part of a housing or package for the sensor sensing elements and perhaps electronics, etc. When such material is situated between the sensor elements, such as may form a 1D linear array capacitive gap sensor array or a 2D grid array, swiped or placement sensor, and the finger of a user during the operation of the sensor, i.e., as the finger is placed on the sensor array or swiped over the sensor array, in most cases, the thicker the topping materials are, the lower the sensor output signal level. On the other hand, for mechanical durability and other reasons, such as electrical isolation and the like, thick and hard materials may be desirable to be placed over the sensor sensing elements. However, the thickness is, as noted, limited due to signal degradation. According to aspects of the disclosed subject matter such shortcomings in the art are at least alleviated. The sensor sensing elements, i.e., electrodes/traces may be formed on an a flexible tape layer adjacent the harder coating material separated from the user finger by the harder coating material.

**[00150]** The received signal across a capacitive gap in a 1D sensor or at the receiver sensor sensing element(s) in a 2D grid array sensor at a given image pixel sensing location on the grid array is largely effected by the capacitance between the user's finger and the receiver element. This is in turn affected by the type and thickness of the material between the finger and the receiver sensing element, or in some embodiments the sensing transmitter element. The conductive sensor sensing elements, e.g., made of copper (Cu) could be formed under the flex layer, and thus the dielectric effect of the flex layer would need to be factored in as well.

**[00151]** According to aspects of embodiments of the disclosed subject matter, the signal to noise ratio may be improved, e.g., by diffusing higher dielectric constant material(s) into the protective coating/molding/filling dielectric material so as to, e.g., allow more field flux to reach the finger of the user. That is the capacitive dielectric rating can be decreased so more electric field reaches the finger and the impact of the capacitance of the finger on the received field (i.e., whether there is a ridge or valley at the particular pixel location can be more easily detected for an given applied signal strength transmitted from the sensor transmitter element(s) in effect. Lower dielectric number materials such as a vacuum (the lack of any material), air, Teflon®, polyimide, silicon dioxide have low dielectric constant numbers (the ratio of the permissivity of the material in relation to air). These generally form better insulators between the conductive plates of a capacitor, with the lower numbers forming

capacitors with higher capacitive impedance. Higher dielectric constant materials such as TiO<sub>2</sub>, 86-173, strontium titanium oxide (STO), SrTiO<sub>3</sub>, 310 and barium strontium titanium oxide (BSTO), BaSrTiO<sub>3</sub>, 500 can be used as suitable diffusants/dispersants. As the coating/protective/insulative layer becomes thicker, more diffusant/dispersant of the type denoted may be utilized to maintain/increase signal to noise ratio.

**[00152]** 3M™ Scotch-Weld™ sold under the name epoxy potting compound, DP270 is a rigid, two-part epoxy adhesive potting compound, with a 1:1 mix ratio, 70 minute work life and reaches handling strength from a relatively viscous initial state in approximately 3 hours. The material is non-corrosive to copper and finds applications in, e.g., solar energy, wind energy, composites and electronics applications for bonding, gluing, joining, attaching, assembling, encapsulating, potting and sealing. Such an adhesive may be used according to aspects of some embodiments of the disclosed subject matter.

**[00153]** Ferro Electronic Material Systems offers a wide variety of ceramic materials to improve the performance of organic compounds used in a broad range of applications. These additives can enhance conductivity, improve high-frequency performance, alter permittivity, modify sealing characteristics, improve flame resistance, improve moisture resistance and provide many other benefits. Such Ferro additives are examples of filled polymers. The table below lists specific products and applications. Additives can include: Barium Strontium Titanate, Strontium Titanate, Titanium Dioxide ;Barium Titanate; Bismuth Trioxide; Barium Zirconate; Zirconium Oxide; Ceramic Powders. Each application can require specific physical characteristics and variables can be adjusted to meet the needs for filled polymers applications. For example, varying the amount of barium and strontium in an additive can shift the Curie Point of the composite material, e.g., to enhance performance over a specific temperature range. Table I discloses possible materials for use as high dielectric additives.

TABLE I

Ceramic Powders	Typical Application	Particle Size Dist. ( $\mu\text{m}$ )			Surface Area ( $\text{m}^2/\text{g}$ )
		D90	D50	D10	
104-2 Zirconium Oxide I	Plastic filler	3.3	0.8	0.34	10.51
119 Barium Zirconate	Plastic seals and molding	3.1	1.0	0.61	4.16
203-4 Titanium Dioxide	Filled polymers to reduce dielectric constant and promote high frequency performance	1.7	1.1	0.65	4.7
Ticon <sup>®</sup> HG Titanium Dioxide	Filled polymers to reduce dielectric constant and promote high frequency performance	4.5	3.0	1.5	2.3
Ticon <sup>®</sup> CG Titanium Dioxide	Filled polymers to reduce dielectric constant and promote high frequency performance	7.2	4.0	1.9	–
217 Calcium Titanate	Polymer antennas and other telecom applications	4.2	1.6	0.75	4.55
218 Strontium Titanate	Filled polymers to promote high frequency performance; toners and anticounterfeiting applications	4.6	2.0	0.93	1.81
Ticon <sup>®</sup> 55 Strontium Titanate	Filled polymers to promote high frequency performance	2.9	1.1	0.5	4.3
219-6A Barium Titanate	Dielectric constant booster for filled circuit boards, electroluminescent lights and other filled applications	2.1	1.3	0.8	2.1
Ticon <sup>®</sup> C Barium Titanate	Dielectric constant booster in filled circuit boards and other filled applications	3.8	1.5	0.6	2.4
Ticon <sup>®</sup> HPB Barium Titanate	Electroluminescent lighting	2.1	1.0	0.4	3.2
BST Barium Strontium Titanate	Filled polymers to promote targeted high-frequency performance				
320A Bismuth Trioxide	Density modifier for plastics	16	6.1	1.5	0.2-0.5
AD143N Ceramic Powder	Dielectric constant booster in filled circuit boards and other filled applications	1.9	0.9	0.5	3

[00154] According to aspects of embodiments of the disclosed subject matter suitable high dielectric constant materials can be used to incorporate into selected resins for sensor packaging. For the ease of dispersions, sub-micron or even finer nanoparticles can provide excellent candidates to fill the resins. One can determine

the mass loading of high dielectric constant materials, where the mass loading % is determined based on viscosity requirements and molding techniques. If additional steps such as polishing or grinding of the signal boosting structure (SBS) are required, consideration of such subsequent process steps can be taken. There are many ways to create the SBS, after complete diffusion of high dielectric constant materials: 1) coating/printing of mixed liquid resin, 2) injection molding, 3) cavity filling, 4) plate attachment, etc. These steps could be considered and selected, based on sensor design and integration needs. A uniformly thick SBS may be required or at ; least preferred across the full length of the sensor and to be able to reproduce consistent thickness from one packaged sensor to another. Additional layers can be incorporated on top of the SBS for aesthetic purposes. The final layers should not significantly alter the sensor performance yet survive through a series of reliability tests which are defined by customers.

[00155] FIG. 22 illustrates schematically an arrangement 2250 wherein a sensor controller IC chip can be connected to a substrate 2210. This may then be connected to another module by lead lines 2212 formed on the substrate 2210. The IC may be connected to the substrate 2210 by bonding pads 2220, which may, in turn, be connected to primary and secondary receiver traces 2202, 2204 and transmitter traces at the locations 2220 of the bonding pads, since the electrical traces as illustrated in FIG. 22 are on the same side of the substrate 2210 as the IC mounting pads 2220 and, therefore, the IC itself.

[00156] Methods for manufacturing any of the various devices disclosed can be summarized as follows:

- Select suitable high dielectric constant materials to incorporate into selected resins for sensor packaging. For the ease of dispersions, sub-micron or even finer nanoparticles are the excellent candidates to fill the resins.
- Determine mass loading of high dielectric constant materials. Mass loading % is determined based on viscosity requirements and molding techniques. If additional steps such as polishing or grinding of the signal boosting structure (SBS) are required, consideration of such subsequent process steps must be taken.

- There are many ways to create the SBS, after complete diffusion of high dielectric constant materials as shown, e.g., in FIGS. 19-24: 1) coating/printing of mixed liquid resin, 2) injection molding, 3) cavity filling, 4) plate attachment, etc. These steps could be considered and selected, based on sensor design and integration needs. It is critical to have a uniformly thick SBS across the full length of the sensor and to be able to reproduce consistent thickness from one packaged sensor to another.
- Additional layers can be incorporated on top of the SBS for aesthetic purposes. The final layers should not significantly alter the sensor performance yet survive through a series of reliability tests which are defined by customers.

**[00157]** It will be understood that a biometric object sensor button arrangement core and method of forming the same is disclosed which may comprise a flex material layer; a sensor controller IC mounted on one side of the flex material layer; a metallization layer comprising a plurality of sensor sensing element traces and controller IC input/output traces formed on at least one side of the flex material layer, each in electrical connection with controller IC; an encapsulation layer encapsulating the controller IC to one of the flex material layer and the metallization layer; and a protective layer covering one of the flex material layer and the metallization layer on a surface opposite from where the controller IC is mounted, comprising a dielectric material dispersed with at least one high dielectric material utilizing a dispersant. The biometric object sensor button may further comprise a fingerprint sensor button. The metallization layer may comprise a first metallization layer formed on a first surface of the flex material comprising the sensor sensing element traces and a second metallization layer formed on a second surface of the flex layer opposing the first surface of the flex layer and comprising at least some of the controller IC input output traces. The button arrangement core may further comprise an extension of the flex layer and the metallization layer extending from the encapsulation layer and a further encapsulation of the extension of the flex layer from the button arrangement core and the extension of the metallization layer from the button arrangement core to form a button arrangement package. A further encapsulation of the extension of the flex layer and a further deposition of dielectric material on the metallization layer may be

included to form a button arrangement package. The button arrangement core may further comprise an adhesive layer covering the one of the flex layer and the metallization layer and the extension of the encapsulation of the flex layer and the metallization layer; and a layer of dielectric material adhered to the adhesive layer, which may be corundum and may be deposited by thin film deposition or as a thin crystalline sheet(s). The method may comprise forming a flex material layer; mounting a sensor controller IC on one side of the flex material layer; forming a metallization layer comprising a plurality of sensor sensing element traces and controller IC input/output traces formed on at least one side of the flex material layer, each in electrical connection with controller IC; encapsulating the controller IC in an encapsulation layer formed on one of the flex material layer and the metallization layer; and forming a protective layer covering one of the flex material layer and the metallization layer on a surface opposite from where the controller IC is mounted, comprising a dielectric material dispersed with at least one high dielectric material utilizing a dispersant.

**[00158]** While preferred embodiments of the present invention have been shown and described herein, it will be obvious to those skilled in the art that such embodiments are provided by way of example only. Numerous variations, changes, and substitutions will now occur to those skilled in the art without departing from the invention. It should be understood that various alternatives to the embodiments of the invention described herein may be employed in practicing the invention. It is intended that the following claims define the scope of the invention and that methods and structures within the scope of these claims and their equivalents be covered thereby.

## CLAIMS

## WHAT IS CLAIMED IS:

1. A method of imaging a biometric object comprising:

utilizing a biometric image sensor, the biometric image sensor comprising:

a plurality of capacitive gap sensor electrode traces forming an array of biometric sensor imaging pixel locations within a biometric sensing area of the biometric image sensor,

at least one of the sensor electrode traces forming a drive signal transmitter electrode and at least one of the sensor electrode traces forming a resulting signal receiver electrode trace, the respective drive signal transmitter electrode and respective resulting signal receiver electrode trace being formed on one of a single side of a first substrate and an opposite side of the first substrate;

wherein a change in a resulting signal received by the at least one resulting signal receiver electrode trace is indicative of a biometric image characteristic at a respective pixel location in the array;

utilizing a controller contained in an integrated circuit mounted to a second substrate remote from the biometric sensing area and in electrical contact with the sensor electrode traces;

utilizing an intermediate logic circuit formed between the controller and the sensor electrode traces in the biometric sensing area, wherein the intermediate logic circuit is formed on at least one of the first substrate and a third substrate mounted to the first substrate,

the intermediate logic circuit configured to control an activation sequence for a subset of the plurality of the capacitive gap sensor array pixel locations in response to a single signal from the controller to the intermediate logic circuit.

2. The method of claim 1 wherein the first substrate and the second substrate comprise a single substrate.

3. The method of claim 2 wherein the single substrate comprises one of a flexible dielectric and a glass substrate.

4. The method of claim 1 wherein the single signal from the controller comprises a first coded control signal, and in response to receiving the single signal the intermediate logic circuit is configured to individually address a subset of the at least one resulting signal receiver electrode traces and communicatively couple the respective resulting signal receiver electrode trace to an first input of the controller.

5. The method of claim 1 wherein the single signal from the controller comprises a second coded control signal causing the intermediate logic circuit to both individually address a third subset of the at least one resulting signal receiver electrode traces and provide a received resulting signal to a first output of the intermediate logic circuit and (2) individually address a fourth subset of the at least one resulting signal receiver electrode traces and connect the respective resulting signal receiver electrode traces to a second output of the intermediate logic circuit.

6. The method of claim 5 wherein the first output comprises a first input to a differential amplifier and the second output comprises a second input to the differential amplifier.

7. The method of claim 5 wherein the second coded control signal comprises an output of a shift register set by the controller, communicatively coupling the control logic routing respective individual resulting signal receiver electrode traces to the first output or second output.

8. The method of claim 7 wherein the intermediate logic circuit comprises logic circuit transistor switches formed on at least one of the first substrate and the third substrate.

9. The method of claim 8 wherein the logic circuit transistor switches comprise thin film transistors.

10. The method of claim 1 wherein the intermediate logic circuit further comprises a thin film transistor amplifier formed on one of the first substrate and the

third substrate between a resulting signal electrode trace and the intermediate logic circuit.

11. A biometric object imaging sensor comprising:

a plurality of capacitive gap sensor electrode traces formed on one of a single side of a first substrate and an opposite side of the first substrate; the plurality of sensor electrode traces forming an array of biometric sensor imaging pixel locations within a biometric sensing area of the biometric image sensor,

wherein at least one of the sensor electrode traces comprises a transmitter electrode trace and at least one of the sensor electrode traces comprises a receiver electrode trace, wherein a change in a resulting signal received by the at least one receiver electrode trace is indicative of a biometric image characteristic at the respective pixel location in the array, the respective drive signal transmitter electrode trace and respective drive signal receiver electrode trace being;

a controller contained in an integrated circuit mounted to a second substrate remote from the biometric sensing area and in electrical contact with the sensor electrode traces;

an intermediate logic circuit between the controller and the sensor electrode traces in the biometric sensing area, formed on at least one of the first substrate a third substrate coupled to the first substrate, the intermediate logic circuit configured to control an activation sequence for a subset of the plurality of the capacitive gap sensor array pixel locations in response to a single signal from the controller to the intermediate logic circuit.

12. The biometric object imaging sensor of claim **11** wherein the first substrate and the second substrate comprise a single substrate.

13. The biometric object imaging sensor of claim **12** wherein the single substrate comprises one of a flexible dielectric and a glass substrate.

14. The biometric object imaging sensor of claim **11** wherein the single signal from the controller comprises a first coded control signal causing the intermediate logic circuit to one of (1) individually address a first subset of the at least one transmitter electrode traces and provide a drive signal to the respective transmitter

electrode traces and (2) individually address a second subset of the receiver electrode traces and connect the receiver electrodes trace to an output of the biometric imaging sensor.

15. The biometric object imaging sensor of claim **11** wherein the single signal from the controller comprises a second coded control signal causing the intermediate logic circuit to both individually address a third subset of the at least one receiver electrode traces and provide a received resulting signal to a first output of the intermediate logic circuit and (2) individually address a fourth subset of the at least one receiver electrode traces and provide the received resulting signal to a second output of the intermediate logic circuit.

16. The biometric object imaging sensor of claim **15** wherein the first output comprises a first input to a differential amplifier and the second output comprises a second input to the differential amplifier.

17. The biometric object imaging sensor of claim **15** wherein the second coded control signal comprises an output of a shift register set by the controller, connected to control logic routing respective receiver electrode traces to the respective first output or second output.

18. The biometric object imaging sensor of claim **17** wherein the intermediate logic circuit comprises logic circuit transistor switches formed on at least one of the first substrate and the third substrate.

19. The biometric object imaging sensor of claim **18** wherein the logic circuit transistor switches comprise thin film transistors formed on the one of the first substrate and the third substrate.

20. The biometric object imaging sensor of claim **10** further comprising the intermediate logic circuit comprising a thin film transistor amplifier formed on one of the first substrate and the third substrate between a respective receiver electrode trace and the intermediate logic circuit.

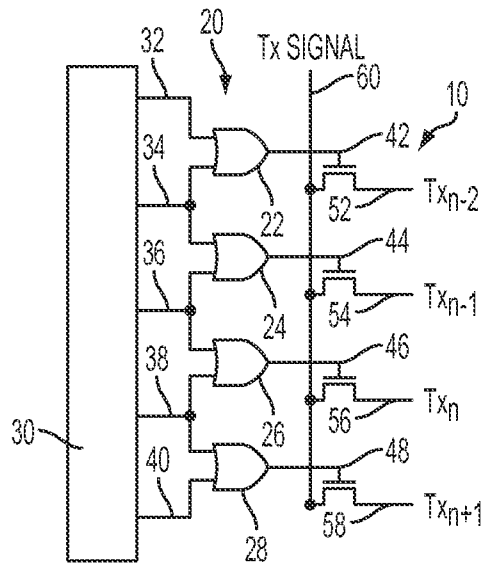

FIG. 1

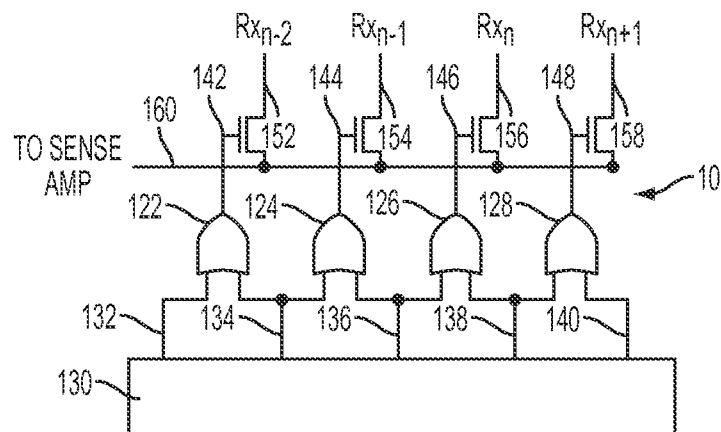

FIG. 2A

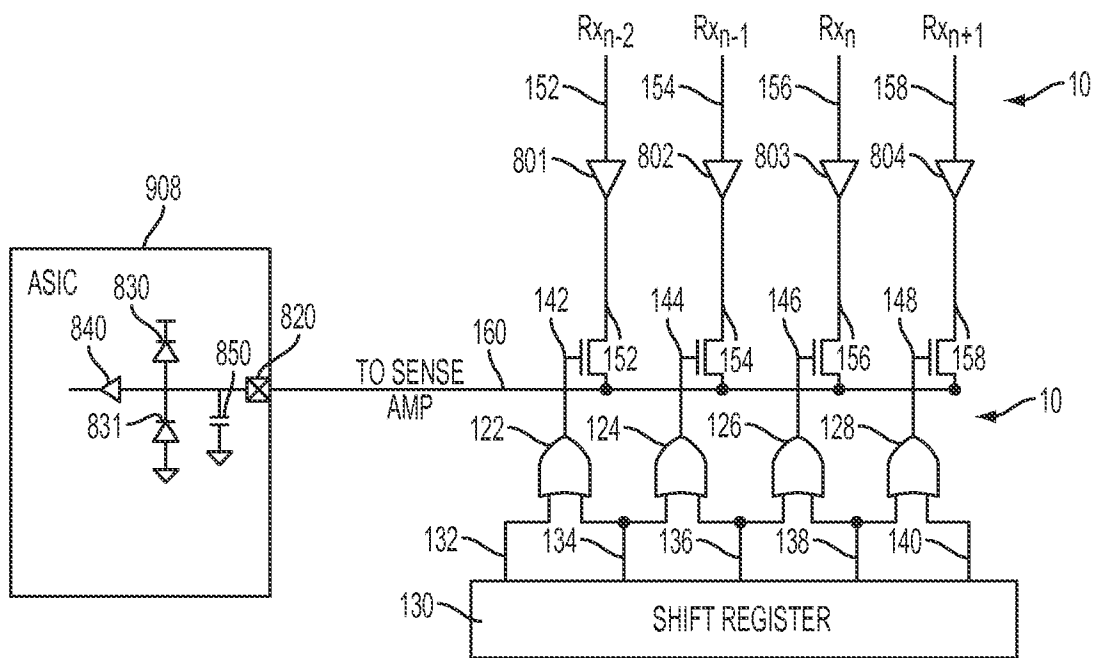

FIG. 2B

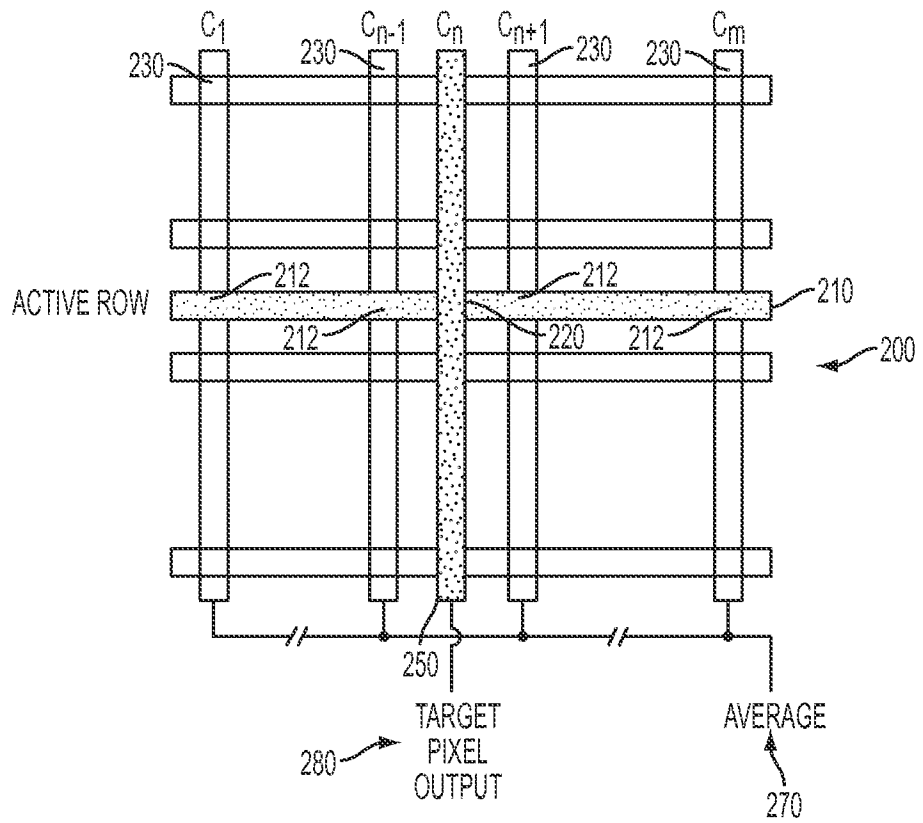

FIG. 3

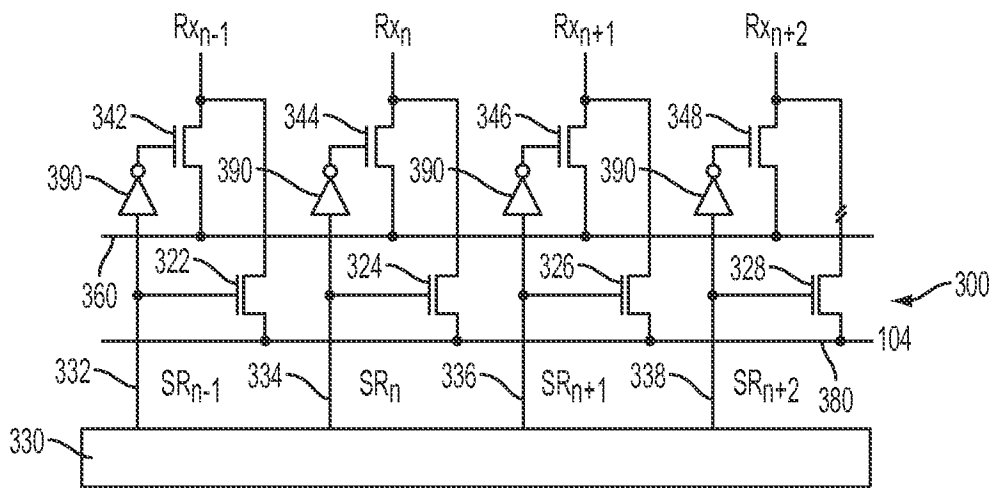

FIG. 4A



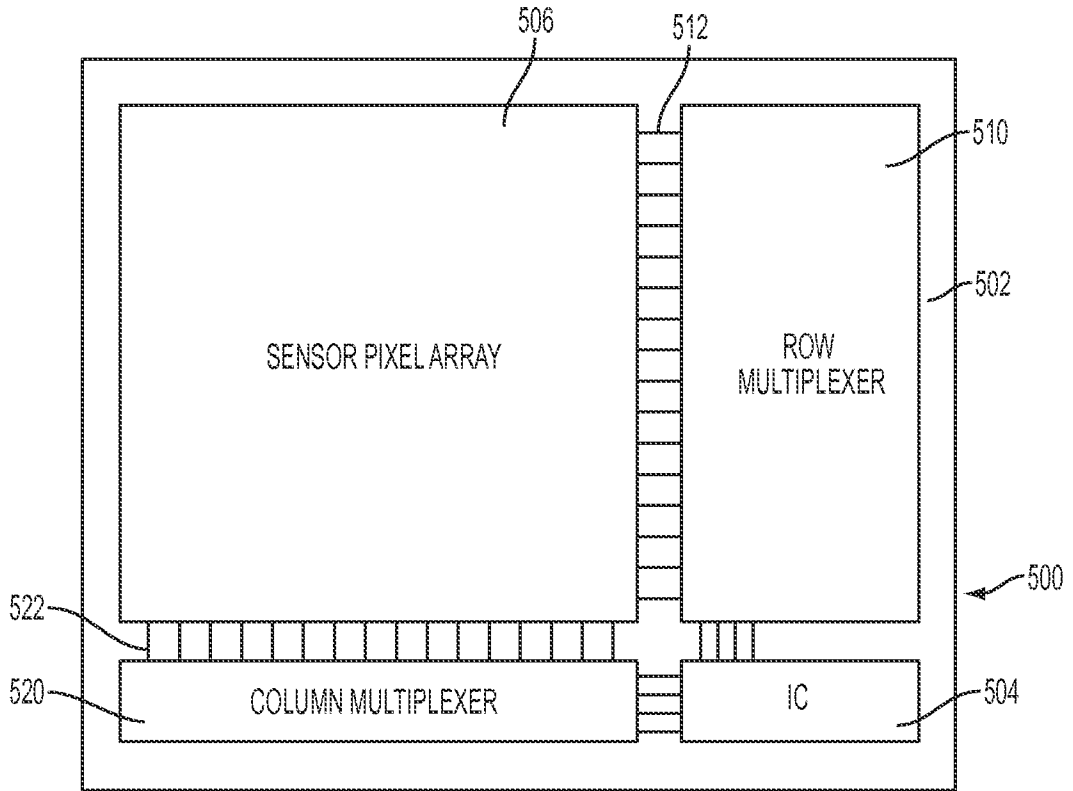

FIG. 5

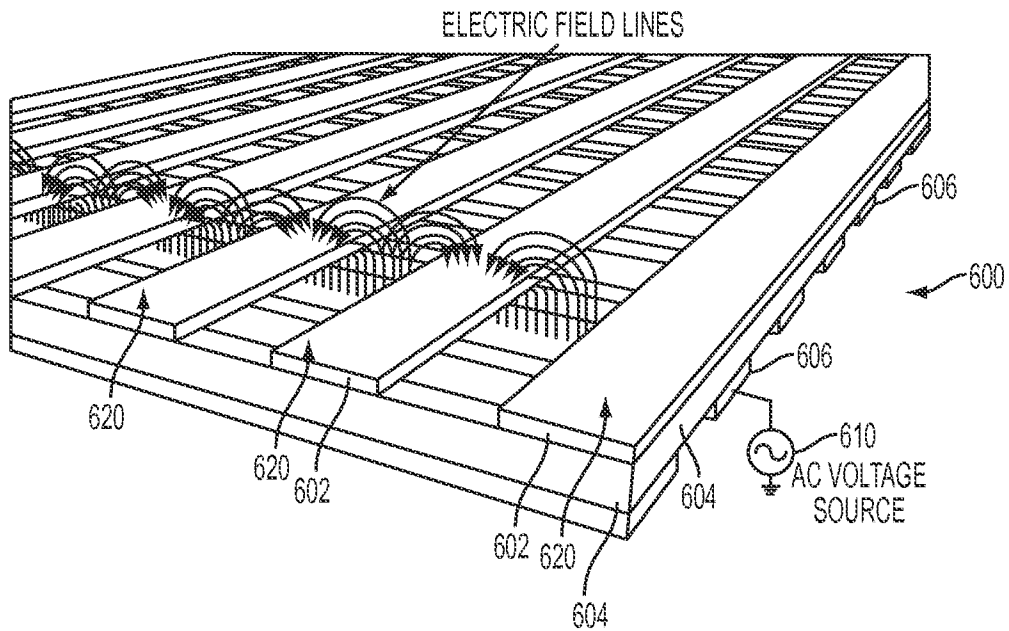

FIG. 6

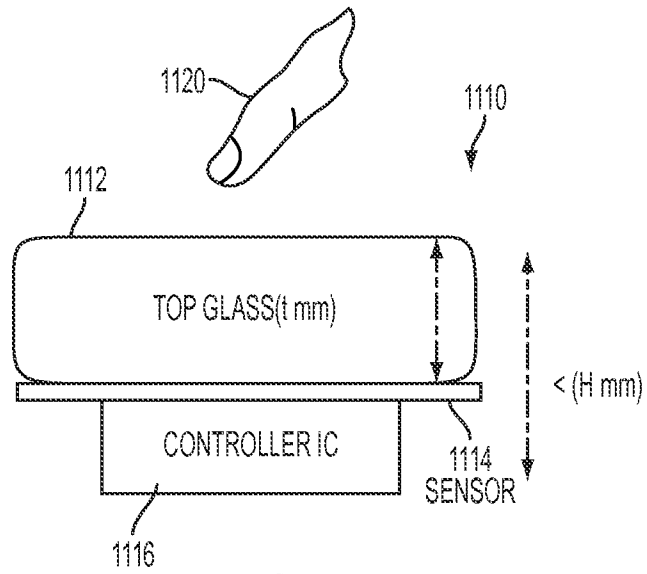

FIG. 7

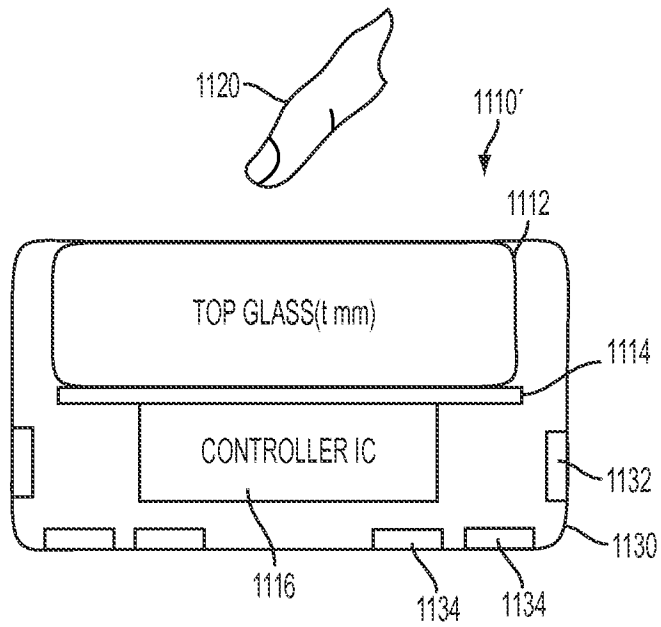

FIG. 8

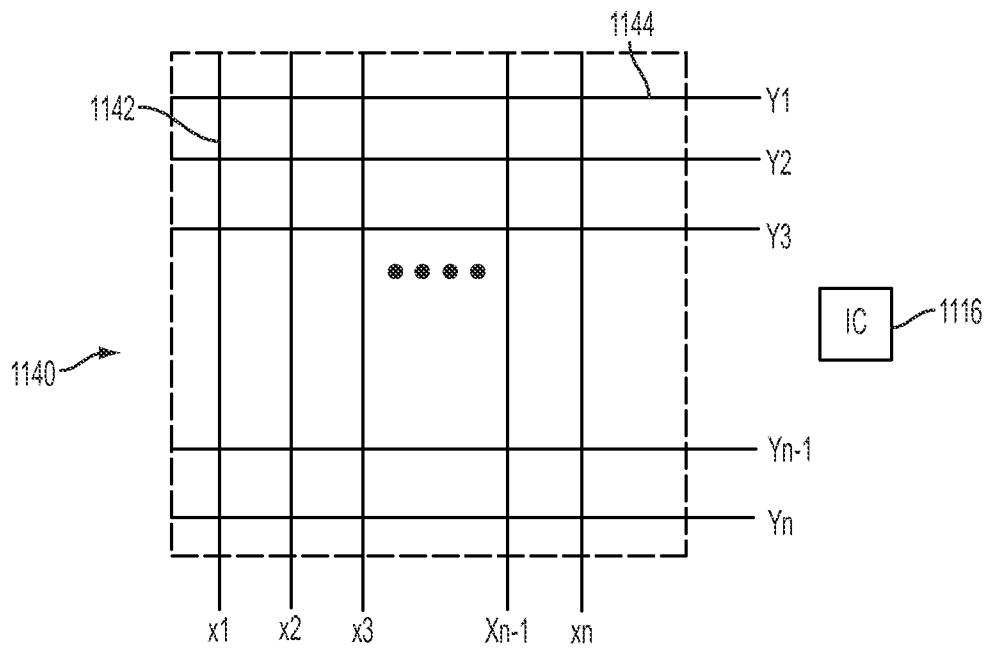

FIG. 9

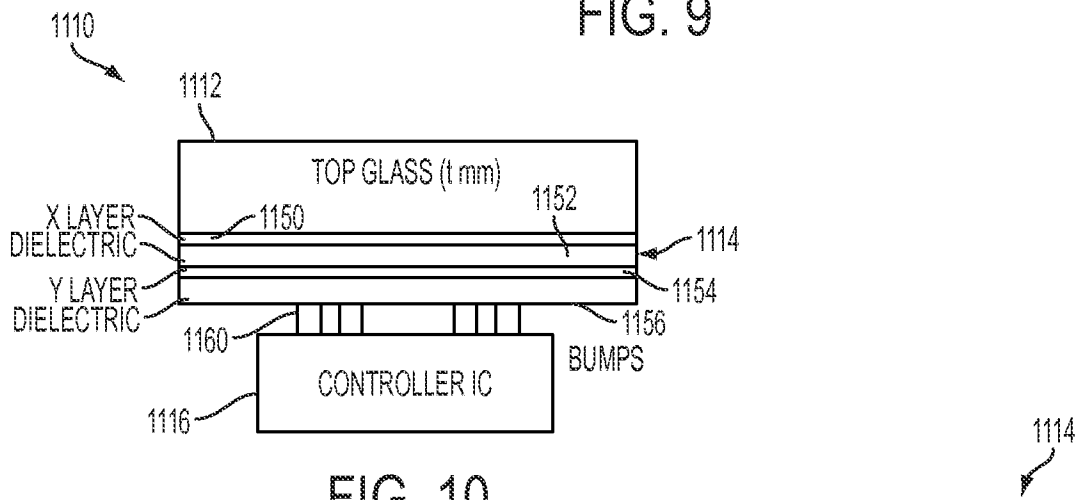

FIG. 10

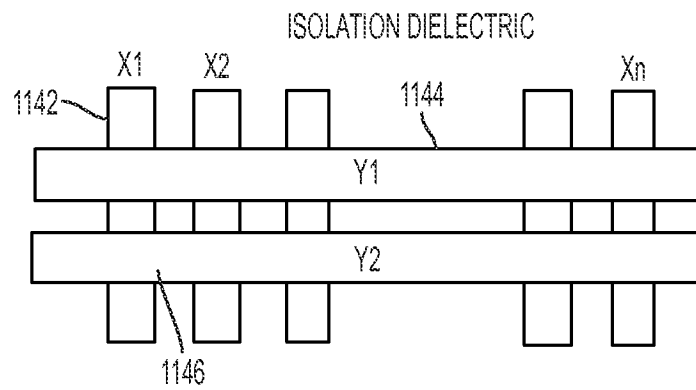

FIG. 11

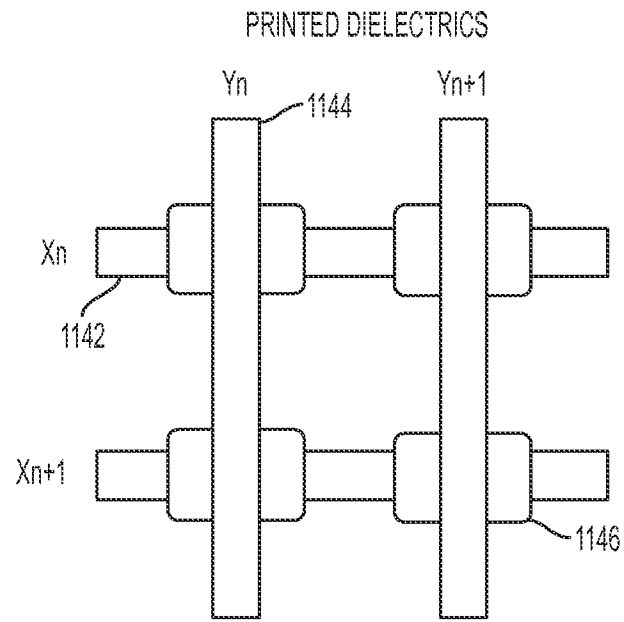

FIG. 12A

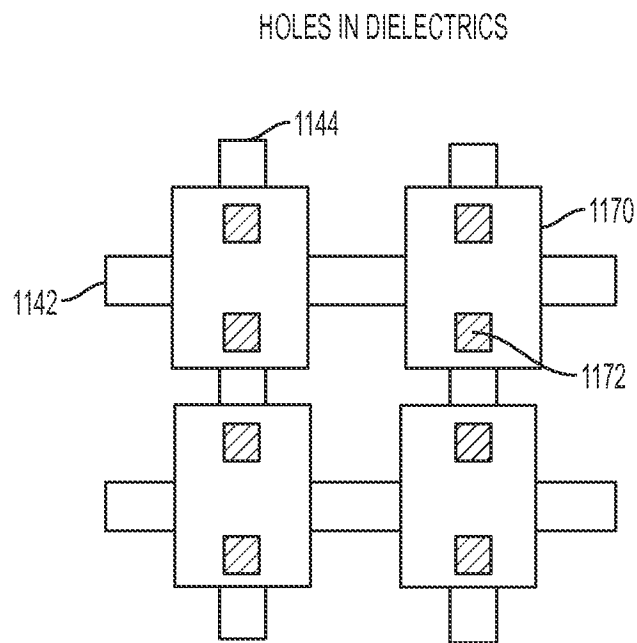

FIG. 12B

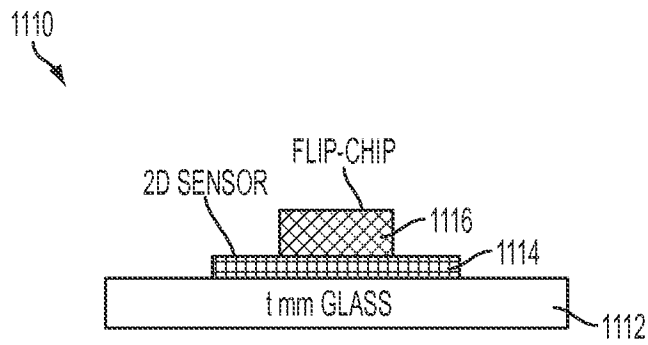

FIG. 13A

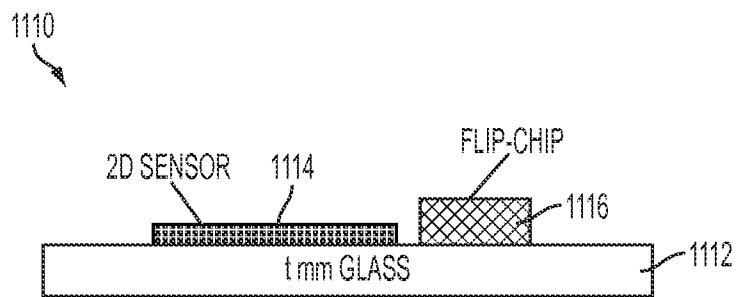

FIG. 13B

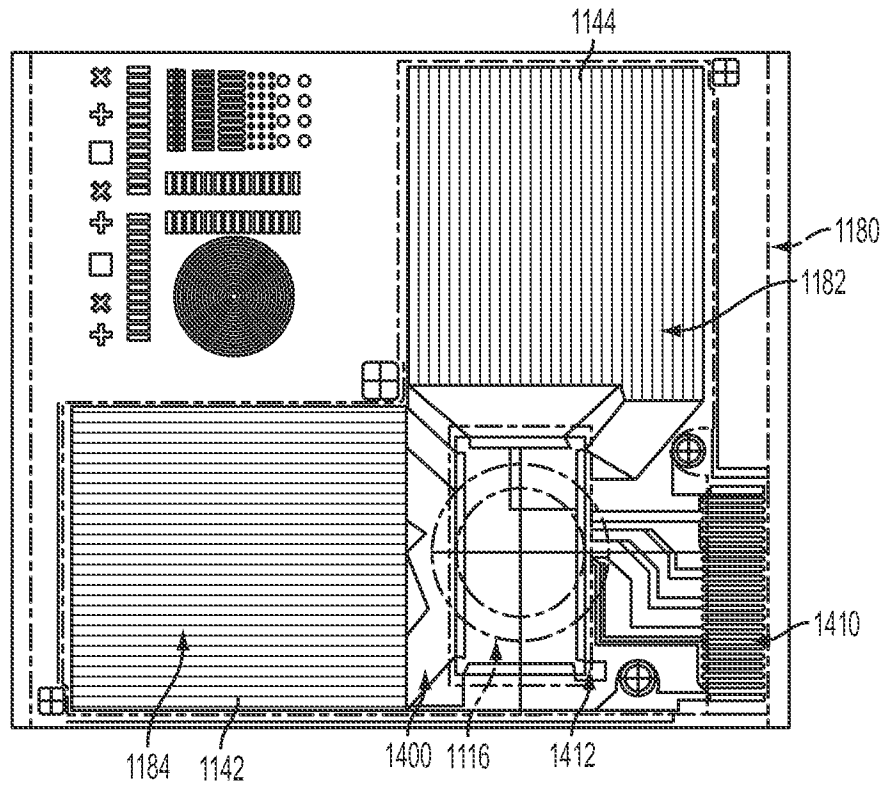

FIG. 14A

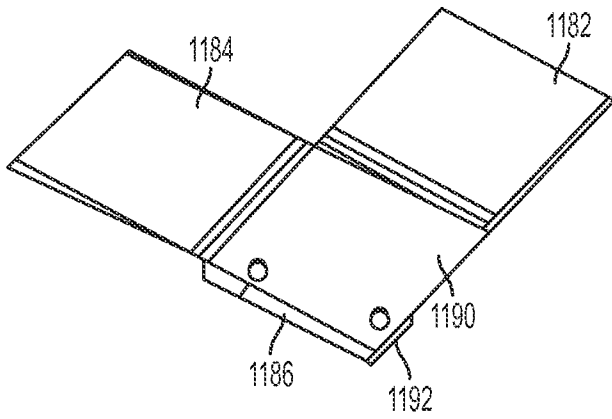

FIG. 14B (1)

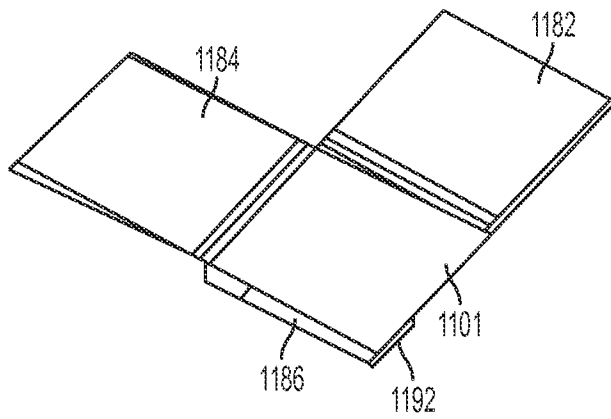

FIG. 14B (2)

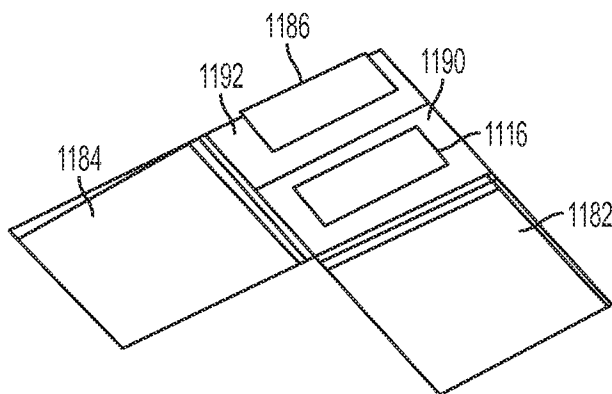

FIG. 14B (3)

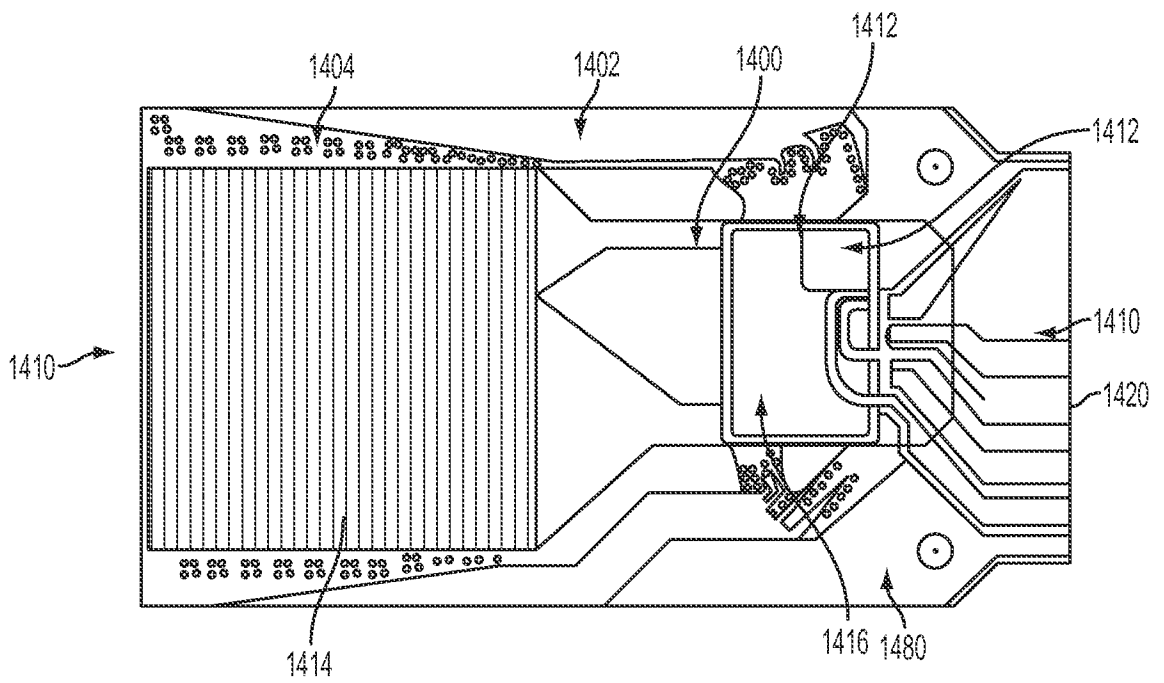

FIG. 14C

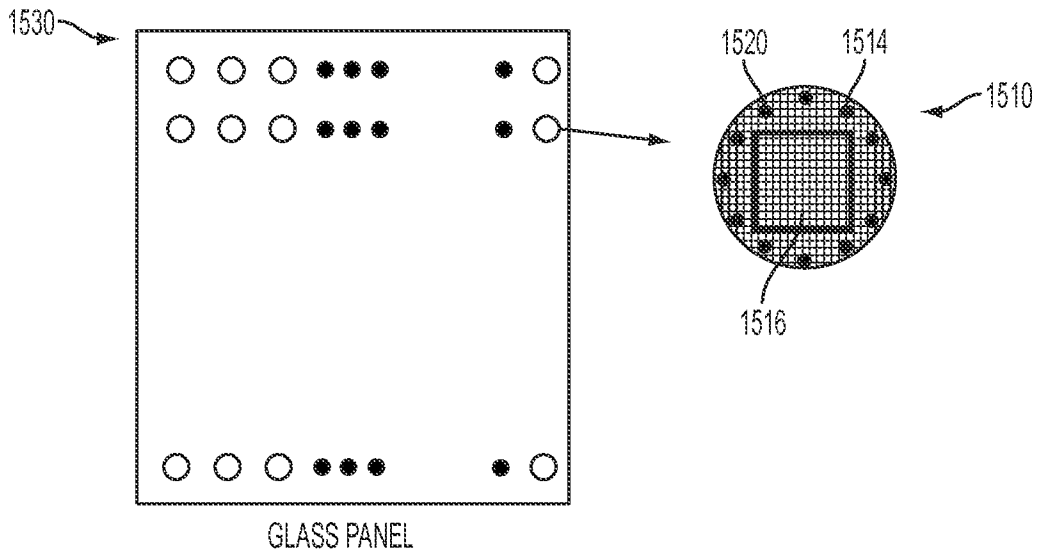

FIG. 15

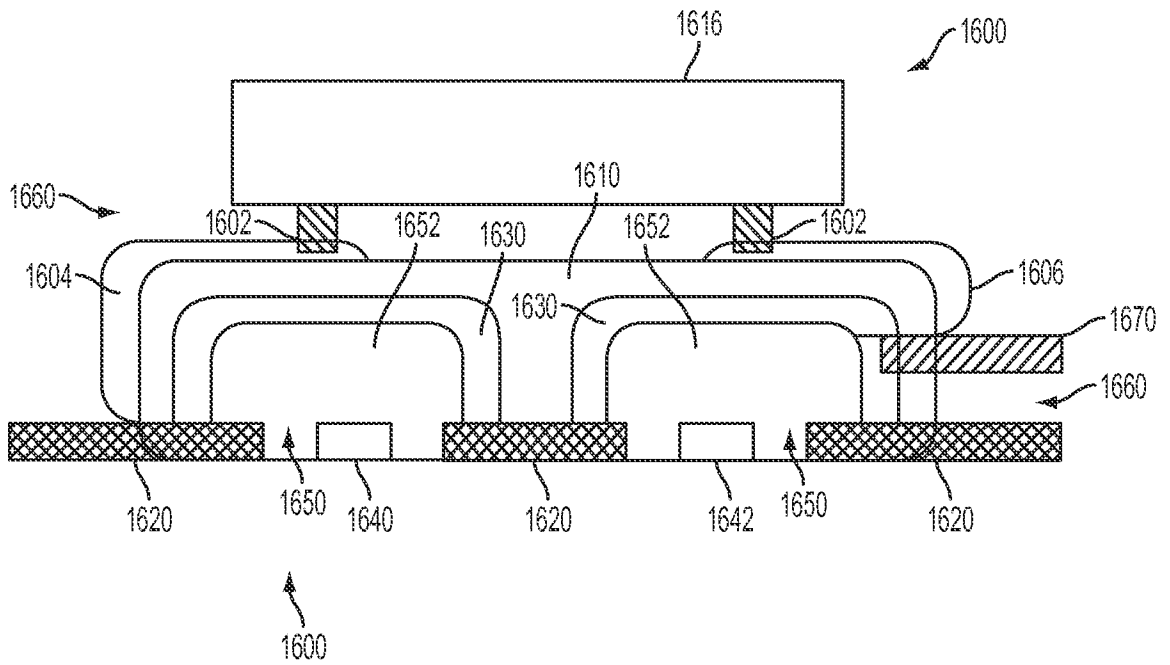

FIG. 16

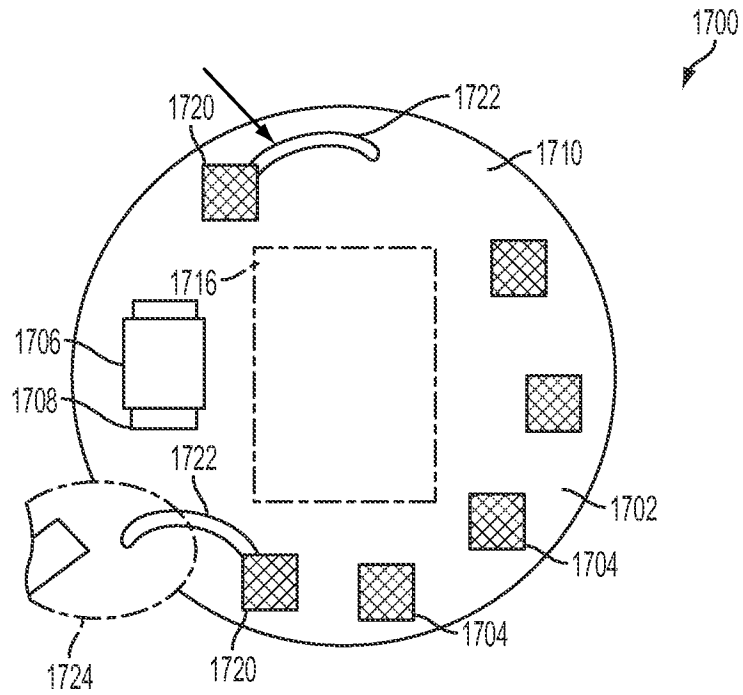

FIG. 17

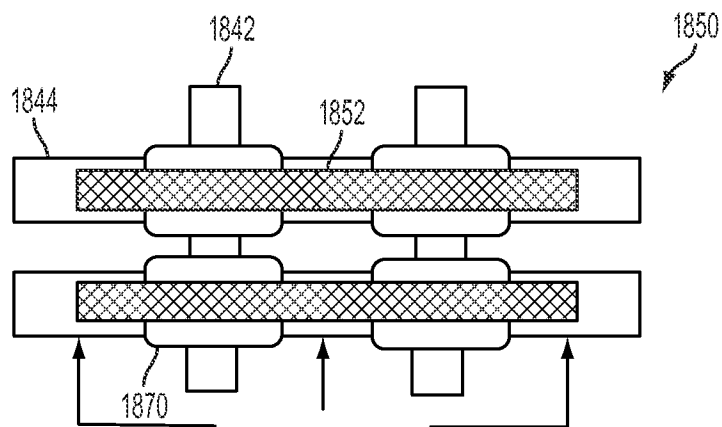

FIG. 18

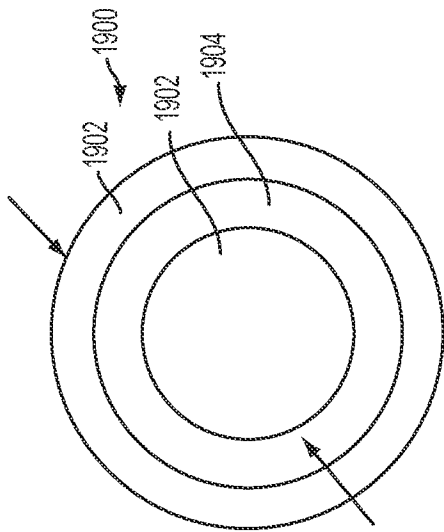

FIG. 19A

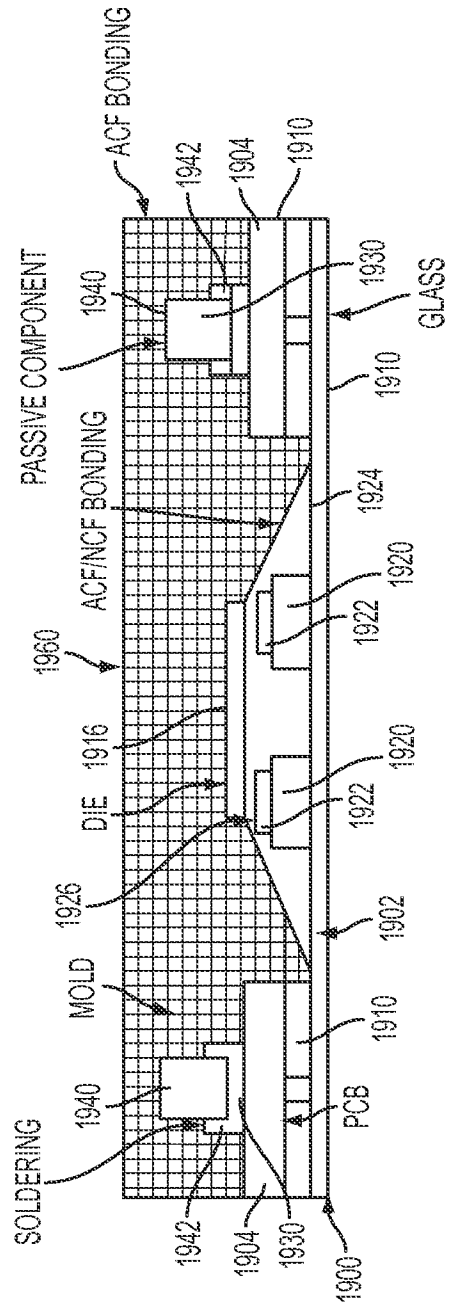

FIG. 19B



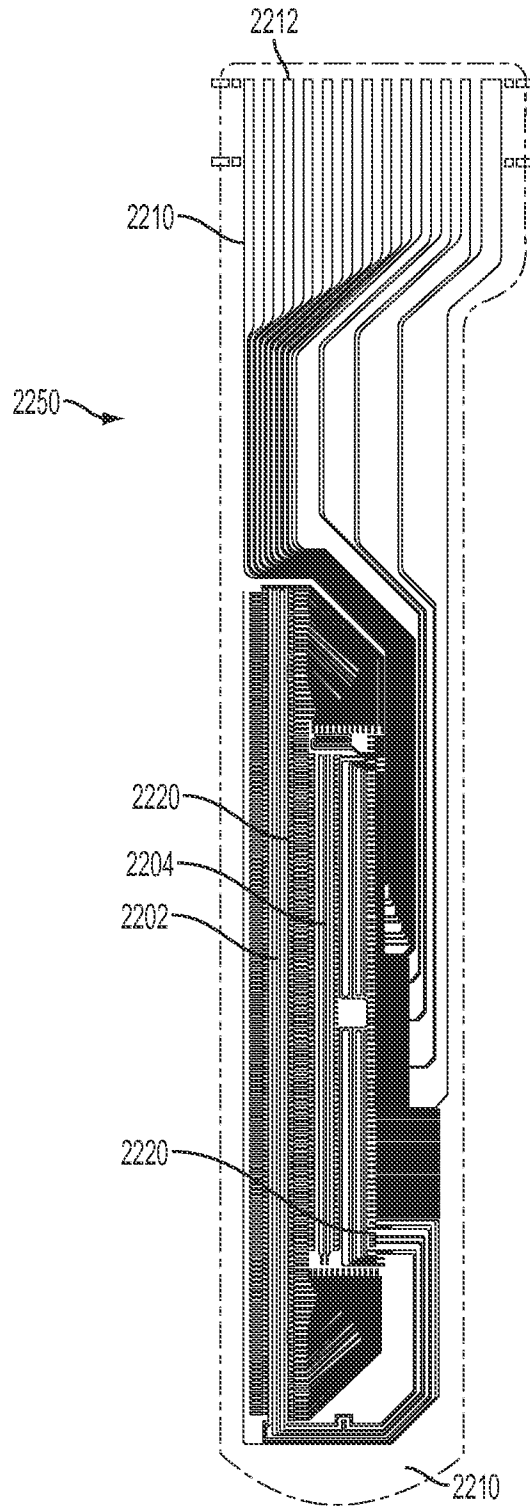

FIG. 22

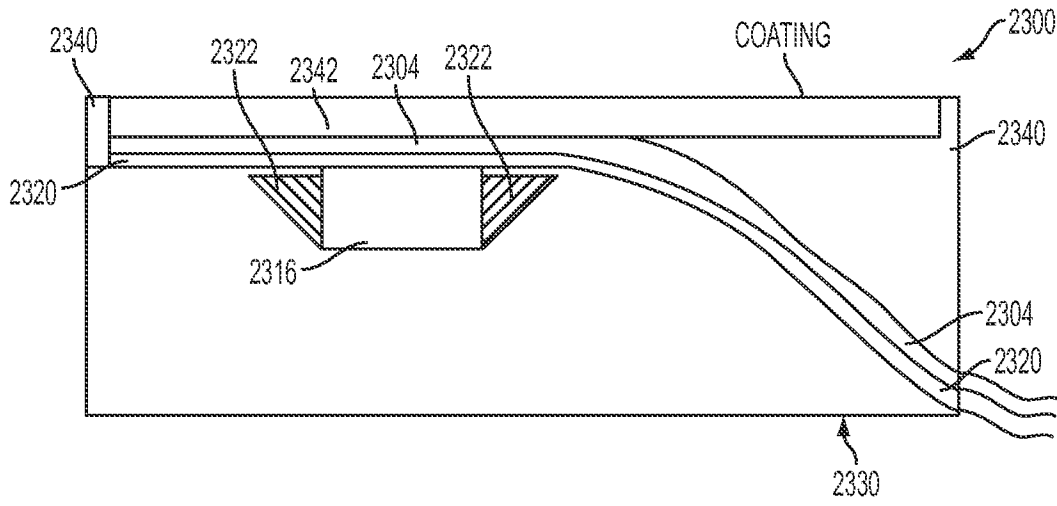

FIG. 23

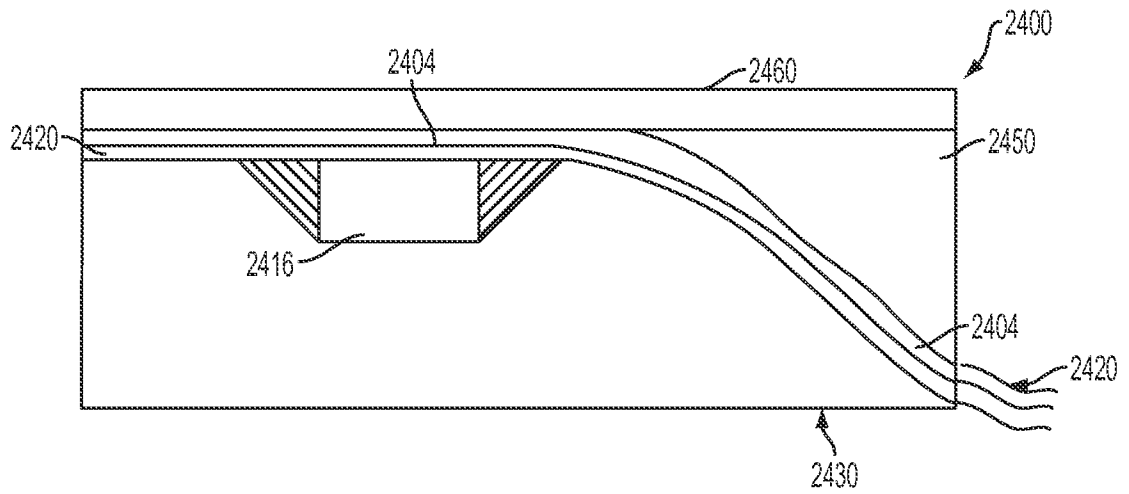

FIG. 24

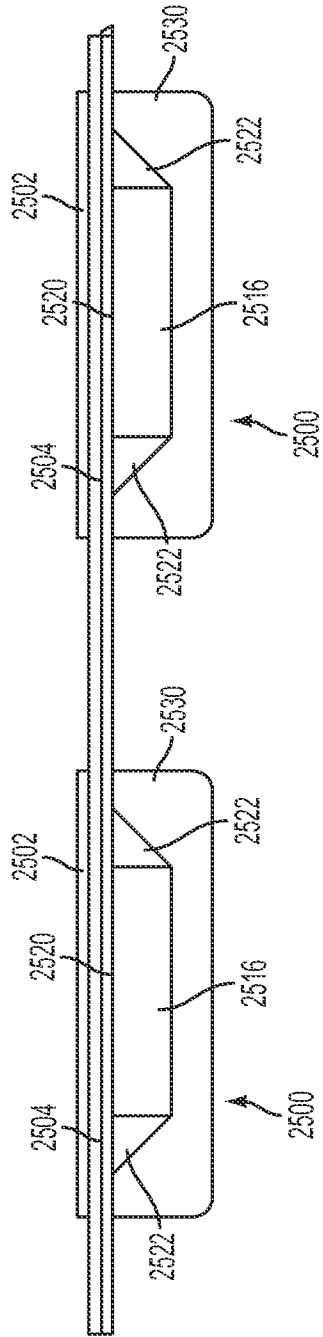

FIG. 25

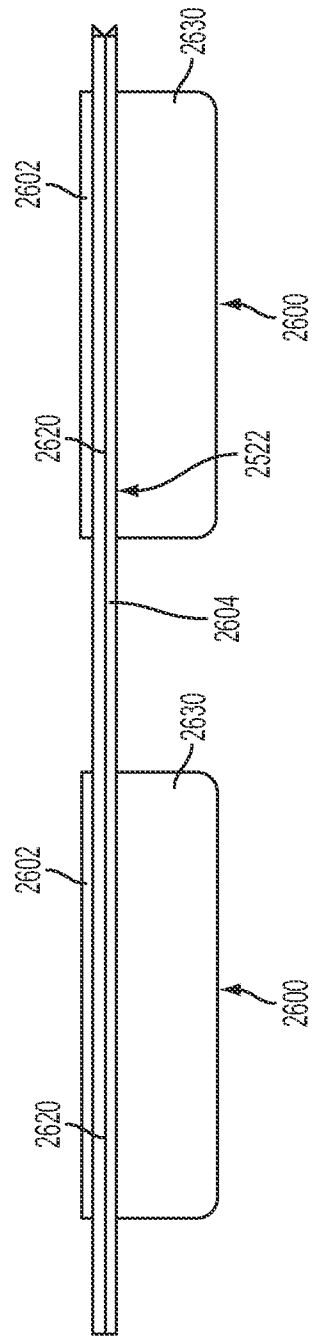

FIG. 26

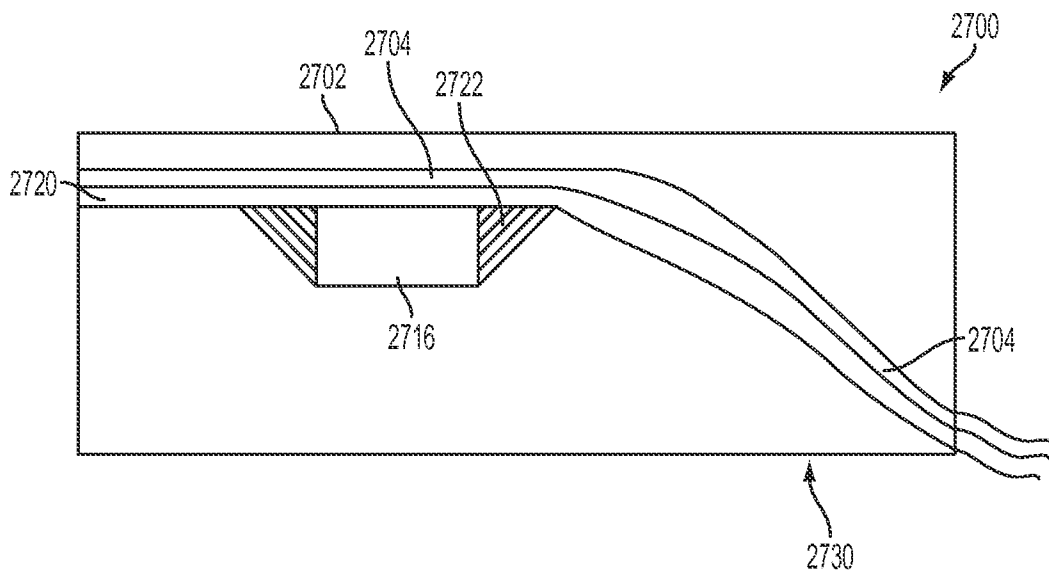

FIG. 27

TO FIG. 28-2

MEASUREMENT #1											
DATE	SAMPLE ID	SENSOR TYPE	RESIN	NANOPOWDER	DETAILS	SIZE	WT%	THICKNESS (um)	SIGNAL	NOISE	SNR
3/29/2013	1303291	RAPTOR 30B	3M CLEAR DP270	NONE				99	65.513	7.05	9.293
3/29/2013	1303292	RAPTOR 30B	3M CLEAR DP270	Al <sub>2</sub> O <sub>3</sub>		GRIT 1200	23	91.4	101.744	4.799	21.201
4/5/2013	1304051	RAPTOR 30B	3M CLEAR DP270	NONE					99.472	6.232	15.961
4/5/2013	1304052	RAPTOR 30B	3M CLEAR DP270	CNT + TiO <sub>2</sub> *	CNT 10 wt%		10.2		171.928	5.294	32.476
4/5/2013	1304053	RAPTOR 30B	3M CLEAR DP270	TiO <sub>2</sub>		100 nm	10.1		144.181	5.64	25.564
4/5/2013	1304054	RAPTOR 30B	3M CLEAR DP270	BaTiO <sub>3</sub>	CUBIC	100 nm	10		155.868	5.969	26.113
4/5/2013	1304055	RAPTOR 30B	3M CLEAR DP270	SrTiO <sub>3</sub>	CUBIC	100 nm GRIT 1200	10.1		121.102	6.016	20.130
4/5/2013	1304056	RAPTOR 30B	3M CLEAR DP270	Al <sub>2</sub> O <sub>3</sub>			10.1		92.034	6.081	15.135

FIG. 28-1

TO FIG. 28-3

		MEASUREMENT #2			MEASUREMENT #3			MEASUREMENT #4			MEASUREMENT #5			
DATE	SAMPLE ID	SENSOR TYPE	SIGNAL	NOISE	SNR	SIGNAL	NOISE	SNR	SIGNAL	NOISE	SNR	SIGNAL	NOISE	SNR
3/29/2013	1303291	RAPTOR 30B	75.947	7.017	10.823	75.189	7.036	10.686	70.767	7.033	10.062	67.724	7.036	9.625
3/29/2013	1303292	RAPTOR 30B	114.613	4.775	24.003	116.804	4.817	24.248	108.638	4.794	22.661	111.962	4.799	23.330
4/5/2013	1304051	RAPTOR 30B	93.643	6.252	14.978	95.992	6.25	15.359	93.141	6.22	14.974	94.072	6.253	15.044
4/5/2013	1304052	RAPTOR 30B	174.4	5.353	32.580	166.829	5.325	31.329	176.923	5.373	32.928	173.427	5.385	32.206
4/5/2013	1304053	RAPTOR 30B	144.213	5.872	24.559	150.942	5.854	25.784	148.157	5.835	25.391	149.891	5.834	25.693
4/5/2013	1304054	RAPTOR 30B	155.846	6.133	25.411	157.617	6.059	26.014	157.595	6.15	25.625	152.863	6.09	25.101
4/5/2013	1304055	RAPTOR 30B	119.429	6.137	19.460	119.427	6.099	19.581	113.081	6.126	18.459	121.352	6.092	19.920
4/5/2013	1304056	RAPTOR 30B	92.373	6.087	15.175	95.2	6.086	15.642	95.158	6.058	15.708	97.61	6.081	16.052

FROM  
FIG. 28-1

FIG. 28-2

DATE	SAMPLE ID	SENSOR TYPE	SIGNAL AVERAGE	NOISE AVERAGE	SNR AVERAGE
3/29/2013	1303291	RAPTOR 30B	71.028	7.034	10.098
3/29/2013	1303292	RAPTOR 30B	110.752	4.797	23.089
3/29/2013	1303292	RAPTOR 30B	95.264	6.241	15.263
4/5/2013	1304051	RAPTOR 30B	172.701	5.346	32.304
4/5/2013	1304052	RAPTOR 30B	147.477	5.807	25.398
4/5/2013	1304053	RAPTOR 30B	155.958	6.080	25.653
4/5/2013	1304054	RAPTOR 30B	118.878	6.094	19.510
4/5/2013	1304055	RAPTOR 30B	94.475	6.079	15.542

FROM FIG. 28-2

FIG. 28-3

**A. CLASSIFICATION OF SUBJECT MATTER****G06K 9/00(2006.01)i, H01L 23/28(2006.01)i, H01L 27/14(2006.01)i**

According to International Patent Classification (IPC) or to both national classification and IPC

**B. FIELDS SEARCHED**

Minimum documentation searched (classification system followed by classification symbols)

G06K 9/00; G01F 23/00; G01R 27/28; G09G 5/00; H01L 23/28; H01L 27/14

Documentation searched other than minimum documentation to the extent that such documents are included in the fields searched

Korean utility models and applications for utility models

Japanese utility models and applications for utility models

Electronic data base consulted during the international search (name of data base and, where practicable, search terms used)

eKOMPASS(KIPO internal) &amp; Keywords:biometric image sensor, fingerprint sensor, TX electrode, RX electrode, single substrate, differential amplifier, shift register, TFT

**C. DOCUMENTS CONSIDERED TO BE RELEVANT**

Category*	Citation of document, with indication, where appropriate, of the relevant passages	Relevant to claim No.
Y	US 2013-0009651 A1 (FRED G. BENKLEY, III) 10 January 2013 See paragraphs [0019], [0035], [0058]-[0064], [0087]-[0088], [0110]-[0111], [0125], [0142], [0177], [0181]; and figures 1, 8, 9a, 10, 12A-B, 15.	1-20
Y	US 2013-0177220 A1 (RICHARD ALEXANDER ERHART et al.) 11 July 2013 See paragraphs [0004], [0006], [0034], [0087]; and figure 3.	1-20
Y	US 2005-0031175 A1 (HIROYUKI HARA et al.) 10 February 2005 See paragraphs [0042]-[0045], [0084]; and figures 1, 9.	4-10, 14-20
A	US 2006-0114247 A1 (CHRIS J. BROWN) 01 June 2006 See paragraphs [0001], [0034], [0038], [0069], [0098]-[0100]; and figure 12.	1-20
A	US 2005-0005703 A1 (JUNICHI SAITO et al.) 13 January 2005 See paragraphs [0002], [0035]-[0037], [0048], [0052], [0057]; and figures 1, 6.	1-20

 Further documents are listed in the continuation of Box C. See patent family annex.

\* Special categories of cited documents:

"A" document defining the general state of the art which is not considered to be of particular relevance

"E" earlier application or patent but published on or after the international filing date

"L" document which may throw doubts on priority claim(s) or which is cited to establish the publication date of another citation or other special reason (as specified)

"O" document referring to an oral disclosure, use, exhibition or other means

"P" document published prior to the international filing date but later than the priority date claimed

"T" later document published after the international filing date or priority date and not in conflict with the application but cited to understand the principle or theory underlying the invention

"X" document of particular relevance; the claimed invention cannot be considered novel or cannot be considered to involve an inventive step when the document is taken alone

"Y" document of particular relevance; the claimed invention cannot be considered to involve an inventive step when the document is combined with one or more other such documents, such combination being obvious to a person skilled in the art

"&amp;" document member of the same patent family

Date of the actual completion of the international search

07 November 2014 (07.11.2014)

Date of mailing of the international search report

**07 November 2014 (07.11.2014)**

Name and mailing address of the ISA/KR

International Application Division  
Korean Intellectual Property Office  
189 Cheongsu-ro, Seo-gu, Daejeon Metropolitan City, 302-701,  
Republic of Korea

Facsimile No. +82-42-472-7140

Authorized officer

KANG, Sung Chul

Telephone No. +82-42-481-8405



**INTERNATIONAL SEARCH REPORT**

Information on patent family members

International application No.

**PCT/US2014/048049**

Patent document cited in search report	Publication date	Patent family member(s)	Publication date		
US 2013-0009651 A1	10/01/2013	CN 102893248 A	23/01/2013		
		CN 102906761 A	30/01/2013		
		EP 2524339 A1	21/11/2012		
		JP 2013-517571 A	16/05/2013		
		KR 10-2012-0116983 A	23/10/2012		
		KR 10-2012-0116984 A	23/10/2012		
		TW 2011-31483 A	16/09/2011		
		US 2011-0175703 A1	21/07/2011		
		US 2011-0176037 A1	21/07/2011		
		US 2012-0134549 A1	31/05/2012		
		US 8421890 B2	16/04/2013		
		US 8791792 B2	29/07/2014		
		WO 2011-088248 A1	21/07/2011		
		WO 2011-088252 A1	21/07/2011		
		US 2013-0177220 A1	11/07/2013	DE 10 2012 025255 A1	27/06/2013
				GB 2012-23233 D0	06/02/2013
GB 2499497 A	21/08/2013				
KR 10-2013-0073857 A	03/07/2013				
TW 2013-37782 A	16/09/2013				
US 2005-0031175 A1	10/02/2005	CN 1576774 A	09/02/2005		
		CN 1576774 C0	25/10/2006		
		JP 2005-049193 A	24/02/2005		
		JP 3741282 B2	01/02/2006		
		KR 10-0658997 B1	21/12/2006		
		TW 1250464 B	01/03/2006		
US 2006-0114247 A1	01/06/2006	CN 1773442 A	17/05/2006		
		CN 1773442 C0	16/04/2008		
		GB 0424688 D0	08/12/2004		
		GB 2419950 A	10/05/2006		
		JP 2006-184273 A	13/07/2006		
		JP 4628250 B2	09/02/2011		
		KR 10-0740394 B1	16/07/2007		
		KR 10-2006-0052547 A	19/05/2006		
		US 2005-0005703 A1	13/01/2005	CN 1576799 A	09/02/2005
EP 1496467 A2	12/01/2005				
EP 1496467 A3	09/08/2006				
JP 2005-030901 A	03/02/2005				
KR 10-2005-0007131 A	17/01/2005				